

Materials and Procedures for Repair of Potholes in Asphalt-Surfaced Pavements

Manual of Practice



Federal Highway Administration
U.S. Department of Transportation



Strategic Highway Research Program
National Research Council

FOREWORD

This manual (FHWA-RD-99-168) is an update of the Strategic Highway Research Program (SHRP) manual of practice (SHRP H-349) on the repair of potholes in asphalt-surfaced pavements. The Federal Highway Administration's (FHWA) Long Term Pavement Performance (LTPP) program conducted 5 years of additional research on pothole repair after the conclusion of SHRP. This research validated the repair techniques contained in the original SHRP manual.

This manual presents updated guidelines and recommendations to assist highway maintenance agencies and other related organizations in planning, constructing, and monitoring the performance of pothole repairs in asphalt-surfaced pavements. Included in the manual are discussions pertaining to the decision to patch potholes, the types of patching materials and techniques that should be used, how each individual step in a patching operation should be performed, and how the performance and cost-effectiveness of pothole repairs can be evaluated. This report will be of interest and benefit to various levels of agency maintenance personnel, from crew supervisors to the chief maintenance engineer.

NOTICE

This document is disseminated under the sponsorship of the Department of Transportation in the interest of information exchange. The United States Government assumes no liability for its contents or use thereof. This report does not constitute a standard, specification, or regulation.

The United States Government does not endorse products or manufacturers. Trade and manufacturers' names appear in this report only because they are considered essential to the object of the document.

1. Report No. FHWA-RD-99-168	2. Government Accession No.	3. Recipient's Catalog No.	
4. Title and Subtitle MATERIALS AND PROCEDURES FOR REPAIR OF POTHOLES IN ASPHALT-SURFACED PAVEMENTS -- MANUAL OF PRACTICE		5. Report Date	
		6. Performing Organization Code	
7. Author(s) T.P. Wilson and A.R. Romine		8. Performing Organization Report No.	
9. Performing Organization Name and Address ERES Consultants A Division of Applied Research Associates, Inc. 505 W. University Avenue Champaign, IL 61820-3915		10. Work Unit No. (TRAIS)	
		11. Contract or Grant No. DTFH61-93-C-00051	
12. Sponsoring Agency Name and Address Office of Infrastructure Research and Development Federal Highway Administration 6300 Georgetown Pike McLean, Virginia 22101-2296		13. Type of Report and Period Covered Updated Manual of Practice October 1993 - June 1999	
		14. Sponsoring Agency Code	
15. Supplementary Notes FHWA Contracting Officer's Technical Representative (COTR): Shahed Rowshan, HRDI Project Consultant: Charlie Smyth			
16. Abstract The Strategic Highway Research Program (SHRP) H-106 maintenance experiment and the Federal Highway Administration (FHWA) Long-Term Monitoring (LTM) of Pavement Maintenance Materials Test Sites project studied the repair of potholes in asphalt-surfaced pavements. Many different repair materials and methods were investigated between 1991 and 1996 through test sites installed at eight locations in the United States and Canada. The findings of these combined studies have been merged with standard highway agency procedures to provide the most useful and up-to-date information on the practice of repairing potholes. This Manual of Practice is an updated version of the 1993 SHRP Pothole Repair Manual. It contains the latest information pertaining to the types and performance characteristics of repair materials and methods, as well as, the proper ways of planning, designing, constructing, and monitoring the performance of pothole repair projects. It also details how the cost-effectiveness of pothole patch types can be determined and it provides an updated partial listing of material and equipment manufacturers. This Manual is intended for field and office personnel within highway maintenance agencies and contracted maintenance firms. It contains valuable information for supervisors and foremen in charge of individual patching operations, engineers in charge of planning and overseeing many patching projects, and managers in charge of establishing pothole repair policies and standards.			
17. Key Words Asphalt concrete, pavement, pavement maintenance, potholes, patching, cold-mix, spray-injection, performance, effectiveness, cost-effectiveness		18. Distribution Statement No restrictions. This document is available to the public through the National Technical Information Service, Springfield, Virginia 22161.	
19. Security Classif. (of this report) Unclassified	20. Security Classif. (of this page) Unclassified	21. No of Pages 85	22. Price

Preface

This manual is intended for use by highway maintenance agencies and contracted maintenance firms in the field and in the office. It is a compendium of good practices for asphalt concrete (AC) pothole repair, stemming from the Strategic Highway Research Program (SHRP) pavement maintenance studies and a follow-up study sponsored by the Federal Highway Administration (FHWA).

In SHRP Project H-105, Innovative Materials and Equipment for Pavement Surface Repair, the researchers conducted a massive literature review and a nationwide survey of highway agencies to identify potentially cost-effective pavement repair and treatment options (Smith et al., 1991). The information and findings from that study were then used in the subsequent field experiments conducted under SHRP Project H-106, Innovative Materials Development and Testing.

In Project H-106, many different test sections were installed and evaluated to determine the cost-effectiveness of maintenance materials and procedures. Test sections were installed at 22 sites throughout the United States and Canada between March 1991 and February 1992, under the supervision of SHRP representatives. The researchers collected installation and productivity information at each site and periodically evaluated the experimental repairs and treatments through the end of 1992. The first version of this manual was prepared in October 1993 and was based on this work effort.

Following the conclusion of SHRP H-106 in 1993, the FHWA sponsored a study to continue monitoring the performance of the experimental repairs and treatments, beginning in October 1993. Under the Long-Term Monitoring (LTM) of Pavement Maintenance Materials Test Sites project, the repairs and treatments were evaluated annually through the end of 1997.

Pertinent long-term performance and cost-effectiveness information generated by the continued monitoring of the experimental pothole repairs has been included in this revised manual.

For the reader's convenience, potentially unfamiliar terms are italicized at their first occurrence in the manual and are defined in a glossary. Readers who want more information on topics included in this manual should refer to the reference list provided at the back. The final report for the H-106/LTM AC pothole repair study may be of particular interest to many readers (Wilson, 1998). It details the installation procedures, laboratory testing of the materials, and field performance of each of the repair types investigated.

Acknowledgments

The research described herein was supported by the Strategic Highway Research Program (SHRP) and the Federal Highway Administration (FHWA). SHRP was a unit of the National Research Council that was authorized by Section 128 of the Surface Transportation and Uniform Relocation Assistance Act of 1987.

Special thanks are due the project management teams at SHRP and the FHWA, and to the following highway agencies:

- Illinois Department of Transportation.
- Vermont Agency of Transportation.
- Ministry of Transportation of Ontario.
- City of Draper, Utah.
- California Department of Transportation.
- Oregon Department of Transportation.
- Texas Department of Transportation.
- New Mexico State Highway and Transportation Department.

The contributions of the following individuals are also acknowledged: Michael Darter, Samuel Carpenter, and David Peshkin.

Contents

1.0	Introduction	1
1.1	Scope of Manual	1
1.2	Pothole Repair	2
2.0	Need for Pothole Repair	3
3.0	Planning and Design	5
3.1	Materials	5
3.1.1	Compatibility testing	6
3.1.2	Acceptance testing	7
3.2	Repair Techniques	7
3.2.1	Throw-and-roll	8
3.2.2	Semi-permanent	11
3.2.3	Spray injection	11
3.2.4	Edge seal	16
3.3	Patching Costs	19
3.3.1	Materials	19
3.3.2	Labor	19
3.3.3	Equipment	20
3.4	Overall Cost-Effectiveness	21
3.4.1	Cost-effectiveness worksheet	21
3.4.2	Determination of cost-effectiveness inputs	26
4.0	Construction	27
4.1	Traffic Control	27
4.2	Safety	28
4.3	Winter Patching	28
4.3.1	Materials	29
4.3.2	Selecting a procedure	29
4.3.3	Other considerations	29

4.4	Spring Patching	30
4.4.1	Materials	30
4.4.2	Selecting a procedure	31
4.4.3	Other considerations	31
5.0	Evaluating Repair Performance	33
5.1	Data Required	33
5.2	Calculations	33
5.2.1	Patch survival rating	33
5.2.2	Expected average repair life	37
Appendix A	Material Testing	39
A.1	Compatibility Testing Procedure	40
A.1.1	Coating test	41
A.1.2	Stripping test	43
A.1.3	Drainage test	45
A.2	Acceptance Testing Procedure	47
A.2.1	Workability test	47
A.2.2	Cohesion test	49
Appendix B	Sample Cost-Effectiveness Calculations	53
Appendix C	Partial List of Material and Equipment	
	Sources	67
C.1	Patching Materials	68
C.2	Patching Equipment	69
C.3	Patching Services	70
	Glossary	71
	References	73

List of Figures

Figure 1.	Throw-and-roll procedure—material placement	9
Figure 2.	Throw-and-roll procedure—compaction of patch	10
Figure 3.	Semi-permanent procedure—straightening edges using hand-held pavement saw	12
Figure 4.	Semi-permanent procedure—straightening edges using cold-milling machine	13
Figure 5.	Semi-permanent procedure—compaction using vibratory-plate compactor	14
Figure 6.	Semi-permanent procedure—single-drum vibratory roller used for compaction	15
Figure 7.	Spray-injection device—truck and trailer unit	17
Figure 8.	Spray-injection device—self-contained unit	18
Figure 9.	Worksheet for patching costs	22
Figure 10.	Example of patch survival curves	35
Figure A-1.	Workability testing box and penetrometer adapter	48
Figure A-2.	Rolling sieve cohesion test	50

Figure B-1.	Cost worksheet for example 1	56
Figure B-2.	Cost worksheet for example 2	58
Figure B-3.	Cost worksheet for example 3	60
Figure B-4.	Cost worksheet for example 4	62
Figure B-5.	Cost worksheet for example 5	64

List of Tables

Table 1.	Sample patch performance data	34
Table 2.	Worksheet for calculating patch survival rate	36
Table 3.	Worksheet for calculating average repair life	37
Table A-1.	Data table for coating test	42
Table A-2.	Data table for stripping test	44
Table A-3.	Data table for drainage test	46

1.0 Introduction

As asphalt pavements age and deteriorate, the need for corrective measures to restore safety and rideability increases. Funding for rehabilitation and overlay of these pavements is not likely to keep up with the demand, requiring more agencies to use the most cost-effective methods when patching distressed areas. The patches will also be expected to survive longer and carry more traffic.

1.1 Scope of Manual

This manual describes materials and procedures for the repair of *potholes** in asphalt-surfaced pavements. The materials and procedures discussed are for cold-mix stockpiled materials and for *spray-injection* patching devices. The information in this manual has been obtained through reviews of literature and current practices and through the results of various pothole repair studies, most notably the recently completed Strategic Highway Research Program (SHRP) Project H-106. Under Project H-106, the field performance of various cold-mix patching materials and procedures, as well as spray-injection patches, were investigated (Wilson, 1998). The use of hot-mix asphalt concrete (AC), although recognized as a preferred alternative for patching operations, is not covered in this manual.

The patching operations described in this manual can be performed in any weather. With the exception of the spray-injection procedure, they require the use of cold-mix patching materials. The spray-injection procedure requires a device that

* Italicized words are defined in the glossary.

can place virgin aggregate and heated emulsion into a pothole simultaneously; even so, this procedure can be carried out in most weather conditions.

1.2 Pothole Repair

Potholes occur on asphalt-surfaced pavements subjected to a broad spectrum of traffic levels, from two-lane rural routes to multi-lane interstate highways. Any agency responsible for asphalt-surfaced pavements (either full-depth or composite) eventually performs *pothole patching*. Pothole patching is generally performed either as an emergency repair under harsh conditions, or as routine maintenance scheduled for warmer and drier periods. Pothole patching can be performed during weather conditions ranging from clear spring days to harsh winter storms, with temperatures anywhere from 38EC to -18EC.

Even though the moisture and traffic conditions may vary, the materials and methods for placing quality repairs are fairly similar. This manual describes patching techniques that have been used successfully under actual field conditions across the United States and Canada.

2.0 Need for Pothole Repair

The decision to patch potholes is influenced by many factors:

- The level of traffic.
- The time until scheduled rehabilitation or overlay.
- The availability of personnel, equipment, and materials.
- The tolerance of the traveling public.

In most cases, the public likes all potholes to be repaired promptly and forms a negative opinion of the highway agency when this fails to happen.

Potholes are generally caused by moisture, freeze-thaw action, traffic, poor underlying support, or some combination of these factors. Pothole repair is necessary in those situations where potholes compromise safety and pavement rideability.

Pothole repair operations can usually be divided into two distinct periods. The first period is winter repairs, when temperatures are low, base material is frozen, and additional moisture and freeze-thaw cycles are expected before the spring thaw. The second period is spring repairs, when base material is wet and soft, and few additional freeze-thaw cycles are expected.

Regardless of the climatic conditions, the potential safety and rideability problems that could result from the unrepaired distress must be considered when deciding whether a pothole should be patched. A highway agency must repair potentially hazardous potholes as soon as it becomes aware of them.

3.0 Planning and Design

The two main elements of quality pothole patching are material selection and repair procedures. For every combination of these two factors, the cost-effectiveness of the overall patching operation will be affected by material, labor, and equipment costs. The combinations of materials and procedures that will produce optimum cost-effectiveness vary from agency to agency. The following sections discuss each of these items.

3.1 Materials

Most agencies have three types of cold mixes available to them. The first of these is cold mix produced by a local asphalt plant, using the available aggregate and binder, usually without an opportunity to consider compatibility or expected performance.

The second type is cold mix produced according to specifications set by the agency that will use the mix. The specifications normally include the acceptable types of aggregate and asphalt, as well as acceptance criteria for the agency to purchase the material. The aggregate and asphalt are usually tested for compatibility before specifying acceptable sources. The use of spray-injection devices by agency employees would fall into this category, since the agency must check the asphalt-aggregate compatibility before placing patches.

The third type is proprietary cold mix. A local asphalt plant generally produces this material using specially formulated binders. These binders are produced by companies that test the local aggregate, design the mixes, and monitor production to ensure the quality of the product. These materials (like other cold mixes) can be produced in bulk and stockpiled, or they can be packaged into buckets or bags to make the material easier to

handle in the field. Spray-injection patching performed by a contractor would fall into this third category, since the aggregate and binder are supplied by and should be tested by a patching contractor.

For each of these materials, an agency must address different concerns when verifying the quality of materials used for patching. When using cold mixes produced according to agency specifications, the compatibility of the binder and aggregate must be checked. When using proprietary materials that are already mixed, some acceptance testing must be done before purchasing the material. Acceptance testing of spray-injection materials is more difficult than for a stockpiled cold mix due to the nature of the finished product. Examples of both compatibility and acceptance testing procedures are provided below.

3.1.1 Compatibility testing

The first step in producing a quality cold-mix material is to test the compatibility of the binder and aggregate. Although the majority of asphalt-aggregate combinations will produce satisfactory results, some combinations produce cold mixes that do not perform well. Being able to identify potential mix problems prior to large-scale production can be very beneficial.

In addition to determining compatibility, an agency must also determine target asphalt contents. Appendix A summarizes a testing plan for material compatibility and for estimating the optimum asphalt content. This testing plan is recommended when an agency is considering using a previously untried combination of asphalt and aggregate.

Most agencies use cold mixes consisting of asphalt-aggregate combinations that have been used successfully. The following section describes a testing plan to ensure the quality of the cold-mix material before use under actual roadway conditions.

3.1.2 Acceptance testing

When a previously used cold-mix or proprietary material is being considered for use, acceptance testing is recommended to ensure the quality of the current batches. The acceptance test procedure is presented in appendix A. Although the acceptance procedure does not guarantee a successful patching material, it is designed to identify materials likely to perform poorly in the field.

3.2 Repair Techniques

Many maintenance agencies use the *throw-and-go* method for repairing potholes. Although not considered the best way to patch potholes, it is the most commonly used method because of its high rate of production. The procedure described in this manual is more accurately termed *throw-and-roll*, and it should be considered a superior alternative to the traditional throw-and-go method.

An installation technique used by many agencies is the *semi-permanent* repair procedure. This procedure represents an increased level of effort for patching potholes. This increased effort increases the performance of the patches by improving the underlying and surrounding support provided for the patches. It also raises the cost of the patching operation.

Agencies also use spray-injection devices for repairing potholes. This technique has higher equipment costs than the other

procedures, but it also has a high rate of productivity and lower material costs.

Another method used by some agencies is the *edge seal* method. This method requires a second pass through the repair area, but can improve patch performance in older pavements with a lot of cracking.

3.2.1 Throw-and-roll

The throw-and-roll method consists of the following steps:

1. Place the material into a pothole (which may or may not be filled with water or debris), as shown in figure 1.
2. Compact the patch using truck tires, as shown in figure 2.
3. Verify that the compacted patch has some crown between 3 and 6 mm).
4. Move on to the next pothole.
5. Open the repaired section to traffic as soon as maintenance workers and equipment are cleared from the area.

One difference between this method and the traditional throw-and-go method is that some effort is made to compact the patches. Compaction provides a tighter patch for traffic than simply leaving loose material. The extra time to compact the patches (generally 1 to 2 additional minutes per patch) will not significantly affect productivity. This is especially true if the areas to be patched are separated by long distances and most of the time is spent traveling between potholes.



Figure 1. Throw-and-roll procedure—material placement.



Figure 2. Throw-and-roll procedure—compaction of patch.

3.2.2 Semi-permanent

The semi-permanent repair method is considered one of the best for repairing potholes, short of full-depth removal and replacement. This procedure includes the following steps:

1. Remove water and debris from the pothole.
2. Square-up the sides of the patch area until vertical sides exist in reasonably sound pavement, as shown in figures 3 and 4.
3. Place the mix.
4. Compact with a device smaller than the patch area. (Single-drum vibratory rollers and vibratory plate compactors work best.) [See figures 5 and 6.]
5. Open the repaired section to traffic as soon as maintenance workers and equipment are cleared from the area.

This repair procedure provides a sound area for patches to be compacted against and results in very tightly compacted patches. However, it requires more workers and equipment and has a lower productivity rate than either the throw-and-roll or the spray-injection procedure.

3.2.3 Spray injection

The spray-injection procedure consists of the following steps:

1. Blow water and debris from the pothole.
2. Spray a tack coat of binder on the sides and bottom of the pothole.
3. Blow asphalt and aggregate into the pothole.
4. Cover the patched area with a layer of aggregate.



Figure 3. Semi-permanent procedure—straightening edges using hand-held pavement saw.



Figure 4. Semi-permanent procedure—straightening edges using cold-milling machine.



Figure 5. Semi-permanent procedure—compaction using vibratory-plate compactor.



Figure 6. Semi-permanent procedure—single-drum vibratory roller used for compaction.

5. Open the repaired section to traffic as soon as maintenance workers and equipment are cleared from area.

This procedure requires no compaction after the cover aggregate has been placed. Figures 7 and 8 illustrate the two main types of spray-injection devices available. The first (figure 7) is a trailer unit towed behind a truck carrying the aggregate. The second (figure 8) is a unit with aggregate, heated binder tank, and delivery systems all contained in a single vehicle.

3.2.4 Edge seal

The edge seal method consists of the following steps:

1. Place the material into a pothole (which may or may not be filled with water or debris). [See figure 1.]
2. Compact the patch using truck tires. [See figure 2.]
3. Verify that the compacted patch has some crown (between 3 and 6 mm).
4. Move on to the next pothole.
5. Once the repaired section has dried, place a ribbon of asphaltic tack material on top of the patch edge (tack material should be placed on both patch and pavement surfaces).
6. Place a layer of sand on the tack material to prevent tracking by vehicle tires.
7. Open the repaired section to traffic as soon as maintenance workers and equipment are cleared from the area.

This procedure may require a second visit to the repaired section by the crew to allow water to dry before placing the tack. Although this does reduce the productivity of the procedure, the placement of the tack material prevents water



Figure 7. Spray-injection device—truck and trailer unit.



Figure 8. Spray-injection device—self-contained unit.

from getting through the edge of the patch and can glue together pieces of the surrounding pavement, improving support for the patch.

3.3 Patching Costs

The three main costs for pothole patching are material, labor, and equipment. The following sections discuss the costs of these aspects of the patching operation. There may also be some user-delay costs associated with pothole patching operations, as well as associated lane-closure time.

3.3.1 Materials

The cost most commonly associated with pothole patching is the cost of materials. This is usually one of the least significant contributors to the overall cost of a patching operation. However, the material used for patching does impact the cost of the overall operation when there are differences in performance. More expensive materials that are placed with less effort and last longer can reduce the cost of the initial patching effort, as well as the amount of repatching needed. This reduces the labor and equipment costs for the overall operation.

3.3.2 Labor

For the throw-and-roll technique, the labor cost can be as little as two workers who do the actual patching, plus traffic control. One of the two workers shovels the material from the truck into the pothole, and the other drives the truck over the section to compact the patch. In some instances, the driver of the vehicle

is able to shovel material when patching large areas. This generally improves the productivity of the overall operation.

The edge seal procedure requires the same two workers and traffic control as the throw-and-roll procedure, but requires an extra pass to place the tack and sand materials.

The semi-permanent patching operation has proven to be the most efficient when four workers are used, along with the appropriate traffic control. Two workers clear out debris and square-up the edges, while the other two follow behind, placing material and compacting the patches. This procedure can be accomplished using more or fewer workers, but the experience of many agencies has found four workers to be optimum.

The cost of traffic control can be handled in several different ways, depending on the site of the patching operation and the needs of the particular agency. Labor costs for traffic control should be included when necessary.

The single-unit spray-injection device requires a single operator. Two operators are recommended when using the trailer-unit equipment (one to operate the vehicle and one to place the material). In both cases, traffic control is required.

3.3.3 Equipment

For the throw-and-roll, edge seal, and semi-permanent methods, shovels, rakes, or other handtools are needed for placing the material. For the throw-and-roll and edge seal methods, the only major equipment costs are for the truck carrying the material and the traffic control vehicles and signs.

For the semi-permanent repair method, the necessary equipment varies from agency to agency. A basic list includes the following:

- Material truck (with handtools).
- Equipment truck.
- Compaction device (vibratory plate and single-drum vibratory roller are generally both the most inexpensive and the most maneuverable).
- Air compressor.
- Edge-straightening device (jackhammer, pavement saw, cold-milling machine).
- Traffic control vehicles and signs.

The only equipment needed for spray injection is the spray-injection device and the traffic control trucks and signs.

3.4 Overall Cost-Effectiveness

To evaluate its current patching operation, an agency must calculate the cost-effectiveness of the overall operation. Figure 9 shows a worksheet that can be used to calculate the cost of a patching operation. This form can be used either for a current operation or for a proposed patching operation, using different materials or procedures.

3.4.1 Cost-effectiveness worksheet

The worksheet shown in figure 9 requires the user to enter information for each material–procedure combination to be evaluated. Explanations of the inputs are given below.

MATERIAL COSTS			
Material Purchase Cost	_____	\$/metric ton	(A)
Material Shipping Cost	_____	\$/metric ton	(B)
Anticipated Material Needs	_____	metric tons	(C)
LABOR COSTS			
Number in Patching Crew	_____		(D)
Average Daily Wage per Person	_____	\$/day	(E)
Number in Traffic Control Crew	_____		(F)
Average Daily Wage per Person	_____	\$/day	(G)
Supervisor Daily Wage	_____	\$/day	(H)
EQUIPMENT COSTS			
Material Truck	_____	\$/day	(I)
Traffic Control Truck and Signs	_____	\$/day	(J)
Preparation Equipment (e.g., compressor, jackhammer, pavement saw)	_____	\$/day	(K)
Compaction Equipment (e.g., vibratory plate, single-drum)	_____	\$/day	(L)
Extra Equipment Truck	_____	\$/day	(M)
Specialty Equipment (e.g., spray-injection device)	_____	\$/day	(N)
USER COSTS			
User Delay Costs	_____	\$/day	(O)

Figure 9. Worksheet for patching costs.

Total Material Cost [(A+B)×C]	_____	\$	(P)
Total Daily Labor Cost [(D×E)+(F×G)+H]	_____	\$/day	(Q)
Total Equipment Cost (I+J+K+L+M+N)	_____	\$/day	(R)
Average Daily Productivity	_____	metric tons/day(S)	
Estimated Days for Initial Patching Operation (C÷S)	_____	days	(T)
Total User, Labor, and Equipment Cost [(O+Q+R)×T]	_____	\$	(U)
Total Labor and Equipment Cost [(Q+R)×T]	_____	\$	(V)
Total Patching Operation Cost With User Costs (P+U)	_____	\$	(W)
Total Patching Operation Cost Without User Costs (P+V)	_____	\$	(X)
Expected Patch Survival	_____	months	(Y)
Patching Analysis Period	_____	months	(Z)
Effective Patching Operation Cost With User Costs [W×(Z÷Y)]	_____	\$	(AA)
Effective Patching Operation Cost Without User Costs [X×(Z÷Y)]	_____	\$	(BB)
Cost per Original Pothole Volume With User Costs [AA×(2.0÷C)]	_____	\$/m ³	(CC)
Cost per Original Pothole Volume Without User Costs [BB×(2.0÷C)]	_____	\$/m ³	(DD)

Figure 9. Worksheet for patching costs (continued).

- (A) **Material Purchase Cost**—The cost of purchasing or producing the material, not including shipping costs. The amount entered should be in dollars per metric ton.
- (B) **Material Shipping Cost**—The cost of shipping the material from the site of production to the location of the stockpile. The amount entered should be in dollars per metric ton.
- (C) **Anticipated Material Needs**—The amount of patching material needed for 1 year of pothole patching. The amount entered should be in metric tons.
- (D) **Number in Patching Crew**—The number of workers who will be performing the patching operation. This number does not include traffic control personnel.
- (E) **Average Daily Wage per Person**—The average wages paid to the members of the patching crew. Multiplying this figure by (D) results in the total labor costs for the patching crew. The amount entered should be in dollars per day.
- (F) **Number in Traffic Control Crew**—The number of workers required to set up and maintain the traffic control operation. When the patching crew sets up traffic control before patching, the number of traffic control workers is zero, so that workers are not counted twice.
- (G) **Average Daily Wage per Person**—The average wages paid to the members of the traffic control crew. Multiplying this figure by (F) results in the total labor costs for the traffic control crew. The amount entered should be in dollars per day.
- (H) **Supervisor Daily Wage**—The wage paid to a supervisor or foreman who oversees the patching operation. If the supervisor is not exclusively involved in patching operations for the entire time, a fraction of the daily wage should be entered to estimate the time spent with the patching operation. The amount entered should be in dollars per day.

- (I) **Material Truck**—The operating charges associated with the truck carrying the material. Only trucks transporting patching material should be included. The amount entered should be in dollars per day.
- (J) **Traffic Control Truck and Signs**—The cost associated with all traffic control trucks and devices, including arrow boards, attenuators, and so on. If vehicles are used both to set up traffic control and for other activities during the day, a fraction of the daily cost should be used to estimate the time spent establishing traffic control. The amount entered should be in dollars per day.
- (K) **Preparation Equipment**—The cost associated with any equipment used to prepare the pothole before placing the patching material. If the throw-and-roll or spray-injection methods are used, this value is zero. The amount entered should be in dollars per day.
- (L) **Compaction Equipment**—The cost associated with any extra equipment used to compact the patches. If the material truck is used for compaction, this value is zero. The amount entered should be in dollars per day.
- (M) **Extra Equipment Truck**—The cost associated with any extra truck used to transport preparation or compaction equipment to the site. The amount entered should be in dollars per day.
- (N) **Specialty Equipment**—The cost associated with any special equipment used for the patching operation (e.g., spray-injection devices). The amount entered should be in dollars per day.
- (O) **User Delay Costs**—The cost to the users of the roadway of the delay caused by the patching operation. The amount should be entered in dollars per day.
- (S) **Average Daily Productivity**—The rate at which the patching crew can place the patching material. This amount should be for the crew size specified above. The amount entered should be in metric tons per day.

- (Y) **Expected Patch Survival**—An estimate of the average life of patches to be placed. The value should be entered in months.
- (Z) **Patching Analysis Period**—The duration for which the cost-effectiveness analysis is being calculated. This is generally a period of between 3 and 5 years. The value should be entered in months.

3.4.2 Determination of cost-effectiveness inputs

A supervisor or foreman familiar with the crew and the available equipment can provide most of the information required to complete the cost-effectiveness worksheet.

The most difficult value to obtain accurately is the "expected patch survival." The pavement condition, material quality, climatic influence, crew ability, and past repair performance will all factor into this value. Chapter 5 presents one method for estimating the expected patch survival.

Appendix B contains examples of the cost-effectiveness calculation for several different types of patching operations.

4.0 Construction

Pothole-patching operations are usually performed when potholes have developed at various locations throughout a maintenance area. Most patching operations simply try to repair the distress and restore rideability as quickly as possible. This chapter contains recommendations for improving the overall quality of the patches.

These recommendations are divided into winter and spring patching alternatives and include preparation, placement, and compaction alternatives. Suggestions for traffic control and safety are also included. The person most familiar with local conditions and the requirements for a safe traffic control situation should always make the final decisions concerning the safety of both the patching crew and the passing vehicles.

4.1 Traffic Control

Whenever any pothole patching operation is performed, adequate traffic control must be provided. This ensures a safe working environment for the maintenance crew and safe travel lanes for vehicles. Traffic control operations should disturb the flow of traffic as little as possible.

Although the actual traffic control requirements for each agency will vary, **every maintenance agency is responsible for providing a work area that is as safe as possible for both workers and drivers and for ensuring that all necessary steps are always taken to maintain safety.**

4.2 Safety

Safety concerns are not limited to traffic control. There are also safety concerns when using the repair materials and equipment. Material safety data sheets (MSDS) are available for the majority of cold-mix materials. Special recommendations for handling and storing of all cold-mix materials should be followed closely.

Operators of jackhammers and other compressed-air equipment should exercise caution with the equipment, as should operators of spray-injection devices. In particular, the aggregate from spray-injection devices can rebound with great force, and eye protection is highly recommended. Vehicle operators must exercise caution when moving in reverse, especially if other workers are in the area.

Everyone on the job should know where the potential hazards are located and should take care to avoid any possibly dangerous situations.

4.3 Winter Patching

Winter patching operations generally take place during periods of snow melt, when maintenance crews do not have to plow or apply abrasives or salt. Warmer weather not only provides time to patch, it also creates conditions conducive to the development of potholes. Warmer temperatures cause thawing and softening of frozen base materials, reducing underlying pavement support.

More stress is placed on the patching materials as they cycle between very cold and warm conditions because winter patching occurs while more winter conditions are expected.

4.3.1 Materials

Aggregates used for winter patching conditions should be high-quality, crushed aggregate with few fines. Binders should be emulsified asphalts with at least an anti-stripping additive. The mixture should be workable at low temperatures to allow both easier handling by the workers and easier compaction in the pothole. It is highly likely that water will be in the pothole, so an anti-stripping additive is crucial.

4.3.2 Selecting a procedure

Patching potholes under winter conditions does not usually allow time for using the semi-permanent procedure. Increasing the time required to patch the potholes decreases the productivity of the operation and increases the amount of time that the crew is exposed to traffic.

With a high-quality material, the throw-and-roll procedure provides a cost-effective means of patching under winter conditions. It is extremely important that a high-quality material be used and that it be compacted by the truck. Leaving the patch to be compacted by traffic will result in premature patch failures.

4.3.3 Other considerations

Patches placed under winter conditions have a shorter life expectancy than patches placed in the spring. This document presents information that can extend the life of winter patches from several days to several months. The goal of winter patching is to restore rideability and safety as quickly as possible (not to repair the distress permanently).

4.4 Spring Patching

Spring patching differs from winter operations in that the climatic conditions will not stress the patches to the same degree. Because freeze-thaw cycling is finished, most of the conditions that soften the underlying support will have passed. Better climatic conditions increase the life expectancy for patches placed in the spring.

4.4.1 Materials

The choice of materials for spring patching should be based on a calculation of their cost-effectiveness. However, even when the cost-effectiveness calculation may indicate the superiority of one material over another, the experience of the local maintenance crew should be considered.

Any material acceptable for winter patching is generally acceptable for spring patching. However, the effects of having been stockpiled over the winter and the differences in workability over wide temperature ranges should be considered. Materials that are workable at very low temperatures tend to be very sticky and hard to use at higher temperatures.

High-quality crushed aggregate with few fines and an emulsified asphalt should be used for spring patching. Anti-stripping additives are still advisable. The mixtures can be slower setting than winter materials, since higher temperatures allow more rapid evaporation.

4.4.2 Selecting a procedure

Spring patching can be done by spray injection, or by the throw-and-roll, semi-permanent, or edge seal procedures. Cost-effectiveness and the availability of equipment and workers should be the most important criteria. Because the semi-permanent procedure requires more equipment and workers, and the edge seal procedure requires a second trip to the repair area, those procedures may be impractical in some instances.

The throw-and-roll procedure should be considered a viable alternative for placing spring patches. Results from a recent study indicate that patches placed with this method can provide satisfactory results when high-quality materials are used (Smith et al., 1991).

4.4.3 Other considerations

Patches placed during the spring are expected to last longer than patches placed under winter conditions. Observations in a recent field test indicated that patches in place after the initial setting period (2 to 4 weeks) were likely to remain in place until the surrounding pavement begins to deteriorate. The goal of spring patching operations should be to place patches that last as long as the surrounding pavement. Patches surviving as long as the surrounding pavement reduce the cost of the overall operation by reducing the amount of labor, equipment, and material needed.

5.0 Evaluating Repair Performance

When two or more patch types have been installed for the purpose of comparison, some method is needed to rank the patch types from best to worst. Two methods for calculating a performance factor are described here.

5.1 Data Required

To determine the effectiveness of a given patch type, the highway agency must monitor the repairs for at least 1 year, preferably longer should the repairs survive. Monitoring repairs simply consists of checking for the presence of the repairs and noting the survival or failure of each one. The time elapsed from installation to monitoring is also noted. Table 1 contains a typical collection of patch performance data.

Figure 10 illustrates several plots of patch survival over time. In all three cases, the percentage of patches remaining at the end of monitoring is the same. However, material B would have the highest patch survival rating and the longest average expected patch life when compared with materials A and C.

5.2 Calculations

5.2.1 Patch survival rating

The patch survival rate is defined as the area under the patch survival curve over time. To calculate the area, table 2 can be used for any available patch survival data. As an example, the data from table 1 have been used to calculate a patch survival rate.

Table 1. Sample patch performance data.

Time (weeks) (T_T)	In-place repairs (R_{IP})	Failed repairs (R_F)	Repairs lost to overlay (R_L)	Percent surviving (P_{SURV})
0 (Inst.)	30	0	0	100
4	28	2	0	93
10	26	2	2	93
16	24	3	3	89
30	20	7	3	74
40	19	8	3	70
52	15	10	5	60

$$P_{SURV} = \{R_{IP} / (R_F + R_{IP})\} \times 100$$

Each average percent surviving (P_{AVG}) is calculated by averaging the two percent surviving values that straddle the line being calculated, as shown in the two shaded portions of table 2. Each time interval (T_T) is calculated by subtracting the smaller time ($T_{(i)}$) from the larger time ($T_{(i+1)}$) for the two lines straddling the line being calculated.

Each partial area (A_{PART}) is calculated by multiplying the P_{AVG} and T_T values for that line. Each total possible area (A_{TOT}) is the time interval (T_T) multiplied by 100. The total possible area (A_{TOT}) represents the best possible performance that can be expected for a patch type (100-percent survival for the interval observed). One advantage to this method is that the survival rating can be calculated for any time interval and can be updated easily as additional data are collected.

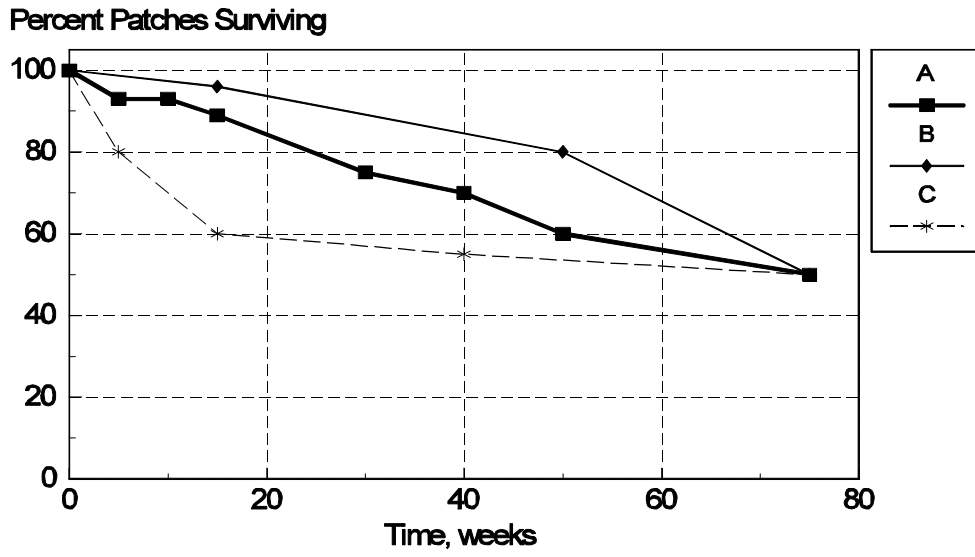

Figure 10. Example of patch survival curves.

Table 2. Worksheet for calculating patch survival rate.

Observ. no. (I)	Time (weeks) (T)	Percent surviving (P_{SURV})	Average percent surviving (P_{AVG})	Time interval (T_T)	Partial area (A_{PART})	Total possible area (A_{TOT})
0	0	100				
1	4	93	96.5	4	386	400
2	10	93	93	6	558	600
3	16	89	91	6	546	600
4	30	74	81.5	14	1141	1400
5	40	70	72	10	720	1000
6	52	60	65	12	780	1200
7						
8						
9						
10						
11						
12						
13						
14						
15						
16						
				Total	4131	5200

Patch Survival Rate
 $(SA_{PART})/(SA_{TOT}) \times 100$

79.4

$$P_{AVG} = (P_{SURV(I)} + P_{SURV(I+1)})/2$$

$$T_T = T_{(I+1)} - T_{(I)}$$

$$A_{PART} = P_{AVG} \times T_T$$

$$A_{TOT} = T_T \times 100$$

5.2.2 Expected average repair life

The average repair life is needed to calculate the cost-effectiveness of the patching operation using the worksheet and formulas shown in chapter 3. To calculate the average life, the observed period of performance is needed for each repair that is monitored. For repairs lost to overlays, no survival time is needed.

As an example of how to calculate the expected average repair life, the data from table 1 will be used. Table 3 shows how the survival data collected over time are converted into the average life value.

Table 3. Worksheet for calculating average repair life.

(A) Time (weeks)	(B) Surviving to this point (S_i)	(C) Failed to this point (F_i)	(D) New failures ($F_{i-1} - F_i$)	(A × D)
0	30	0	2	0
4	28	2	0	0
10	26	2	1	10
16	24	3	4	64
30	20	7	1	30
40	19	8	2	80
52	15	10	15 ^a	780
Total			25	964

^a Number surviving at last inspection.

Average life = $(964/25) = 38.6$ weeks

Inspection period = 52 weeks

Appendix A

Material Testing

An agency involved in pothole patching conducts materials testing that generally falls into one of two categories:

- Compatibility testing for new combinations of asphalt and aggregate to be used in producing cold-mix materials.
- Acceptance testing for new cold-mix materials produced by proprietary sources.

This appendix suggests testing methods for each of these categories. The testing methods are based on previous studies (Anderson et al., 1988; Tam and Lynch, 1987; Carpenter and Wilson, 1991).

These testing methods are intended to provide information concerning combinations of materials or cold-mix materials with which an agency has no prior experience. Testing may not be necessary when agencies are using cold-mix materials that have been successfully used in the past and that do not need confirmation of quality. However, testing these materials could provide reference values to be compared with other cold mixes.

A.1 Compatibility Testing Procedure

When combining asphaltic cement and aggregate to produce cold-mix patching materials, there are several criteria for success:

- The asphalt should coat the aggregate well and remain coated, even after being stockpiled and subjected to various climatic conditions.
- The stockpiled material should remain workable and be easy to handle with shovels. (The outside crust of the stockpile may harden as the asphalt cement hardens, but this skin should prevent the inner material from hardening, so that when a loader breaks through the outer skin, the material is workable again.)
- The material should remain in the holes where it is placed.

The following testing plan presents a series of simple laboratory tests to determine the ability of a particular asphalt-aggregate combination to meet all the requirements listed above. These tests can also identify a range of optimum asphalt content for materials determined to be compatible. The compatibility testing procedure involves three tests: coating, stripping, and drainage.

A.1.1 Coating test

1. Obtain samples of asphalt binder (emulsion or cutback) and aggregate proposed for production of cold mix. The aggregate should fall within the same gradation as the material that will be used for full-scale production. Aggregate samples should be approximately 2,000 g in weight.
2. Dry aggregate samples at approximately 60°C. Stir the samples to prevent formation of lumps.
3. Mix dried aggregate and binder in proportion so that the residual asphalt content would be 4.0 percent. Enter the weights of both aggregate and the asphalt binder in columns C and D of table A-1. Continue mixing until the binder is dispersed throughout the mixture.
4. Spread mixture onto absorbent paper to dry. If desired, the mixture can be placed in an oven at 96°C to speed the drying process.
5. Continue to mix and dry batches of aggregate and binder at the residual asphalt contents listed in column A of table A-1. If mixture becomes soupy at any asphalt content, do not mix batches with any higher asphalt content.
6. When the mixtures are dry, estimate the percentage of aggregate covered with asphalt for each mixture. Enter the coating values for each mixture in column E of table A-1.
7. Enter the lowest asphalt content at which the coating value is at least 90 percent on line F below table A-1. The technician performing the test should judge whether the coating is acceptable.

Table A-1. Data table for coating test.

Emulsion residual factor from specification testing:
 _____(R)

(A) Residual asphalt content, percent	(B) Emulsion content, percent (A/R)	(C) Aggregate weight, g	(D) Emulsion weight, g (C × B)	(E) Percent coating, percent
4.0				
4.5				
5.0				
5.5				
6.0				
6.5				
7.0				
7.5				
8.0				

Minimum asphalt content value for 90-percent coating:
 _____(F)

A.1.2 Stripping test

1. Prepare five aggregate samples of approximately 1,100 g. Heat the samples to 60°C. Part of each sample will be used in the drainability test that follows.
2. Beginning with the minimum value from the coating test (F), mix the aggregate and asphalt samples, recording the actual weights of aggregate and binder used in columns G and I of table A-2. Increase the asphalt content in 0.5-percent increments for the remaining samples to be mixed. Do not increase asphalt content if mix becomes soupy during mixing.
3. Verify that the percent coated is greater than 90 percent for each of the samples mixed.
4. Remove approximately 100 g of mixture and allow to cool to room temperature. Set aside the remaining 1,000 g from each sample for the drainability test.
5. Place the 100-g sample of mixture into a 1-liter jar filled with distilled water. Place jar into an oven at 60°C for 16 to 18 hours.
6. After heating, shake the jar vigorously for approximately 5 seconds, and then pour off the water. Spread the mixture on absorbent paper.
7. Estimate the coating of the mix as was done in the coating test. Record the percentage of aggregate coated in columns K and L of table A-2. Record on line M the minimum asphalt content at which the coating is greater than 90 percent. The technician performing the test should judge whether the coating is acceptable.

Table A-2. Data table for stripping test

Emulsion residual factor: _____ (R)

Minimum asphalt content from coating test: _____(F)

(G) Aggregate weight, g	(H) Desired emulsion weight, g	(I) Actual emulsion weight, g	(J) Actual asphalt content, percent $(I/G) \times 100 \times R$	Percent coated	
				(K) Initial	(L) Final
	$G \times [F / (100 \times R)]$				
	$G \times [(F + 0.5) / (100 \times R)]$				
	$G \times [(F + 1.0) / (100 \times R)]$				
	$G \times [(F + 1.5) / (100 \times R)]$				
	$G \times [(F + 2.0) / (100 \times R)]$				
	$G \times [(F + 2.5) / (100 \times R)]$				
	$G \times [(F + 3.0) / (100 \times R)]$				

Minimum asphalt content for stripping test: _____(M)

A.1.3 Drainage test

1. Record the weights of several 25-cm-diameter disposable aluminum pie pans in row N of table A-3.
2. Place the 1,000-g sample from the stripping test into an aluminum pie pan and enter the weight of the sample with the pie pan and the sample alone in rows O and P of table A-3.
3. Place mixtures (on the pie pans) into a 60 °C oven for 24 hours.
4. After heating, remove the mixture from the pie pan by turning the pan over and tapping the bottom until all aggregate particles are off the pan.
5. Enter the weight of the pie pan with asphalt residue in row Q of table A-3.
6. Determine the highest asphalt content with a drainability of less than 4 percent of the original weight of asphalt, as calculated in row T, and record it on line U beneath table A-3.

Table A-3. Data table for drainage test.

Minimum asphalt content from coating test: _____(F)

Emulsion residual factor: _____(R)

Desired asphalt content, percent	F	F+0.5	F+1.0	F+1.5	F+2.0	F+2.5
(J) Actual asphalt content, percent						
(N) Pie pan weight, g						
(O) Pie pan and sample weight, g						
(P) Sample weight, g						
(Q) Pie pan and asphalt weight, g						
(S) Asphalt weight, g (Q-N)						
(T) Percentage drained, $[S/(P \times J)] \times 100$						

Maximum asphalt content with drainage less than 4 percent: _____(U)

When the three tests have been completed, the values of the asphalt contents determined by coating and stripping (F and M) will represent lower boundaries for the true optimum asphalt content, and the asphalt content determined by the drainage test (U) will represent an upper boundary. As these tests are being performed, the compatibility of the asphalt and aggregate combination will become apparent. If the asphalt content for acceptable drainability is below that for stripping and coating, the combination is unlikely to perform well in the field.

These testing procedures are intended to give a rough idea of the optimum asphalt content and to identify those combinations of asphalt binder and aggregate that would perform poorly in the field in terms of coating, stripping, and drainability. However, even reasonable values for the different tests do not guarantee that the material will perform satisfactorily in actual patching applications.

A.2 Acceptance Testing Procedure

For materials the agency will purchase in premixed form, tests should ensure that the material will not perform poorly in the field. The two tests suggested for acceptance attempt to quantify two important characteristics of cold mixes: workability and cohesion. As with the compatibility testing procedure, these tests do not guarantee success for the materials tested; rather, they indicate the potential for poor performance in the proposed materials.

A.2.1 Workability test

This test requires a workability box, a pocket penetrometer (normally used for soil testing), and a penetrometer adapter. Figure A-1 illustrates the necessary equipment.

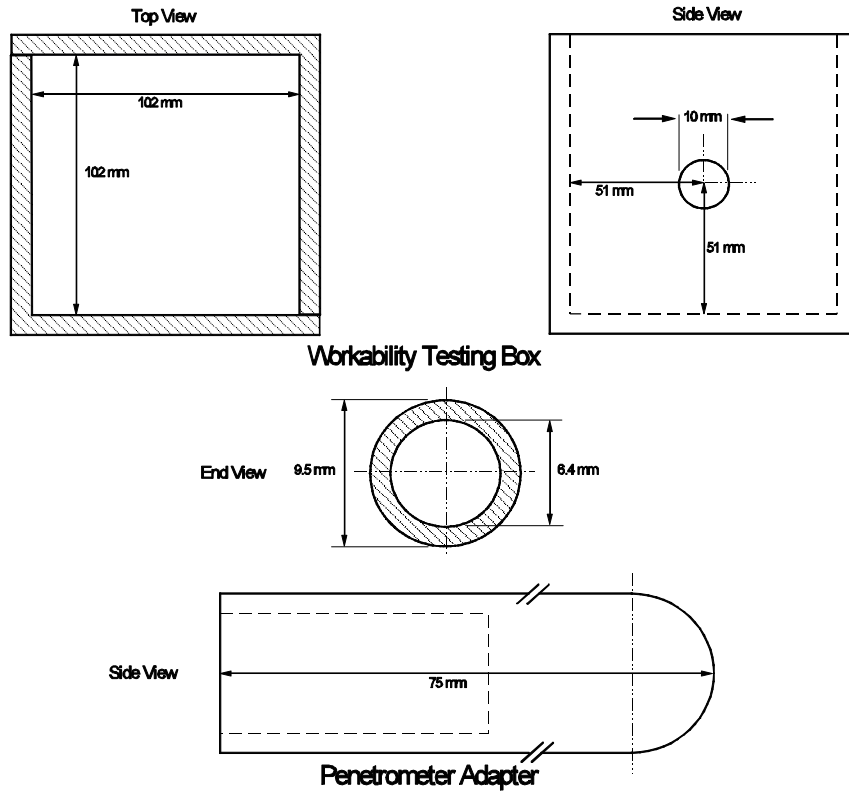

Figure A-2. Workability testing box and penetrometer adapter.

The workability box should measure 102 mm on all sides and should have a 10-mm hole in one side. The Soiltest CL 700-A is one acceptable penetrometer; it has a scale of 0 to 53 metric tons per m², with a 6.4-mm-diameter end. The penetrometer adapter will increase the diameter of the penetrometer to 9.5 mm.

1. Prepare three samples of cold mix of approximately 2,500 g and cool the samples to 4°C.
2. Place the cooled mixture into the workability box. Drop the mixture loosely into the box, making no effort to pack the material into the box.
3. Push the penetrometer with the adapter through the holes in both sides of the box. Record the maximum resistance as the workability measurement.
4. Repeat steps 2 and 3 for all three samples. Calculate the average workability measurements for all samples.

An average workability reading between 3 and 4 would be considered marginal, whereas a value greater than 4 should be rejected. Values less than 3 are acceptable.

A.2.2 Cohesion test

1. Cool several 1,200-g samples of cold mix to a temperature of 4°C.
2. Place the cold mix into a standard Marshall mold, 63.5 mm high, with a diameter of 102 mm. Compact the sample using five blows of a standard Marshall hammer (4.5 kg) to each side, from a drop height of 457 mm.
3. Extrude the sample and record the weight of the compacted sample.
4. Place the compacted sample along the bottom edge of a 305-mm-diameter sieve while both the sieve and the sample are standing on end, as shown in figure A-2.

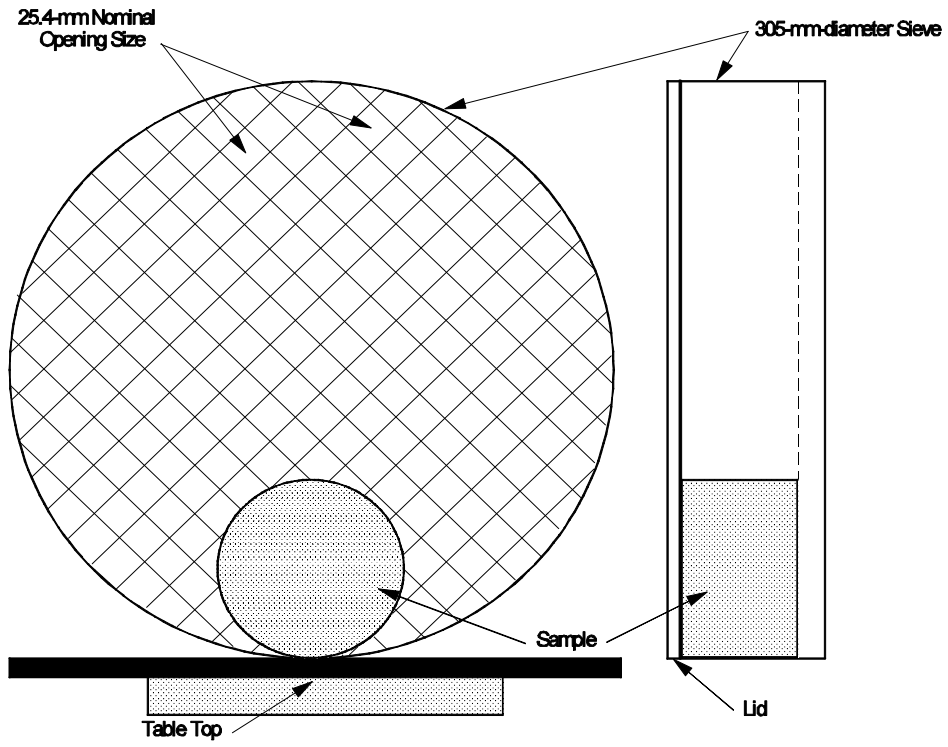

Figure A-2. Rolling sieve cohesion test.

5. Place the cover on the sieve while it is still on end. Roll the sieve (with the sample inside) back and forth 20 times, taking approximately 1 second for each of the 20 passes.
6. Lay the sieve (with the sample still inside) against the edge of a table, allowing room for sample pieces to fall through the sieve openings. Leave the sieve in this position for 10 seconds.
7. Flip the sieve and lid over so that the sample in the sieve falls onto the lid. Weigh the material retained.
8. Determine the average percentage retained by dividing the weight retained by the original weight. A minimum retention value of 60 percent is recommended for this test.

Appendix B

Sample Cost-Effectiveness Calculations

This appendix contains sample worksheets for cost-effectiveness calculations. Different material and procedure combinations illustrate the financial differences between patching operations. The examples demonstrate how to use the worksheet for calculating the cost-effectiveness of several different pothole patching operations (figures B-1 through B-5). These examples illustrate the differences in materials, procedures, equipment, and location when performing pothole patching operations. Values for the variables are given below.

Example 1

Material	Local cold mix
Method	Throw-and-roll
Cost	\$20 per metric ton
Patching Crew Size	2 laborers
Traffic Control Crew	2 laborers
Daily Wage	\$100 per day per laborer
Equipment Cost	\$20 per day (material truck) \$25 per day (traffic control)
Productivity	4 metric tons per day
Patch Mean Survival	3 months
Analysis Period	36 months
User Delay Costs	\$1,000 per day

Example 2

Material	UPM High-Performance Cold Mix
Method	Throw-and-roll
Cost	\$85 per metric ton
Patching Crew Size	2 laborers
Traffic Control Crew	2 laborers
Daily Wage	\$100 per day per laborer
Equipment Cost	\$20 per day (material truck) \$25 per day (traffic control)
Productivity	4 metric tons per day
Patch Survival Rate	30 months
Analysis Period	36 months
User Delay Costs	\$1,000 per day

Example 3

Material	Local cold mix
Method	Semi-permanent
Cost	\$20 per metric ton
Patching Crew Size	4 laborers 1 supervisor
Traffic Control Crew	2 laborers
Daily Wage	\$100 per day per laborer \$120 per day per supervisor
Equipment Cost	\$20 per day (material truck) \$25 per day (traffic control) \$10 per day (preparation) \$5 per day (compaction) \$10 per day (equipment truck)
Productivity	1.5 metric tons per day
Patch Mean Survival	36 months
Analysis Period	36 months
User Delay Costs	\$1,000 per day

Example 4

Material	Spray injection
Method	Spray injection
Cost	\$0 per metric ton
Patching Crew Size	0 laborers
Traffic Control Crew	2 laborers
Daily Wage	\$100 per day per laborer
Equipment	\$750 per day (spray-injection device, crew, and material)
Productivity	4 metric tons per day
Patch Mean Survival	30 months
Analysis Period	36 months
User Delay Costs	\$1,000 per day

Example 5

Material	Local cold mix
Method	Throw-and-roll
Cost	\$20 per metric ton
Patching Crew Size	2 laborers
Traffic Control Crew	2 laborers
Daily Wage	\$100 per day per laborer
Equipment Cost	\$20 per day (material truck) \$25 per day (traffic control)
Productivity	4 metric tons per day
Patch Mean Survival	3 months
Analysis Period	36 months
User Delay Costs	\$10,000 per day

MATERIAL COSTS			
Material Purchase Cost	20	\$/metric ton	(A)
Material Shipping Cost	0	\$/metric ton	(B)
Anticipated Material Needs	200	metric tons	(C)
LABOR COSTS			
Number in Patching Crew	2		(D)
Average Daily Wage per Person	100	\$/day	(E)
Number in Traffic Control Crew	2		(F)
Average Daily Wage per Person	100	\$/day	(G)
Supervisor Daily Wage	0	\$/day	(H)
EQUIPMENT COSTS			
Material Truck	20	\$/day	(I)
Traffic Control Truck and Signs	25	\$/day	(J)
Preparation Equipment (e.g., compressor, jackhammer, pavement saw)	0	\$/day	(K)
Compaction Equipment (e.g., vibratory plate, single-drum)	0	\$/day	(L)
Extra Equipment Truck	0	\$/day	(M)
Specialty Equipment (e.g., spray-injection device)	0	\$/day	(N)
USER COSTS			
User Delay Costs	1,000	\$/day	(O)

Figure B-1. Cost worksheet for example 1.

Total Material Cost [(A+B)×C]	4,000	\$	(P)
Total Daily Labor Cost [(D×E)+(F×G)+H]	400	\$/day	(Q)
Total Equipment Cost (I+J+K+L+M+N)	45	\$/day	(R)
Average Daily Productivity	4	metric tons/day	(S)
Estimated Days for Initial Patching Operation (C÷S)	50	days	(T)
Total User, Labor, and Equipment Cost [(O+Q+R)×T]	72,250	\$	(U)
Total Labor and Equipment Cost [(Q+R)×T]	22,250	\$	(V)
Total Patching Operation Cost With User Costs (P+U)	76,250	\$	(W)
Total Patching Operation Cost Without User Costs (P+V)	26,250	\$	(X)
Expected Patch Survival	3	months	(Y)
Patching Analysis Period	36	months	(Z)
Effective Patching Operation Cost With User Costs [W×(Z÷Y)]	915,000	\$	(AA)
Effective Patching Operation Cost Without User Costs [X×(Z÷Y)]	315,000	\$	(BB)
Cost per Original Pothole Volume With User Costs [AA×(2.0÷C)]	9,150	\$/m ³	(CC)
Cost per Original Pothole Volume Without User Costs [BB×(2.0÷C)]	3,150	\$/m ³	(DD)

Figure B-1. Cost worksheet for example 1 (continued).

MATERIAL COSTS			
Material Purchase Cost	75	\$/metric ton	(A)
Material Shipping Cost	10	\$/metric ton	(B)
Anticipated Material Needs	200	metric tons	(C)
LABOR COSTS			
Number in Patching Crew	2		(D)
Average Daily Wage per Person	100	\$/day	(E)
Number in Traffic Control Crew	2		(F)
Average Daily Wage per Person	100	\$/day	(G)
Supervisor Daily Wage	0	\$/day	(H)
EQUIPMENT COSTS			
Material Truck	20	\$/day	(I)
Traffic Control Truck and Signs	25	\$/day	(J)
Preparation Equipment (e.g., compressor, jackhammer, pavement saw)	0	\$/day	(K)
Compaction Equipment (e.g., vibratory plate, single-drum)	0	\$/day	(L)
Extra Equipment Truck	0	\$/day	(M)
Specialty Equipment (e.g., spray-injection device)	0	\$/day	(N)
USER COSTS			
User Delay Costs	1,000	\$/day	(O)

Figure B-2. Cost worksheet for example 2.

Total Material Cost [(A+B)×C]	17,000	\$	(P)
Total Daily Labor Cost [(D×E)+(F×G)+H]	400	\$/day	(Q)
Total Equipment Cost (I+J+K+L+M+N)	45	\$/day	(R)
Average Daily Productivity	4	metric tons/day	(S)
Estimated Days for Initial Patching Operation (C÷S)	50	days	(T)
Total User, Labor, and Equipment Cost [(O+Q+R)×T]	72,250	\$	(U)
Total Labor and Equipment Cost [(Q+R)×T]	22,250	\$	(V)
Total Patching Operation Cost With User Costs (P+U)	89,250	\$	(W)
Total Patching Operation Cost Without User Costs (P+V)	39,250	\$	(X)
Expected Patch Survival	30	months	(Y)
Patching Analysis Period	36	months	(Z)
Effective Patching Operation Cost With User Costs [W×(Z÷Y)]	107,100	\$	(AA)
Effective Patching Operation Cost Without User Costs [X×(Z÷Y)]	47,100	\$	(BB)
Cost per Original Pothole Volume With User Costs [AA×(2.0÷C)]	1,071	\$/m ³	(CC)
Cost per Original Pothole Volume Without User Costs [BB×(2.0÷C)]	471	\$/m ³	(DD)

Figure B-2. Cost worksheet for example 2 (continued).

MATERIAL COSTS			
Material Purchase Cost	20	\$/metric ton	(A)
Material Shipping Cost	0	\$/metric ton	(B)
Anticipated Material Needs	75	metric tons	(C)
LABOR COSTS			
Number in Patching Crew	4		(D)
Average Daily Wage per Person	100	\$/day	(E)
Number in Traffic Control Crew	2		(F)
Average Daily Wage per Person	100	\$/day	(G)
Supervisor Daily Wage	120	\$/day	(H)
EQUIPMENT COSTS			
Material Truck	20	\$/day	(I)
Traffic Control Truck and Signs	25	\$/day	(J)
Preparation Equipment (e.g., compressor, jackhammer, pavement saw)	10	\$/day	(K)
Compaction Equipment (e.g., vibratory plate, single-drum)	5	\$/day	(L)
Extra Equipment Truck	20	\$/day	(M)
Specialty Equipment (e.g., spray-injection device)	0	\$/day	(N)
USER COSTS			
User Delay Costs	1,000	\$/day	(O)

Figure B-3. Cost worksheet for example 3.

Total Material Cost [(A+B)×C]	1,500	\$	(P)
Total Daily Labor Cost [(D×E)+(F×G)+H]	720	\$/day	(Q)
Total Equipment Cost (I+J+K+L+M+N)	80	\$/day	(R)
Average Daily Productivity	1.5	metric tons/day	(S)
Estimated Days for Initial Patching Operation (C÷S)	50	days	(T)
Total User, Labor, and Equipment Cost [(O+Q+R)×T]	90,000	\$	(U)
Total Labor and Equipment Cost [(Q+R)×T]	40,000	\$	(V)
Total Patching Operation Cost With User Costs (P+U)	91,500	\$	(W)
Total Patching Operation Cost Without User Costs (P+V)	41,500	\$	(X)
Expected Patch Survival	24	months	(Y)
Patching Analysis Period	36	months	(Z)
Effective Patching Operation Cost With User Costs [W×(Z÷Y)]	137,250	\$	(AA)
Effective Patching Operation Cost Without User Costs [X×(Z÷Y)]	62,250	\$	(BB)
Cost per Original Pothole Volume With User Costs [AA×(2.0÷C)]	3,660	\$/m ³	(CC)
Cost per Original Pothole Volume Without User Costs [BB×(2.0÷C)]	1,660	\$/m ³	(DD)

Figure B-3. Cost worksheet for example 3 (continued).

MATERIAL COSTS			
Material Purchase Cost	0	\$/metric ton	(A)
Material Shipping Cost	0	\$/metric ton	(B)
Anticipated Material Needs	200	metric tons	(C)
LABOR COSTS			
Number in Patching Crew	0		(D)
Average Daily Wage per Person	0	\$/day	(E)
Number in Traffic Control Crew	2		(F)
Average Daily Wage per Person	100	\$/day	(G)
Supervisor Daily Wage	0	\$/day	(H)
EQUIPMENT COSTS			
Material Truck	0	\$/day	(I)
Traffic Control Truck and Signs	25	\$/day	(J)
Preparation Equipment (e.g., compressor, jackhammer, pavement saw)	0	\$/day	(K)
Compaction Equipment (e.g., vibratory plate, single-drum)	0	\$/day	(L)
Extra Equipment Truck	0	\$/day	(M)
Specialty Equipment (e.g., spray-injection device)	750	\$/day	(N)
USER COSTS			
User Delay Costs	1,000	\$/day	(O)

Figure B-4. Cost worksheet for example 4.

Total Material Cost [(A+B)×C]	0	\$	(P)
Total Daily Labor Cost [(D×E)+(F×G)+H]	200	\$/day	(Q)
Total Equipment Cost (I+J+K+L+M+N)	775	\$/day	(R)
Average Daily Productivity	4	metric tons/day	(S)
Estimated Days for Initial Patching Operation (C÷S)	50	days	(T)
Total User, Labor, and Equipment Cost [(O+Q+R)×T]	88,750	\$	(U)
Total Labor and Equipment Cost [(Q+R)×T]	38,750	\$	(V)
Total Patching Operation Cost With User Costs (P+U)	88,750	\$	(W)
Total Patching Operation Cost Without User Costs (P+V)	38,750	\$	(X)
Expected Patch Survival	30	months	(Y)
Patching Analysis Period	36	months	(Z)
Effective Patching Operation Cost With User Costs [W×(Z÷Y)]	106,500	\$	(AA)
Effective Patching Operation Cost Without User Costs [X×(Z÷Y)]	46,500	\$	(BB)
Cost per Original Pothole Volume With User Costs [AA×(2.0÷C)]	1,065	\$/m ³	(CC)
Cost per Original Pothole Volume Without User Costs [BB×(2.0÷C)]	465	\$/m ³	(DD)

Figure B-4. Cost worksheet for example 4 (continued).

MATERIAL COSTS			
Material Purchase Cost	20	\$/metric ton	(A)
Material Shipping Cost	0	\$/metric ton	(B)
Anticipated Material Needs	200	metric tons	(C)
LABOR COSTS			
Number in Patching Crew	2		(D)
Average Daily Wage per Person	100	\$/day	(E)
Number in Traffic Control Crew	2		(F)
Average Daily Wage per Person	100	\$/day	(G)
Supervisor Daily Wage	0	\$/day	(H)
EQUIPMENT COSTS			
Material Truck	20	\$/day	(I)
Traffic Control Truck and Signs	25	\$/day	(J)
Preparation Equipment (e.g., compressor, jackhammer, pavement saw)	0	\$/day	(K)
Compaction Equipment (e.g., vibratory plate, single-drum)	0	\$/day	(L)
Extra Equipment Truck	0	\$/day	(M)
Specialty Equipment (e.g., spray-injection device)	0	\$/day	(N)
USER COSTS			
User Delay Costs	10,000	\$/day	(O)

Figure B-5. Cost worksheet for example 5.

Total Material Cost [(A+B)×C]	4,000	\$	(P)
Total Daily Labor Cost [(D×E)+(F×G)+H]	400	\$/day	(Q)
Total Equipment Cost (I+J+K+L+M+N)	45	\$/day	(R)
Average Daily Productivity	4	metric tons/day	(S)
Estimated Days for Initial Patching Operation (C÷S)	50	days	(T)
Total User, Labor, Equipment Cost [(O+Q+R)×T]	522,250	\$	(U)
Total Labor and Equipment Cost [(Q+R)×T]	22,250	\$	(V)
Total Patching Operation Cost With User Costs (P+U)	526,250	\$	(W)
Total Patching Operation Cost Without User Costs (P+V)	26,250	\$	(X)
Expected Patch Survival	3	months	(Y)
Patching Analysis Period	36	months	(Z)
Effective Patching Operation Cost With User Costs [W×(Z÷Y)]	6,315,000	\$	(AA)
Effective Patching Operation Cost Without User Costs [X×(Z÷Y)]	315,000	\$	(BB)
Cost per Original Pothole Volume With User Costs [AA×(2.0÷C)]	63,150	\$/m ³	(CC)
Cost per Original Pothole Volume Without User Costs [BB×(2.0÷C)]	3,150	\$/m ³	(DD)

Figure B-5. Cost worksheet for example 5 (continued).

Appendix C

Partial List of Material and Equipment Sources

This appendix contains a directory of manufacturers and representatives who can explain how an agency would obtain any of the materials used in the SHRP H-106 Project. Addresses and phone numbers are given for national representatives of the different proprietary materials and spray-injection devices. Information on obtaining specifications for other materials is also provided.

All manufacturers should provide material safety data sheets where applicable. All highway agencies should follow instructions regarding the safe use of all materials to ensure the safety of their workers and the traveling public.

Inclusion of a particular material, piece of equipment, or supplier in this list does not serve as an endorsement. Likewise, omission from this list is not intended to carry negative connotations for those materials, pieces of equipment, and suppliers. In cases in which some discrepancy exists as to which patch type will perform better for a particular agency, side-by-side testing of all available patch types is encouraged.

C.1 Patching Materials

UPM High-Performance Cold Mix
Unique Paving Materials Corp.
3993 E. 93rd Street
Cleveland, Ohio 44105-4096
(800) 441-4881

QPR 2000
US Pro-Tech
7471 Tyler Boulevard
Mentor, Ohio 44060
(800) 263-7511

Perma-Patch
National Paving and Contracting Company
4200 Menlo Drive
Baltimore, Maryland 21215
(410) 764-7117

HFMS-2 (modified with Styrelf)
Elf Asphalt
Tulsa, Oklahoma
(918) 438-6450

PennDOT 485 and PennDOT 486
IA Construction
P.O. Box 366
Punxsutawney, Pennsylvania 15767
(814) 938-7650

C.2 Patching Equipment

Durapatcher Spray Injection

Duraco Industries
P.O. Box 6127
Jackson, Mississippi 39288-6127
(601) 932-2100

Roadpatcher Spray Injection

Wildcat Manufacturing
P.O. Box 523
Freeman, South Dakota 57029
(605) 925-4512

Asphalite 200 Spray Injection

Rosco Manufacturing Company
1001 S.W. 1st Street
Madison, South Dakota 57042
(605) 256-6942

Patchrite Patching Machine

Patchrite
P.O. Box 3344
1891 Albert Street North
Regina, Saskatchewan S4P 3H1
(306) 543-2020

AMZ

Zimmerman Equipment Corporation
1000 South Thompson Lane
Nashville, Tennessee 37211
(615) 833-5705

TP-4 Pothole Patcher
Akzo Nobel Asphalt Applications, Inc.
Waco, Texas
(800) 283-7226

C.3 Patching Services

RoadPatch Services, Inc.
P.O. Box 191
Mountainhome, Pennsylvania 18342
(800) 468-1108

Glossary

Pothole—Localized distress in an asphalt-surfaced pavement resulting from the breakup of the asphalt surface and possibly the asphalt base course. Pieces of asphalt pavement created by the action of climate and traffic on the weakened pavement are then removed under the action of traffic, leaving a pothole.

Pothole patching—The repair of severe, localized distress in asphalt-surfaced pavements. This maintenance activity is generally done by the agency responsible for the roadway and is intended to be a temporary repair at best. Pothole patching is not intended to be a permanent repair. Full-depth reconstruction of the distressed areas is necessary for a permanent repair in most instances.

Semi-permanent—Repair technique for potholes in asphalt-surfaced pavements that includes removing water and debris from the pothole before placing repair material. Once the pothole has been cleaned, the edges of the distress are straightened using a pavement saw, jackhammer, milling machine, or similar equipment. After the edges have been straightened and are in sound pavement, the cold mix is placed. The patch is compacted using a single-drum vibratory roller or a vibratory-plate compactor.

Spray injection—Repair technique for potholes in asphalt-surfaced pavements and spalls in portland cement concrete (PCC)-surfaced pavements that uses a spray-injection device. Spray-injection devices are capable of spraying heated emulsion, virgin aggregate, or both into a distress location.

Throw-and-go—Repair technique using cold-mix patching materials in which the material is shoveled into the pothole with no preparation of the pothole until it is filled; compaction of the patch is left to passing traffic, while the maintenance crew moves on to the next distress location.

Throw-and-roll—Repair technique using cold-mix patching materials in which the material is shoveled into the pothole with no preparation of the pothole until it is filled; the material truck tires are used to compact the patch before the crew moves on to the next distress location.

References

- Anderson, D.A., et al. 1988. *More Effective Cold, Wet-Weather Patching Materials for Asphalt Pavements*, Federal Highway Administration, Report No. FHWA-RD-88-001.
- Carpenter, S.H. and T.P. Wilson. 1991. *Evaluations of Improved Cold-Mix Binders—Field Operations Plan*, Federal Highway Administration, Contract No. DTFH61-90-00021.
- Evans, L.D., et al. 1993. *Materials and Procedures for Pavement Repairs—Final Report*, National Research Council, Strategic Highway Research Program, Contract SHRP-89-H-106.
- Smith, K.L., et al. 1991. *Innovative Materials and Equipment for Pavement Surface Repairs—Final Report*, National Research Council, Strategic Highway Research Program, Contract No. SHRP-M/UFR-91-504.
- Tam, K.K. and D.F. Lynch. 1987. *New Methods for Testing Workability and Cohesion of Cold Patching Material*, Ontario Ministry of Transportation, Engineering Materials Office, Bituminous Section.
- Wilson, T.P. 1998. *Long-Term Monitoring of Pavement Maintenance Materials Test Sites*, Final Report, Publication No. FHWA-RD-98-073, Federal Highway Administration, McLean, Virginia.