

Dynamic Properties of Stay Cables on the Leonard P. Zakim Bunker Hill Bridge

PUBLICATION NO. FHWA-HRT-21-058

MAY 2021



U.S. Department of Transportation
Federal Highway Administration

Research, Development, and Technology
Turner-Fairbank Highway Research Center
6300 Georgetown Pike
McLean, VA 22101-2296

FOREWORD

Cable-stayed bridge configurations have become more common over the past several decades for bridges in the medium- to long-span range. Nonetheless, in some cases, serviceability problems involving large-amplitude vibrations of stay cables under certain wind and wind-rain conditions have been observed. This study was conducted in response to State transportation department interest in developing improved design guidance for mitigation of excessive cable vibrations on cable-stayed bridges. The study included full-scale forced vibration tests on the cables of a new cable-stayed bridge to characterize the dynamic behavior of cables and evaluate the effectiveness of mitigation details such as crosssties. The results of this study will be made available to the Post-Tensioning Institute's DC-45 Cable-Stayed Bridge Committee for consideration during periodic updates of their *Recommendations for Stay Cable Design, Testing and Installation* publication.⁽¹⁾

This report will be of interest to bridge engineers, wind engineers, and consultants involved in the design of cable-stayed bridges. It is the sixth in a series of reports addressing the subject of aerodynamic stability of bridge stay cables.⁽²⁻⁶⁾

Cheryl Allen Richter, P.E., Ph.D.
Director, Office of Infrastructure
Research and Development

Notice

This document is disseminated under the sponsorship of the U.S. Department of Transportation (USDOT) in the interest of information exchange. The U.S. Government assumes no liability for the use of the information contained in this document.

The U.S. Government does not endorse products or manufacturers. Trademarks or manufacturers' names appear in this report only because they are considered essential to the objective of the document.

Quality Assurance Statement

The Federal Highway Administration (FHWA) provides high-quality information to serve Government, industry, and the public in a manner that promotes public understanding. Standards and policies are used to ensure and maximize the quality, objectivity, utility, and integrity of its information. FHWA periodically reviews quality issues and adjusts its programs and processes to ensure continuous quality improvement.

TECHNICAL REPORT DOCUMENTATION PAGE

1. Report No. FHWA-HRT-21-058		2. Government Accession No.		3. Recipient's Catalog No.	
4. Title and Subtitle Dynamic Properties of Stay Cables on the Leonard P. Zakim Bunker Hill Bridge				5. Report Date May 2021	
				6. Performing Organization Code	
7. Author(s) Harold R. Bosch and James R. Pagenkopf (ORCID ID: 0000-0001-5392-8628)				8. Performing Organization Report No.	
9. Performing Organization Name and Address Genex Systems, LLC 11848 Rock Landing Drive, Suite 303 Newport News, VA 23606				10. Work Unit No.	
				11. Contract or Grant No. DTFH61-13-D-00011	
12. Sponsoring Agency Name and Address Office of Infrastructure Research and Development Federal Highway Administration 6300 Georgetown Pike McLean, VA 22101				13. Type of Report and Period Covered Laboratory Report; December 2003– December 2008	
				14. Sponsoring Agency Code HRDI-40	
15. Supplementary Notes The Contracting Officer's Representative was Harold R. Bosch (HRDI-40).					
16. Abstract Cable-stayed bridges have been recognized as the most efficient and cost effective structural form for medium- to long-span bridges over the past several decades. With their widespread use, cases of serviceability problems associated with large-amplitude vibration of stay cables have been reported. ⁽²⁾ Stay cables are laterally flexible structural members with low inherent damping and thus are highly susceptible to environmental conditions such as wind and rain–wind combinations. Recognition of these problems led to incorporating different types of mitigation measures on many cable-stayed bridges around the world. These measures included surface modifications, cable crossies, and external (or internal) dampers. Modification of cable surfaces has been widely accepted as a means to mitigate rain–wind vibrations. Recent studies have firmly established the formation of a water rivulet along the upper side of the stay and its interaction with wind flow as the main cause of rain–wind vibrations. Appropriate modification of exterior cable surface effectively disrupts the formation of a water rivulet. ^(7–10) The objective of this study was to supplement the existing knowledgebase as to some of the outstanding issues of stay-cable vibrations and develop technical recommendations that may be incorporated into design guidelines. Specifically, this project focused on identifying in-situ cable dynamic properties and assessing the performance of dampers and crossies on the Leonard P. Zakim Bunker Hill Bridge. Forced vibration tests were conducted on the stay cables during the latter stages of construction, just prior to and following installation of dampers as well as before and after installation of a single line of crossies. Cable properties, such as vibration frequencies and damping levels, were established and compared with design targets. The measured levels of inherent damping in the cables were low, as expected, and the resulting low Scruton numbers confirmed the need to install cable crossies.					
17. Key Words Cable-stayed bridges, cables, vibrations, wind, rain, crossies, dampers, hazard mitigation				18. Distribution Statement No restrictions. This document is available to the public through National Technical Information Service, Springfield, VA 22161. http://www.ntis.gov	
19. Security Classif. (of this report) Unclassified		20. Security Classif. (of this page) Unclassified		21. No. of Pages 184	22. Price N/A

SI* (MODERN METRIC) CONVERSION FACTORS

APPROXIMATE CONVERSIONS TO SI UNITS

Symbol	When You Know	Multiply By	To Find	Symbol
LENGTH				
in	inches	25.4	millimeters	mm
ft	feet	0.305	meters	m
yd	yards	0.914	meters	m
mi	miles	1.61	kilometers	km
AREA				
in ²	square inches	645.2	square millimeters	mm ²
ft ²	square feet	0.093	square meters	m ²
yd ²	square yard	0.836	square meters	m ²
ac	acres	0.405	hectares	ha
mi ²	square miles	2.59	square kilometers	km ²
VOLUME				
fl oz	fluid ounces	29.57	milliliters	mL
gal	gallons	3.785	liters	L
ft ³	cubic feet	0.028	cubic meters	m ³
yd ³	cubic yards	0.765	cubic meters	m ³
NOTE: volumes greater than 1,000 L shall be shown in m ³				
MASS				
oz	ounces	28.35	grams	g
lb	pounds	0.454	kilograms	kg
T	short tons (2,000 lb)	0.907	megagrams (or "metric ton")	Mg (or "t")
TEMPERATURE (exact degrees)				
°F	Fahrenheit	5 (F-32)/9 or (F-32)/1.8	Celsius	°C
ILLUMINATION				
fc	foot-candles	10.76	lux	lx
fl	foot-Lamberts	3.426	candela/m ²	cd/m ²
FORCE and PRESSURE or STRESS				
lbf	poundforce	4.45	newtons	N
lbf/in ²	poundforce per square inch	6.89	kilopascals	kPa

APPROXIMATE CONVERSIONS FROM SI UNITS

Symbol	When You Know	Multiply By	To Find	Symbol
LENGTH				
mm	millimeters	0.039	inches	in
m	meters	3.28	feet	ft
m	meters	1.09	yards	yd
km	kilometers	0.621	miles	mi
AREA				
mm ²	square millimeters	0.0016	square inches	in ²
m ²	square meters	10.764	square feet	ft ²
m ²	square meters	1.195	square yards	yd ²
ha	hectares	2.47	acres	ac
km ²	square kilometers	0.386	square miles	mi ²
VOLUME				
mL	milliliters	0.034	fluid ounces	fl oz
L	liters	0.264	gallons	gal
m ³	cubic meters	35.314	cubic feet	ft ³
m ³	cubic meters	1.307	cubic yards	yd ³
MASS				
g	grams	0.035	ounces	oz
kg	kilograms	2.202	pounds	lb
Mg (or "t")	megagrams (or "metric ton")	1.103	short tons (2,000 lb)	T
TEMPERATURE (exact degrees)				
°C	Celsius	1.8C+32	Fahrenheit	°F
ILLUMINATION				
lx	lux	0.0929	foot-candles	fc
cd/m ²	candela/m ²	0.2919	foot-Lamberts	fl
FORCE and PRESSURE or STRESS				
N	newtons	2.225	poundforce	lbf
kPa	kilopascals	0.145	poundforce per square inch	lbf/in ²

*SI is the symbol for International System of Units. Appropriate rounding should be made to comply with Section 4 of ASTM E380. (Revised March 2003)

TABLE OF CONTENTS

CHAPTER 1. INTRODUCTION	1
CHAPTER 2. THEORETICAL BACKGROUND	3
Vibration of Taut String with Distributed Damping	3
Determination of Damping Ratios	4
CHAPTER 3. EXPERIMENTAL PROCEDURES	7
The Test Bridge	7
Setup and Procedures	13
CHAPTER 4. PHASE 1 INVESTIGATION	19
Testing	19
Analysis	19
Frequency Content	19
Damping Analysis	20
Discussion	27
Frequency Content	27
Damping Ratios	28
Scruton Number Analysis	29
CHAPTER 5. PHASE 2 INVESTIGATION	31
Testing	31
Analysis	31
Frequency Content	31
Damping Analysis	32
Discussion	35
Frequency Content	35
Damping Ratios	36
Scruton Number Analysis	36
CHAPTER 6. PHASE 3 INVESTIGATION	39
Testing	39
Analysis	39
Frequency Content	39
Damping Analysis	40
Discussion	44
Frequency Content	44
Damping Ratios	45
Scruton Number Analysis	45
CHAPTER 7. SUMMARY OF COMPARISONS	47
Frequency	47
Damping	48
Scruton Number	50
CHAPTER 8. THEORETICAL FREQUENCIES AND COMPUTER MODELING	53
Methods	53
Frequency Comparisons	54

Crosstie Analysis	64
Mode Frequency Evolution.....	68
CHAPTER 9. CONCLUSIONS.....	71
APPENDIX A. MODE FREQUENCY TABLES	73
APPENDIX B. MODE FREQUENCY PLOTS	93
APPENDIX C. DAMPING RATIO TABLES.....	97
APPENDIX D. CABLE PROPERTIES.....	171
REFERENCES.....	173

LIST OF FIGURES

Figure 1. Photo. The Leonard P. Zakim Bunker Hill Bridge during construction.	2
Figure 2. Equation. Equation of motion (EOM) for a string.	3
Figure 3. Equation. General solution of EOM.	3
Figure 4. Equation. EOM for a string in terms of natural frequency and damping ratio.	3
Figure 5. Equation. General solution to EOM.	4
Figure 6. Equation. Damped natural frequency.	4
Figure 7. Equation. Ratio of two consecutive peaks.	4
Figure 8. Equation. Logarithmic decrement.	4
Figure 9. Equation. Damping ratio.	5
Figure 10. Map. Location of the Leonard P. Zakim Bunker Hill Bridge site. ⁽¹⁴⁾	7
Figure 11. Illustration. Bridge plan and elevation. ⁽¹⁵⁾	8
Figure 12. Illustration. Typical bridge plan cross section for the main span. ⁽¹⁶⁾	9
Figure 13. Illustration. Cable numbering system for the (a) side-span face and (b) main-span face of the tower.	10
Figure 14. Illustration. Full cable fan arrangement for (a) the side span supporting the center of the deck versus (b) the main span supporting the edges of the deck.	11
Figure 15. Photo. Detailed view of a damper.	12
Figure 16. Photo. Line of cross-ties connecting several cables.	12
Figure 17. Photo. Installation of accelerometer on a stay cable.	13
Figure 18. Photo. Accelerometer box mounted on a cable.	14
Figure 19. Photo. Inside view of accelerometer's box enclosure.	15
Figure 20. Photo. Data acquisition system.	15
Figure 21. Illustration. Location of accelerometers during testing.	16
Figure 22. Illustration. Arrangement of cables tested.	19
Figure 23. Graph. Phase 1 spectral density plot of cable S02.	20
Figure 24. Graph. Effect of the bandpass filter on spectral density (a) before and (b) after.	21
Figure 25. Graph. Phase 1 plots comparing (a) original, (b) bandpass-filtered, and (c) truncated time series.	21
Figure 26. Graph. Marked peaks of the decay curve.	22
Figure 27. Graph. Closer view of the marked peaks.	22
Figure 28. Graph. Best-fit line of the natural log of the peaks.	23
Figure 29. Graph. Closer view of a 20-s interval of the best-fit line of the peaks.	23
Figure 30. Graph. Phase 1: first mode with 90-percent confidence interval on the mean for north-tower cables.	24
Figure 31. Graph. Phase 1: first mode with 90-percent confidence interval on the mean for south-tower cables.	25
Figure 32. Graph. Phase 1: second mode with 90-percent confidence interval on the mean for north-tower cables.	25
Figure 33. Graph. Phase 1: second mode with 90-percent confidence interval on the mean for south-tower cables.	26
Figure 34. Graph. First-mode frequencies from phase 1 testing for (left to right) side-span, main-span east, and main-span west cables.	28
Figure 35. Equation. Scruton number.	29
Figure 36. Graph. Phase 2 spectral density plot of cable N01.	31

Figure 37. Graph. Phase 2 plots comparing (a) original, (b) bandpass-filtered, and (c) truncated time series.....	32
Figure 38. Graph. Phase 2: first mode with 90-percent confidence interval on the mean for north-tower cables.	33
Figure 39. Graph. Phase 2: first mode with 90-percent confidence interval on the mean for south-tower cables.....	33
Figure 40. Graph. Phase 2: second mode with 90-percent confidence interval on the mean for north-tower cables.	34
Figure 41. Graph. Phase 2: second mode with 90-percent confidence interval on the mean for south-tower cables.	34
Figure 42. Graph. First-mode frequencies from phase 2 testing for (left to right) side-span, main-span east, and main-span west cables.	36
Figure 43. Illustration. Arrangement of cables tested in phase 3.....	39
Figure 44. Graph. Phase 3 spectral density plot of cable S33W.....	40
Figure 45. Graph. Phase 3 plots comparing (a) original, (b) bandpass-filtered, and (c) truncated time series.....	40
Figure 46. Graph. Phase 3: first mode with 90-percent confidence interval on the mean for north-tower cables.	41
Figure 47. Graph. Phase 3: first mode with 90-percent confidence interval on the mean for south-tower cables.....	42
Figure 48. Graph. Phase 3: second mode with 90-percent confidence interval on the mean for north-tower cables.	42
Figure 49. Graph. Phase 3: second mode with 90-percent confidence interval on the mean for south-tower cables.	43
Figure 50. Graph. Phase 3 spectral density plot for cable N03.....	44
Figure 51. Graph. First-mode frequencies from phase 3 testing for (left to right) side-span, main-span east, and main-span west cables.	45
Figure 52. Graph. Comparison of first-mode frequencies for all phases for (left to right) side-span, main-span east, and main-span west cables.	47
Figure 53. Graph. Comparison of second-mode frequencies for all phases for (left to right) side-span, main-span east, and main-span west cables.	48
Figure 54. Graph. Comparison of first-mode damping ratios for north-tower cables.	49
Figure 55. Graph. Comparison of first-mode damping ratios for south-tower cables.....	49
Figure 56. Graph. Comparison of second-mode damping ratios for north-tower cables.	50
Figure 57. Graph. Comparison of second-mode damping ratios for south-tower cables.	50
Figure 58. Graph. Comparison of Scruton numbers for north-tower cables.	51
Figure 59. Graph. Comparison of Scruton numbers for south-tower cables.	51
Figure 60. Graph. First-mode frequency comparison for phase 1 conditions for south tower side-span cables.....	54
Figure 61. Graph. First-mode frequency comparison for phase 1 conditions for south tower main-span cables on the east side.....	55
Figure 62. Graph. First-mode frequency comparison for phase 1 conditions for south tower main-span cables on the west side.....	55
Figure 63. Graph. First-mode frequency comparison for phase 1 conditions for north tower side-span cables.....	56

Figure 64. Graph. First-mode frequency comparison for phase 1 conditions for north tower main-span cables on the east side.....	56
Figure 65. Graph. First-mode frequency comparison for phase 1 conditions for north tower main-span cables on the west side.....	57
Figure 66. Graph. First-mode frequency comparison for phase 2 conditions for south tower side-span cables.....	57
Figure 67. Graph. First-mode frequency comparison for phase 2 conditions for south tower main-span cables on the east side.....	58
Figure 68. Graph. First-mode frequency comparison for phase 2 conditions for south tower main-span cables on the west side.....	58
Figure 69. Graph. First-mode frequency comparison for phase 2 conditions for north tower side-span cables.....	59
Figure 70. Graph. First-mode frequency comparison for phase 2 conditions for north tower main-span cables on the east side.....	59
Figure 71. Graph. First-mode frequency comparison for phase 2 conditions for north tower main-span cables on the west side.....	60
Figure 72. Graph. First-mode frequency comparison for phase 3 conditions for south tower side-span cables.....	61
Figure 73. Graph. First-mode frequency comparison for phase 3 conditions for south tower main-span cables on the east side.....	61
Figure 74. Graph. First-mode frequency comparison for phase 3 conditions for south tower main-span cables on the west side.....	62
Figure 75. Graph. First-mode frequency comparison for phase 3 conditions for north tower side-span cables.....	62
Figure 76. Graph. First-mode frequency comparison for phase 3 conditions for north tower main-span cables on the east side.....	63
Figure 77. Graph. First-mode frequency comparison for phase 3 conditions for north tower main-span cables on the west side.....	63
Figure 78. Image. Vibration mode shapes of the south tower side span with no crossies for the (a) first, (b) second, (c) third, and (d) fourth modes.....	65
Figure 79. Image. Vibration mode shapes of the south tower main span with no crossies for the (a) first, (b) second, (c) third, and (d) fourth modes.....	66
Figure 80. Image. Vibration mode shapes of the south tower side span with a single line of crossies for the (a) first, (b) second, (c) third, and (d) fourth modes.....	67
Figure 81. Image. Vibration mode shapes of the south tower main span with a single line of crossies for the (a) first, (b) second, (c) third, and (d) fourth modes.....	68
Figure 82. Graph. Mode-frequency evolution comparing crossie configurations for the south tower side span.....	69
Figure 83. Graph. Mode-frequency evolution comparing crossie configurations for the south tower main span.....	69
Figure 84. Graph. Comparison of third-mode frequencies for all phases for (left to right) main-span, side-span east, and side-span west cables.....	93
Figure 85. Graph. Comparison of fourth-mode frequencies for all phases for (left to right) main-span, side-span east, and side-span west cables.....	93
Figure 86. Graph. Comparison of fifth-mode frequencies for all phases for (left to right) main-span, side-span east, and side-span west cables.....	94

Figure 87. Graph. Comparison of sixth-mode frequencies for all phases for (left to right)
main-span, side-span east, and side-span west cables..... 94

Figure 88. Graph. Comparison of seventh-mode frequencies for all phases for (left to right)
main-span, side-span east, and side-span west cables..... 95

LIST OF TABLES

Table 1. Summary of accelerometer locations.....	17
Table 2. Phase 1 summary of results.	27
Table 3. Phase 1 Scruton number.	30
Table 4. Phase 2 summary of results data.....	35
Table 5. Phase 2 Scruton number.	37
Table 6. Phase 3 summary of results data.....	43
Table 7. Phase 3 Scruton numbers.....	46
Table 8. Phase 1 mode frequencies (Hz).	73
Table 9. Phase 1 averaged mode frequencies (Hz).	78
Table 10. Phase 2 mode frequencies (Hz).	79
Table 11. Phase 2 averaged mode frequencies (Hz).	85
Table 12. Phase 3 mode frequencies (Hz).	86
Table 13. Phase 3 average mode frequencies (Hz).	92
Table 14. Phase 1, box 1, first-mode damping data.....	97
Table 15. Phase 1, box 2, first-mode damping data.....	102
Table 16. Phase 1, box 1, second-mode damping data.	107
Table 17. Phase 1, box 2, second-mode damping data.	112
Table 18. Phase 1 summary of average damping values.	117
Table 19. Phase 2, box 1, first-mode damping data.....	119
Table 20. Phase 2, box 2, first-mode damping data.....	125
Table 21. Phase 2, box 1, second-mode damping data.	131
Table 22. Phase 2, box 2, second-mode damping data.	137
Table 23. Phase 2 summary of average damping values.	143
Table 24. Phase 3, box 1, first-mode damping data.....	145
Table 25. Phase 3, box 2, first-mode damping data.....	151
Table 26. Phase 3, box 1, second-mode damping data.	157
Table 27. Phase 3, box 2, second-mode damping data.	163
Table 28. Phase 3 summary of average damping values.	169
Table 29. General properties of tested cables.	171

LIST OF ABBREVIATIONS AND SYMBOLS

Abbreviations

DOF	degree of freedom
EOM	equation of motion
FHWA	Federal Highway Administration
HDPE	high-density polyethylene
IED	internal elastomeric dampers
MassDOT	Massachusetts Department of Transportation
PSD	power spectral density

Symbols

A_n	Amplitude of in-plane displacement due to the n th mode of vibration
c	viscous damping coefficient per unit length
D	diameter of cable pipe
F_n	natural frequency of the n th mode of vibration
g	gravitational constant
H	pretension of string or cable
L	length of string or cable
L_1, L_2	chord length distance along cable to boxes 1 or 2
m	mass density per unit length
N	total number of modes
n	mode number
Sc	nondimensional Scruton number
T_{dn}	damped natural period of the n th mode of vibration
t	time
u_n	time-dependent part of transverse displacement due to n th mode of vibration
$w(x, t)$	transverse displacement, w , at distance, x , and time, t
α_n	phase angle of time-dependent part of transverse in-plane displacement due to n th mode of vibration
δ	nondimensional logarithmic decrement ratio
ζ	first-mode damping ratio
ζ_n	nondimensional damping ratio of the n th mode of vibration
ρ	mass density of air
ω_n	natural angular frequency of the n th mode of vibration
ω_{dn}	damped natural angular frequency of the n th mode of vibration

CHAPTER 1. INTRODUCTION

Of particular importance to structural engineers and bridge owners is the dynamic behavior of a bridge deck's supporting cables for cable-stayed bridges. These structurally critical components are often excited into several vibration modes by ambient wind conditions. Studying the damped behavior of cables is fundamental to ensuring a safe and structurally sound system.

Stay-cable vibration up to amplitudes of 6.5 ft (2 m) under conditions of moderate wind, sometimes in conjunction with light rain, has been observed with increasing frequency in recent years.⁽¹⁾ This problem is not new and has been studied extensively over a period of several decades; however, gaps remain in understanding the problem. With a growing inventory of cable-stayed bridges, reports of large amplitude cable vibrations have increased. Some structures have been retrofitted to mitigate these vibrations. Cable-stayed bridges under design or construction are currently incorporating dampers, crossties, aerodynamic surface treatments, or a combination thereof into the cable system. While retrofits have been deployed to fix existing problems, and mitigation details have been evolving for new structural designs, few full-scale investigations have been conducted either to establish the detailed site or structural conditions or to evaluate the effectiveness of mitigation measures. To fill the information gap, the Federal Highway Administration (FHWA) has performed long-term monitoring of cables on existing cable-stayed bridges and has conducted vibration tests on cables during various stages of construction on new bridges.

The Leonard P. Zakim Bunker Hill Bridge is a cable-stayed bridge in downtown Boston, MA. It carries eight lanes of I-93, as well as a two-lane ramp, across the Charles River. The bridge opened to the public on March 30, 2003. During construction, the former Massachusetts Highway Department (which has since merged into the Massachusetts Department of Transportation (MassDOT)) and FHWA agreed to test the longer stay cables to determine their mode frequencies and damping ratio values before and after installation of dampers as well as before and after the installation of crossties. Figure 1 shows a photo of the bridge during construction.



© 2001 MassDOT.

Figure 1. Photo. The Leonard P. Zakim Bunker Hill Bridge during construction.

One line of cross ties is installed in each cable fan based on specifications determined by the bridge designers. These short-term tests served to establish and benchmark cable properties, such as vibration frequencies and inherent damping of each stay cable, the additional damping provided by internal dampers installed on each cable, and stiffness provided by cross ties. Information obtained in this study can be used not only for assessing whether design objectives have been met but also for cataloging representative cable properties and making comparisons with future measurements to determine whether performance has changed, which could potentially require inspection, repairs, or both.

CHAPTER 2. THEORETICAL BACKGROUND

As first discussed in a 2014 FHWA study of the Penobscot Narrows Bridge in Maine, the following sections reiterate the theoretical underpinnings for studying the dynamic properties of in situ cables as well as crosstie performance.⁽⁵⁾

VIBRATION OF TAUT STRING WITH DISTRIBUTED DAMPING

The transverse vibration of a taut string with uniformly distributed viscous damping can be described by the following equation in figure 2:⁽¹²⁾

$$m \frac{\partial^2 w}{\partial t^2} + c \frac{\partial w}{\partial t} = H \frac{\partial^2 w}{\partial x^2}$$

Figure 2. Equation. Equation of motion (EOM) for a string.

Where:

m = mass density per unit length.

$w(x,t)$ = transverse displacement, w , at distance, x , and time, t .

c = viscous damping coefficient per unit length.

H = pretension of the string or cable.

For a string of length L , fixed at both ends, $w(x,t)$ can be approximated by a finite degree-of-freedom (DOF) system, as defined in figure 3:

$$w(x,t) \cong \sum_{n=1}^N \sin \frac{n\pi x}{L} u_n(t)$$

Figure 3. Equation. General solution of EOM.

Where:

N = total number of modes.

n = mode number.

L = length of string or cable.

u_n = time-dependent part of transverse displacement due to n th mode of vibration.

t = time.

The sinusoidal spatial functions $\sin(n\pi x/L)$ in figure 3 represent the normal modes for a string where $c = 0$. Substituting $w(x,t)$ into the equation in figure 2 and rearranging yields the equation in figure 4, as follows:

$$\ddot{u}_n(t) + 2\zeta_n \omega_n \dot{u}_n + \omega_n^2 u_n = 0 \quad \text{where } \omega_n = \sqrt{\frac{H}{m}} \frac{n\pi}{L} \quad \text{and } \zeta_n = \frac{c}{2m\omega_n}$$

Figure 4. Equation. EOM for a string in terms of natural frequency and damping ratio.

Where:

- ζ_n = nondimensional damping ratio of the n th mode of vibration.
- ω_n = natural angular frequency of the n th mode of vibration.

The equation in figure 4 represents the equation of motion for the n th mode vibration of the string, ω_n and ζ_n respectively, which denote the corresponding natural angular frequency and damping ratio of the mode. The equations for this N -DOF system are fully decoupled, and each mode can be handled separately. Using the standard solution technique for a single DOF system, a general solution to the equation in figure 4 is shown in figure 5:⁽¹³⁾

$$u_n(t) = A_n e^{-\zeta_n \omega_n t} \cos(\omega_{dn} t - \alpha_n)$$

Figure 5. Equation. General solution to EOM.

Where:

- A_n = amplitude of in-plane displacement due to the n th mode of vibration.
- ω_{dn} = damped natural angular frequency of the n th mode of vibration.
- α_n = phase angle of time-dependent part of transverse in-plane displacement due to n th mode of vibration.

This damped natural frequency is related to natural frequency by the equation shown in figure 6:

$$\omega_{dn} \equiv \omega_n \sqrt{1 - \zeta_n^2}$$

Figure 6. Equation. Damped natural frequency.

DETERMINATION OF DAMPING RATIOS

The damping ratio, or the fraction of critical damping, ζ_n , can be estimated experimentally. In the logarithmic decrement method, the damping ratio is found by measuring the amplitude of two consecutive peaks of damped free vibration and computing their ratio.⁽¹³⁾ The ratio between the two consecutive peaks of the vibration is given by the expression shown in figure 7:

$$\frac{u_n(t)}{u_n(t + T_{dn})} = \exp(\zeta_n \omega_n T_{dn}) = \exp\left(\frac{2\pi\zeta_n}{\sqrt{1 - \zeta_n^2}}\right)$$

Figure 7. Equation. Ratio of two consecutive peaks.

where T_{dn} is the damped natural period of the n th mode, equal to $2\pi/\omega_{dn}$. Selecting two consecutive peaks u_i and u_{i+1} and taking the natural logarithm of the equation in figure 7, the expression for the logarithmic decrement, δ , is defined by figure 8 as follows:

$$\delta \equiv \ln\left(\frac{u_i}{u_{i+1}}\right) = \frac{2\pi\zeta_n}{\sqrt{1 - \zeta_n^2}}$$

Figure 8. Equation. Logarithmic decrement.

For lightly damped systems ($\zeta_n < 0.2$), the equation in figure 8 can be simplified to $\delta \cong 2\pi\zeta_n$. This simplification is valid for most stay cables, whose inherent damping ratios are almost always lower than 0.01. From this simplification and the equation in figure 8, the damping ratio can be obtained by applying the equation in figure 9:

$$\zeta_n \cong \left(\frac{1}{2\pi}\right) \ln\left(\frac{u_i}{u_{i+1}}\right)$$

Figure 9. Equation. Damping ratio.

The equation in figure 9 is valid for both displacement and acceleration-decay curves for lightly damped systems.

CHAPTER 3. EXPERIMENTAL PROCEDURES

THE TEST BRIDGE

The Leonard P. Zakim Bunker Hill Bridge is a cable-stayed bridge that carries 10 lanes of traffic across the Charles River in Boston, MA. The bridge, constructed as part of Boston's massive "Big Dig" transportation project, was completed in 2003 and connects four northbound and four southbound lanes of Interstate 93 and U.S. Route 1 over the main span with an additional two northbound lanes cantilevered off the northeast side of the bridge. A map of the bridge site and the surrounding area is shown in figure 10. The total length of the bridge is 1,432 ft (436 m) including a main span of 745 ft (227 m). The bridge replaced the Charlestown High Bridge, a double-decked truss structure originally built in 1954 that had since been overwhelmed by increasing traffic flow.

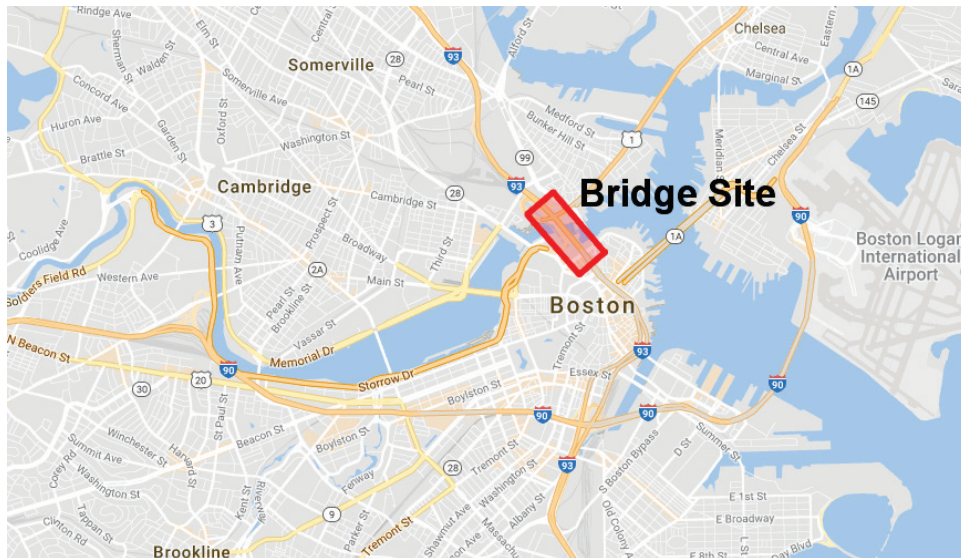

Map © 2017 Google®. Modifications by FHWA. The original map shown in figure 10 is the copyright property of Google Maps® and can be accessed from <https://maps.google.com>. The map contains an overlay labeling the bridge site and was developed for this research project.

Figure 10. Map. Location of the Leonard P. Zakim Bunker Hill Bridge site.⁽¹⁴⁾

Prior to completing construction on the Leonard P. Zakim Bunker Hill Bridge, FHWA was requested to test the stay cables and determine their natural frequencies and damping ratios before and after installation of internal dampers as well as before and after the installation of cross-ties. An overview of the bridge plan is shown in figure 11, while figure 12 shows a typical cross section of the deck. The span cross section consists of a 136.5-ft (41.6-m)-wide deck that has an additional 46.75 ft (14.25 m) cantilevered deck section on the east side. The main section of the deck consists of two sections of 56-ft (17.1-m)-wide roadway separated by a 10-ft (3-m)-wide center barrier. Each direction of roadway consists of four 12-ft (3.7-m)-wide lanes flanked by 4-ft (1.2-m)-wide shoulders on either side. The cantilevered roadway on the northeast side consists of two additional 12-ft (3.7-m)-wide lanes flanked by 4-ft (1.2-m)-wide shoulders whose edges are protected by concrete barriers.

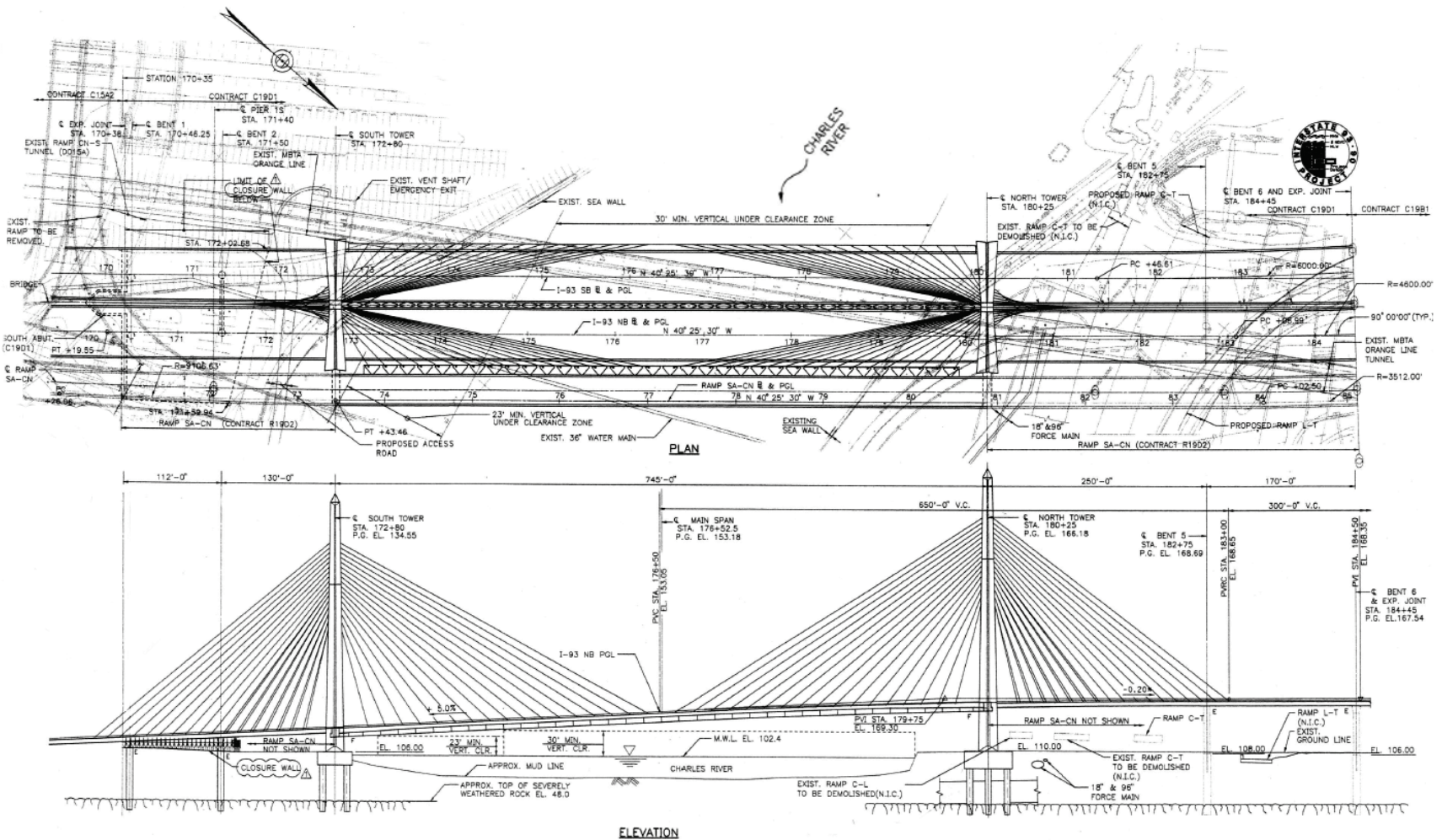

Blueprint © 1997 MassDOT. Modified for clarity by FHWA.

Figure 11. Illustration. Bridge plan and elevation.⁽¹⁵⁾

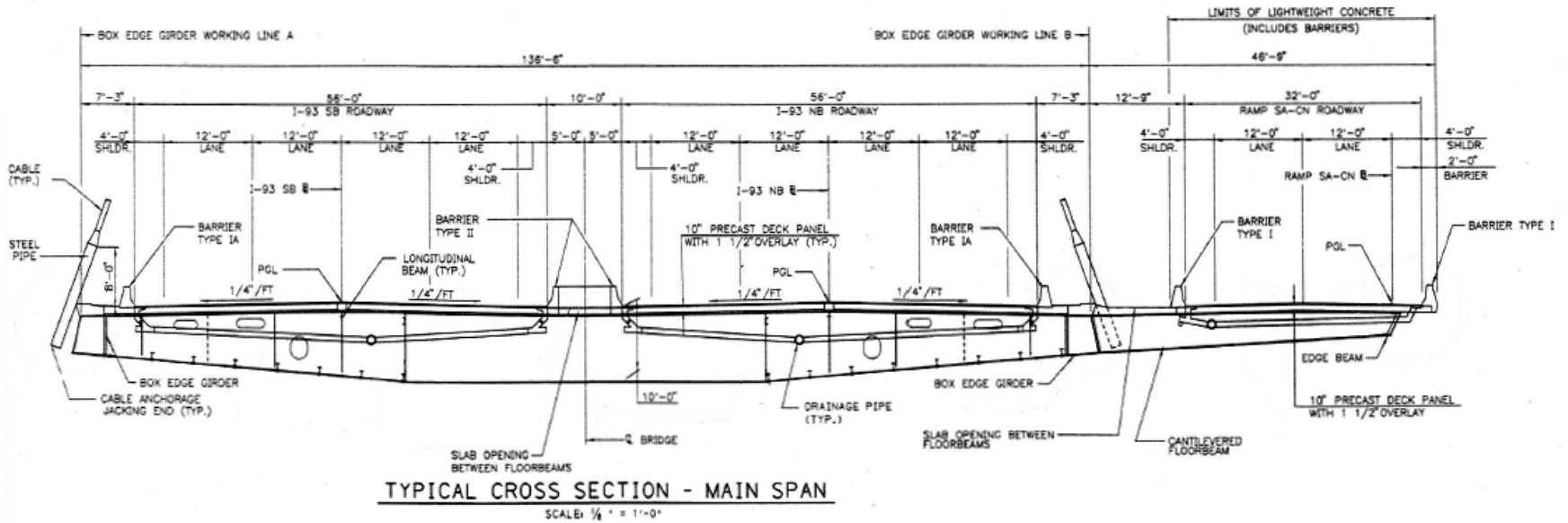

Blueprint © 1997 MassDOT. Modified for clarity by FHWA.

Figure 12. Illustration. Typical bridge plan cross section for the main span.⁽¹⁶⁾

The bridge has two unique, inverted-Y-shaped towers that vary in height between 310 and 343 ft (94.5 and 104.4 m) with different arrangements of cable geometry supporting the main versus the side spans of the bridge (figure 13). The side-span faces of the towers support 24 cables whose lower anchorages are in the center of the bridge deck. The longest 10 cables, labeled 1 to 10, are mounted in the upper tower, while the remaining 14 cables alternately separate down the east and west sides of the inverted Y and are labeled 11E to 17E and 11W to 17W, respectively. The cables on the main-span faces of the towers are arranged slightly differently, with two symmetrical sets of 17 cables with lower anchorages located at its outer edges of the bridge deck. These sets of cables are labeled 18E to 34E and 18W to 34W, respectively. Figure 14 shows the full profile view of both sides of the taller north tower, illustrating the difference in cable arrangements between the side span supporting the center of the deck and main span supporting the edges of the deck. The two towers are designated north and south and, in this report, the cables associated with each tower are given the prefix “N” or “S” (e.g., N34E indicates cable 34 on the north tower’s east side). In figure 11, the south tower is shown on the left side of the illustration, and the north tower is shown on the right.

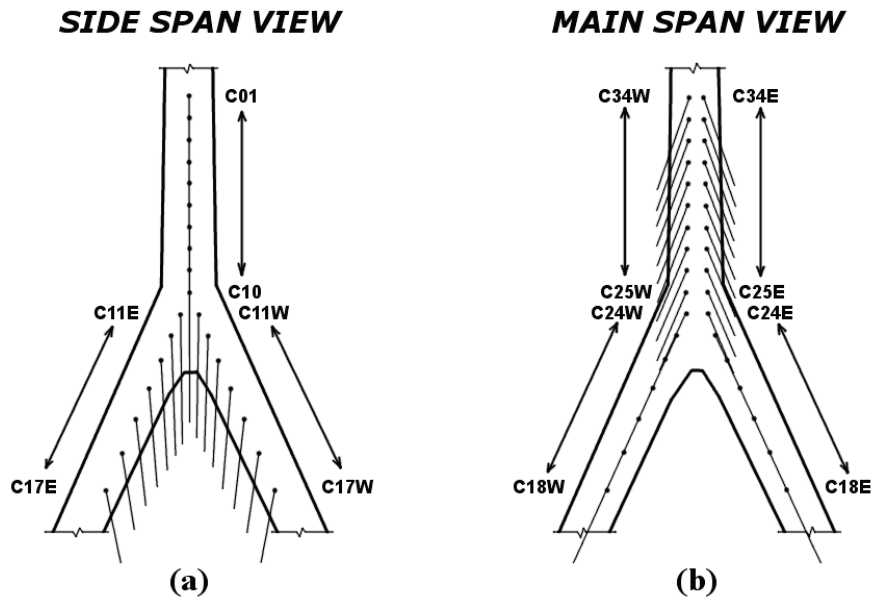

Source: FHWA.

Figure 13. Illustration. Cable numbering system for the (a) side-span face and (b) main-span face of the tower.

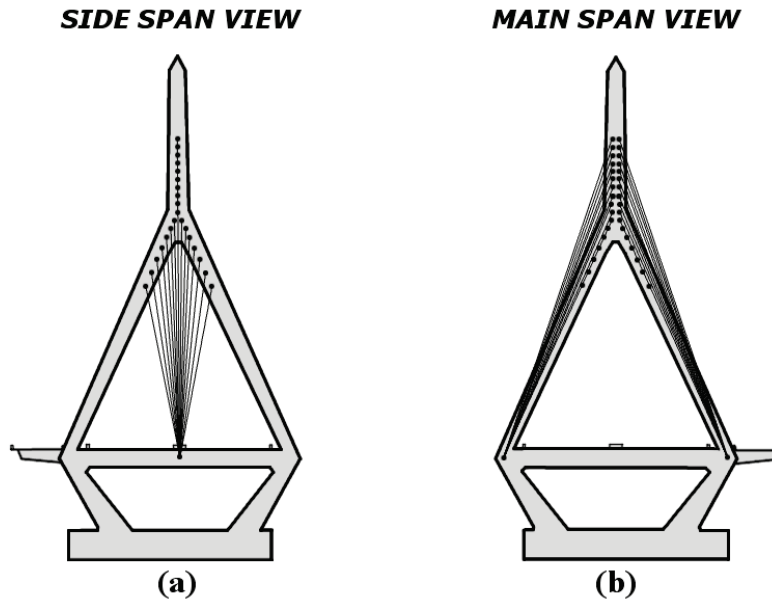

Source: FHWA.

Figure 14. Illustration. Full cable fan arrangement for (a) the side span supporting the center of the deck versus (b) the main span supporting the edges of the deck.

The side-span cables range in length from 139.1 to 363.2 ft (42.4 to 110.7 m), while the main-span cables range from 140.8 to 421.6 ft (42.9 to 128.5 m). The cables consist of 14 to 77 steel-wire strands inside an ungrouted, coextruded, high-density polyethylene (HDPE) pipe. At the lower end of the cables, near the bridge deck, the cables are protected by a painted steel antivandalism pipe that also houses an internal oil damper. The HDPE pipe varies in diameter between 5.91 and 9.84 inches (15 to 25 cm), depending on the number of strands in the cable, and has a double-helix spiral fillet on the surface. Each 0.62-inch (15.7-mm)-diameter seven-wire strand is filled with grease and encased in an extruded HDPE sheath. It is worthwhile to note that the original stay system was to be grouted; however, during latter design and early construction phases, it was changed to an ungrouted system.

The dampers used on the Leonard P. Zakim Bunker Hill Bridge were internal elastomeric dampers (IED), which is an elastomeric ring made of a viscoelastic material that is X-shaped in cross section. The damper recommended for the bridge was the IED+ model, which includes an oil-filled silicone bladder placed in the outer portion of the ring to help absorb energy. The dampers were installed at deck-level within the antivandalism pipe to improve aesthetics while still allowing easy access for maintenance personnel. Figure 15 shows a photo of the damper mounted on the steel strands before it was covered by the antivandalism pipe.

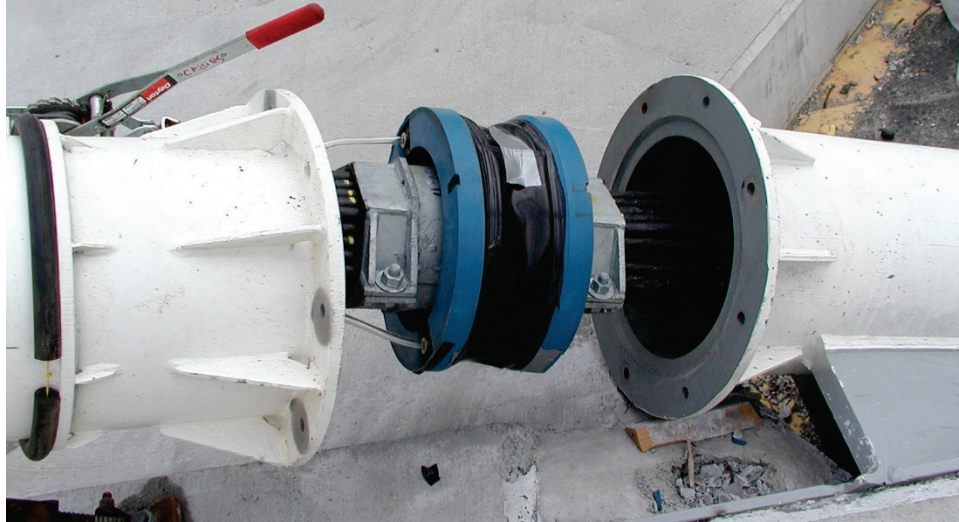

Source: FHWA.

Figure 15. Photo. Detailed view of a damper.

A single line of crossties was used in each fan on both sides of each tower. Figure 16 shows a photo of a line of crossties connecting several cables. On the side spans, the crosstie connected the longest nine cables before anchoring to the bridge deck near the base of the 10th cable. On the main spans, both the east and west groupings of cables had their own line of crossties connecting the 10 longest cables before anchoring to the bridge deck near the base of the 11th cable. The crossties were mounted normal to the longest stay, and each segment consisted of a 0.75-inch (19-mm)-diameter flexible wire rope that is attached to a two-piece steel clamp mounted on the cable. Each clamp was large enough to distribute transverse force on the HDPE pipe and had tie connections designed to minimize moment forces on the cable. The segments contained an adjustable turnbuckle for introducing pretensions between the stays.

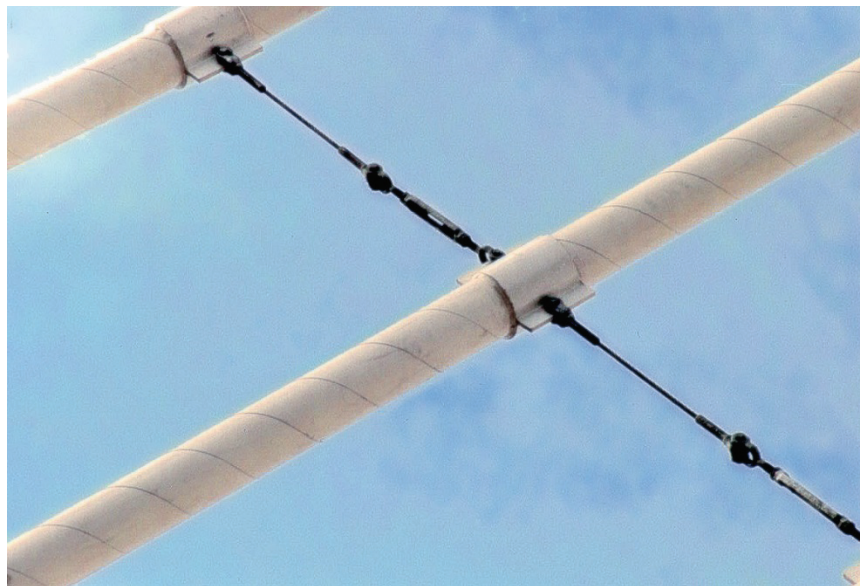

Source: FHWA.

Figure 16. Photo. Line of crossties connecting several cables.

SETUP AND PROCEDURES

Dynamic testing of the stay cables on the Leonard P. Zakim Bunker Hill Bridge was performed by staff from the FHWA Aerodynamics Lab in three phases across a 5-month period. The first phase of measurements took place after the cables had been installed but before the dampers were attached and operational. The second phase was conducted 3 months later, after the installation of dampers was completed. The third and final phase occurred after a single line of crossties had been installed in each cable fan.

Data from the vibration testing were obtained by attaching dual triaxial accelerometer boxes to each stay cable, the first box being roughly 25 percent up the length of the cable and the second being 39 ft up the length of the cable (figure 17). The lower box, or enclosure, was positioned far enough away from the end of the antivandalism pipe to register significant oscillations, while the upper box was placed closer to the eventual location of the future crossties. Figure 18 shows a closeup view of a box strapped onto a cable. For phase 3 testing, the box locations were modified after the introduction of crossties. Box 1 was then located three-quarters of the length to the crosstie from the end of the antivandalism pipe, while box 2 was located halfway between the end of the pipe and the crosstie.



Source: FHWA.

Figure 17. Photo. Installation of accelerometer on a stay cable.

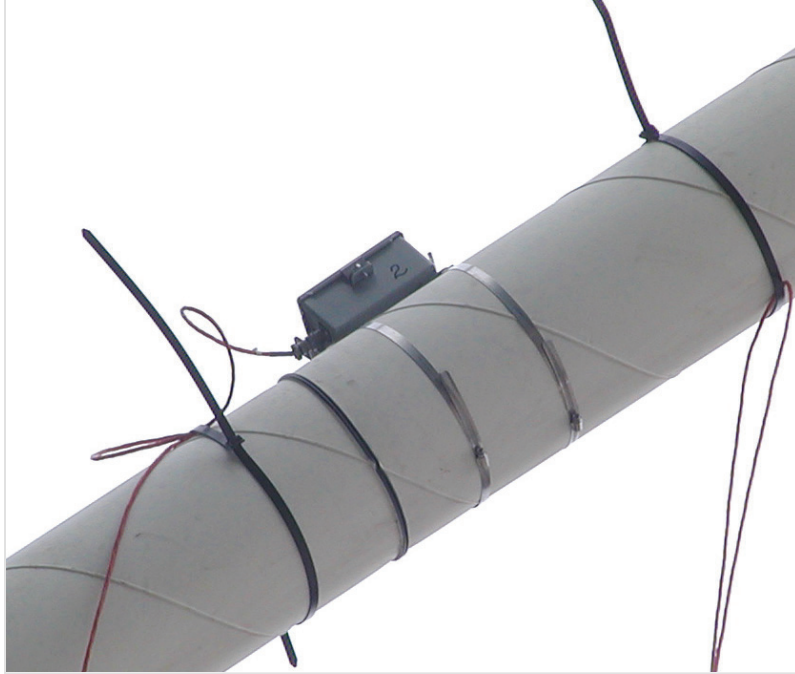

Source: FHWA.

Figure 18. Photo. Accelerometer box mounted on a cable.

Multiple boxes ensured that useable data would be collected even in the case of a malfunctioning sensor or if a sensor was inadvertently stationed at a frequency node. The accelerometers measured data from all three axes, although only data from the in-plane direction were required for analysis. The in-plane direction corresponds to the vertical plane of cables, which was measured as the z -direction on the accelerometer. Figure 19 shows the inside of one of the box enclosures, including the accelerometer and the 9-V power supply. Data from the accelerometers were recorded using a portable data acquisition system, which is shown in figure 20. The scan frequency used for the accelerometers was 100 Hz.

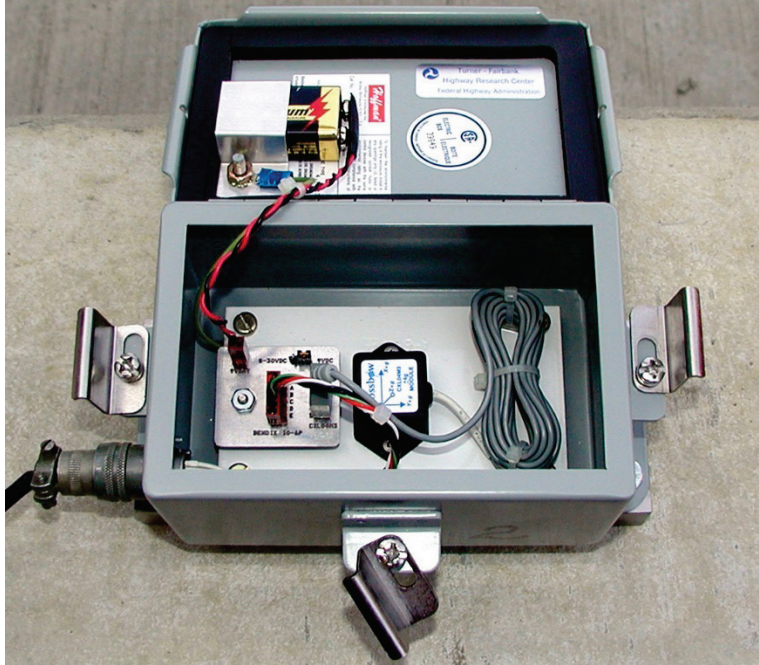

Source: FHWA.

Figure 19. Photo. Inside view of accelerometer's box enclosure.



Source: FHWA.

Figure 20. Photo. Data acquisition system.

The cables were manually excited in the vertical plane with a pull rope while a spotter checked to make sure the proper amplitudes and modes were achieved. Positioned with a good view along the longitudinal axis of the cable under test, the spotter would signal the “pullers” to synchronize the pulling action with the cable motions. This approach enabled efficient excitation, vibrations (primarily in the first vertical mode), and peak amplitudes of one cable diameter or more. When the cable reached a sufficient excitation, the rope was released, allowing the cable to freely

oscillate and the vibrations to decay. The data acquisition system would be triggered to start recording before the excitation was started then continued recording until the decay subsided and only random traffic- or wind-induced vibrations remained. Between four to eight test runs were attempted on each cable.

Since this was FHWA's first series of forced vibration tests on ungrouted stay cables, there was concern that the loose steel strands might not move in phase with the HDPE pipe during excitation. Lab staff held discussions with the bridge designer to determine if and where spacers (or centralizers) would be used during bridge construction to anchor the strands in place within the HDPE pipe. During early test runs, it was observed that with either aggressive forced vibration or relatively large amplitude excitation, the steel strands would audibly bang against the inside of the HDPE pipe. In subsequent test runs, the cable puller took extra care to minimize any clashing between the strands and pipe.

In addition to the data recorded from the sensors, general test notes were taken regarding sensor locations, weather conditions, quality of the vibration modes achieved, interference from construction activities, and any difficulties encountered while exciting the cable. Figure 21 shows a diagram of a stay cable illustrating the distance between each accelerometer and the anchor block, with L_1 defined as the chord length distance along the cable to box 1 and L_2 defined as the chord length distance along the cable to box 2. Table 1 contains a summary of the positioning distances used for boxes 1 and 2 on each cable during testing.

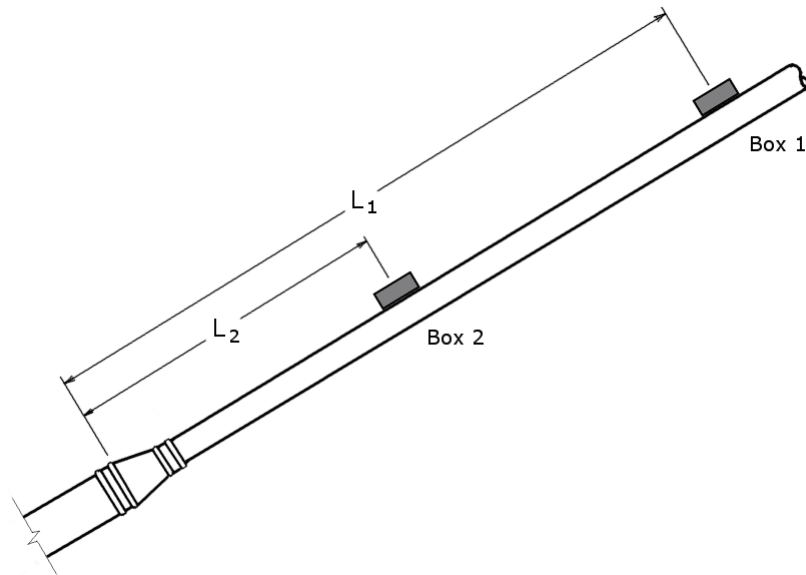

Source: FHWA.

Figure 21. Illustration. Location of accelerometers during testing.

Table 1. Summary of accelerometer locations.

Cable	Phases 1 and 2		Phase 3	
	L_1 (ft)	L_2 (ft)	L_1 (ft)	L_2 (ft)
N01	87.90	39.20	82.19	39.72
N02	87.98	39.20	56.77	34.18
N03	80.20	39.20	48.41	28.68
N34E	112.27	39.45	119.07	73.94
N33E	108.07	39.37	106.17	65.49
N32E	104.40	39.37	93.29	57.05
N34W	107.85	38.03	109.43	76.39
N33W	114.90	39.53	106.12	65.44
N32W	108.40	39.53	93.24	57.01
S01	93.90	39.37	69.21	41.42
S02	91.90	39.28	60.28	35.55
S03	95.07	39.28	51.33	29.67
S34E	106.85	39.37	115.56	72.11
S33E	105.07	39.20	102.88	63.75
S32E	103.77	39.20	90.23	55.46
S34W	112.02	39.37	115.55	72.11
S33W	107.52	39.45	102.88	63.77
S32W	106.52	39.37	90.21	55.42

1 ft = 0.305 m.

CHAPTER 4. PHASE 1 INVESTIGATION

TESTING

Phase 1 testing of the stay cables on the Leonard P. Zakim Bunker Hill Bridge was conducted in May 2001, before the installation of dampers or crossties on the cable. Measurements were taken on the three longest stays in each of the six fans of cables. Testing started on the south tower by first measuring the single row of side-span cables, then measuring the two sets of parallel east–west oriented main-span cables. This testing was followed in reverse order for the cables on the north tower. Figure 22 shows the arrangement of cables tested in phase 1.

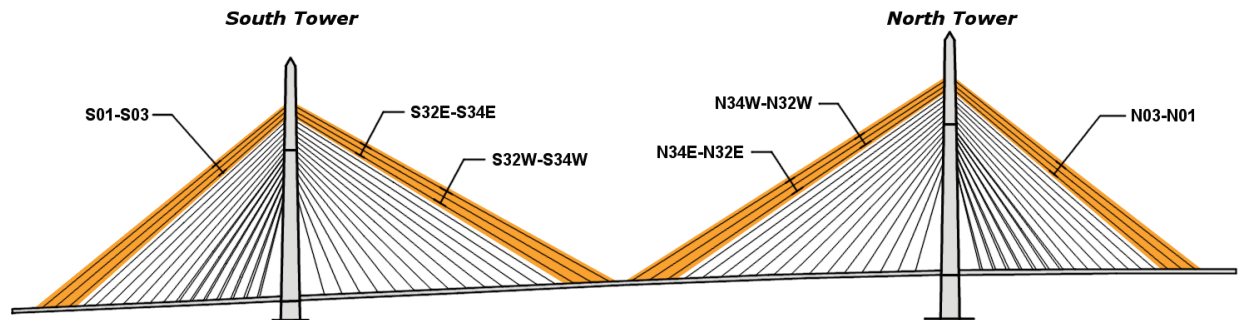

Source: FHWA.

Figure 22. Illustration. Arrangement of cables tested.

The testing occurred at a stage in construction where the deck spans were fully erected and supported by the stays but not fully connected at the center point of the main span. At the center connection, the edge girders were in place, along with some floor beams and some lower framing, but two concrete deck sections were not yet installed. In addition, although the center barriers were mostly completed, the outer barriers were not fully installed, which lessened the dead load. The weather during the week of testing was cold and overcast, with periods of rain and wind.

ANALYSIS

Frequency Content

To determine the fundamental mode frequencies for each cable, an estimated power spectral density (PSD) analysis was performed on the time–history series for each individual run. The density was calculated in MATLAB® using Welch’s method of averaged modified periodograms, which produces a one-sided density of frequency versus power per frequency, with an acquisition frequency of 100 Hz.⁽¹⁷⁾ The Welch function divides the input into eight segments with 50-percent overlap and with each segment subjected to a Hamming window function. The average of the periodograms determines the PSD estimate. For these cable vibrations, the frequencies of interest are extremely low (i.e., in the single-digit Hz range). Appropriately, density was graphed from 0 to 10 Hz, which contained the first 8 to 10 fundamental frequencies. Figure 23 shows a sample plot of the Welch spectral density plot.

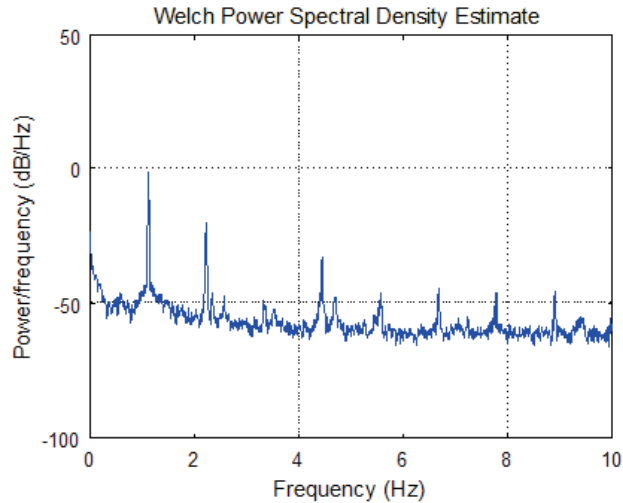

Source: FHWA.

Figure 23. Graph. Phase 1 spectral density plot of cable S02.

A cursor was placed on the plot and dragged along the points to determine the local maxima that corresponded to the natural frequencies. The frequencies were found with an accuracy of three decimal places for the first mode and two decimal places for the higher modes. The quality of the spectral density plots varied among the different runs. Some runs produced clear plots in which each natural frequency could easily be recorded up to the 9th or 10th mode. Other plots were harder to interpret. Sometimes the higher frequencies would lack distinct peaks, and other times the energy would fall under a wider curve with multiple peaks. When multiple peaks occurred, researchers used engineering judgment to determine which peaks were acceptable.

A table of the fundamental frequencies up to the seventh mode, if possible, was compiled for each time series for both accelerometer boxes (appendix A, table 8). The frequencies were usually equivalent between the two boxes and across the separate runs for each individual cable, but they occasionally varied by a small percentage. At times, researchers used a judgment call when determining the average natural frequency for a cable if it varied throughout the runs. If there were only a few outliers, the statistical mode was considered the average, but if there was greater variance among the runs, then the actual mean was calculated.

Damping Analysis

Once the fundamental frequencies were obtained for the first two modes, the damping ratios could then be calculated from the decay of the cable vibrations. Since the time–history for each run is the complex combination of numerous modes of vibration, a bandpass filter was used to isolate the decay associated with each mode. The passband frequencies were determined from the spectral density plot, with researchers choosing frequencies that closely encompassed the entire energy peak for the desired mode. A fourth-order elliptic filter was used on the signal twice to completely suppress the unwanted noise outside the band and effectively preserve the signal within the cutoff frequencies. An example of the elliptic filter’s effect on the spectral density plot of a data series is shown in figure 24.

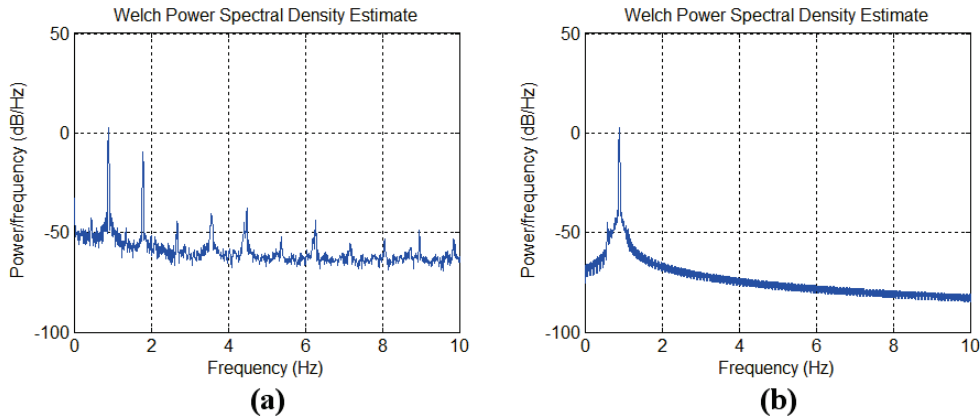

Source: FHWA.

Figure 24. Graph. Effect of the bandpass filter on spectral density (a) before and (b) after.

Once the bandpass filter had been applied, the time series resembled a more consistent logarithmic decay. A time filter was also established to eliminate the data associated with the manual excitation at the beginning of the run and the random excitations prevalent after the decay had subsided. Figure 25 shows a comparison of the time series before and after the bandpass and time filters were applied.

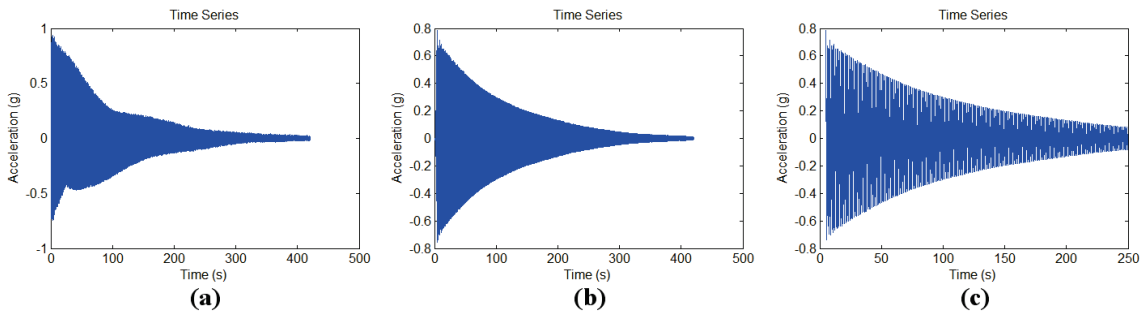

Source: FHWA.

Figure 25. Graph. Phase 1 plots comparing (a) original, (b) bandpass-filtered, and (c) truncated time series.

After the logarithmic decay curve was revealed, the damping ratio could then be extracted using the equation in figure 9. Software created in MATLAB was used to mark both the positive and negative peaks along the sinusoidal curve and then take the natural log of the peaks.⁽¹⁷⁾ Since damping was found from the ratio between two distinct, consecutive peaks, and that ratio varies throughout the run as the peaks vary, a regression line was fitted to the data to minimize random errors. An average damping ratio was then calculated from this best-fit line. A closeup of the software capturing the peaks from phase 1 testing of cable N33W, run 5, and the resulting regression line are shown in figure 26 through figure 29.

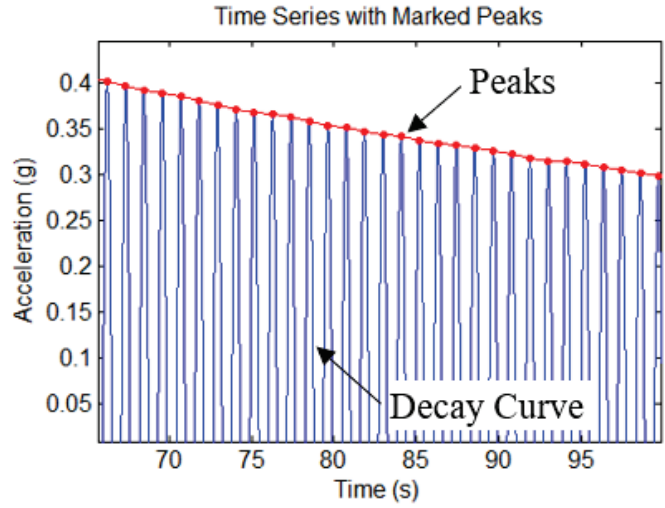

Source: FHWA.

Figure 26. Graph. Marked peaks of the decay curve.

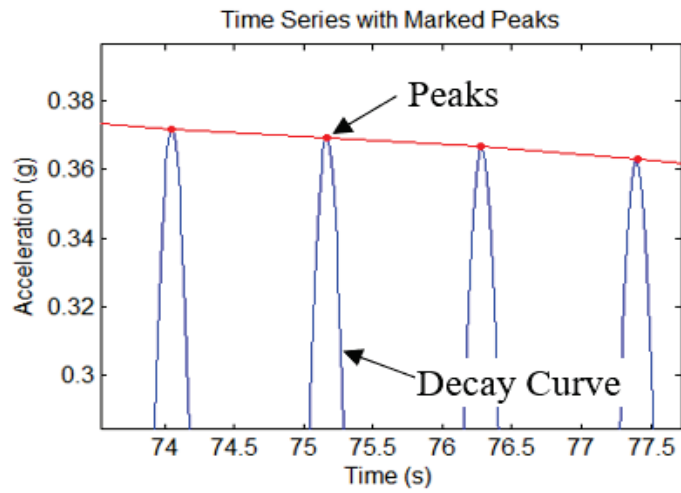

Source: FHWA.

Figure 27. Graph. Closer view of the marked peaks.

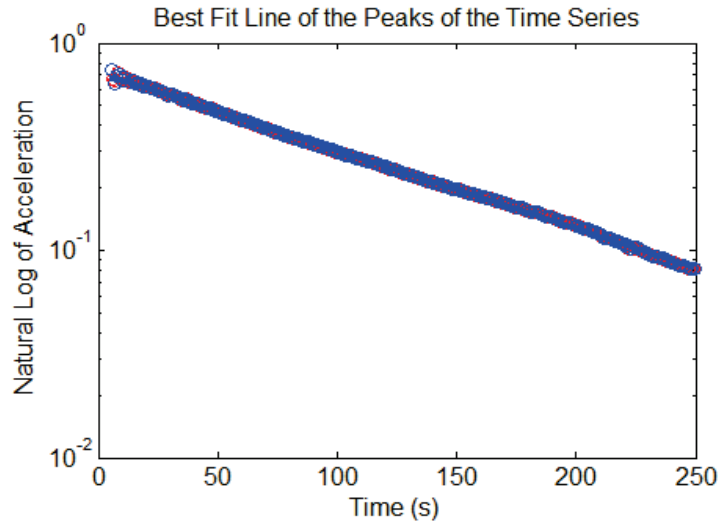

Source: FHWA.

Figure 28. Graph. Best-fit line of the natural log of the peaks.

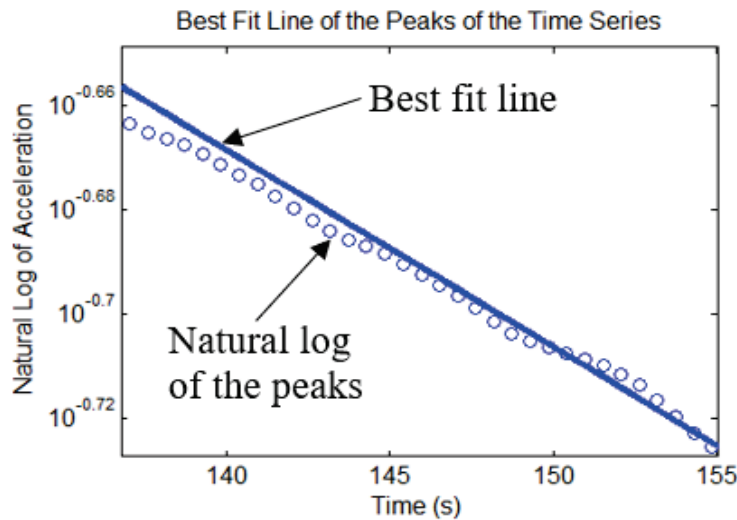

Source: FHWA.

Figure 29. Graph. Closer view of a 20-s interval of the best-fit line of the peaks.

To determine the effectiveness of the best-fit line, the correlation between the regression line and the actual peak data points was noted. In general, the correlation throughout the runs was extremely high, usually averaging more than 0.995 for the first mode. In most cables, the average correlation was even higher, averaging between 0.997 and 0.999. The second mode of damping did not have as strong a correlation in the decay curves as the first mode, and three cables showed no clear logarithmic decay at all in the second mode.

This correlation was also important because it helped determine the length of the sample. Researchers chose the longest sample length possible before ambient vibrations dominated the signal. The best-fit line and correlation numbers helped determine when the damping ended and the logarithmic decay assumption was no longer valid. The length of the decay curve varied

among the runs, with the second frequency mode experiencing greater variability than the first. While the first frequency mode generally averaged around 100 to 270 s, the second frequency mode varied between 17 to 150 s.

After the best-fit line was established, the damping ratio could be identified for each cable. The number of runs performed for each cable varied between five and eight, with an additional run dedicated to a baseline sample. Due to the small number of available sample datasets for each cable, and the fact that the population mean and variance were both unknown, the Student's *t*-test was used to find a 90-percent confidence interval on the mean.⁽¹⁸⁾ This statistical process was performed for every cable for both the first and second modes, and the graphs in figure 30 through figure 33 illustrate the results. These results are shown by cable grouping from each tower, north and south. Table 2 contains a summary of the damping ratio, correlation, and frequencies for each cable. If a cable is missing a plot point or a value from the table, it means that a value could not be extracted from the data.

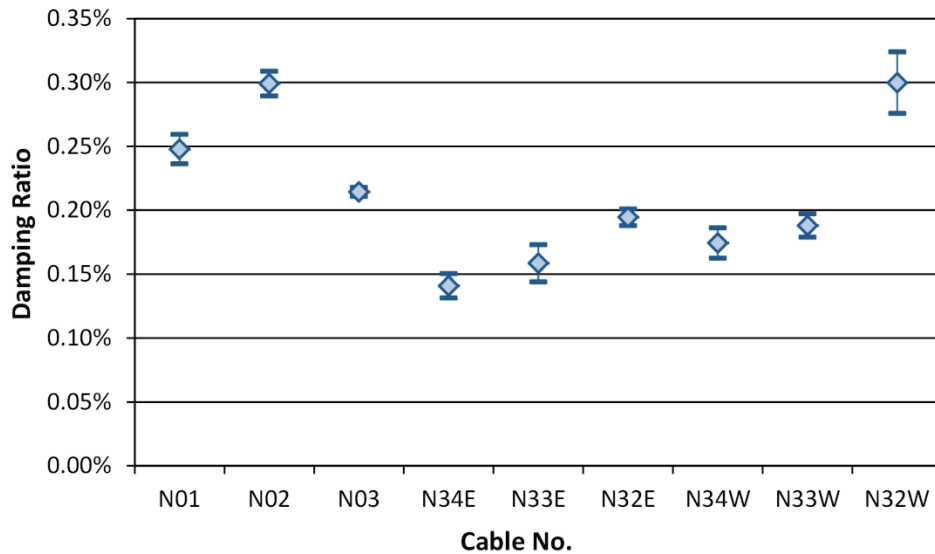

Source: FHWA.

Figure 30. Graph. Phase 1: first mode with 90-percent confidence interval on the mean for north-tower cables.

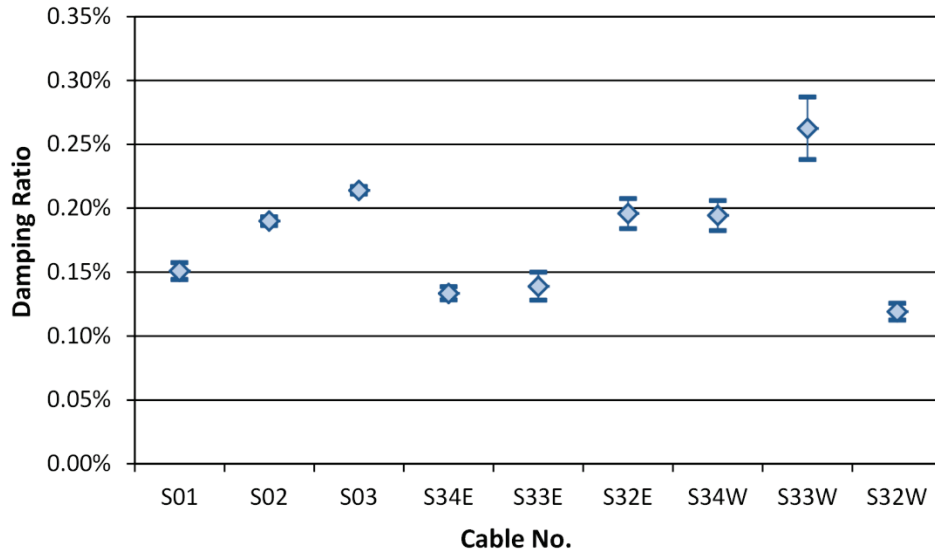

Source: FHWA.

Figure 31. Graph. Phase 1: first mode with 90-percent confidence interval on the mean for south-tower cables.

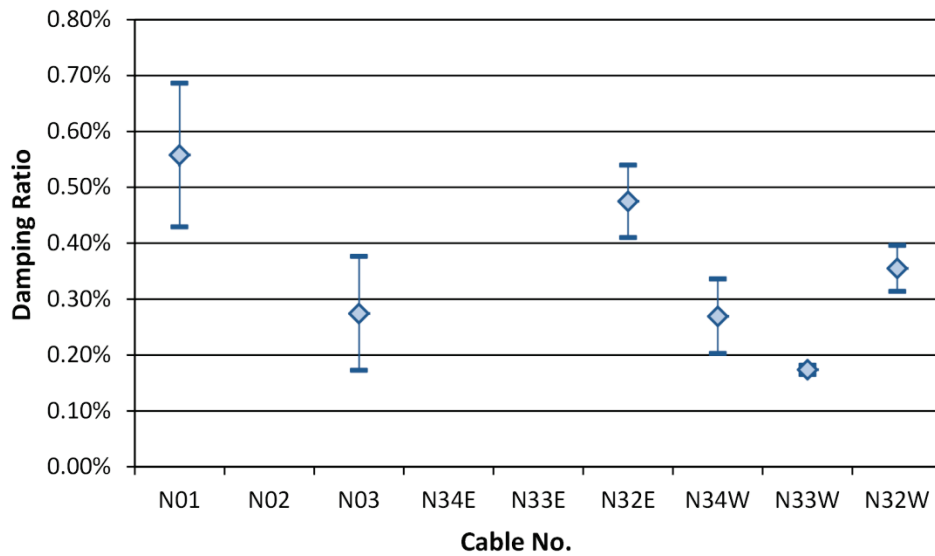

Source: FHWA.

Figure 32. Graph. Phase 1: second mode with 90-percent confidence interval on the mean for north-tower cables.

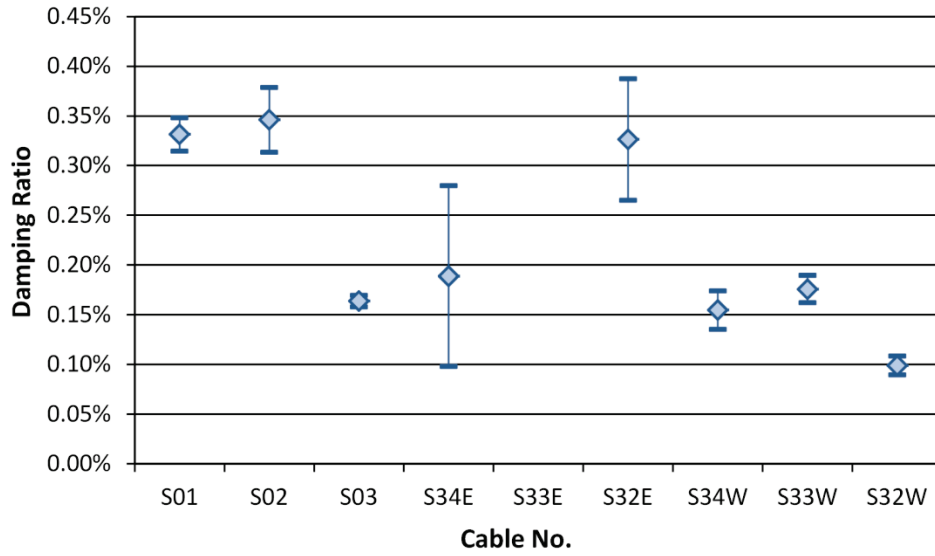

Source: FHWA.

Figure 33. Graph. Phase 1: second mode with 90-percent confidence interval on the mean for south-tower cables.

Table 2. Phase 1 summary of results.

Cable Number	First Mode			Second Mode		
	Average Damping Ratio (Percent)	Correlation	Average Length of Time Sample (s)	Average Damping Ratio (Percent)	Correlation	Average Length of Time Sample (s)
N01	0.248	0.9985	107.9	0.558	0.9976	17.8
N02	0.299	0.9990	92.2	—	—	—
N03	0.214	0.9977	143.8	0.274	0.9928	51.3
N34E	0.141	0.9950	170.0	—	—	—
N33E	0.158	0.9992	235.0	—	—	—
N32E	0.194	0.9984	251.2	0.474	0.9956	43.0
N34W	0.174	0.9990	218.3	0.269	0.9911	67.5
N33W	0.188	0.9993	272.5	0.173	0.9971	139.2
N32W	0.300	0.9983	153.3	0.355	0.9917	57.7
S01	0.151	0.9986	231.5	0.331	0.9908	48.0
S02	0.190	0.9982	217.9	0.346	0.9905	40.4
S03	0.214	0.9994	175.8	0.164	0.9837	81.3
S34E	0.133	0.9989	297.8	0.189	0.9973	125.0
S33E	0.139	0.9991	262.9	—	—	—
S32E	0.196	0.9981	205.0	0.326	0.9837	51.3
S34W	0.194	0.9975	202.3	0.155	0.9962	113.1
S33W	0.262	0.9978	161.7	0.176	0.9843	101.0
S32W	0.119	0.9985	277.1	0.099	0.9898	158.3

—No data available.

DISCUSSION

Frequency Content

The frequency trends obtained from the PSDs generally matched what would be expected. The fundamental frequencies increased as the length of the cable in each fan decreased. The longest cables supporting the main span of the bridge exhibited lower fundamental frequencies than their side-span counterparts. Results for east and west fans of cables on the main span were similar but varied slightly because their cable properties are different: the cables on the east span are heavier and designed to support the load of two additional cantilevered lanes. Figure 34 shows first-mode frequencies obtained from testing.

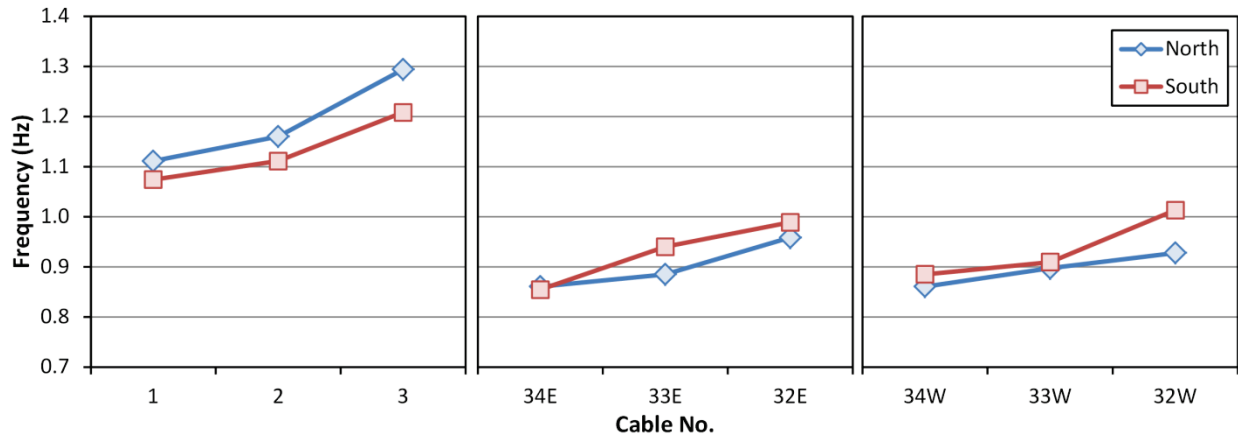

Source: FHWA.

Figure 34. Graph. First-mode frequencies from phase 1 testing for (left to right) side-span, main-span east, and main-span west cables.

Frequencies measured between the two accelerometers were usually in agreement within 1 percent, although they would occasionally vary by up to 5 percent. Similarly, the frequency measurements among the various runs for each cable were mainly consistent, with the maximum difference for any mode frequency for a cable in the range of 4 to 5 percent.

The data from most cables produced clear spectral densities, easily allowing the first seven harmonic frequencies to be recorded in at least one of each cable’s experimental runs; however, during phase 1 testing, four cables exhibited weak energy in the spectrum surrounding the third-mode frequency, which prevented clear peak data from being recorded. Additionally, two other cables exhibited weak densities in the higher modes.

A wiring error during setup resulted in accelerometer box 2 not recording data from the z-axis channel for the first six cables tested during phase 1. Frequencies were still successfully measured from the x-axis channel, but the spectrums were not as clear.

Although the cables tested in phase 1 produced varying qualities of spectral densities, all contained the most power within the first two modes of vibration. Frequency plots for the first seven modes of phase 1 testing can be found in appendix B.

Damping Ratios

The damping ratios calculated from phase 1 testing were consistent, with strong correlations for first-mode frequencies. All the confidence bands on the mean were small, indicating consistent decay for each cable across all runs. For second-mode damping ratios, however, there was much more variability, and some cables did not have measurable decay at all.

There was no correlation between damping ratio and cable length or other material properties. All but one of the mean damping ratios for the first mode were between 0.10 and 0.30 percent. For the second-mode damping ratios, the range increased to between 0.10 and 0.56 percent. All mean damping ratios calculated in phase 1 were under 0.56 percent.

Scruton Number Analysis

Another widely used mass-damping parameter indicating the level of cable damping with respect to vibration mitigation is the Scruton number, Sc , defined in figure 35:⁽¹⁹⁾

$$Sc = \frac{\zeta m}{\rho D^2}$$

Figure 35. Equation. Scruton number.

Where:

ζ = first-mode damping ratio.

m = mass density per unit length of cable.

ρ = mass density of air.

D = diameter of the cable pipe.

The Scruton number is frequently used in developing a criterion for controlling rain- and wind-induced vibration of stay cables. For example, based on Irwin's suggestion, the Post-Tensioning Institute's committee on cable-stayed bridges has suggested that rain- and wind-induced vibrations of stay cables can be avoided if the Scruton number is kept at a value of 10 or more.^(20,1) Additionally, a reduced Scruton number of 5 has been suggested if the cable has an aerodynamic surface treatment.⁽²⁾

Plugging the measured damping values presented in table 2 and the corresponding cable properties (found in appendix D, table 29) into the equation in figure 35 returned the Scruton numbers shown in table 3. The Scruton numbers ranged from 1.1 to 3.8, far lower than the desired value of 10, indicating that the cable system under consideration was potentially vulnerable to rain-wind-induced (and perhaps wind-induced) vibrations. The cables would still be vulnerable if a reduced Scruton number was used to account for the aerodynamic surface treatment. Based on these results, it was confirmed that appropriate vibration-mitigation measures, such as dampers or crossties, had to be incorporated into the cable system.

Table 3. Phase 1 Scruton number.

Cable Number	Scruton Number
N01	3.2
N02	3.8
N03	2.7
N34E	1.4
N33E	1.5
N32E	1.8
N34W	1.6
N33W	1.7
N32W	2.7
S01	2.2
S02	2.7
S03	3.0
S34E	1.4
S33E	1.5
S32E	2.0
S34W	2.0
S33W	2.6
S32W	1.1

CHAPTER 5. PHASE 2 INVESTIGATION

TESTING

Phase 2 testing of the stay cables on the Leonard P. Zakim Bunker Hill Bridge was conducted in August 2001 after the installation of IED+ dampers but before the installation of crossties. The same sets of cables were tested as in phase 1 (i.e., the three longest in each fan), although in a slightly different order (figure 22). The cables on the north side span were tested first, followed by both sets of cables on the east main span, then the west main span, concluding with the south side span.

Construction was still ongoing during the second phase of testing. By this point, the concrete deck had been completed, and the main span was fully connected. Median barriers had been fully installed, and placement of the concrete deck overlay was in process, meaning concrete trucks were on the bridge producing some unwanted vibrations. Weather was generally favorable, although some days were windy.

ANALYSIS

Frequency Content

As in phase 1, spectral density analyses were used to determine the fundamental mode frequencies for each cable tested during phase 2. Once again, the spectral densities were calculated in MATLAB using Welch's averaged modified periodogram method and plotted on a scale from 0 to 10 Hz.⁽¹⁷⁾ The mode frequencies were determined by tracing the peaks of the density plot. Compared to phase 1 results, the data from phase 2 produced weaker spectrums that usually allowed the first five frequencies to be recorded, but higher frequencies could not always be accurately identified among the noise. Figure 36 shows an example of the spectral density plot for cable N01. The complete table of frequency values for the testing performed in phase 2 can be found in appendix A, table 10.

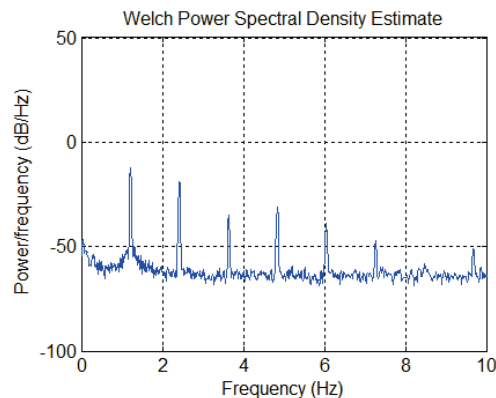

Source: FHWA.

Figure 36. Graph. Phase 2 spectral density plot of cable N01.

Damping Analysis

The damping analysis for phase 2 testing utilized the same initial procedures outlined previously for phase 1. Figure 37 shows the effect of the bandpass and time filter on cable N01.

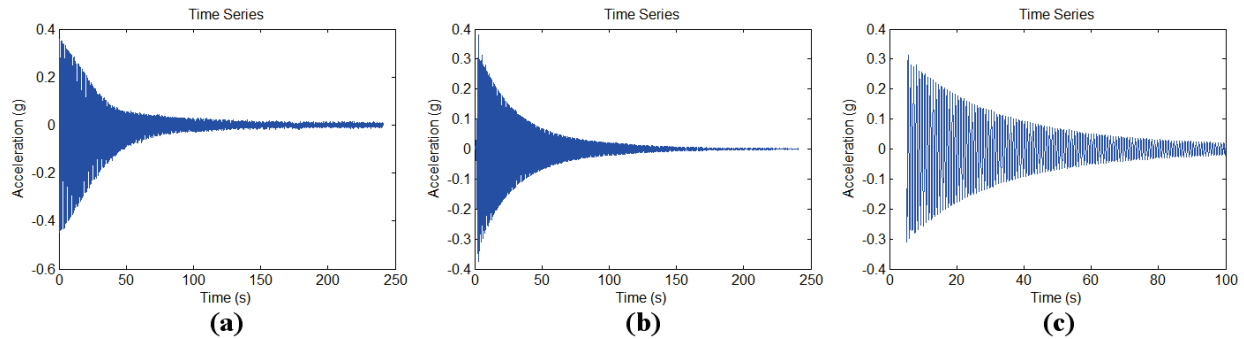

Source: FHWA.

Figure 37. Graph. Phase 2 plots comparing (a) original, (b) bandpass-filtered, and (c) truncated time series.

Once again, best-fit lines of the positive and negative peaks were used to determine the appropriate length of the decay curve. The correlation between the best-fit line and the peaks was maintained at a value greater than 0.990 by adjusting the length of the sample of the decay curve used, although a few cables averaged slightly less than that value for second-mode damping. The length of the decay curves ranged between 65 and 250 s for testing performed on the first mode and between 28 and 80 s for testing performed on the second mode.

After best-fit lines were established for each cable run, the damping ratios could again be calculated and then averaged for each individual cable. During phase 2 testing, eight runs were usually performed for each cable, but cable N03 only had five runs. There were also a few cases where invalid data forced researchers to discard runs. Again, the Student's t -test was used to find the 90-percent confidence level on the mean of the damping ratio for each cable for both the first and second modes. Graphs of the results are shown in figure 38 through figure 41, while table 4 contains a summary of the damping ratios, correlations, and frequencies for each cable. These figures and table show the averaged data from the two boxes.

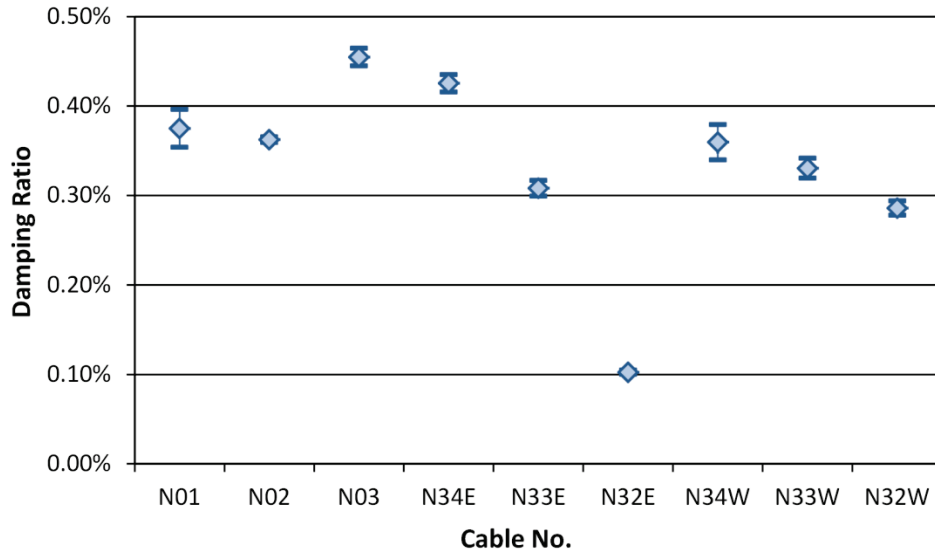

Source: FHWA.

Figure 38. Graph. Phase 2: first mode with 90-percent confidence interval on the mean for north-tower cables.

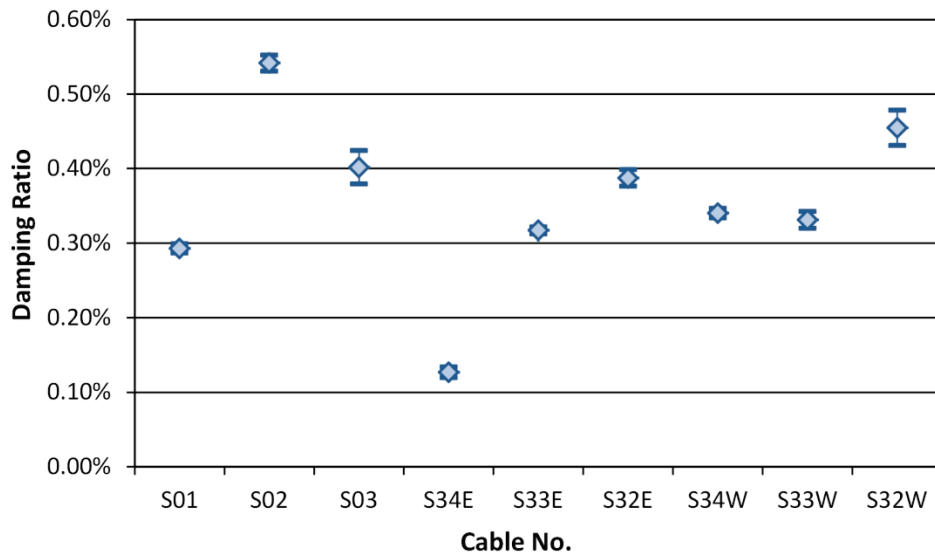

Source: FHWA.

Figure 39. Graph. Phase 2: first mode with 90-percent confidence interval on the mean for south-tower cables.

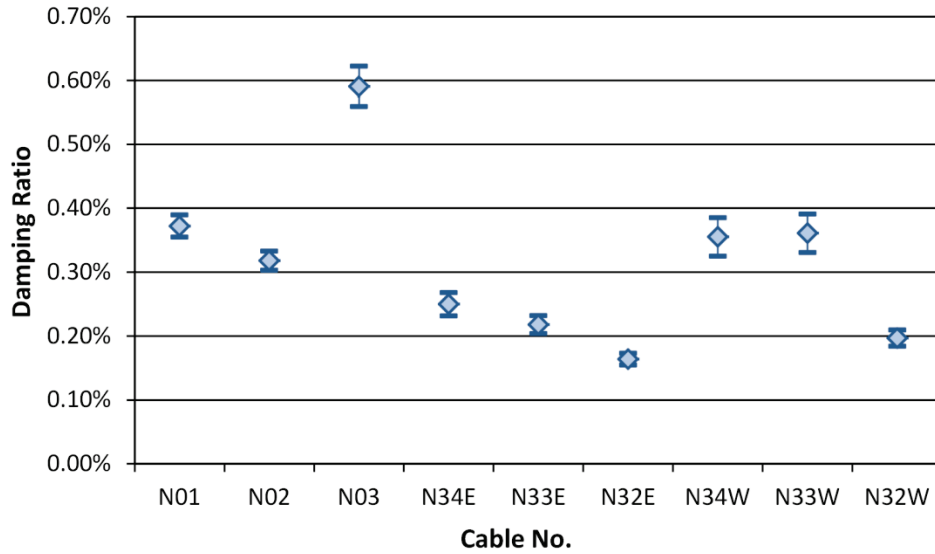

Source: FHWA.

Figure 40. Graph. Phase 2: second mode with 90-percent confidence interval on the mean for north-tower cables.

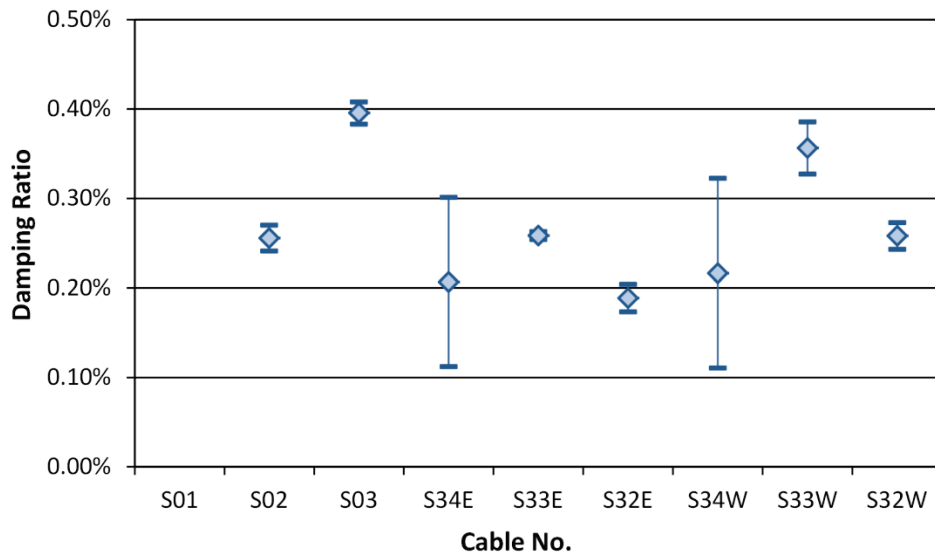

Source: FHWA.

Figure 41. Graph. Phase 2: second mode with 90-percent confidence interval on the mean for south-tower cables.

Table 4. Phase 2 summary of results data.

Cable Number	First Mode			Second Mode		
	Average Damping Ratio (Percent)	Correlation	Average Length of Time Sample (s)	Average Damping Ratio (Percent)	Correlation	Average Length of Time Sample (s)
N01	0.375	0.9967	92.8	0.372	0.9938	39.7
N02	0.362	0.9993	94.4	0.318	0.9871	46.9
N03	0.455	0.9982	68.0	0.591	0.9925	28.5
N34E	0.425	0.9982	93.8	0.250	0.9933	55.6
N33E	0.308	0.9991	135.6	0.218	0.9973	75.3
N32E	0.102	0.9981	266.9	0.164	0.9943	65.0
N34W	0.360	0.9989	117.5	0.355	0.9973	60.6
N33W	0.330	0.9990	117.2	0.361	0.9970	53.2
N32W	0.286	0.9975	93.8	0.197	0.9938	64.4
S01	0.293	0.9985	134.4	—	—	—
S02	0.542	0.9993	77.1	0.255	0.9912	55.7
S03	0.402	0.9982	84.4	0.395	0.9967	53.0
S34E	0.127	0.9975	186.9	0.206	0.9917	62.5
S33E	0.317	0.9989	128.8	0.258	0.9981	66.9
S32E	0.387	0.9990	100.0	0.189	0.9777	61.7
S34W	0.340	0.9989	105.8	0.216	0.9798	82.5
S33W	0.331	0.9991	117.5	0.356	0.9971	55.7
S32W	0.455	0.9984	87.1	0.258	0.9979	68.6

—No data available.

DISCUSSION

Frequency Content

Phase 2 testing generally produced weaker spectrums that made it difficult to identify frequencies higher than the first five modes. Usually there was at least one run among the five to eight runs conducted for each cable with enough energy to produce peaks for the higher frequencies, but that did not happen for each cable. First-mode frequencies obtained from testing both side- and main-span cables are shown in figure 42.

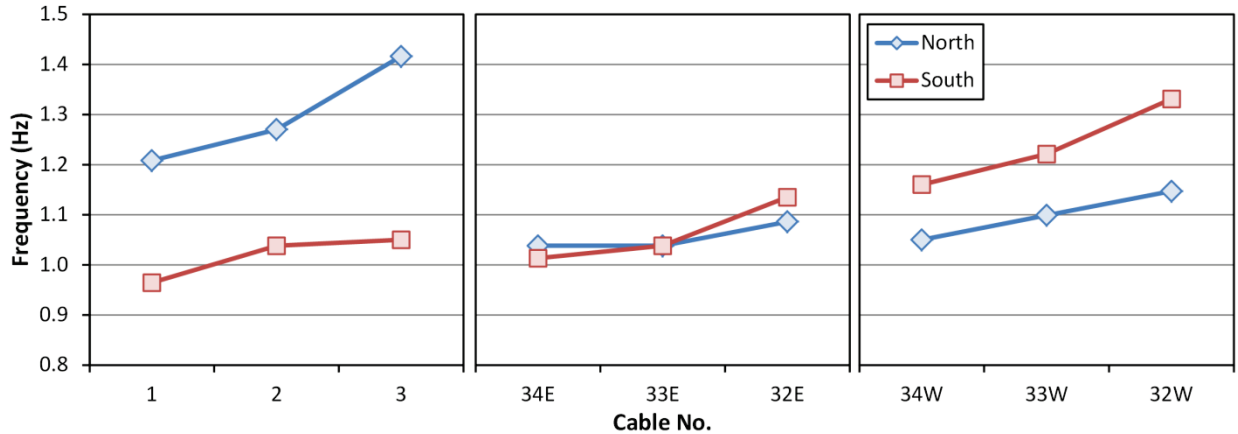

Source: FHWA.

Figure 42. Graph. First-mode frequencies from phase 2 testing for (left to right) side-span, main-span east, and main-span west cables.

The frequencies measured between the two accelerometers were once again in agreement, with only three instances where the pair varied by more than 1 percent. Similarly, the frequency measurements among the various runs for each cable were mainly consistent, with the maximum difference for any mode frequency for a cable around 2 to 3 percent.

When viewing the spectral density plots, it is apparent that the most power is usually associated with the first mode of vibration, with the second mode showing strong peaks as well.

Damping Ratios

Similar to phase 1, the damping ratios calculated during phase 2 testing were consistent for each cable, with strong correlations and small confidence intervals on the mean for first-mode frequencies. Once again, there was more variability for the measurements obtained for the second mode, including one cable where a damping ratio could not be calculated at all. Second-mode calculations had poorer correlation and wider confidence intervals than the first mode.

Again, there did not appear to be any correlation between damping ratio and material properties or cable length. First-mode damping ratios varied between 0.10 and 0.54 percent, while second-mode damping ratios varied from 0.16 to 0.59 percent.

The installation of the IED+ resulted in a modest increase in damping ratios on almost all the tested cables compared to phase 1, which is further explored in chapter 7. Additionally, the average length of the decay curve in phase 2 shortened by an average of 87 s for the first mode.

Scruton Number Analysis

Damping values obtained during phase 2 testing were entered into the equation in figure 35 to calculate the resulting Scruton number. The results are shown in table 5. Although four of the cables had Scruton numbers greater than the desired reduced limit of 5 for cables with aerodynamic surface treatments, the rest of the tested cables had values between 2 and 5. Based

on these results, it was confirmed that an appropriate vibration mitigation measure, such as crossies, had to be incorporated into the cable system.

Table 5. Phase 2 Scruton number.

Cable Number	Scruton Number
N01	4.9
N02	4.6
N03	5.6
N34E	4.1
N33E	2.9
N32E	1.0
N34W	3.3
N33W	3.1
N32W	2.5
S01	4.3
S02	7.7
S03	5.6
S34E	1.4
S33E	3.4
S32E	4.0
S34W	3.5
S33W	3.3
S32W	4.4

CHAPTER 6. PHASE 3 INVESTIGATION

TESTING

Phase 3 testing of the cable stays on the Leonard P. Zakim Bunker Hill Bridge was conducted in September 2001 after the installation of both dampers and a line of crossties. As in the previous two phases, the three longest cables were again tested in each fan, as shown in figure 43. This illustration is nearly identical to figure 22, but the location of the crosstie on each fan is also shown. Testing began on the main span, first with the west cables, then the east cables, before moving to the south side-span and then wrapping up with the north side-span cables. The accelerometer boxes and pull rope were always attached at a position below the level of the crossties for each tested cable.

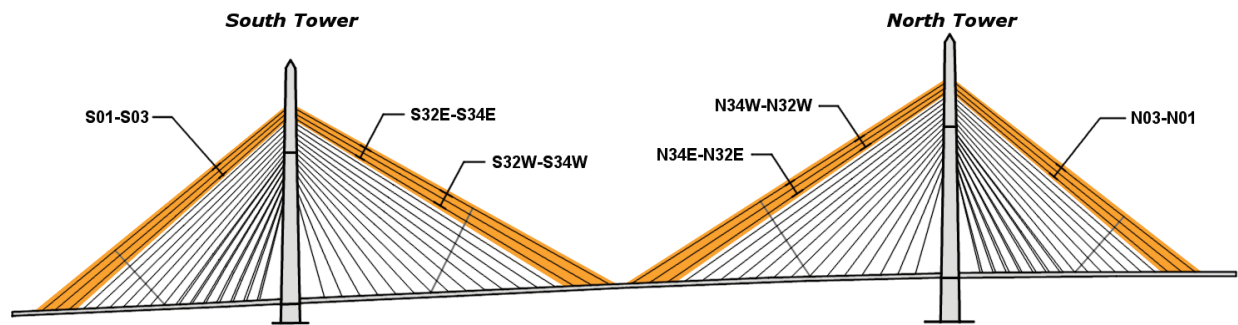

Source: FHWA.

Figure 43. Illustration. Arrangement of cables tested in phase 3.

At this point during construction, most of the dead load had been completed, but there were still concrete trucks on the deck, which produced some unwanted extra vibrations.

ANALYSIS

Frequency Content

As in the first two phases, spectral density analyses were used to determine the fundamental mode frequencies for each cable tested during phase 3. The spectral densities were again calculated in MATLAB using Welch's averaged modified periodogram method and plotted on a scale from 0 to 10 Hz.⁽¹⁷⁾ The mode frequencies were determined by tracing the peaks of the density plot. Due to the single line of crossties now connecting the cables—thus creating a multiple DOF network of cables—the data from phase 3 produced complex spectrums containing both local and global modes. An example of the spectral density plot is shown in figure 44 for cable S33W, although the horizontal scale has been expanded to 15 Hz to show more frequency peaks. The full table of frequency values for the testing performed in phase 3 can be found in appendix A, table 12.

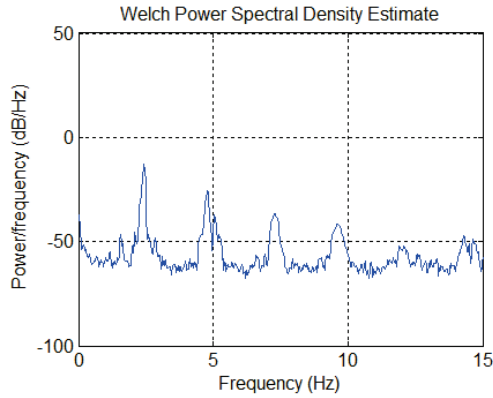

Source: FHWA.

Figure 44. Graph. Phase 3 spectral density plot of cable S33W.

Damping Analysis

The damping analysis for phase 3 testing used the same initial procedures outlined earlier for phases 1 and 2. Figure 45 shows the effect of the bandpass and time filter on cable S33W, which is attached to a single line of crosssties.

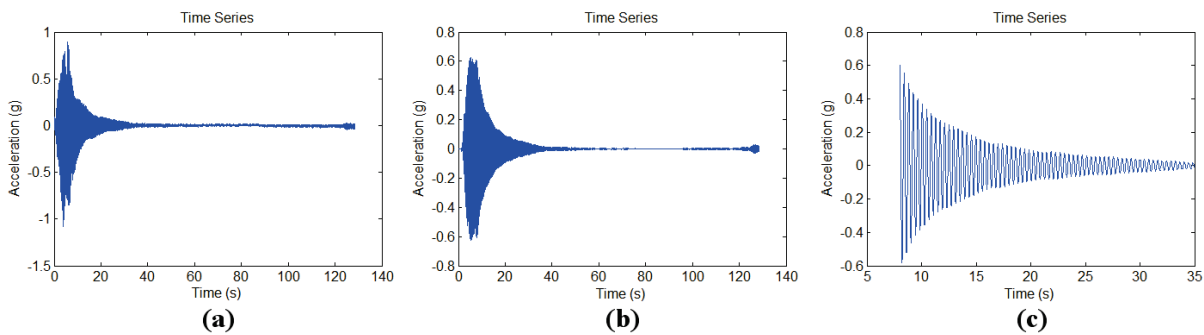

Source: FHWA.

Figure 45. Graph. Phase 3 plots comparing (a) original, (b) bandpass-filtered, and (c) truncated time series.

Once again, best-fit lines of the positive and negative peaks were used to determine the appropriate length of the decay curve. In the previous phases, the goal was to maintain the correlation between the best-fit line and the peaks at a value greater than 0.990; however, with the introduction of crosssties, the decay data became extremely difficult to work with. In only a few cases could correlations be kept equal to or greater than the target value. For the first mode, only 8 out of 18 cables tested had correlations more than 0.990, and the second mode was even worse. For the second mode of testing, researchers were unable to establish any best-fit values for 12 of the cables, and 2 of the remaining 6 cables had correlations of less than 0.990. Among those cables for which researchers could establish best-fit lines, the length of the decay curves ranged between 11 and 35 s for testing performed on the first mode and between 7 and 24 s for testing performed on the second mode.

After best-fit lines were established for each cable run, the damping ratios could again be calculated and averaged for each individual cable. During phase 3 testing, the number of runs performed for each cable was either seven or eight, but there were many runs where the data did not produce a measurable decay curve and could not be included. Again, the Student's *t*-test was used to find the 90-percent confidence interval on the mean of the damping ratio for each cable for both the first and second modes. Graphs of the results are shown in figure 46 through figure 49, while table 6 contains a summary of the damping ratio, correlation, and frequencies for each cable. The figures and table show the averaged data from the two boxes. Plots that contain points with no data correspond to cables for which damping ratios could not be extracted for any of the runs.

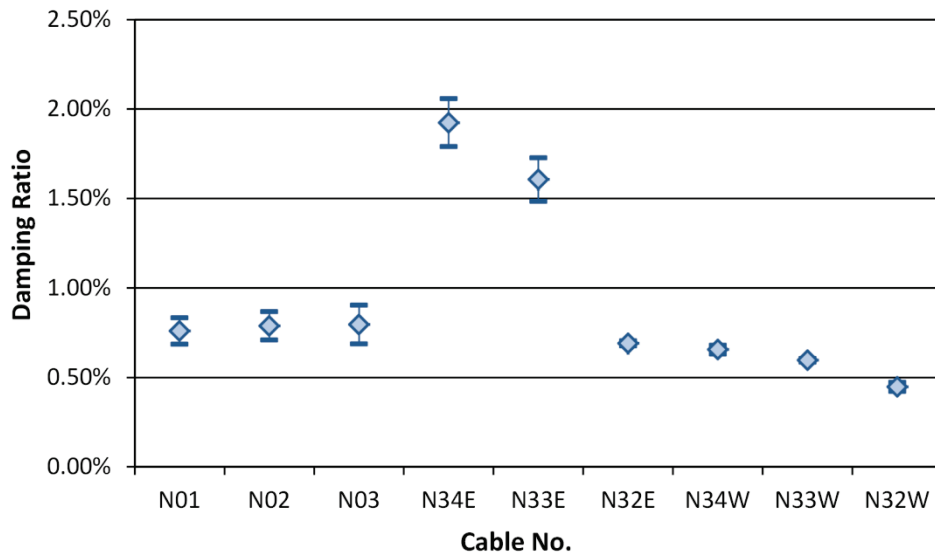

Source: FHWA.

Figure 46. Graph. Phase 3: first mode with 90-percent confidence interval on the mean for north-tower cables.

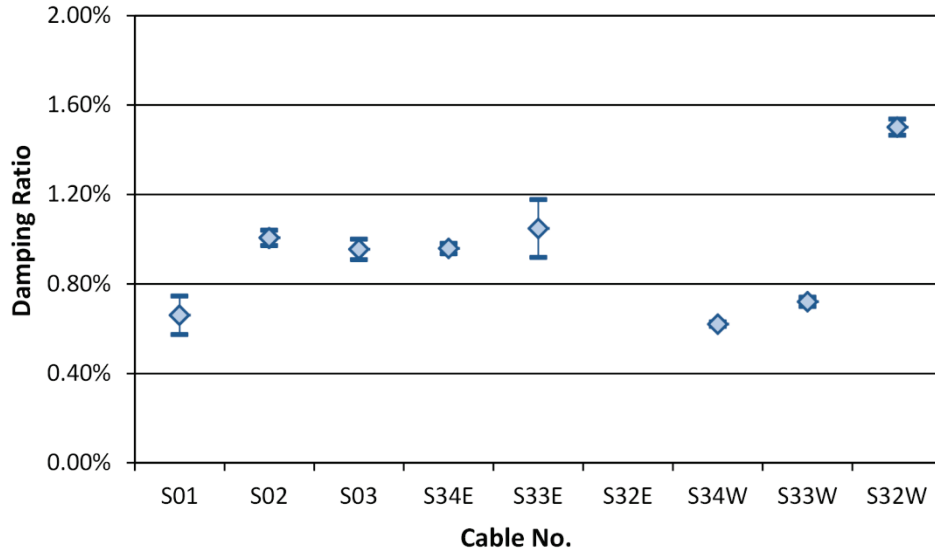

Source: FHWA.

Figure 47. Graph. Phase 3: first mode with 90-percent confidence interval on the mean for south-tower cables.

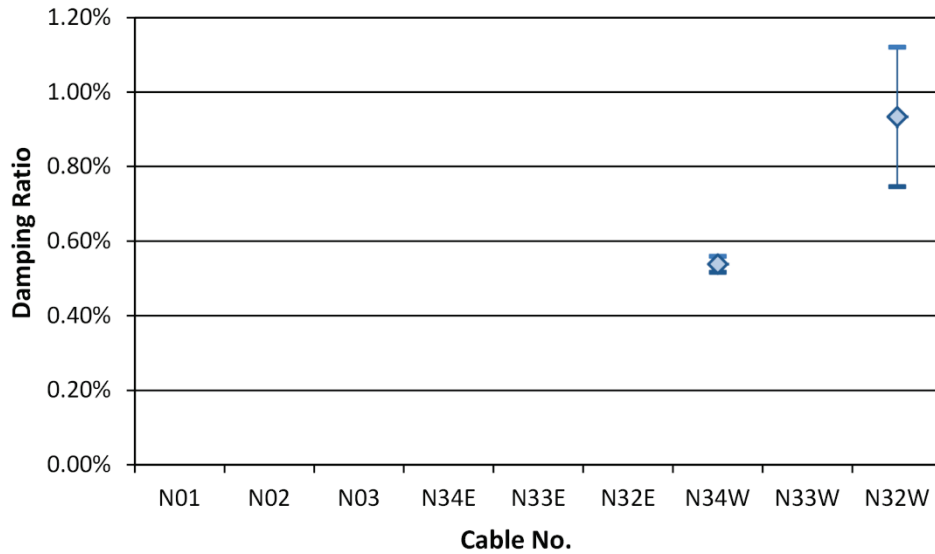

Source: FHWA.

Figure 48. Graph. Phase 3: second mode with 90-percent confidence interval on the mean for north-tower cables.

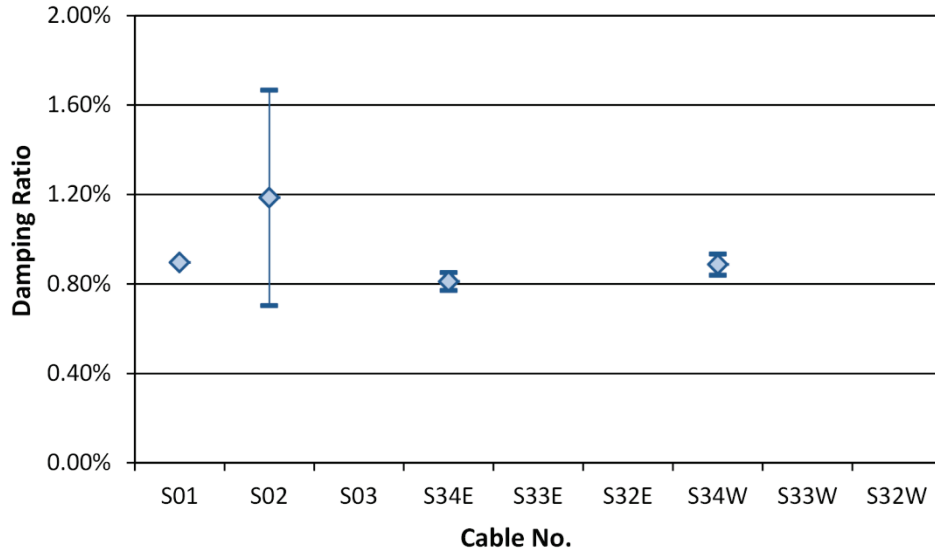

Source: FHWA.

Figure 49. Graph. Phase 3: second mode with 90-percent confidence interval on the mean for south-tower cables.

Table 6. Phase 3 summary of results data.

Cable Number	First Mode			Second Mode		
	Average Damping Ratio (Percent)	Correlation	Average Length of Time Sample (s)	Average Damping Ratio (Percent)	Correlation	Average Length of Time Sample (s)
N01	0.759	0.9914	18.5	—	—	—
N02	0.788	0.9774	13.2	—	—	—
N03	0.796	0.9250	16.0	—	—	—
N34E	1.923	0.9941	12.2	—	—	—
N33E	1.605	0.9830	11.3	—	—	—
N32E	0.691	0.9896	24.4	—	—	—
N34W	0.655	0.9940	34.2	0.537	0.9962	23.4
N33W	0.596	0.9935	33.6	—	—	—
N32W	0.447	0.9692	38.5	0.933	0.9934	9.0
S01	0.660	0.9736	21.6	0.895	0.9970	7.0
S02	1.005	0.9853	12.3	1.185	0.9904	6.0
S03	0.954	0.9973	12.5	—	—	—
S34E	0.957	0.9929	19.6	0.810	0.9872	11.5
S33E	1.047	0.9931	19.5	—	—	—
S32E	—	—	—	—	—	—
S34W	0.619	0.9957	34.7	0.886	0.9942	13.0

—No data available.

DISCUSSION

Frequency Content

Phase 3 testing produced erratic results during the frequency analysis. After the installation of a single line of crossties, the cables no longer operated as a simple taut string but rather as a complex network of cables where both global and local modes would affect vibrations. For some cables, frequencies were still easily determined from the PSD graphs, but other cables had extra peaks scattered throughout the spectrums, creating confusion about where to isolate the response to extract the decay curves. To alleviate some of the confusion, phase 3 data were analyzed a second time to calculate the spectral density for the section of time–history that corresponded directly to the decay. The goal was to ignore any vibrations related to the pull-cable excitation or ambient deck vibrations affecting the cable at the end of the run. The length of the decay curve could only be 20 to 30 s, while the entire run would last 200 to 300 s, resulting in long periods of ambient data being collected.

Analyzing the shorter time–history segment produced a coarser spectral density in which it was somewhat easier to identify notable peaks. Still, even with this method, it was not possible to extract peaks up to the seventh mode for some of the cables. For the cables supporting the side spans from both the north and south towers, it was particularly difficult to extract frequencies past the first mode. Many of these runs had a wide band of energy with scattered, jagged peaks, which were difficult to interpret. Figure 50 is a spectral density plot for cable N03 and shows the difficulty in identifying mode–frequency peaks. Compared to figure 44, there is no regular repeating pattern of peaks in the plot.

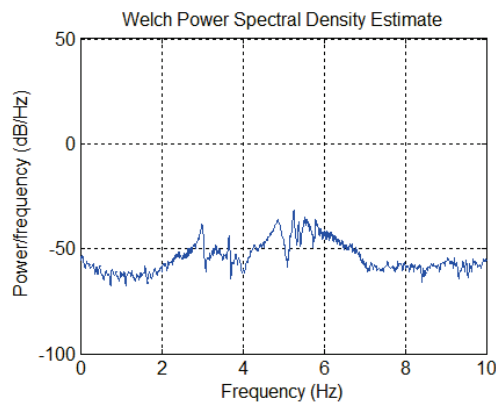

Source: FHWA.

Figure 50. Graph. Phase 3 spectral density plot for cable N03.

The first-mode frequencies for phase 3 for both north and south towers are plotted in figure 51. As mentioned earlier, the main-span cables produced better spectral density plots than the side-span cables because they were easier to excite, and the results are reflected in these plots with more consistent data.

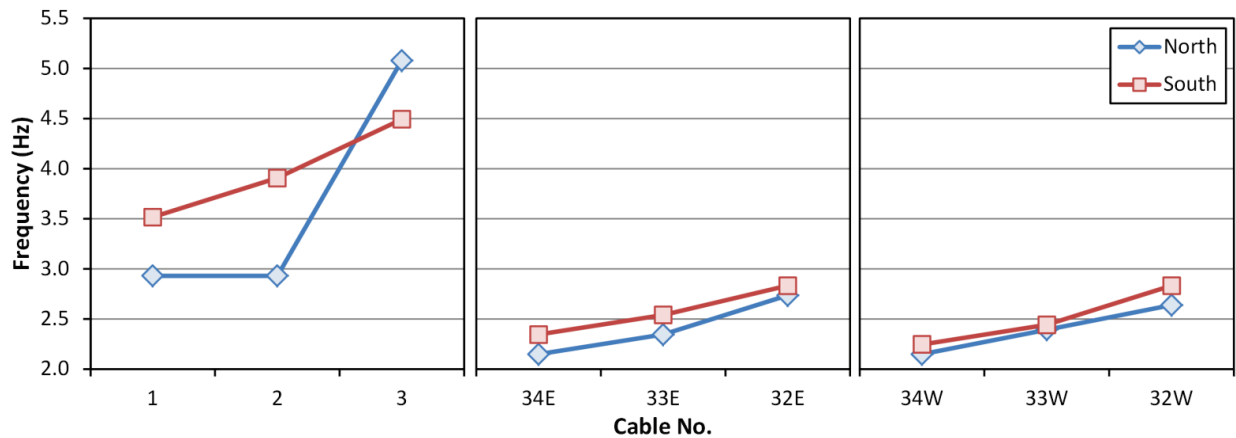

Source: FHWA.

Figure 51. Graph. First-mode frequencies from phase 3 testing for (left to right) side-span, main-span east, and main-span west cables.

The frequencies measured between the two accelerometers were usually in agreement, although in rare cases they would vary up to 2 or 3 percent. However, the frequency measurements among the various runs for each cable were not as consistent, with differences for any mode frequency for a cable ranging between 0 and 3 percent and, in several cases, between 10 and 30 percent. These discrepancies were due to two peaks being next to each other, and in different runs the peak containing the most energy would alternate.

Damping Ratios

As discussed in the frequency section immediately prior, the peaks from the spectral density plots for phase 3 testing were wider and contained more distributed energy than similar plots for phases 1 and 2 that contained energy concentrated in distinct peaks. These wider peaks resulted in greater difficulty identifying the boundary frequencies for the bandpass filter to use to isolate a damping curve for a specific mode.

In general, the damping ratios in the third phase were very short, especially compared to the first two phases. These shorter damping ratios meant both that it was much more difficult to introduce energy into the system and that it would dampen out faster. Some of the side-span cables were so difficult to excite that researchers often made multiple attempts to achieve notable vibrations per run, and when later analyzed, data did not show any logarithmic decay. Therefore, many cable entries in table 6 do not contain any data because those ratios could not be calculated. The inability to calculate damping ratios was especially prevalent for the second-mode.

When damping ratios were successfully extracted during phase 3, they did show higher damping than the previous two phases, with most cables greater than 0.5 percent and some cables even greater than 1 percent.

Scruton Number Analysis

Damping values that were successfully obtained during phase 3 testing were entered into the equation in figure 35 to calculate the resulting Scruton number. The results are shown in table 7.

Many of the cables have Scruton numbers greater than 10, and all but one have a Scruton number greater than 5, which is the reduced minimum value allowed for cables with aerodynamic surface treatments.

Table 7. Phase 3 Scruton numbers.

Cable Number	Scruton Number
N01	9.8
N02	10.1
N03	9.9
N34E	18.7
N33E	15.3
N32E	6.6
N34W	6.1
N33W	5.5
N32W	4.0
S01	9.6
S02	14.3
S03	13.4
S34E	10.3
S33E	11.1
S32E	—
S34W	6.4

—No data available.

CHAPTER 7. SUMMARY OF COMPARISONS

FREQUENCY

The frequencies obtained for similar cables experienced various levels of symmetry across the mirrored fans. The frequencies measured in the main span were generally close among all similar cables for the first and second phases, with the second phase values being slightly higher, most likely due to increased dead load as features such as barriers and the concrete overlay were completed. Phase 3 frequencies tended to be at least two times higher than phases 1 and 2, most likely due to the row of added cross-ties creating a shorter effective length of the cables. The cross-ties also created a global network of cables in which adjacent cables could interact and affect the frequency measurements. The side-span cables featured even higher frequencies in phase 3, and the north cables especially jumped quite erratically. Figure 52 shows a plot comparing the various first-mode frequencies for all cables across all phases.

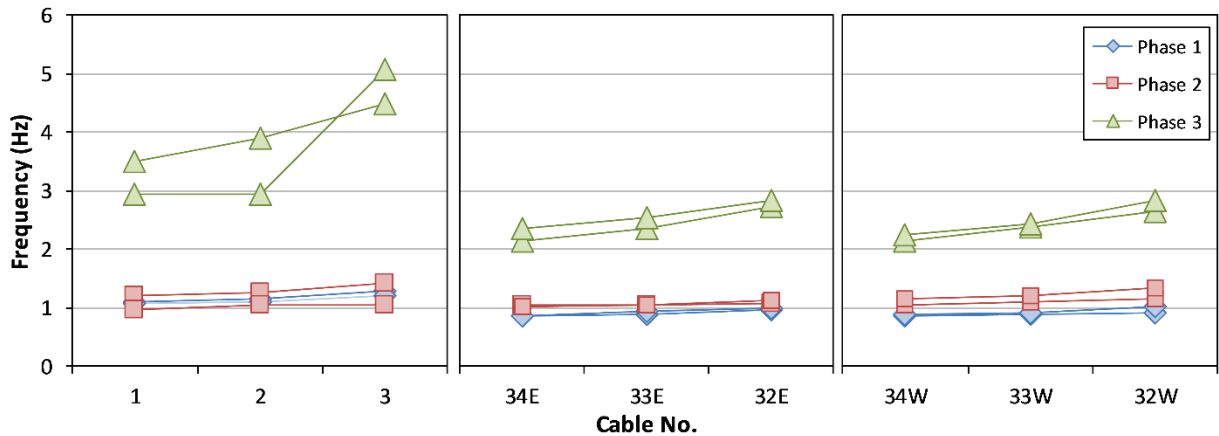

Source: FHWA.

Figure 52. Graph. Comparison of first-mode frequencies for all phases for (left to right) side-span, main-span east, and main-span west cables.

Figure 53 compares the second-mode frequency values. Like the first mode, the measured frequencies for the similar cables on the main span are all relatively close between the first two phases, while the third phase values increase by more than double due to cross-ties. The phase 3 side-span values increase by even more, although second-mode values could not be measured for cables N01 or N03 on the north tower. For cables where no frequency could be measured, those points remain blank on the plot. The remaining graphs for modes 3 through 7 can be found in appendix B in figure 84 through figure 88.

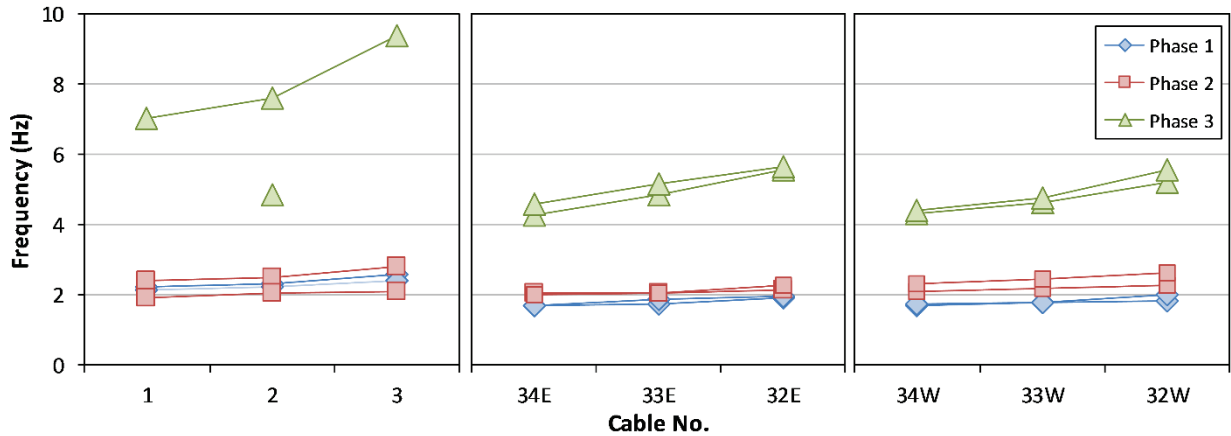

Source: FHWA.

Figure 53. Graph. Comparison of second-mode frequencies for all phases for (left to right) side-span, main-span east, and main-span west cables.

DAMPING

The damping ratios that were extracted for each cable from each phase of testing were plotted together, and the first-mode results are shown in figure 54 and figure 55 for the north and south towers, respectively. While the damping in most cables increased in phase 2 after the installation of the IED+, there were a few cables where damping remained similar or even decreased, which could be due to the way the cable was excited or outside factors such as vibrating construction equipment on the bridge during testing. The damping ratios for phase 3 testing increased for every cable except cable S32E, for which a ratio could not be calculated. It is likely that the accelerometer was mounted too closely to the crosstie on cable S32E, and the increased stiffness resulted in weak excitations. There appears to be no correlation between any of the cables' properties and the resulting ratio, leading to scattered datasets. Damping ratios ranged between 0.13 and 0.3 percent for phase 1, 0.1 and 0.54 for phase 2, and 0.45 and 1.9 percent for phase 3.

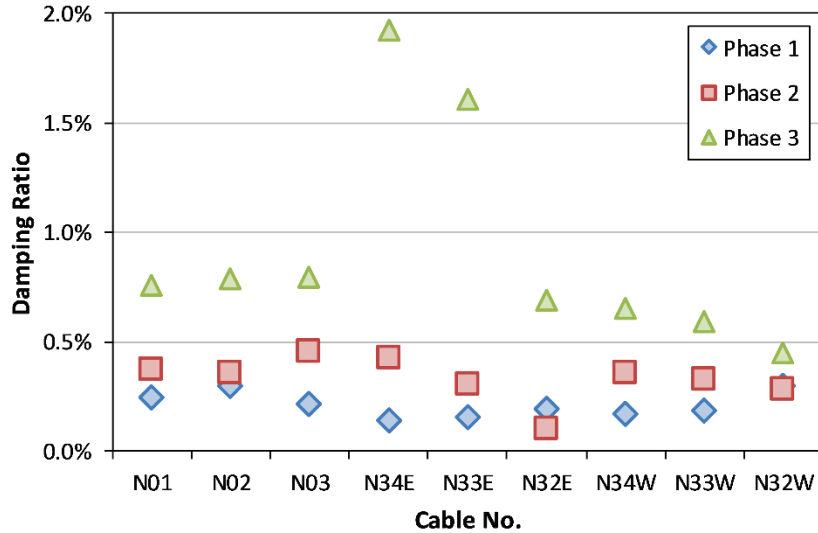

Source: FHWA.

Figure 54. Graph. Comparison of first-mode damping ratios for north-tower cables.

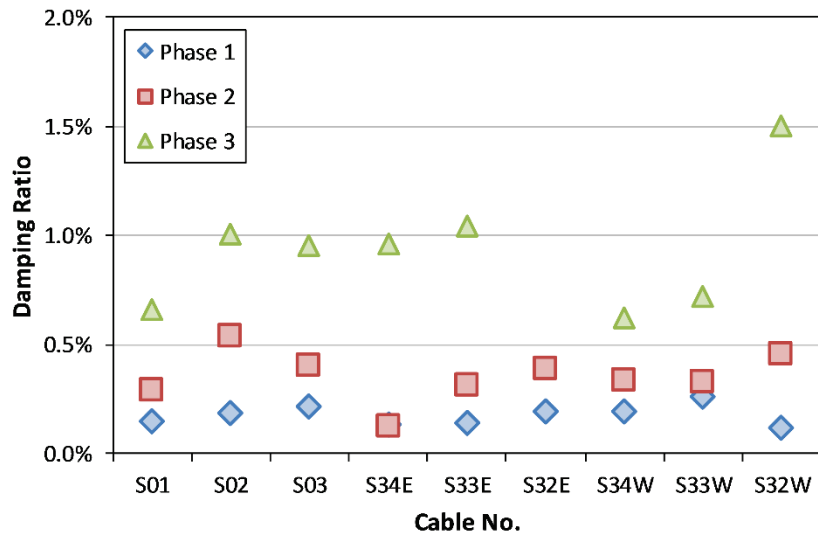

Source: FHWA.

Figure 55. Graph. Comparison of first-mode damping ratios for south-tower cables.

Damping ratios extracted from the second mode across all three phases of testing are plotted in figure 56 and figure 57 for the north and south towers, respectively. As with the first-mode damping ratios, there are no trends among the different phases and different cable types. The values for phases 1 and 2 are generally significantly less than 0.6 percent. Phase 3 values were higher, but only when they could be measured, and for 12 of the cables second-mode damping ratios could not be calculated at all. For those cables that could be measured, second-mode damping ratios ranged between 0.1 and 0.56 percent for phase 1, 0.16 to 0.59 percent for phase 2, and 0.54 and 1.2 percent for phase 3.

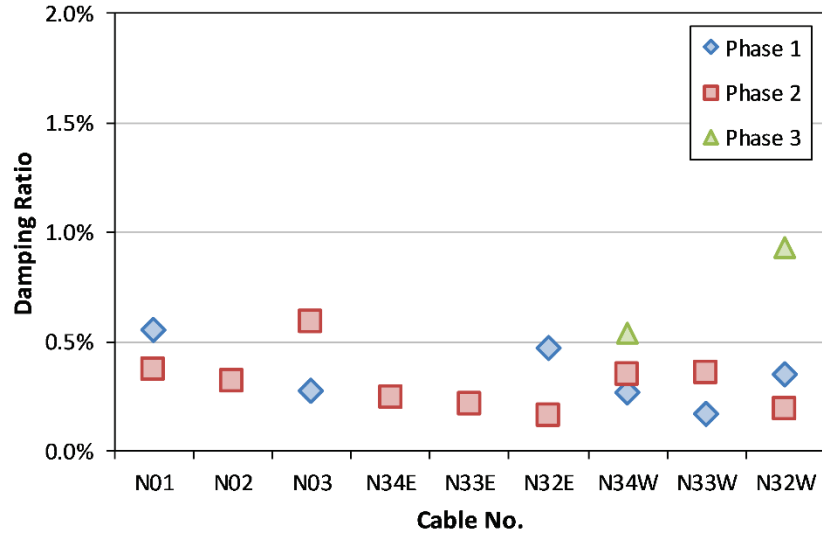

Source: FHWA.

Figure 56. Graph. Comparison of second-mode damping ratios for north-tower cables.

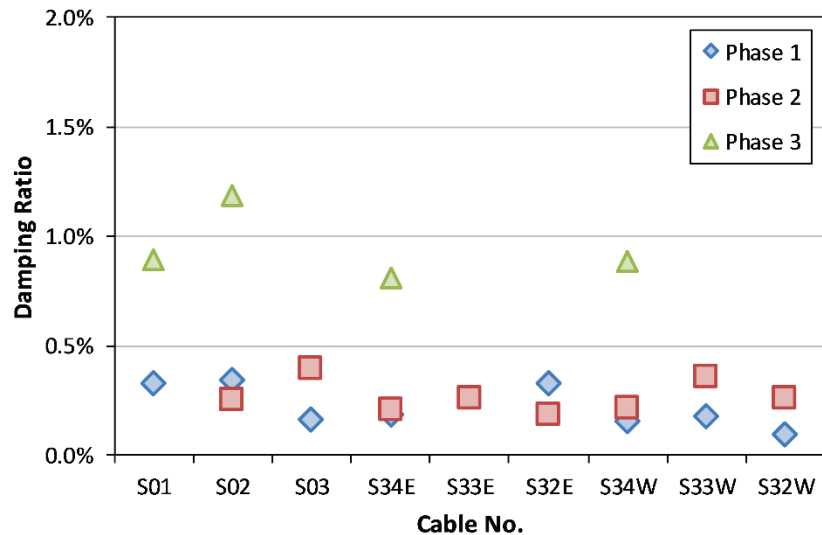

Source: FHWA.

Figure 57. Graph. Comparison of second-mode damping ratios for south-tower cables.

SCRUTON NUMBER

Scruton numbers from the first two phases are compared in figure 58 and figure 59 for the north and south towers, respectively. As noted previously, a recommended minimum Scruton number of 10 is needed for controlling rain- and wind-induced vibrations, although an alternative reduced value of 5 can be considered when the cables are equipped with an aerodynamic surface treatment. These cables featured a double-helical fillet, which qualifies them for the reduced value of 5.

For phase 1 testing, Scruton values all fell less than this recommended value, indicating the need for dampers, crossies, or both. After the introduction of the IED+ in phase 2, most Scruton numbers increased, although more than half were still less than the recommended value. After the installation of crossies in phase 3, all but one of the cables were safely over this minimum value of 5. Scruton numbers ranged between 1.1 and 3.8 in phase 1, between 1.0 and 7.7 in phase 2, and between 4.0 and 18.7 in phase 3. These results confirmed that both dampers and crossies were required.

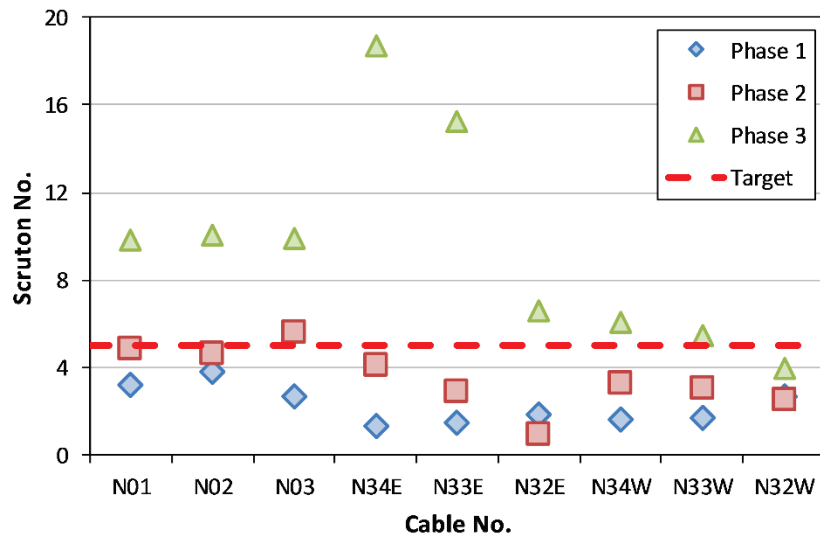

Source: FHWA.

Figure 58. Graph. Comparison of Scruton numbers for north-tower cables.

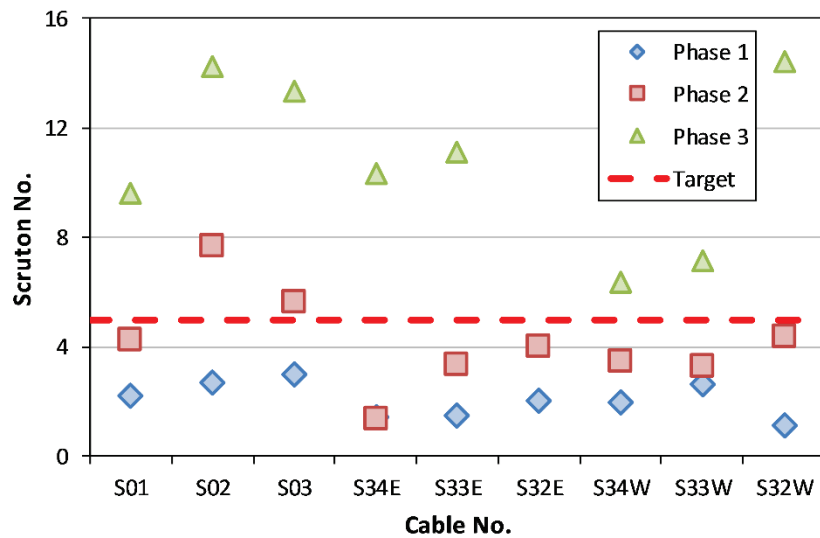

Source: FHWA.

Figure 59. Graph. Comparison of Scruton numbers for south-tower cables.

CHAPTER 8. THEORETICAL FREQUENCIES AND COMPUTER MODELING

METHODS

In addition to simply comparing the field data across each phase of testing, the frequency values were compared against theoretical frequencies calculated using string theory and computer analysis using SAP2000® (SAP) finite element modeling software.⁽²¹⁾

First-mode theoretical frequencies were calculated for each cable using the string-theory equation presented in figure 4. The formula requires three cable properties, including length, tension force, and mass density. Cable coordinates and initial tension forces were obtained from construction drawings from the bridge designer. Since the bridge was under construction during field testing, the weight of certain dead loads that had not been completed—such as railings, concrete barriers, concrete deck sections, deck grouting, and deck overlays—were estimated and subtracted from the initial tension force. The length of the cable was calculated from the geometry of the cable coordinates; however, for phases 2 and 3, it was assumed that the effective length of the cable should be calculated from the end of the guide pipe rather than the total length of the cable, since the guide pipe hinders the free movement of the cable. The length used in the theoretical calculations did not account for sag in the cable. The final input of the formula, the mass density of the cable, was obtained from worksheets from the cable manufacturer, which neatly tabulated the properties of the various components of the cable, including the weight and size of the steel strands and the outer diameter of the HDPE pipe.

The physical cable properties used to calculate theoretical frequencies with string theory were also entered into SAP finite element modeling software to model each span of the bridge.⁽²¹⁾ The main spans were split into separate east and west models for both the north and south towers due to differing tensions caused by the extra cantilevered lanes on the east side. However, the side spans were each modeled as a complete set, including both the east and west cables as they split off on either side of the tower following cables 1–10. The cables were accurately positioned in 3D space using coordinates provided by the designer. One of the biggest advantages to using finite-element modeling was that, in addition to verifying the results from the theoretical calculations and field testing, the effects of adding a crosstie to the system could be explored. From the modeling results, the network of frequencies could be determined and their complex multicable mode shapes visualized.

In SAP, the cables were modeled as consecutive beam elements with varying element lengths and node points whose numbers depended on the length of the cable.⁽²¹⁾ The beam elements were modeled as steel material using an equivalent diameter based on the unit weight values given by the manufacturer. This equivalent diameter was calculated to have the same unit weight as the entire material of the cable, including the HDPE pipe, sheathing, and grease. The beam elements used the elasticity modulus of steel for the entire mass and a flexural stiffness of zero. A flexural stiffness of 0 cannot be programmed into the modeling software; therefore, a very small decimal value was used to produce the same effect. Tension forces were applied to each cable using the p -delta analysis method.

A single line of crosssties was installed in each fan of cables on the bridge. For the side spans, the crossstie was anchored to the deck at the base of cable 10 and extended out, perpendicular to the cables, connecting each consecutive cable until it reached the longest, cable 1. Similarly, for each of the main spans, on both the east and west sides, the crossstie was anchored to the deck at the base of cable 24 and extended out, perpendicular to the cables, until it reached cable 34 in each respective fan.

FREQUENCY COMPARISONS

The first-mode frequencies calculated from string theory were plotted against the results obtained from SAP modeling and the data obtained from field testing.⁽²¹⁾ Figure 60 through figure 65 contain the frequency data from phase 1 testing for the main and side spans. The side-span frequencies are combined in one graph, although the east and west cables are grouped separately. The frequencies from the east and west sides of the main span are produced in separate graphs. As seen in the plots, the theoretical first-mode frequencies match both the field data and computer modeling results closely, although they are off by an average of 3 percent. For some of the shorter cables (which correspond to higher frequencies) on the side spans, the computer modeling calculates a slightly larger frequency than the theoretical values by a few percent, but otherwise the two methods produce extremely similar results.

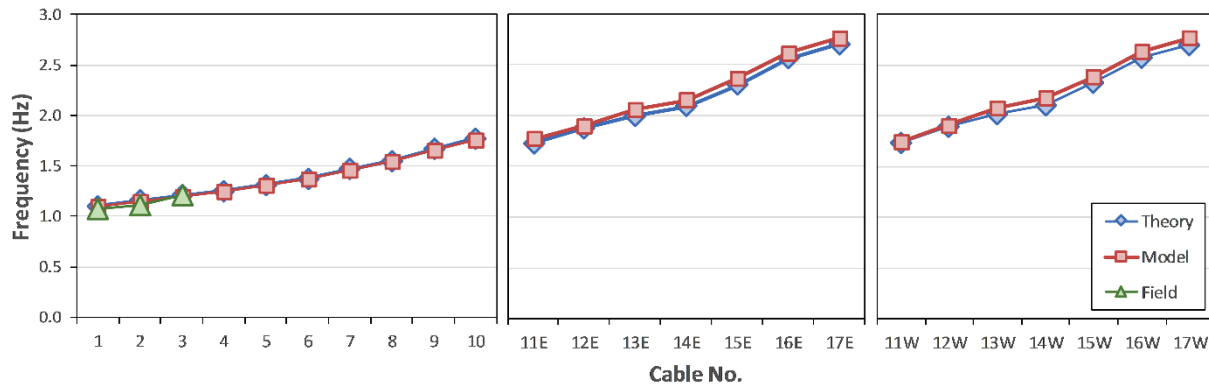

Source: FHWA.

Figure 60. Graph. First-mode frequency comparison for phase 1 conditions for south tower side-span cables.

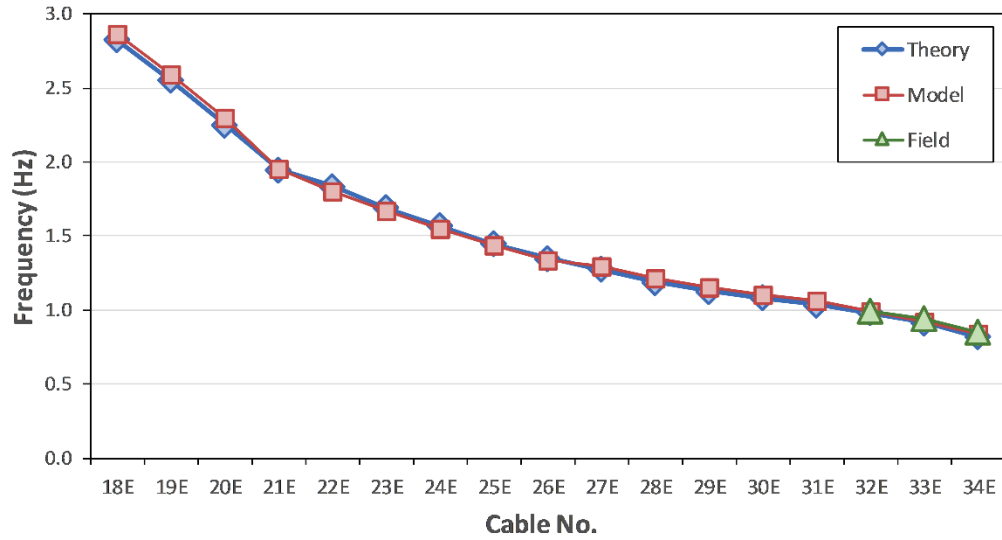

Source: FHWA.

Figure 61. Graph. First-mode frequency comparison for phase 1 conditions for south tower main-span cables on the east side.

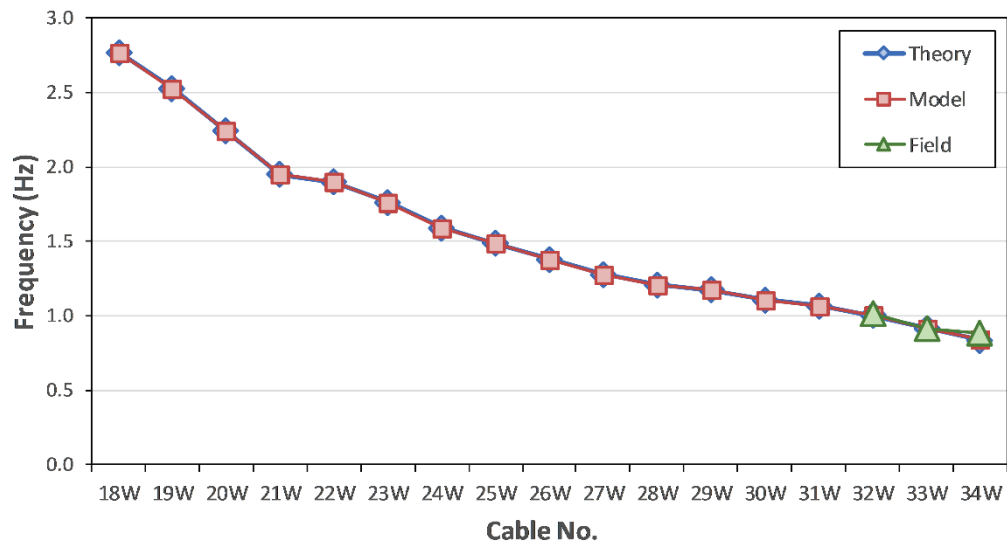

Source: FHWA.

Figure 62. Graph. First-mode frequency comparison for phase 1 conditions for south tower main-span cables on the west side.

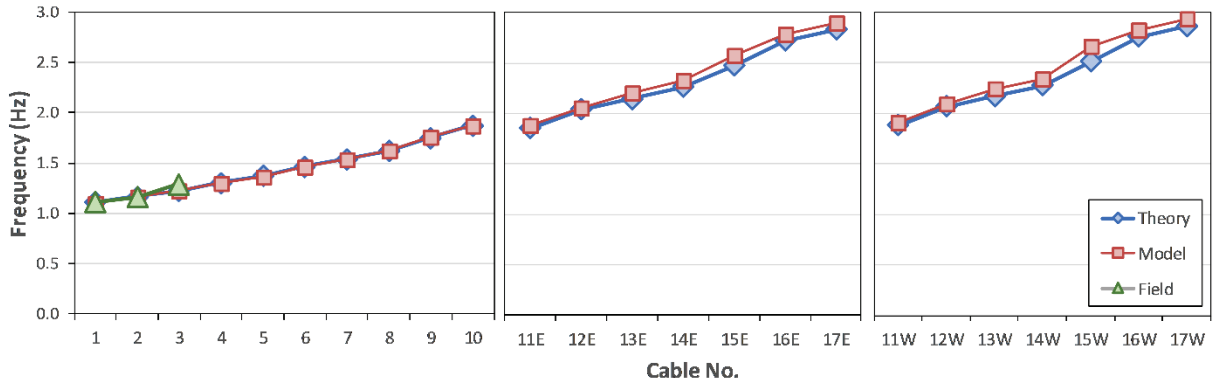

Source: FHWA.

Figure 63. Graph. First-mode frequency comparison for phase 1 conditions for north tower side-span cables.

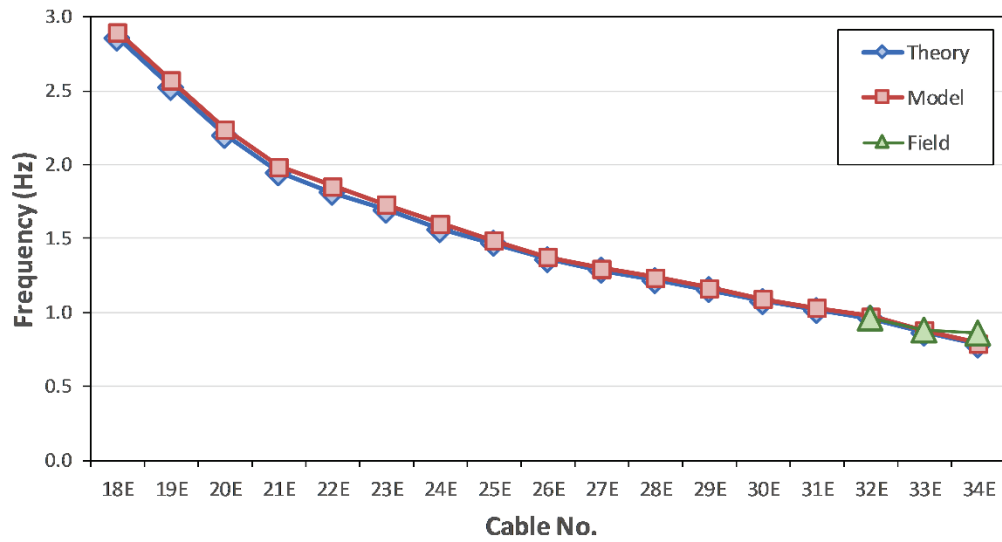

Source: FHWA.

Figure 64. Graph. First-mode frequency comparison for phase 1 conditions for north tower main-span cables on the east side.

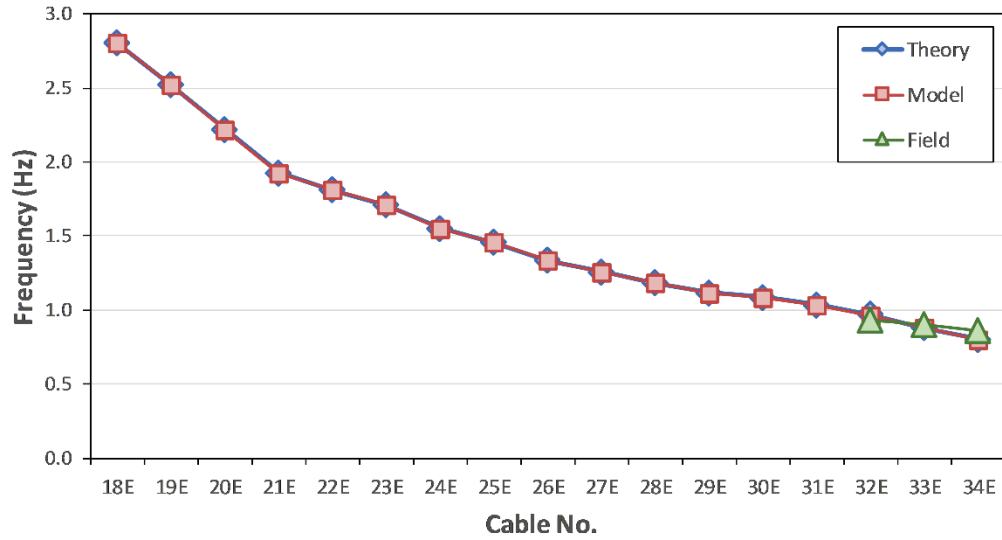

Source: FHWA.

Figure 65. Graph. First-mode frequency comparison for phase 1 conditions for north tower main-span cables on the west side.

Similarly, figure 66 through figure 71 contain the frequency data from phase 2 testing for the side and main spans. Generally, phase 2 testing produced very similar frequencies when compared to phase 1, although they were slightly higher due to the shorter effective length of the cables, which was caused by the restriction of the newly installed dampers at the base of each cable. The missing dead load from concrete barriers, grouting, and the overlay in phase 1 was also added to the tension force. Once again, the field data match the theoretical methods quite well, but are generally a few percent lower. The theoretical methods themselves are nearly equivalent overall, usually within a few percent, but in the shortest cables the SAP model produced frequencies that were up to 4 percent higher.⁽²¹⁾

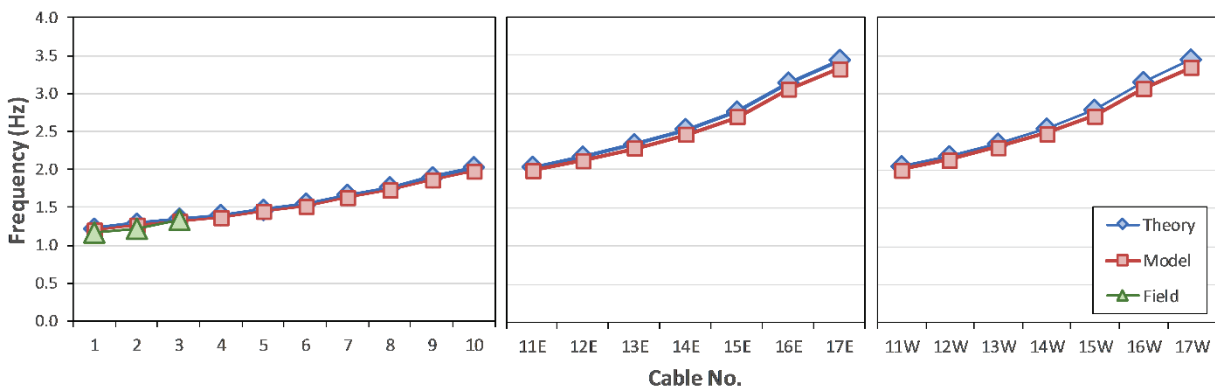

Source: FHWA.

Figure 66. Graph. First-mode frequency comparison for phase 2 conditions for south tower side-span cables.

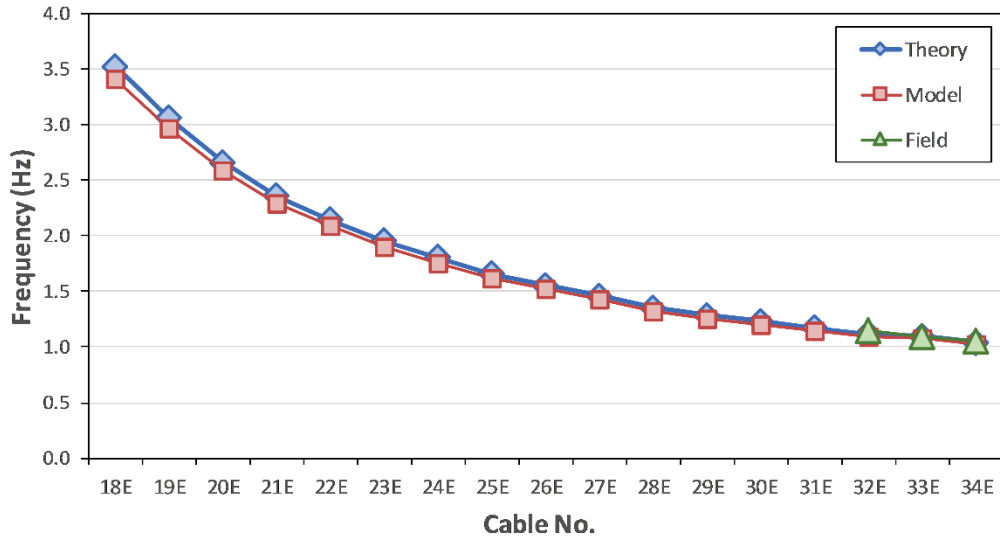

Source: FHWA.

Figure 67. Graph. First-mode frequency comparison for phase 2 conditions for south tower main-span cables on the east side.

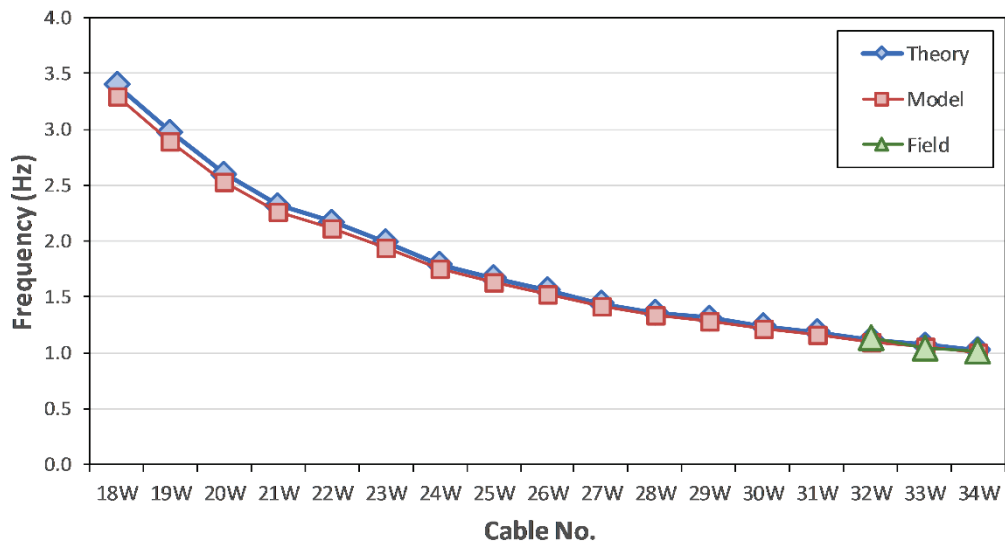

Source: FHWA.

Figure 68. Graph. First-mode frequency comparison for phase 2 conditions for south tower main-span cables on the west side.

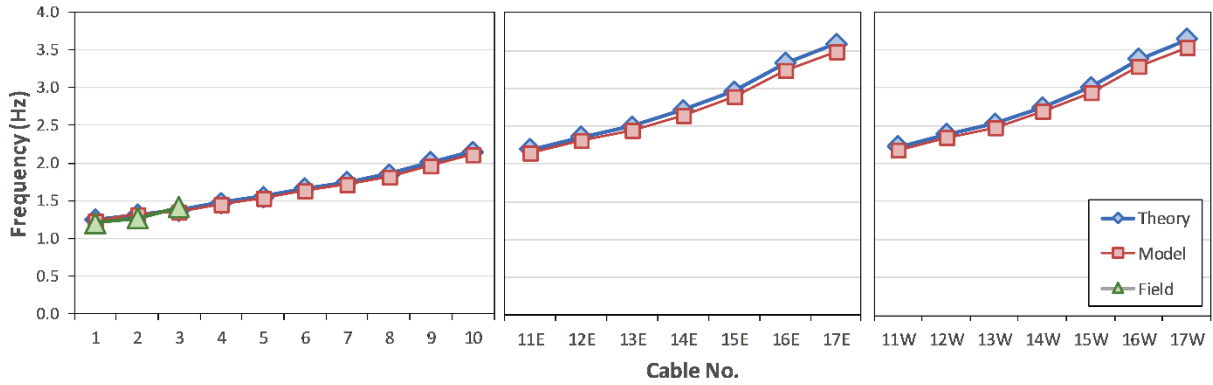

Source: FHWA.

Figure 69. Graph. First-mode frequency comparison for phase 2 conditions for north tower side-span cables.

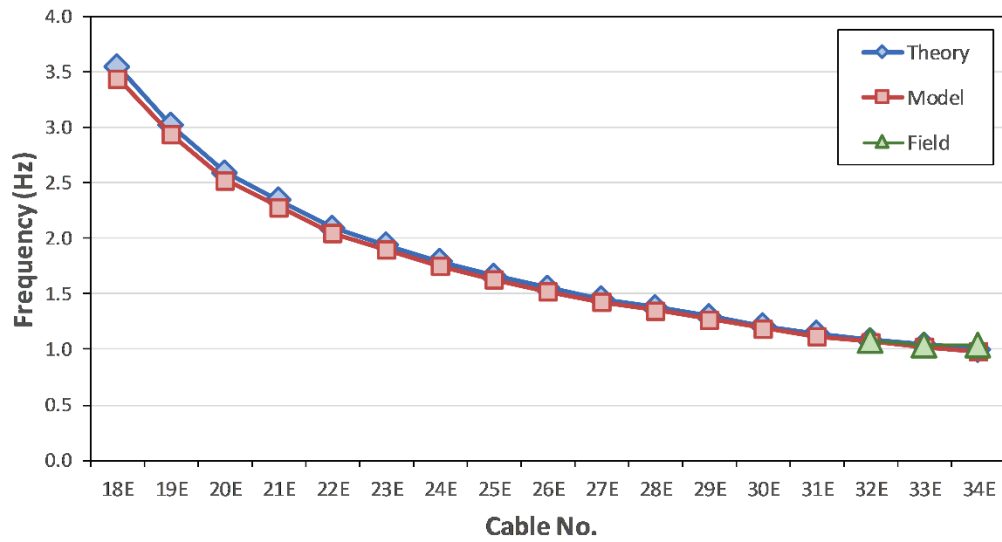

Source: FHWA.

Figure 70. Graph. First-mode frequency comparison for phase 2 conditions for north tower main-span cables on the east side.

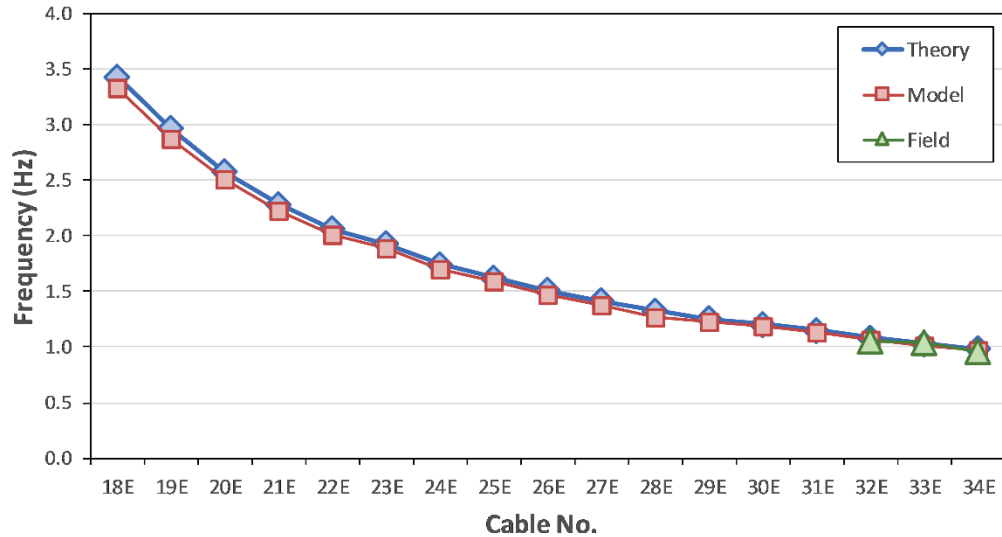

Source: FHWA.

Figure 71. Graph. First-mode frequency comparison for phase 2 conditions for north tower main-span cables on the west side.

As mentioned earlier in the section, the cable fans were modeled in SAP with a single line of crossties to simulate the behavior of phase 3 testing. While SAP could easily produce a table of eigenvalues and frequencies for the global network cable system, it was not possible to isolate each individual cable to plot its first-mode frequencies as was done in figure 66 through figure 71.⁽²¹⁾ However, a decision was made to plot the field data from phase 3 testing against string theory, plugging in the distance from the guide pipe to the crosstie as the new effective length for each cable. The results are shown in figure 72 through figure 77 for side and main spans. The installed line of crossties did not intersect the shorter cables in the fan, so those were not included in the plot. Additionally, the next shortest cable was also left off the plot because its theoretical frequency skewed the scale of the axes.

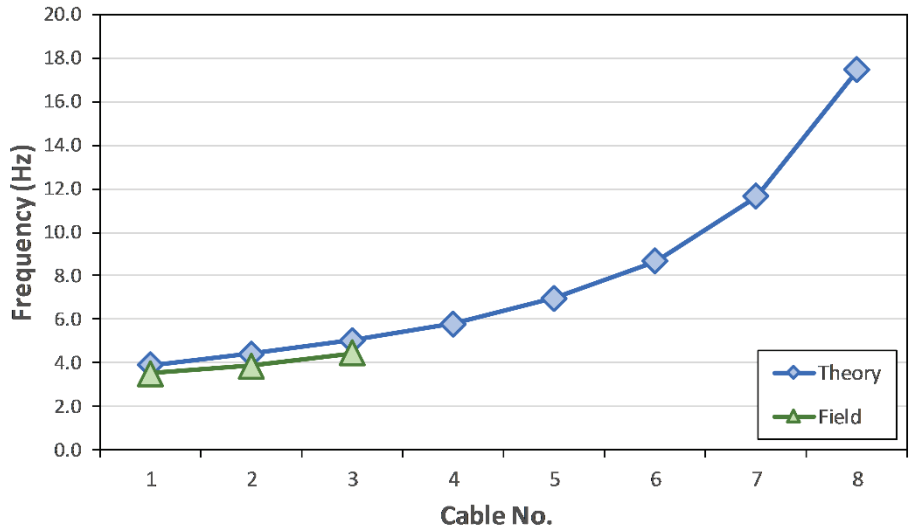

Source: FHWA.

Figure 72. Graph. First-mode frequency comparison for phase 3 conditions for south tower side-span cables.

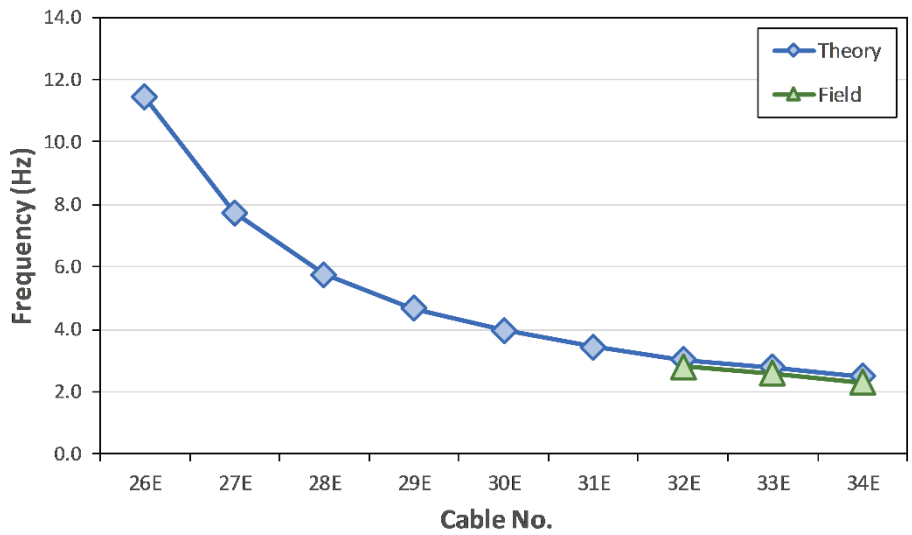

Source: FHWA.

Figure 73. Graph. First-mode frequency comparison for phase 3 conditions for south tower main-span cables on the east side.

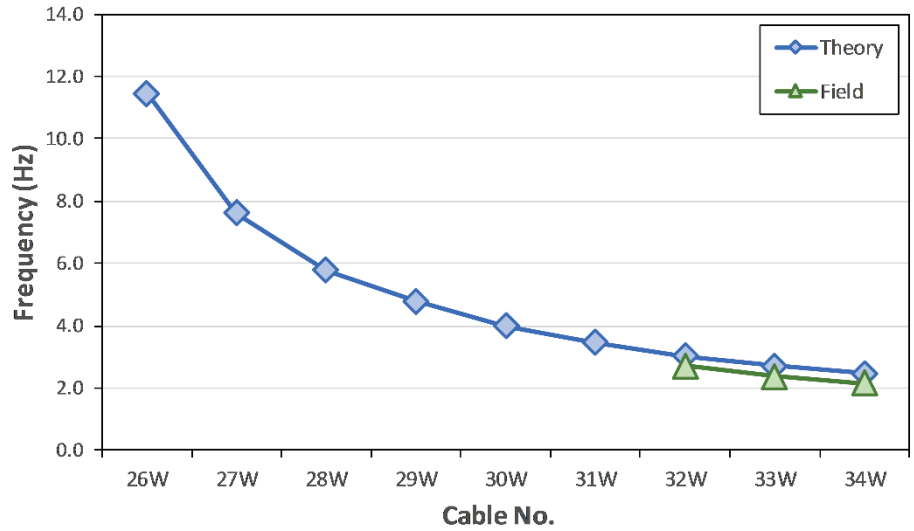

Source: FHWA.

Figure 74. Graph. First-mode frequency comparison for phase 3 conditions for south tower main-span cables on the west side.

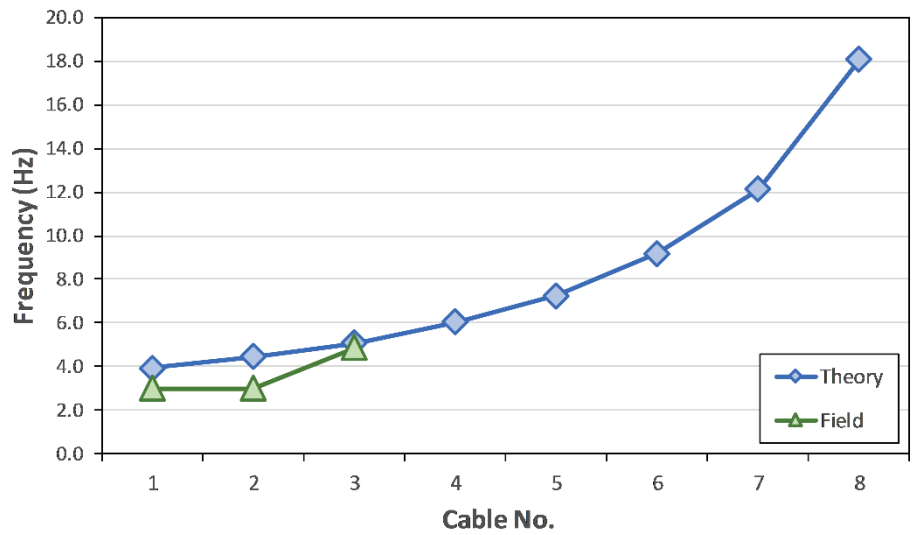

Source: FHWA.

Figure 75. Graph. First-mode frequency comparison for phase 3 conditions for north tower side-span cables.

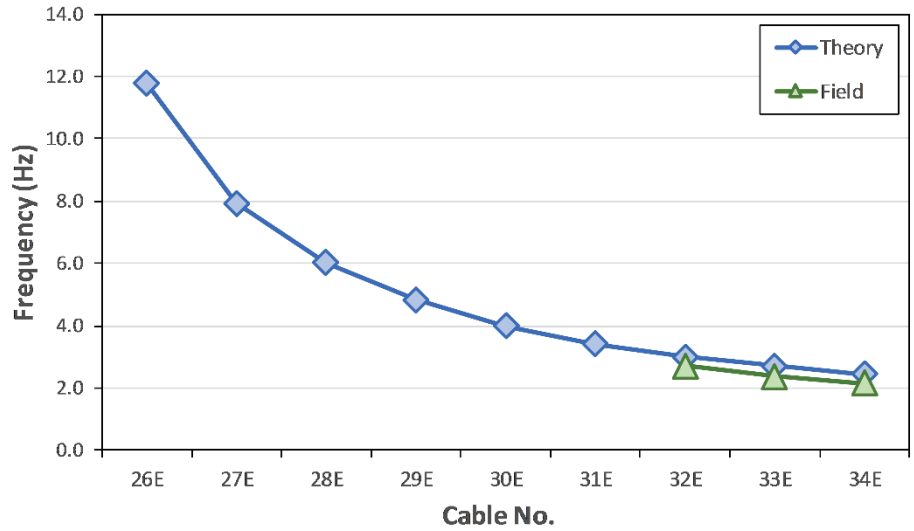

Source: FHWA.

Figure 76. Graph. First-mode frequency comparison for phase 3 conditions for north tower main-span cables on the east side.

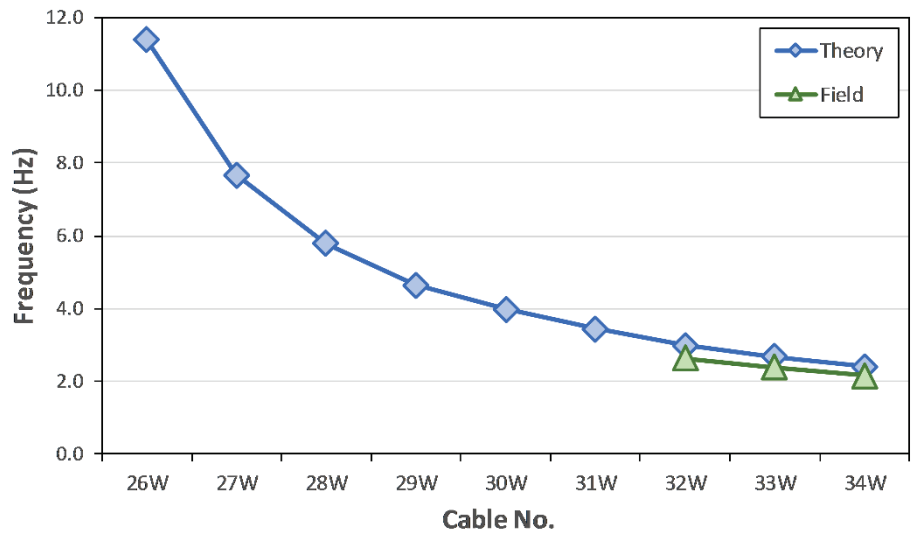

Source: FHWA.

Figure 77. Graph. First-mode frequency comparison for phase 3 conditions for north tower main-span cables on the west side.

Interestingly, the two curves match somewhat well, although not as well as the first two phases. The field values are lower than the theoretical values by about 10 percent in most cases, which could be the result of incorrect estimation of the actual crosstie locations. However, the curves are close enough to verify that the higher frequencies obtained during phase 3 testing are a result of the crossties producing shorter effective cable lengths. It also explains the behavior in the spectral density plots, where it seemed multiple sets of natural frequencies were observed. The more powerful frequencies were the result of the shorter effective cable lengths, while the weaker natural frequencies came from the entire length of the cable still resonating.

These figures imply that as more crossties are added, the effective lengths of the cables are quickly diminished in size, therefore raising the natural frequencies of the cable system. These higher frequencies require more power for major cable excitations, proving that crossties are an effective technique for cable vibration mitigation. Although some of the original frequencies associated with the full length of the cable still exist, they are greatly weakened.

CROSSTIE ANALYSIS

Visualization of the mode shapes was an additional benefit of modeling the cable networks and crossties in SAP.⁽²¹⁾ The simulations were a useful tool for identifying how the behavior of the system changed as crossties were added. Figure 78 shows the first four mode shapes for the side span of the bridge with dampers but no crossties attached, with cable properties equivalent to phase 2 of testing, where F_n is the natural frequency of the n th mode of vibration. Similarly, figure 79 shows the first four mode shapes for the main span with dampers but no crossties.

Since there are no crossties installed during phase 2 testing, the mode shapes of the cable network system correspond to the natural modes of the individual cables. Notably, around the 12th mode, the higher modes of the longer cables start to merge with the first mode of the shorter cables. From there, the mode-frequency values for the cable system were intertwined among the cables.

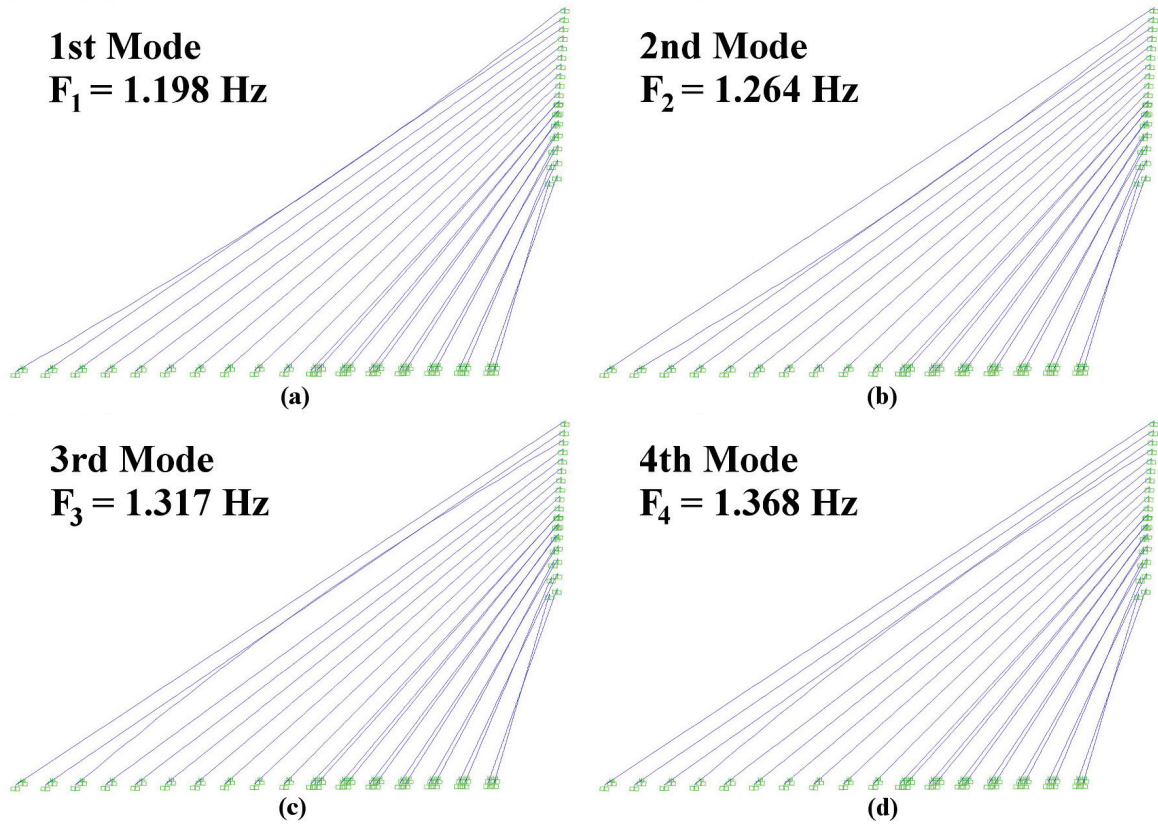

Source: FHWA.

Figure 78. Image. Vibration mode shapes of the south tower side span with no crosssties for the (a) first, (b) second, (c) third, and (d) fourth modes.

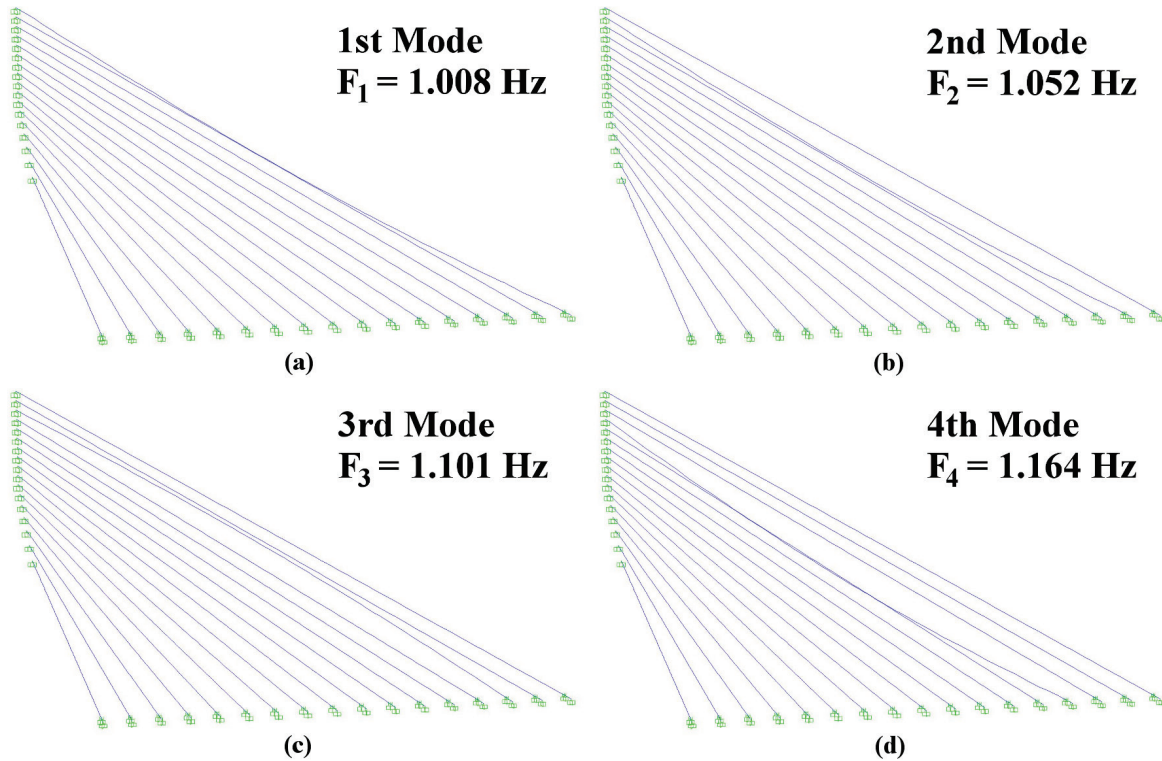

Source: FHWA.

Figure 79. Image. Vibration mode shapes of the south tower main span with no crossties for the (a) first, (b) second, (c) third, and (d) fourth modes.

A single line of crossties was added to the model, producing an identical setup to the configuration present during phase 3 testing. Figure 80 shows the first four mode shapes for the side span with a single line of crossties, while figure 81 shows the same results for the main span. The frequencies did not increase significantly from the addition of crossties, but it appears from the mode shapes in these figures that the initial modes are the longer cables moving out-of-plane. Unlike previous studies in which cable movement could be locked in-plane, this cable coordinate system contained anchor positions located in 3D space, which precluded adding a two-dimensional constraint.

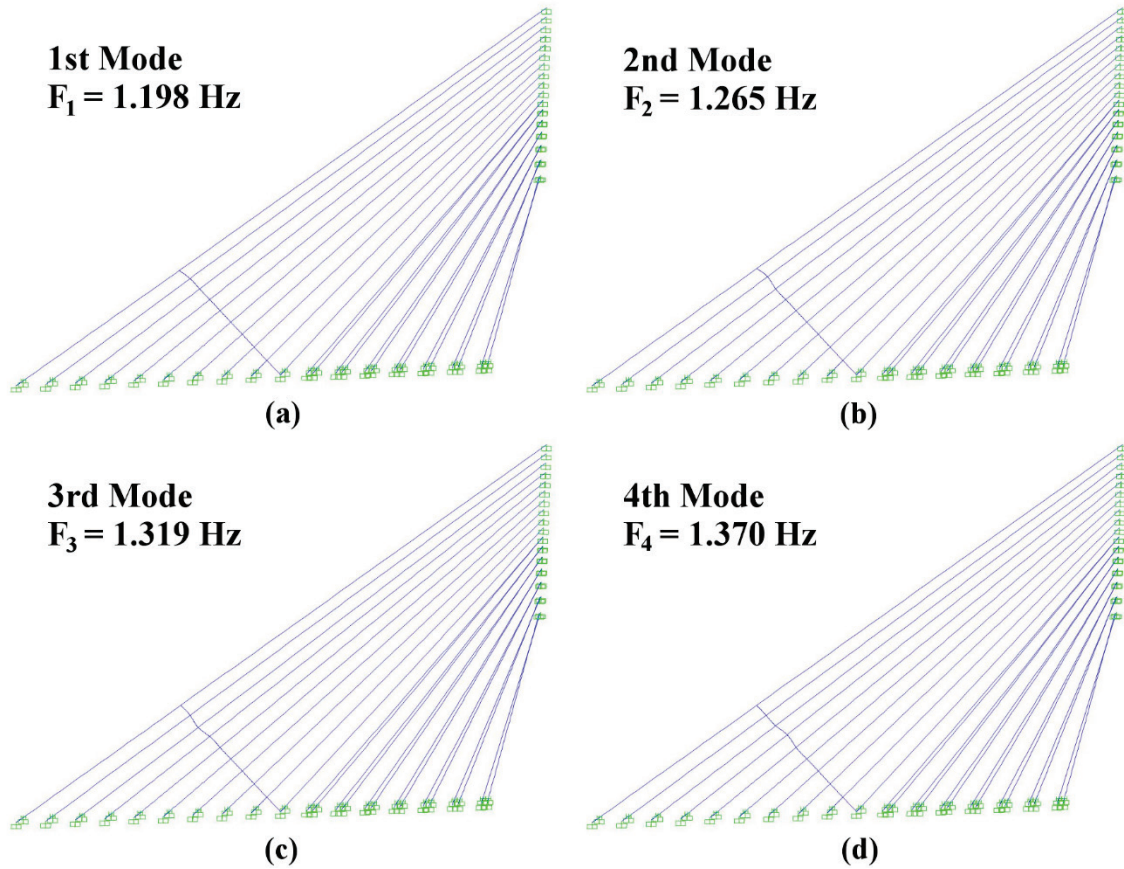

Source: FHWA.

Figure 80. Image. Vibration mode shapes of the south tower side span with a single line of cross-ties for the (a) first, (b) second, (c) third, and (d) fourth modes.

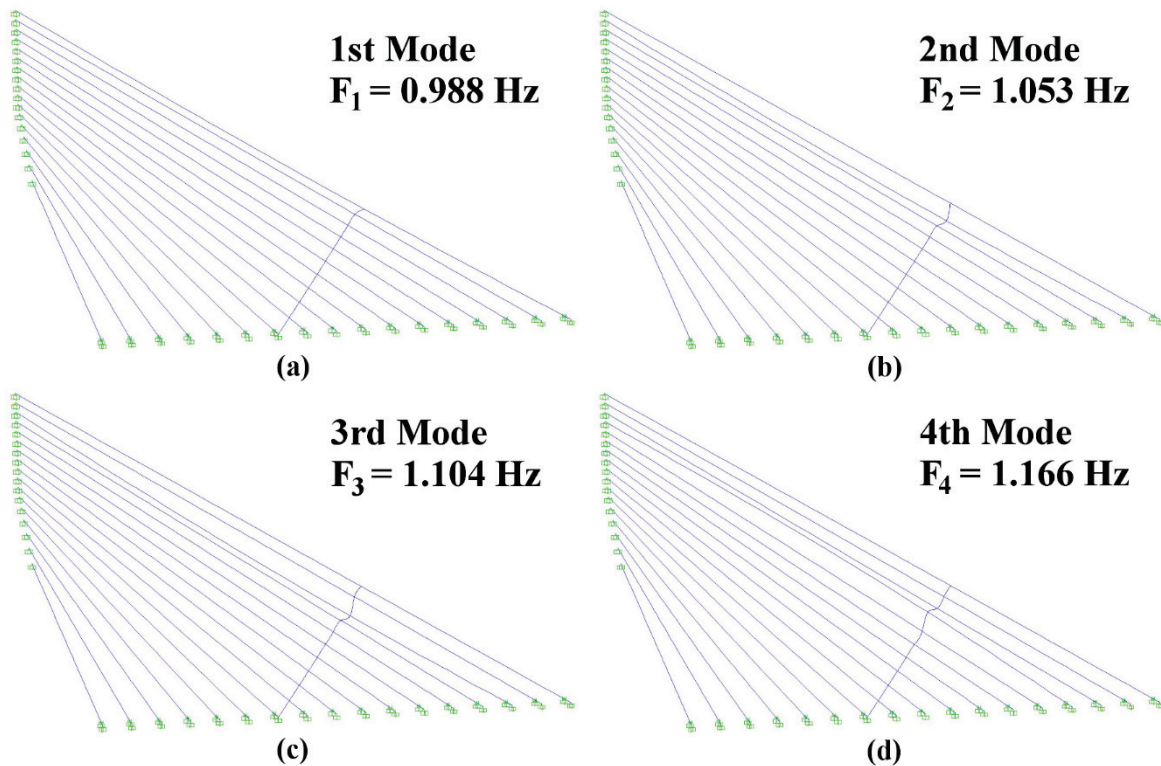

Source: FHWA.

Figure 81. Image. Vibration mode shapes of the south tower main span with a single line of crossties for the (a) first, (b) second, (c) third, and (d) fourth modes.

MODE FREQUENCY EVOLUTION

Mode frequency evolution charts illustrating the three phases for both spans of the bridge are presented in figure 82 and figure 83. A similar approach has been used by Abdel-Ghaffar and Khalifa (1991)⁽²²⁾ and Caracoglia and Jones (2005)⁽²³⁾ and was studied extensively in a 2007 FHWA report, which compared numerous different configurations of crossties and their effects on mode frequency.⁽³⁾

Unlike the earlier FHWA report, which compared the effects of zero to four lines of crossties, this bridge only had a maximum of one line of crossties installed; therefore, only phases 1 through 3 were compared. Usually, for such plots of networked cables, it is common to observe a sequence of global modes followed by a plateau of densely populated local modes, which is then followed by a second set of global modes, and so on. Such behavior is not totally obvious from these results, but it is more evident from the plot of the main span shown in figure 83. In both plots, the single line of crossties, shown labeled as phase 3, rises slightly faster than its counterparts before plateauing around 10–15 Hz. Without any crossties, the system modes are the natural modes of the individual cables. Phase 2 frequencies are slightly higher than phase 1 frequencies due to the shorter effective length of the cables after the installation of the damper and guide pipes and slightly increased tension due to the effects of the full dead load.

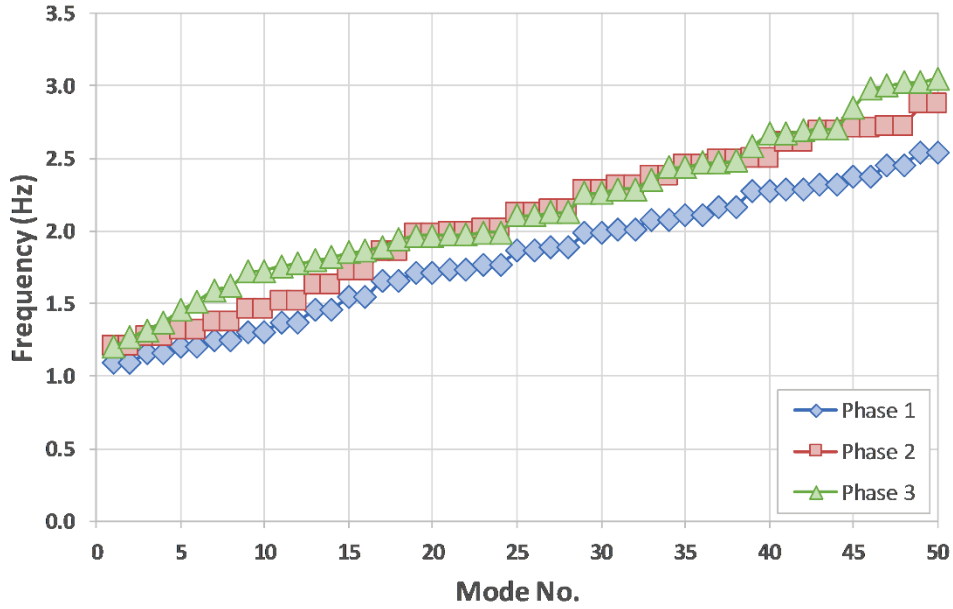

Source: FHWA.

Figure 82. Graph. Mode-frequency evolution comparing crosstie configurations for the south tower side span.

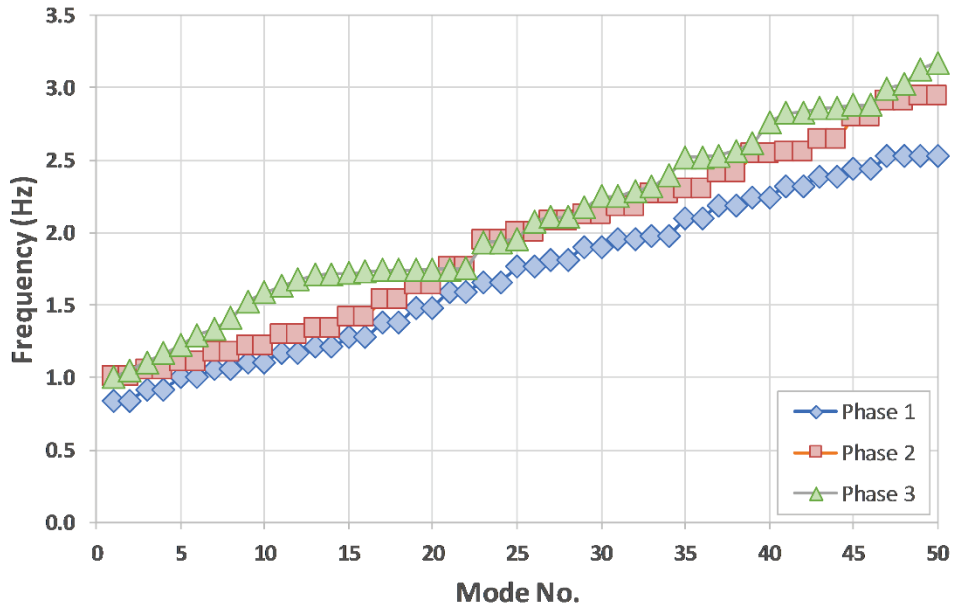

Source: FHWA.

Figure 83. Graph. Mode-frequency evolution comparing crosstie configurations for the south tower main span.

CHAPTER 9. CONCLUSIONS

Vibration testing was performed on the stay cables of the Leonard P. Zakim Bunker Hill Bridge, located in the city of Boston, MA, by manually exciting the stay cables and measuring the decay with accelerometers and a portable data acquisition system. The vibration data underwent post-processing using various filters. Natural frequencies and damping ratios were extracted for the tested stay cables. Confidence intervals on the mean were found for the cables in both the first and second modes of damping.

For phase 1 testing, measured first-mode frequencies for side-span cables tested varied from 1.07 to 1.29 Hz, while those for the longer main-span cables varied from 0.86 to 1.01 Hz. Following the addition of dampers to the cables in phase 2 testing, the frequencies remained similar, with values of 0.96 to 1.4 Hz for side-span cables and 1.01 to 1.3 Hz for main-span cables. After the installation of a single line of crossties in phase 3 testing, the cable networks stiffened and increased the first-mode frequencies to ranges from 2.93 to 5.08 Hz for the side-span cables and 2.15 to 2.83 Hz for the main-span cables. Similar cables tested in different quadrants around the bridge compared favorably among the main span cables during each phase of testing, but the side-span cables did show more variance. Measured frequencies compared well with theoretical values based on the string theory and computer modeling simulations.

For phase 1 testing, damping ratios for all cables tested varied from 0.12 to 0.3 percent for the first mode and 0.1 and 0.56 percent for the second mode. For phase 2 testing, damping ratios remained similar, varying from 0.1 to 0.54 percent for the first mode and 0.16 to 0.59 percent for the second mode. Damping ratios were more difficult to calculate from phase 3 test data due to complications in extracting bandpass filter frequencies from the spectral density plots. Damping ratios that were obtained ranged from 0.45 to 1.9 percent for the first mode and from 0.54 to 1.2 percent for the second mode. It was noted that the damping ratios for tested cables did not increase significantly after the addition of IED+ dampers in phase 2. It remains unclear if their ineffectiveness was due to the damper's physical properties or the location chosen for their installation.

The Scruton numbers, which were used as a criterion to determine effective cable vibration mitigation, were calculated for all phases. They ranged from 1.1 to 3.8 for phase 1 testing, between 1.0 and 7.7 for phase 2 testing, and between 4.0 and 18.7 for phase 3 testing. For the first two phases of testing, most of the cables tested had values less than the target value of 5 for cables with aerodynamic surface treatments, such as a helical fillet. After the installation of a row of crossties, the Scruton numbers increased dramatically, and all but one cable was over the target value.

Further investigation into the first-mode frequencies obtained during phase 3 testing showed that they matched up well when plotted against theoretical frequencies calculated with string theory using a shorter effective length equal to the distance from the bridge deck to the crosstie. This finding confirms that the crossties help stiffen the system by shortening the effective length of each cable segment.

APPENDIX A. MODE FREQUENCY TABLES

Table 8. Phase 1 mode frequencies (Hz).

Cable	Run	Box 1							Box 2						
		1	2	3	4	5	6	7	1	2	3	4	5	6	7
N01	1*	—	—	—	—	—	—	—	—	—	—	—	—	—	—
N01	2**	1.11	2.22	3.33	4.43	5.54	6.67	7.76	1.11	2.22	3.32	4.43	5.54	6.64	7.76
N01	3**	1.11	2.22	3.33	4.43	5.54	6.64	7.75	1.11	2.22	3.33	4.43	5.54	6.65	7.76
N01	4**	1.11	2.22	3.33	4.43	5.55	6.65	7.75	1.11	2.22	3.33	4.44	5.54	6.65	7.76
N01	5**	1.11	2.22	3.33	4.43	5.55	6.65	7.75	1.11	2.22	3.33	4.44	5.54	6.65	7.75
N01	6**	1.11	2.22	3.33	4.43	5.54	6.65	7.75	1.11	2.22	3.33	4.44	5.54	6.65	7.75
N01	7	1.11	2.22	3.33	4.44	5.55	6.65	7.75	1.11	2.22	3.33	4.44	5.55	6.65	7.75
N02	1*	—	—	—	—	—	—	—	—	—	—	—	—	—	—
N02	2**	1.16	2.33	3.48	4.64	5.80	6.96	8.13	1.16	2.32	3.48	4.64	5.80	6.96	8.12
N02	3**	1.16	2.33	3.48	4.64	5.80	6.95	8.13	1.16	2.32	3.48	4.64	5.80	6.96	8.12
N02	4**	1.16	2.33	3.48	4.64	5.80	6.96	8.11	1.16	2.32	3.48	4.64	5.80	6.96	8.12
N02	5**	1.16	2.33	3.48	4.64	5.80	6.95	8.13	1.16	2.32	3.48	4.64	5.80	6.96	8.11
N02	6**	1.16	2.33	3.48	4.64	5.79	6.95	8.12	1.16	2.32	3.48	4.64	5.79	6.96	8.12
N03	1*	—	—	—	—	—	—	—	—	—	—	—	—	—	—
N03	2**	1.29	2.59	3.89	5.19	6.49	7.79	9.11	1.29	2.60	3.89	5.19	6.49	7.79	9.09
N03	3**	1.29	2.59	3.89	5.18	6.47	7.79	9.11	1.29	2.60	3.89	5.20	6.49	7.78	9.09
N03	4**	1.29	2.59	3.89	5.18	6.49	7.79	9.11	1.29	2.60	3.89	5.20	6.49	7.81	9.11
N03	5**	1.30	2.59	3.89	5.18	6.50	7.79	9.10	1.30	2.60	3.89	5.20	6.50	7.79	9.08
N34E	1*	—	—	—	—	—	—	—	—	—	—	—	—	—	—
N34E	2**	0.86	1.71	2.56	3.44	4.28	—	5.98	0.86	1.72	2.58	3.44	4.29	—	6.01
N34E	3**	0.86	1.71	—	3.44	—	—	—	0.86	1.71	2.58	3.44	—	—	—
N34E	4**	0.86	1.71	—	3.44	—	—	—	0.86	1.72	2.58	3.43	—	—	—
N34E	5**	0.86	1.71	—	3.44	—	—	—	0.86	1.71	2.58	3.42	—	—	—
N34E	6**	0.86	1.71	—	—	—	—	—	0.86	1.71	2.58	3.44	—	—	—
N34E	7**	0.86	1.71	—	—	—	—	—	0.86	1.71	2.58	—	—	—	—
N33E	1**	0.89	1.77	2.66	3.53	4.42	5.31	6.20	0.89	1.76	2.64	3.55	4.41	5.31	6.18

Cable	Run	Box 1							Box 2						
		1	2	3	4	5	6	7	1	2	3	4	5	6	7
N33E	2**	0.89	1.75	2.66	3.54	4.42	5.31	6.20	0.89	1.76	2.64	3.54	4.42	5.31	6.19
N33E	3**	0.89	1.75	2.66	3.53	4.42	5.31	6.18	0.89	1.76	2.66	3.54	4.42	5.31	6.18
N33E	4*	—	—	—	—	—	—	—	—	—	—	—	—	—	—
N33E	5**	0.89	1.77	2.66	3.53	4.43	5.30	6.18	0.89	1.76	2.66	3.55	4.43	5.30	6.18
N33E	6**	0.89	1.77	2.66	3.53	4.43	5.32	6.18	0.89	1.76	2.66	3.55	4.43	5.31	6.18
N33E	7**	0.89	1.77	2.66	3.55	4.43	5.32	6.20	0.89	1.76	2.64	3.55	4.43	5.32	6.20
N32E	1**	0.96	1.91	2.87	3.82	4.80	5.74	6.71	0.96	1.90	2.88	3.83	4.79	5.74	6.71
N32E	2**	0.96	1.92	2.88	3.83	4.80	5.76	6.73	0.96	1.91	2.88	3.85	4.80	5.76	6.73
N32E	3**	0.96	1.92	2.88	3.83	4.81	5.76	6.73	0.96	1.92	2.88	3.85	4.80	5.76	6.72
N32E	4**	0.96	1.92	2.88	3.83	4.79	5.76	6.73	0.96	1.91	2.88	3.83	4.80	5.73	6.73
N32E	5**	0.96	1.92	2.88	3.83	4.79	5.76	6.73	0.96	1.90	2.88	3.83	4.81	5.80	6.70
N32E	6**	0.96	1.92	2.88	3.83	4.79	5.76	6.73	0.96	1.91	2.88	3.83	4.83	5.75	6.72
N32E	7*	—	—	—	—	—	—	—	—	—	—	—	—	—	—
N34W	1*	—	—	—	—	—	—	—	—	—	—	—	—	—	—
N34W	2	0.86	1.72	2.58	3.43	4.29	5.16	6.01	0.86	1.72	2.58	3.43	4.29	5.15	6.03
N34W	3*	—	—	—	—	—	—	—	—	—	—	—	—	—	—
N34W	4	0.86	1.71	2.58	3.44	4.29	5.16	6.00	0.86	1.71	2.55	3.43	4.29	—	—
N34W	5	0.86	1.72	2.58	3.44	4.27	—	—	0.86	1.72	2.58	3.44	4.30	—	—
N34W	6	0.86	1.71	2.58	3.44	4.30	5.18	5.96	0.86	1.71	2.59	3.44	4.30	5.20	—
N34W	7	0.86	1.71	2.58	3.44	4.30	5.01	5.75	0.86	1.71	2.58	3.44	4.29	5.01	5.73
N34W	8	0.86	1.71	2.58	3.44	4.30	—	—	0.86	1.71	2.58	3.44	—	—	—
N33W	1*	—	—	—	—	—	—	—	—	—	—	—	—	—	—
N33W	2	0.90	1.79	2.66	3.58	4.43	5.30	6.26	0.90	1.79	2.66	3.58	4.43	5.27	6.27
N33W	3	0.90	1.79	2.68	3.58	4.48	—	—	0.90	1.79	2.67	3.58	4.48	—	—
N33W	4	0.90	1.79	2.68	3.57	4.48	5.37	6.26	0.90	1.79	2.68	3.57	4.48	—	6.26
N33W	5	0.90	1.79	2.69	3.57	4.49	5.38	6.27	0.90	1.79	2.69	3.58	4.49	5.38	6.27
N33W	6	0.90	1.79	2.69	3.57	4.48	5.37	6.26	0.90	1.79	2.68	3.57	4.48	5.37	6.26
N33W	7	0.90	1.79	2.68	3.57	4.47	5.37	6.26	0.90	1.79	2.68	3.57	4.48	5.37	6.26
N32W	1	0.93	1.85	2.78	3.70	4.64	5.44	6.24	0.93	1.85	2.78	3.70	4.64	5.44	6.24
N32W	2	0.93	1.86	2.78	3.70	4.64	5.57	6.26	0.93	1.86	2.78	3.70	4.64	5.58	6.30

Cable	Run	Box 1							Box 2						
		1	2	3	4	5	6	7	1	2	3	4	5	6	7
N32W	3	0.93	1.86	2.77	3.70	4.64	5.59	6.51	0.93	1.86	2.78	3.70	4.64	5.55	6.51
N32W	4	0.93	1.86	2.76	3.70	4.59	5.42	6.36	0.93	1.86	2.76	3.70	4.64	5.42	6.36
N32W	5	0.93	1.86	2.77	3.70	4.59	5.43	6.31	0.93	1.86	2.77	3.70	4.60	5.43	6.32
N32W	6	0.93	1.86	—	3.71	4.63	—	—	0.93	1.85	2.78	3.71	4.60	5.57	6.31
S01	1	1.07	2.12	3.22	4.29	5.33	6.43	7.46	1.07	2.12	3.22	4.29	5.37	6.43	7.46
S01	2	1.07	2.12	3.17	4.29	5.30	6.43	7.35	1.07	2.12	3.22	4.29	5.37	6.43	7.35
S01	3	1.07	2.13	—	4.29	5.37	6.44	—	1.07	2.13	3.22	4.29	5.37	6.43	—
S01	4	1.07	2.13	3.22	4.29	5.36	6.43	7.51	1.07	2.13	3.22	4.29	5.37	6.43	7.51
S01	5	1.07	2.13	—	4.29	5.37	6.43	7.40	1.07	2.13	3.22	4.29	5.37	6.43	7.40
S02	1*	—	—	—	—	—	—	—	—	—	—	—	—	—	—
S02	2	1.11	2.22	3.32	4.46	5.57	6.68	7.79	1.11	2.22	3.35	4.46	5.57	6.68	7.79
S02	3	1.11	2.22	3.31	4.44	5.57	6.68	7.79	1.11	2.22	3.34	4.45	5.56	6.67	7.80
S02	4	1.11	2.23	3.35	4.44	5.57	6.68	7.78	1.11	2.22	3.34	4.45	5.57	6.68	7.79
S02	5	1.11	2.23	—	4.44	5.57	6.68	7.79	1.11	2.23	3.34	4.45	5.57	6.68	7.79
S02	6	1.11	2.22	—	4.44	5.57	6.68	7.78	1.11	2.22	3.34	4.45	5.56	6.68	7.79
S02	7	1.11	2.23	—	4.44	5.57	6.68	7.79	1.11	2.23	3.34	4.45	5.57	6.68	7.79
S03	1*	—	—	—	—	—	—	—	—	—	—	—	—	—	—
S03	2	1.21	2.42	3.63	4.82	6.04	7.24	8.46	1.21	2.42	3.63	4.83	6.04	7.26	8.47
S03	3	1.21	2.42	3.63	4.82	6.04	7.26	8.46	1.21	2.42	3.63	4.82	6.03	7.26	8.46
S03	4	1.21	2.42	3.63	4.82	6.03	7.24	8.46	1.21	2.42	3.63	4.82	6.03	7.24	8.46
S03	5	1.21	2.42	3.61	4.82	6.03	7.25	8.46	1.21	2.42	3.63	4.82	6.03	7.25	8.46
S03	6	1.21	2.42	3.63	4.82	6.03	7.25	8.46	1.21	2.42	3.63	4.82	6.03	7.24	8.46
S03	7	1.21	2.42	3.63	4.82	6.03	7.26	8.45	1.21	2.42	3.63	4.82	6.03	7.26	8.46
S34E	1	0.86	1.70	—	3.39	4.25	5.09	5.96	0.86	1.70	2.55	3.39	4.25	5.09	—
S34E	2	0.86	1.71	2.56	3.41	4.27	5.13	5.99	0.86	1.71	2.56	3.41	4.26	5.12	5.99
S34E	3	0.86	1.71	2.57	3.42	4.28	5.13	5.99	0.86	1.71	2.57	3.42	4.28	5.13	6.00
S34E	4	0.86	1.71	2.57	3.42	4.28	5.13	5.99	0.86	1.71	2.57	3.42	4.28	5.13	6.00
S34E	5	0.86	1.71	2.56	3.41	4.27	5.13	5.99	0.86	1.71	2.56	3.41	4.26	5.13	5.96
S34E	6	0.86	1.71	2.57	3.41	4.27	5.13	5.99	0.86	1.71	2.57	3.41	4.27	5.13	5.97
S34E	7	0.86	1.71	2.57	3.41	4.27	5.13	5.99	0.86	1.71	2.56	3.41	4.29	5.13	5.96

Cable	Run	Box 1							Box 2						
		1	2	3	4	5	6	7	1	2	3	4	5	6	7
S34E	8*	—	—	—	—	—	—	—	—	—	—	—	—	—	—
S33E	1	0.94	1.89	—	3.74	4.72	5.66	6.61	0.94	1.89	2.83	3.77	4.72	5.66	6.61
S33E	2	0.94	1.89	—	3.77	4.72	5.66	6.61	0.94	1.89	2.83	3.77	4.72	5.66	6.61
S33E	3	0.94	1.89	2.18	3.77	4.72	5.66	6.59	0.94	1.89	2.83	3.77	4.71	5.66	6.60
S33E	4	0.94	1.89	—	3.77	4.72	5.65	6.61	0.94	1.89	2.83	3.77	4.72	5.66	6.66
S33E	5*	—	—	—	—	—	—	—	—	—	—	—	—	—	—
S33E	6	0.94	1.87	2.82	3.72	4.75	5.64	6.57	0.94	1.87	2.82	3.72	—	5.59	6.57
S33E	7	0.94	1.87	—	3.71	4.76	—	6.56	0.94	1.87	2.80	3.71	—	5.60	—
S32E	1	0.99	1.98	2.97	3.96	4.96	5.94	6.92	0.99	1.98	2.97	3.77	4.95	5.94	6.93
S32E	2*	—	—	—	—	—	—	—	—	—	—	—	—	—	—
S32E	3	0.99	1.98	2.97	3.97	—	—	6.95	0.99	1.98	2.97	3.77	—	—	6.95
S32E	4	0.99	1.97	2.96	3.97	—	—	6.92	0.99	1.97	2.97	3.94	—	—	—
S32E	5	0.99	1.97	2.95	3.97	—	—	6.92	0.99	1.97	2.97	3.97	—	—	6.92
S32E	6	0.99	1.98	2.96	3.93	—	—	6.90	0.99	1.98	2.97	3.77	—	—	—
S32E	7	0.99	1.97	2.96	3.94	4.99	5.95	6.93	0.99	1.97	2.97	3.94	4.95	5.94	6.93
S34W	1*	—	—	—	—	—	—	—	—	—	—	—	—	—	—
S34W	2	0.89	1.76	—	3.54	4.43	5.32	6.20	0.89	1.76	2.65	3.54	4.43	5.31	6.19
S34W	3	0.89	1.76	2.66	3.54	4.43	5.32	—	0.89	1.76	2.66	3.54	4.43	5.31	6.09
S34W	4	0.89	1.76	—	3.54	4.43	5.32	6.08	0.89	1.76	2.66	3.54	4.43	5.31	6.08
S34W	5	0.89	1.76	—	3.54	4.43	5.32	6.12	0.89	1.76	2.66	3.54	4.43	5.31	6.12
S34W	6	—	—	—	—	—	—	—	0.89	1.77	2.65	3.54	4.42	5.31	6.05
S34W	7	0.89	1.76	2.66	3.54	4.43	5.31	6.19	0.89	1.76	2.66	3.54	4.43	5.31	6.19
S34W	8	0.89	1.76	2.66	3.54	4.42	5.31	—	0.89	1.76	2.66	3.54	4.43	5.31	6.19
S33W	1*	—	—	—	—	—	—	—	—	—	—	—	—	—	—
S33W	2	0.91	1.81	—	3.64	4.49	—	6.20	0.91	1.81	2.70	3.64	4.49	5.36	6.20
S33W	3	0.91	1.81	—	3.64	4.47	5.45	6.21	0.91	1.81	2.69	3.64	4.54	5.30	6.23
S33W	4	0.91	1.81	—	3.64	4.49	5.35	6.34	0.91	1.81	2.70	3.64	4.49	5.35	6.24
S33W	5	0.91	1.81	2.72	3.64	4.52	5.35	6.35	0.91	1.81	2.72	3.64	4.54	5.32	6.21
S33W	6	0.91	1.81	2.72	3.64	4.54	5.36	6.21	0.91	1.81	2.72	3.64	4.48	5.37	6.23
S33W	7	0.91	1.81	2.72	3.63	4.53	—	6.35	0.91	1.81	2.69	3.64	4.54	5.34	6.23

Cable	Run	Box 1							Box 2						
		1	2	3	4	5	6	7	1	2	3	4	5	6	7
S32W	1*	—	—	—	—	—	—	—	—	—	—	—	—	—	—
S32W	2	1.01	2.03	3.05	4.06	5.07	6.09	7.10	1.01	2.03	3.05	4.06	5.07	6.09	7.10
S32W	3	1.01	2.03	3.05	4.06	5.07	6.09	7.10	1.01	2.03	3.05	4.06	5.06	6.08	7.11
S32W	4	1.01	2.03	3.04	4.06	5.07	6.09	7.10	1.01	2.03	3.05	4.06	5.07	6.09	7.10
S32W	5	1.01	2.03	3.05	4.06	5.07	6.09	7.10	1.01	2.03	3.05	4.06	5.07	6.08	7.10
S32W	6	1.01	2.03	3.04	4.06	5.07	6.09	7.10	1.01	2.03	3.05	4.06	5.07	6.09	7.10
S32W	7	1.01	2.03	3.04	4.06	5.07	6.09	7.09	1.01	2.03	3.04	4.06	5.07	6.09	7.09

*Baseline run.

**Box 2 has corrupt z-axis data, frequencies measured from x-axis data.

—No data available.

Table 9. Phase 1 averaged mode frequencies (Hz).

Cable	1	2	3	4	5	6	7
N01	1.11	2.22	3.33	4.43	5.54	6.65	7.75
N02	1.16	2.33	3.48	4.64	5.80	6.96	8.13
N03	1.29	2.59	3.89	5.19	6.49	7.79	9.11
N34E	0.86	1.71	2.58	3.44	4.28	—	5.98
N33E	0.89	1.76	2.66	3.54	4.43	5.31	6.18
N32E	0.96	1.92	2.88	3.83	4.80	5.76	6.73
N34W	0.86	1.71	2.58	3.44	4.27	5.16	5.96
N33W	0.90	1.79	2.68	3.57	4.48	5.37	6.26
N32W	0.93	1.86	2.78	3.70	4.64	5.44	6.31
S01	1.07	2.13	3.22	4.29	5.37	6.43	7.46
S02	1.11	2.22	3.34	4.45	5.57	6.68	7.79
S03	1.21	2.42	3.63	4.82	6.03	7.25	8.46
S34E	0.86	1.71	2.57	3.41	4.27	5.13	5.99
S33E	0.94	1.89	2.83	3.77	4.72	5.66	6.61
S32E	0.99	1.97	2.97	3.97	4.96	5.94	6.93
S34W	0.89	1.76	2.66	3.54	4.43	5.31	6.19
S33W	0.91	1.81	2.72	3.64	4.49	5.35	6.23
S32W	1.01	2.03	3.05	4.06	5.07	6.09	7.10

—No data available.

Table 10. Phase 2 mode frequencies (Hz).

Cable	Run	Box 1							Box 2						
		1	2	3	4	5	6	7	1	2	3	4	5	6	7
N01	1*	—	—	—	—	—	—	—	—	—	—	—	—	—	—
N01	2	1.21	2.42	3.64	4.86	6.04	7.26	8.47	1.21	2.42	3.64	4.86	6.07	7.23	8.46
N01	3	1.21	2.42	3.64	4.86	6.04	7.26	8.48	1.21	2.42	3.64	4.86	6.06	7.24	8.46
N01	4	1.21	2.42	3.64	4.83	6.04	7.26	8.48	1.21	2.42	3.64	4.86	6.04	7.24	8.46
N01	5	1.21	2.42	3.64	4.83	6.04	7.26	8.48	1.21	2.42	3.64	4.83	6.04	7.28	8.45
N01	6	1.21	2.42	3.64	4.83	6.04	7.26	8.52	1.21	2.42	3.64	4.83	6.04	7.24	8.47
N01	7	1.21	2.42	3.64	4.83	6.04	7.26	8.48	1.21	2.42	3.64	4.86	6.04	7.24	8.48
N01	8	1.21	2.42	3.64	4.86	6.04	7.26	—	1.21	2.42	3.64	4.86	6.04	7.28	—
N01	9	1.21	2.42	3.64	4.86	6.07	7.29	8.48	1.21	2.42	3.64	4.86	6.07	—	—
N02	1*	—	—	—	—	—	—	—	—	—	—	—	—	—	—
N02	2	1.27	2.53	3.81	5.07	6.34	—	—	1.27	2.53	3.81	5.07	6.34	—	—
N02	3	1.27	2.57	3.81	5.05	6.34	7.59	—	1.27	2.57	3.81	5.05	6.34	—	—
N02	4	1.27	2.53	3.81	5.09	6.36	—	—	1.27	2.53	3.81	5.05	6.35	—	—
N02	5	1.27	2.53	3.81	5.07	6.35	—	—	1.27	2.53	3.81	5.07	6.35	—	—
N02	6	1.27	2.53	3.81	5.08	6.36	—	—	1.27	2.53	3.81	5.08	6.36	—	—
N02	7	1.27	2.53	3.81	5.07	6.34	—	—	1.27	2.53	3.81	5.05	6.35	—	—
N02	8	1.27	2.53	3.81	5.07	6.34	—	—	1.27	2.53	3.81	5.07	6.35	—	—
N02	9	1.27	2.53	3.81	5.07	6.35	—	—	1.27	2.53	3.81	5.07	6.34	—	—
N03	1*	—	—	—	—	—	—	—	—	—	—	—	—	—	—
N03	2	1.42	2.82	—	—	—	—	—	1.42	2.82	4.24	5.65	—	—	—
N03	3	1.42	2.81	4.22	5.64	7.03	—	—	1.42	2.81	4.22	5.64	—	—	—
N03	4	1.42	2.81	4.20	5.62	7.03	—	—	1.42	2.81	4.20	5.62	7.03	—	—
N03	5	1.42	2.81	4.22	5.64	7.03	—	—	1.42	2.81	4.22	5.64	—	—	—
N03	6	1.42	2.82	4.22	5.64	7.04	—	—	1.42	2.82	4.22	5.64	—	—	—
N34E	1*	—	—	—	—	—	—	—	—	—	—	—	—	—	—
N34E	2	1.04	2.08	3.11	4.15	5.18	6.20	7.21	1.04	2.08	3.11	4.15	5.18	6.21	—
N34E	3	1.04	2.08	3.11	4.14	5.18	6.23	7.24	1.04	2.08	3.11	4.14	5.18	6.21	7.26
N34E	4	1.04	2.08	3.10	4.14	5.16	—	—	1.04	2.08	3.10	4.14	5.16	—	—
N34E	5	1.04	2.08	3.10	4.14	5.18	—	—	1.04	2.08	3.10	4.14	5.16	—	—

Cable	Run	Box 1							Box 2						
		1	2	3	4	5	6	7	1	2	3	4	5	6	7
N34E	6	1.04	2.08	3.11	4.14	5.16	—	7.20	1.04	2.08	3.11	4.14	5.16	6.20	—
N34E	7	1.04	2.06	3.10	4.13	5.15	—	—	1.04	2.06	3.10	4.13	5.15	6.19	—
N34E	8	1.04	2.06	3.10	4.14	5.16	—	—	1.04	2.06	3.10	4.14	5.15	—	—
N34E	9	1.04	2.06	3.10	4.13	5.15	—	—	1.04	2.06	3.10	4.13	5.15	—	7.51
N33E	1*	—	—	—	—	—	—	—	—	—	—	—	—	—	—
N33E	2	1.04	2.06	3.10	4.11	5.18	—	—	1.04	2.06	3.10	4.11	5.18	—	—
N33E	3	1.04	2.06	3.10	4.14	5.18	—	—	1.04	2.06	3.10	4.14	5.18	—	—
N33E	4	1.04	2.06	3.09	4.14	5.16	—	—	1.04	2.06	3.09	4.14	5.16	6.19	—
N33E	5	1.04	2.06	3.10	4.14	5.18	6.21	—	1.04	2.06	3.10	4.14	5.18	—	—
N33E	6	1.04	2.06	3.09	4.11	5.16	6.19	7.18	1.04	2.06	3.09	4.11	5.18	6.20	—
N33E	7	1.04	2.06	3.09	4.11	5.14	—	—	1.04	2.06	3.09	4.11	5.14	—	—
N33E	8	1.04	2.06	3.09	4.14	5.16	—	7.15	1.04	2.06	3.09	4.14	5.16	—	—
N33E	9	1.04	2.06	3.09	4.11	5.16	—	—	1.04	2.06	3.09	4.11	5.16	—	—
N32E	1*	—	—	—	—	—	—	—	—	—	—	—	—	—	—
N32E	2	1.09	2.16	3.25	4.31	5.40	—	—	1.09	2.16	3.25	4.32	5.40	6.51	—
N32E	3	1.09	2.16	3.25	4.30	5.38	—	—	1.09	2.16	3.25	4.30	5.38	—	—
N32E	4	1.09	2.16	3.26	4.30	5.40	—	—	1.09	2.16	3.25	4.31	5.40	—	—
N32E	5	1.09	2.16	3.25	4.32	5.40	—	—	1.09	2.16	3.25	4.33	5.40	—	—
N32E	6	1.09	2.16	3.25	4.33	5.42	—	—	1.09	2.16	3.25	4.33	5.42	—	—
N32E	7	1.09	2.16	3.25	4.30	5.38	—	—	1.09	2.16	3.25	4.33	5.38	—	—
N32E	8	1.09	2.16	3.26	4.30	5.42	—	—	1.09	2.16	3.25	4.30	5.42	—	—
N32E	9	1.09	2.17	3.25	4.30	5.39	—	—	1.09	2.17	3.25	4.33	5.42	—	—
N34W	1*	—	—	—	—	—	—	—	—	—	—	—	—	—	—
N34W	2	0.96	1.93	2.89	3.85	4.81	5.74	6.74	0.96	1.93	2.89	3.85	4.81	5.75	—
N34W	3	0.98	1.93	2.91	3.83	4.81	5.71	—	0.98	1.93	2.88	3.83	4.81	—	—
N34W	4	0.96	1.93	2.89	3.86	4.80	5.80	—	0.96	1.93	2.89	3.86	4.83	5.79	—
N34W	5	0.98	1.93	2.91	3.86	4.79	5.79	—	0.98	1.93	2.91	3.83	4.81	—	—
N34W	6	0.96	1.93	2.89	3.86	4.81	—	—	0.96	1.93	2.89	3.86	4.81	—	—
N34W	7	0.96	1.93	2.89	3.85	4.81	—	—	0.96	1.93	2.89	3.85	4.81	—	—
N34W	8*	—	—	—	—	—	—	—	—	—	—	—	—	—	—

Cable	Run	Box 1							Box 2						
		1	2	3	4	5	6	7	1	2	3	4	5	6	7
N34W	9	0.98	1.94	2.91	3.89	4.86	5.84	6.80	0.98	1.94	2.91	3.89	4.86	—	—
N34W	10	0.98	1.94	2.91	3.88	4.82	5.77	6.80	0.98	1.94	2.91	3.88	4.83	—	—
N33W	1*	—	—	—	—	—	—	—	—	—	—	—	—	—	—
N33W	2	1.04	2.08	3.10	4.11	5.15	6.14	7.17	1.04	2.08	3.10	4.11	5.15	6.13	—
N33W	3	1.04	2.08	3.13	4.10	5.15	—	7.17	1.04	2.08	3.10	4.10	5.15	—	—
N33W	4	1.04	2.08	3.10	4.11	5.15	—	—	1.04	2.08	3.10	4.11	5.15	6.13	—
N33W	5	1.04	2.08	3.10	4.11	5.18	—	7.18	1.04	2.08	3.10	4.11	5.18	6.12	—
N33W	6	1.04	2.08	3.10	4.11	5.13	—	—	1.04	2.08	3.10	4.11	5.13	6.17	—
N33W	7	1.04	2.08	3.10	4.11	5.16	6.15	—	1.04	2.08	3.10	4.11	5.16	6.15	—
N33W	8	1.04	2.08	3.17	4.11	5.14	—	—	1.04	2.08	3.09	4.11	5.13	—	—
N33W	9	1.04	2.08	3.11	4.14	5.16	—	7.20	1.04	2.08	3.11	4.14	5.16	—	—
N32W	1*	—	—	—	—	—	—	—	—	—	—	—	—	—	—
N32W	2	1.05	2.09	3.14	4.19	5.24	6.29	7.31	1.05	2.10	3.14	4.19	5.24	6.29	7.32
N32W	3	1.05	2.10	3.14	4.19	5.24	6.29	—	1.05	2.10	3.14	4.19	5.23	6.29	7.32
N32W	4	1.05	2.10	3.14	4.19	5.24	6.29	7.34	1.05	2.10	3.14	4.19	5.24	6.29	7.34
N32W	5	1.05	2.10	3.14	4.19	5.24	6.26	7.30	1.05	2.09	3.14	4.19	5.23	6.29	7.32
N32W	6	1.05	2.09	3.14	4.18	5.25	6.29	7.31	1.05	2.09	3.14	4.18	5.25	6.29	7.32
N32W	7	1.05	2.10	3.14	4.19	5.23	—	—	1.05	2.10	3.14	4.19	5.23	6.29	7.32
N32W	8	1.05	2.09	3.14	4.19	5.24	—	7.32	1.05	2.09	3.14	4.19	5.24	—	7.32
N32W	9	1.05	2.09	3.14	4.18	5.21	—	7.17	1.05	2.09	3.14	4.18	5.21	6.27	7.34
S01	1*	—	—	—	—	—	—	—	—	—	—	—	—	—	—
S01	2	1.16	2.32	3.48	4.64	5.82	6.96	8.13	1.16	2.31	3.48	4.64	5.83	6.96	—
S01	3	1.16	2.31	3.48	4.63	5.80	6.95	8.12	1.16	2.31	3.48	4.63	5.80	6.95	8.12
S01	4	1.16	2.31	3.48	4.63	5.79	6.95	8.12	1.16	2.31	3.48	4.63	5.79	6.95	8.11
S01	5	1.16	2.31	3.48	4.63	5.79	6.95	8.12	1.16	2.31	3.48	4.63	5.79	6.95	—
S01	6	1.16	2.31	3.48	4.63	5.79	6.95	8.12	1.16	2.31	3.48	4.63	5.79	6.95	—
S01	7	1.16	2.31	3.49	4.64	5.80	6.96	—	1.16	2.31	3.49	4.64	5.80	—	—
S01	8	1.16	2.31	3.48	4.64	5.80	6.96	8.12	1.16	2.31	3.48	4.64	5.80	6.96	8.12
S01	9	1.16	2.31	3.48	4.63	5.80	6.95	8.12	1.16	2.31	3.48	4.63	5.80	6.95	8.12
S02	1*	—	—	—	—	—	—	—	—	—	—	—	—	—	—

Cable	Run	Box 1							Box 2						
		1	2	3	4	5	6	7	1	2	3	4	5	6	7
S02	2	1.22	2.44	3.67	4.88	6.09	—	8.46	1.22	2.44	3.66	4.88	6.09	—	—
S02	3	1.22	2.44	3.66	4.87	6.07	7.29	8.51	1.22	2.44	3.66	4.87	6.07	—	8.50
S02	4	1.22	2.44	3.66	4.88	6.07	7.30	8.46	1.22	2.44	3.66	4.88	6.07	—	8.51
S02	5	1.22	2.44	3.66	4.87	6.07	7.29	8.51	1.22	2.44	3.66	4.87	6.07	—	8.50
S02	6	1.22	2.44	3.67	4.88	6.08	7.30	8.51	1.22	2.44	3.66	4.88	6.08	—	8.51
S02	7	1.22	2.44	3.67	4.88	6.09	—	8.47	1.22	2.44	3.66	4.88	6.09	—	—
S02	8	1.22	2.44	3.66	4.88	6.06	—	8.51	1.22	2.44	3.66	4.88	6.06	—	8.51
S02	9	1.22	2.44	3.66	4.88	6.08	—	—	1.22	2.44	—	4.87	6.09	—	—
S03	1*	—	—	—	—	—	—	—	—	—	—	—	—	—	—
S03	2	1.33	2.65	3.98	5.31	6.64	—	—	1.33	2.65	3.98	5.31	6.64	—	—
S03	3	1.33	2.65	3.98	5.30	6.63	8.00	—	1.33	2.65	3.98	5.30	6.62	—	—
S03	4	1.33	2.65	3.98	5.30	6.63	—	—	1.33	2.65	3.98	5.30	6.63	—	—
S03	5	1.33	2.65	3.98	5.30	6.64	—	—	1.33	2.65	3.98	5.30	6.65	—	—
S03	6	1.33	2.65	3.98	5.30	6.64	—	—	1.33	2.65	3.98	5.30	6.64	—	—
S03	7	1.33	2.65	3.98	5.30	6.62	—	9.29	1.33	2.65	3.98	5.30	6.62	—	—
S03	8	1.33	2.65	3.98	5.30	6.60	—	9.28	1.33	2.65	3.98	5.30	6.62	—	—
S03	9	1.33	2.65	3.98	5.30	6.62	—	—	1.33	2.65	3.98	5.30	6.62	—	—
S34E	1*	—	—	—	—	—	—	—	—	—	—	—	—	—	—
S34E	2	1.05	2.11	3.16	4.22	5.26	—	—	1.05	2.11	3.16	4.22	5.26	6.34	—
S34E	3	1.05	2.11	3.15	4.22	5.25	—	—	1.05	2.11	3.15	4.22	5.26	6.34	—
S34E	4	1.05	2.11	3.16	4.22	5.26	6.32	—	1.05	2.11	3.15	4.22	5.26	6.32	—
S34E	5	1.05	2.11	3.15	4.22	5.26	6.31	—	1.05	2.11	3.15	4.22	5.26	6.32	—
S34E	6	1.05	2.11	3.15	4.21	5.26	6.32	—	1.05	2.11	3.15	4.21	5.26	6.32	7.36
S34E	7	1.05	2.11	3.16	4.21	5.26	6.32	7.39	1.05	2.11	3.16	4.22	5.26	6.32	—
S34E	8	1.05	2.11	3.15	4.20	5.25	—	—	1.05	2.11	3.15	4.20	5.25	—	—
S34E	9	1.05	2.11	3.15	4.19	5.24	—	—	1.05	2.11	3.15	4.19	5.24	—	—
S33E	1*	—	—	—	—	—	—	—	—	—	—	—	—	—	—
S33E	2	1.10	2.20	3.30	4.40	—	—	—	1.10	2.20	3.30	4.40	5.51	—	—
S33E	3	1.10	2.20	3.31	4.40	5.51	—	—	1.10	2.20	3.30	4.40	5.51	—	—
S33E	4	1.10	2.20	3.31	4.40	—	—	—	1.10	2.20	3.30	4.40	5.51	—	—

Cable	Run	Box 1							Box 2						
		1	2	3	4	5	6	7	1	2	3	4	5	6	7
S33E	5	1.10	2.20	3.28	4.41	5.49	—	—	1.10	2.20	3.28	4.41	5.51	—	—
S33E	6	1.10	2.21	—	4.41	—	—	—	1.10	2.21	3.30	4.41	5.51	—	—
S33E	7	1.10	2.20	3.30	4.40	5.51	—	—	1.10	2.20	3.30	4.41	5.51	—	—
S33E	8	1.10	2.20	3.30	4.40	5.49	—	—	1.10	2.20	3.30	4.40	5.49	—	—
S33E	9	1.10	2.20	—	4.36	—	—	—	1.10	2.20	3.30	4.40	—	—	—
S32E	1*	—	—	—	—	—	—	—	—	—	—	—	—	—	—
S32E	2	1.14	2.27	3.41	4.50	5.68	—	—	1.14	2.27	3.41	4.50	5.68	—	—
S32E	3	1.14	2.27	3.41	4.52	5.69	—	—	1.14	2.27	3.41	4.52	5.68	6.79	—
S32E	4	1.14	2.28	3.43	4.53	5.70	—	—	1.14	2.28	3.42	4.53	5.71	—	—
S32E	5	1.15	2.28	3.43	4.53	5.71	—	—	1.15	2.28	3.43	4.53	5.71	—	—
S32E	6	1.15	2.28	3.43	4.52	5.71	—	—	1.15	2.28	3.43	4.52	5.71	—	—
S32E	7	1.15	2.27	3.42	4.54	5.71	—	—	1.15	2.27	3.42	4.54	5.71	—	—
S32E	8	1.15	2.28	3.43	4.53	5.71	—	—	1.15	2.28	3.43	4.53	5.71	—	—
S32E	9	1.15	2.28	3.43	4.53	5.71	—	—	1.15	2.28	3.43	4.53	5.71	—	—
S34W	1*	—	—	—	—	—	—	—	—	—	—	—	—	—	—
S34W	2	1.01	2.01	—	4.03	5.04	—	7.07	1.01	2.01	3.02	4.03	5.04	—	—
S34W	3	1.01	2.01	—	4.03	5.02	6.04	7.00	1.01	2.01	3.02	4.03	5.02	6.04	—
S34W	4	1.00	2.00	—	4.03	5.03	—	7.03	1.00	2.00	3.00	4.03	5.03	—	—
S34W	5	1.01	2.01	—	4.03	5.03	6.04	7.07	1.01	2.01	3.02	4.03	5.03	—	—
S34W	6	1.01	2.01	—	4.03	4.99	—	7.04	1.01	2.01	3.02	4.03	4.99	—	—
S34W	7	1.01	2.01	—	4.03	5.01	—	7.00	1.01	2.01	3.03	4.03	5.02	—	—
S34W	8	1.00	2.01	3.02	4.00	5.03	—	—	1.01	2.01	3.02	3.99	—	—	—
S34W	9	1.00	2.01	3.00	3.99	—	—	—	1.01	2.01	—	3.99	—	—	—
S33W	1*	—	—	—	—	—	—	—	—	—	—	—	—	—	—
S33W	2	1.04	2.08	3.10	4.11	5.15	6.13	7.17	1.04	2.08	3.10	4.11	5.16	6.13	7.18
S33W	3	1.04	2.08	3.13	4.10	5.15	—	7.17	1.04	2.08	3.10	4.10	5.15	—	—
S33W	4	1.04	2.08	3.10	4.11	5.15	—	—	1.04	2.08	3.10	4.11	5.15	6.13	—
S33W	5	1.04	2.08	3.10	4.11	5.18	—	7.18	1.04	2.08	3.10	4.11	5.18	6.12	—
S33W	6	1.04	2.08	3.10	4.11	5.13	—	—	1.04	2.08	3.10	4.11	5.13	6.17	—
S33W	7	1.04	2.08	3.10	4.11	5.16	6.15	—	1.04	2.08	3.10	4.11	5.16	6.15	—

Cable	Run	Box 1							Box 2						
		1	2	3	4	5	6	7	1	2	3	4	5	6	7
S33W	8	1.04	2.08	3.17	4.11	5.14	—	7.15	1.04	2.08	3.09	4.11	5.13	6.15	—
S33W	9	1.04	2.08	3.11	4.14	5.16	—	—	1.04	2.08	3.11	4.14	5.16	—	—
S32W	1*	—	—	—	—	—	—	—	—	—	—	—	—	—	—
S32W	2	1.14	2.27	—	4.50	5.63	—	—	1.14	2.27	3.41	4.50	5.65	6.71	—
S32W	3	1.14	2.27	—	4.52	5.66	—	—	1.14	2.27	3.41	4.52	5.66	—	—
S32W	4	1.14	2.26	3.39	4.49	5.58	—	—	1.14	2.27	—	—	5.63	—	—
S32W	5	1.14	2.27	—	4.48	5.64	—	—	1.14	2.27	3.41	4.48	5.64	6.74	—
S32W	6	1.14	2.27	—	4.52	5.65	—	—	1.14	2.27	3.41	4.52	5.65	—	—
S32W	7	1.14	2.27	—	4.52	5.64	—	—	1.14	2.27	3.39	4.52	5.64	—	—
S32W	8	1.14	2.27	—	4.50	5.68	—	—	1.14	2.27	3.41	4.50	5.68	—	—
S32W	9	1.12	2.27	—	4.52	5.69	—	—	1.12	2.27	3.39	4.49	5.64	—	—

*Baseline run.

—No data available.

Table 11. Phase 2 averaged mode frequencies (Hz).

Cable	1	2	3	4	5	6	7
N01	1.21	2.42	3.64	4.86	6.04	7.26	8.47
N02	1.27	2.53	3.81	5.07	6.34	7.59	—
N03	1.42	2.81	4.22	5.64	7.03	—	—
N34E	1.04	2.08	3.10	4.14	5.18	6.20	7.21
N33E	1.04	2.06	3.09	4.11	5.16	6.19	7.18
N32E	1.09	2.16	3.25	4.30	5.40	6.51	—
N34W	1.05	2.11	3.15	4.22	5.26	6.32	7.39
N33W	1.10	2.20	3.30	4.40	5.51	—	—
N32W	1.15	2.28	3.43	4.53	5.71	6.79	—
S01	0.96	1.93	2.89	3.86	4.81	5.79	6.78
S02	1.04	2.08	3.10	4.11	5.15	6.14	7.17
S03	1.05	2.10	3.14	4.19	5.24	6.29	7.32
S34E	1.01	2.01	3.02	4.03	5.04	6.04	7.04
S33E	1.04	2.08	3.10	4.11	5.16	6.13	7.17
S32E	1.14	2.27	3.41	4.50	5.64	6.71	—
S34W	1.16	2.31	3.48	4.63	5.79	6.95	8.12
S33W	1.22	2.44	3.66	4.88	6.08	7.29	8.51
S32W	1.33	2.65	3.98	5.30	6.64	8.00	9.29

—No data available.

Table 12. Phase 3 mode frequencies (Hz).

Cable	Run	Box 1							Box 2						
		1	2	3	4	5	6	7	1	2	3	4	5	6	7
N01	1*	—	—	—	—	—	—	—	—	—	—	—	—	—	—
N01	2	3.81	7.52	—	—	—	—	—	3.81	—	—	—	—	—	—
N01	3	3.13	—	—	—	—	—	—	2.93	—	—	—	—	—	—
N01	4	2.93	—	—	—	—	—	—	2.93	—	—	—	—	—	—
N01	5	2.93	—	—	—	—	—	—	2.93	—	—	—	—	—	—
N01	6	2.93	—	—	—	—	—	—	2.93	—	—	—	—	—	—
N01	7	2.93	—	—	—	—	—	—	3.91	—	—	—	—	—	—
N01	8	3.91	—	—	—	—	—	—	3.91	—	—	—	—	—	—
N01	9	2.93	—	—	—	—	—	—	2.93	—	—	—	—	—	—
N02	1*	—	—	—	—	—	—	—	—	—	—	—	—	—	—
N02	2	2.93	—	—	—	—	—	—	2.93	—	—	—	—	—	—
N02	3	2.93	—	—	—	—	—	—	2.93	—	—	—	—	—	—
N02	4	4.30	—	—	—	—	—	—	4.30	—	—	—	—	—	—
N02	5	2.93	4.88	9.0	—	—	—	—	2.93	4.88	—	—	—	—	—
N02	6	2.93	—	9.0	—	—	—	—	2.93	—	—	—	—	—	—
N02	7	2.93	—	9.0	12.7	—	—	—	2.93	—	—	12.7	—	—	—
N02	8	2.93	—	9.0	—	—	—	—	4.30	—	—	12.7	—	—	—
N02	9	—	—	—	—	—	—	—	—	—	—	—	—	—	—
N03	1*	—	—	—	—	—	—	—	—	—	—	—	—	—	—
N03	2	5.08	—	—	—	—	—	—	5.08	—	—	—	—	—	—
N03	3	5.27	10.94	—	—	—	—	—	5.27	—	—	—	—	—	—
N03	4	4.88	—	—	—	—	—	—	5.08	—	—	—	—	—	—
N03	5	5.66	—	—	—	—	—	—	5.66	—	—	—	—	—	—
N03	6	5.27	—	—	—	—	—	—	5.27	—	—	—	—	—	—
N03	7	4.88	—	—	—	—	—	—	4.88	—	—	—	—	—	—
N03	8	4.88	—	—	—	—	—	—	4.88	—	—	—	—	—	—
N03	9	5.08	—	—	—	—	—	—	5.08	—	—	—	—	—	—
N34E	1*	—	—	—	—	—	—	—	—	—	—	—	—	—	—
N34E	2	2.15	4.30	6.5	8.6	10.7	12.9	15.0	2.15	4.30	6.5	8.6	10.7	—	—

Cable	Run	Box 1							Box 2						
		1	2	3	4	5	6	7	1	2	3	4	5	6	7
N34E	3	2.15	4.30	6.5	8.6	10.7	12.9	15.0	2.15	4.30	6.5	8.6	10.7	12.9	15.0
N34E	4	2.15	4.30	6.5	8.6	10.7	12.9	15.0	2.15	4.30	6.5	8.6	10.7	12.9	15.0
N34E	5	2.15	4.30	6.5	8.6	10.7	12.9	15.0	2.15	4.30	6.5	8.6	10.7	12.9	15.0
N34E	6	2.15	4.30	6.5	8.6	10.7	12.9	14.8	2.15	4.30	6.5	8.6	10.7	12.9	15.0
N34E	7	2.15	4.30	6.5	8.6	10.7	12.9	15.0	2.15	4.30	6.5	8.6	10.7	12.9	15.0
N34E	8	2.15	4.30	6.5	8.5	10.7	12.9	14.9	2.15	4.30	6.5	8.5	10.7	12.9	15.0
N34E	9	2.15	4.30	6.5	8.5	10.7	12.9	15.0	2.15	4.30	6.5	8.5	10.7	12.8	15.0
N33E	1*	—	—	—	—	—	—	—	—	—	—	—	—	—	—
N33E	2	2.34	4.69	7.4	9.6	12.1	14.5	—	2.34	4.69	7.4	9.6	12.1	—	—
N33E	3	2.34	4.88	7.4	9.6	11.9	14.3	16.8	2.34	4.88	7.0	9.6	11.9	—	17.0
N33E	4	2.34	4.88	7.4	9.6	12.1	14.3	16.8	2.34	4.69	7.4	9.6	12.1	—	16.8
N33E	5	2.34	5.08	7.4	10.2	12.1	14.5	17.2	2.34	4.49	7.4	10.2	12.1	—	16.8
N33E	6	2.34	4.98	7.4	9.4	11.9	14.5	17.2	2.34	4.79	7.2	—	11.9	—	16.5
N33E	7	2.34	4.79	7.4	9.6	11.9	14.2	—	2.34	4.69	7.4	9.6	11.9	—	—
N33E	8	2.34	4.69	7.2	9.4	11.9	14.3	16.4	2.34	4.69	7.2	9.4	11.9	—	16.6
N33E	9	2.34	4.69	7.4	9.6	11.9	14.3	16.4	2.34	4.69	7.4	9.6	11.9	—	—
N32E	1*	—	—	—	—	—	—	—	—	—	—	—	—	—	—
N32E	2	2.73	5.57	8.2	—	13.6	16.2	19.0	2.73	5.47	8.2	—	13.5	—	—
N32E	3	2.73	5.66	8.4	—	13.7	16.2	—	2.73	5.47	8.4	10.9	13.7	—	—
N32E	4	2.73	5.57	—	—	—	—	—	2.73	5.57	8.5	—	—	—	—
N32E	5	2.73	5.57	8.1	—	—	16.2	19.1	2.73	5.37	8.0	—	13.6	—	—
N32E	6	2.73	5.57	8.2	—	13.7	16.2	18.9	2.73	5.37	8.0	—	13.5	—	19.0
N32E	7	2.73	5.57	8.3	—	13.6	16.2	18.5	2.73	5.57	8.3	10.9	13.6	—	18.5
N32E	8	2.73	5.57	8.3	—	13.6	16.2	—	2.73	5.57	8.3	11.2	13.6	—	—
N32E	9	2.73	5.27	8.2	11.1	13.5	15.8	19.3	2.73	5.66	8.2	10.9	13.7	16.6	19.3
N34W	1*	—	—	—	—	—	—	—	—	—	—	—	—	—	—
N34W	2	2.15	4.32	6.5	—	—	12.9	—	2.15	4.32	6.5	8.6	10.7	—	—
N34W	3	2.15	4.32	6.5	8.6	10.8	—	—	2.15	4.32	6.5	8.6	10.8	—	—
N34W	4	2.15	4.30	6.5	8.6	10.7	12.8	14.9	2.15	4.30	6.5	8.6	10.7	12.9	14.8
N34W	4**	2.15	4.30	6.5	8.6	10.6	12.6	—	2.15	4.28	6.3	8.6	10.6	12.5	14.8

Cable	Run	Box 1							Box 2						
		1	2	3	4	5	6	7	1	2	3	4	5	6	7
N34W	5	2.15	4.32	6.5	8.6	10.7	12.9	—	2.15	4.32	6.5	8.6	10.7	—	—
N34W	6	2.15	4.32	6.5	8.6	10.7	12.9	15.0	2.15	4.30	6.5	8.6	10.7	—	—
N34W	7	2.15	4.32	6.5	8.6	10.8	13.0	15.1	2.15	4.32	6.5	8.6	10.8	12.9	15.1
N34W	8	2.15	4.32	6.5	8.6	10.6	12.8	15.4	2.15	4.32	6.5	8.6	10.8	12.8	—
N34W	9	2.15	4.31	6.5	8.7	10.7	12.8	15.1	2.15	4.31	6.4	8.6	10.7	12.8	—
N33W	1*	—	—	—	—	—	—	—	—	—	—	—	—	—	—
N33W	2	2.39	4.66	7.2	—	—	—	—	2.39	4.64	7.2	9.7	11.9	—	—
N33W	3	2.39	4.66	7.2	—	—	—	—	2.39	4.64	7.2	—	—	—	—
N33W	4	2.39	4.66	7.2	—	—	—	—	2.39	4.64	7.2	9.6	11.9	—	—
N33W	5	2.39	4.66	7.2	—	—	—	—	2.39	4.64	7.2	—	—	—	—
N33W	6	2.39	4.66	7.2	—	—	—	—	2.39	4.64	7.2	—	11.9	—	—
N33W	7	2.39	4.66	7.2	—	11.9	—	—	2.39	4.66	7.2	—	11.9	—	—
N33W	8	2.39	4.64	7.2	—	—	—	—	2.39	4.64	7.2	—	11.9	—	—
N33W	9	2.39	4.66	7.2	—	—	—	—	2.39	4.66	7.2	—	11.9	—	—
N32W	1*	—	—	—	—	—	—	—	—	—	—	—	—	—	—
N32W	2	2.64	5.37	8.2	—	—	—	—	2.64	—	8.1	—	—	—	—
N32W	3	2.64	5.23	8.0	—	—	—	—	2.64	5.23	7.8	10.5	—	—	—
N32W	4	2.64	5.23	8.0	10.6	13.2	—	—	2.64	5.30	7.9	10.6	13.1	—	—
N32W	5	2.64	5.30	7.9	10.6	13.3	—	—	2.64	5.23	7.8	10.5	13.1	—	—
N32W	6	—	—	—	—	—	—	—	—	—	—	—	—	—	—
N32W	7	—	—	—	—	—	—	—	—	—	—	—	—	—	—
N32W	8	2.61	5.20	7.6	10.1	12.7	—	—	2.61	5.18	7.6	10.5	—	—	—
N32W	9	2.61	5.23	7.9	10.6	12.7	—	—	2.61	5.27	7.6	10.5	12.9	—	—
S01	1*	—	—	—	—	—	—	—	—	—	—	—	—	—	—
S01	2	3.52	7.03	—	—	—	—	—	3.52	—	10.5	—	—	—	—
S01	3	3.52	7.03	10.5	14.0	17.4	21.2	24.4	3.52	7.03	10.5	14.0	17.4	20.9	24.4
S01	4	3.52	7.03	10.5	14.0	17.4	—	—	3.52	7.03	10.4	14.0	17.4	21.0	24.4
S01	5	3.52	7.03	10.5	14.0	17.4	—	—	3.52	7.03	10.4	14.0	17.4	21.0	—
S01	6	3.52	7.03	—	14.2	—	—	—	3.52	7.03	10.6	14.2	—	—	—
S01	7	3.52	7.03	10.5	14.0	17.4	21.1	24.5	3.52	7.03	10.4	14.0	17.4	21.0	24.4

Cable	Run	Box 1							Box 2						
		1	2	3	4	5	6	7	1	2	3	4	5	6	7
S01	8	3.52	7.03	10.5	14.1	17.4	21.0	24.6	3.52	7.03	10.5	14.1	17.5	21.1	24.6
S01	9	3.52	—	—	—	—	—	—	3.52	—	—	—	—	—	—
S02	1*	—	—	—	—	—	—	—	—	—	—	—	—	—	—
S02	2	3.91	7.62	11.3	14.8	18.6	22.1	26.0	3.91	—	11.1	—	18.6	22.1	—
S02	3	3.91	7.62	11.	—	—	—	—	3.91	—	11.5	15.4	19.3	—	—
S02	4	3.91	7.62	—	—	—	—	—	3.91	—	—	—	—	—	—
S02	5	3.91	7.81	—	—	—	—	—	3.91	—	—	—	—	—	—
S02	6	3.91	7.62	11.3	15.0	—	—	—	3.91	7.62	11.3	15.2	—	—	—
S02	7	3.91	8.40	—	—	—	—	—	3.91	8.40	—	—	—	—	—
S02	8	3.91	7.81	11.5	15.0	—	—	—	3.91	8.40	11.5	—	—	—	—
S02	9	3.91	7.62	11.5	—	—	—	—	3.91	8.40	11.5	15.2	19.3	—	—
S03	1*	—	—	—	—	—	—	—	—	—	—	—	—	—	—
S03	2	4.30	8.89	14.1	—	—	—	—	4.30	—	14.1	—	—	—	—
S03	3	4.30	8.89	—	—	—	—	—	4.30	8.98	—	—	—	—	—
S03	4	4.49	9.38	—	—	—	—	—	4.49	9.38	—	—	—	—	—
S03	5	4.98	9.38	—	—	—	—	—	4.98	—	—	—	—	—	—
S03	6	4.88	9.38	—	—	—	—	—	4.88	—	13.9	—	—	—	—
S03	7	4.88	—	—	—	—	—	—	4.88	—	—	—	—	—	—
S03	8	4.49	8.98	—	—	—	—	—	4.49	—	—	—	—	—	—
S34E	1*	—	—	—	—	—	—	—	—	—	—	—	—	—	—
S34E	2	2.34	4.59	6.9	9.2	11.6	13.8	16.3	2.34	4.59	6.9	9.3	11.6	13.9	16.2
S34E	3	2.34	4.59	6.8	9.0	11.6	13.8	16.2	2.34	4.59	6.8	9.1	11.5	13.9	16.2
S34E	4	2.34	4.59	6.9	9.1	11.6	13.8	16.1	2.34	4.59	6.9	9.1	11.6	13.8	16.2
S34E	5	2.34	4.59	6.9	9.2	11.6	13.8	16.1	2.34	4.59	6.8	9.4	11.6	13.9	16.1
S34E	6	2.34	4.59	6.9	9.1	11.7	13.8	16.3	2.34	4.59	6.9	9.0	11.6	13.8	16.3
S34E	7	2.34	4.59	6.9	9.2	11.5	13.8	16.1	2.34	4.59	6.9	9.1	11.5	13.8	16.1
S34E	8	2.34	4.59	6.9	9.2	11.6	13.9	16.4	2.34	4.59	6.9	9.3	11.6	13.9	16.2
S34E	9	2.34	4.59	6.9	9.2	11.6	13.9	16.1	2.34	4.59	6.9	9.2	11.6	13.9	16.1
S33E	1*	—	—	—	—	—	—	—	—	—	—	—	—	—	—
S33E	2	2.54	5.18	7.9	10.4	—	—	—	2.54	5.18	7.9	—	—	—	—

Cable	Run	Box 1							Box 2						
		1	2	3	4	5	6	7	1	2	3	4	5	6	7
S33E	3	2.73	5.27	8.0	—	—	—	—	2.73	5.27	8.0	10.7	—	—	—
S33E	4	2.83	5.57	—	—	—	—	—	2.83	5.57	—	—	—	—	—
S33E	5	2.54	5.18	7.9	10.3	13.2	15.6	18.3	2.54	5.18	7.9	10.6	13.1	—	—
S33E	6	2.54	5.18	7.	10.4	13.2	15.4	18.3	2.54	5.18	7.9	10.5	13.1	—	—
S33E	7	2.64	5.18	7.91	10.6	13.2	15.7	18.3	2.64	5.18	7.9	10.6	13.2	—	—
S33E	8	2.54	5.37	7.9	—	—	—	—	2.54	5.18	7.9	—	—	—	—
S33E	9	2.64	5.18	8.0	—	—	—	—	2.64	5.18	8.0	—	—	—	—
S32E	1*	—	—	—	—	—	—	—	—	—	—	—	—	—	—
S32E	2	2.73	5.66	8.6	—	—	—	—	2.73	5.66	8.4	11.3	14.3	—	—
S32E	3	2.83	5.66	8.8	11.6	—	—	—	2.83	5.66	8.4	11.5	14.2	17.2	—
S32E	4	3.03	5.86	9.0	—	—	—	—	3.03	6.06	9.0	—	—	17.9	—
S32E	5	2.73	5.86	8.8	—	—	—	—	2.73	5.66	8.2	—	—	—	—
S32E	6	2.73	5.66	8.6	—	—	—	—	2.73	5.66	8.4	—	—	—	—
S32E	7	2.83	5.86	9.0	—	—	—	—	3.13	5.96	9.0	—	—	—	—
S32E	8	2.93	5.86	8.6	—	—	—	—	2.93	5.86	8.8	11.5	14.3	—	—
S32E	9^	—	—	—	—	—	—	—	—	—	—	—	—	—	—
S34W	1*	—	—	—	—	—	—	—	—	—	—	—	—	—	—
S34W	2	2.25	4.40	6.5	8.7	11.0	13.4	15.3	2.25	4.40	6.5	8.9	10.9	13.3	15.4
S34W	3	2.25	4.40	6.5	8.8	11.0	13.4	15.4	2.25	4.40	6.5	8.9	11.0	13.1	15.6
S34W	4	2.25	4.40	6.5	8.7	10.9	13.4	15.6	2.25	4.40	6.5	8.9	11.0	13.1	15.6
S34W	5	2.25	4.40	6.6	—	11.1	13.2	—	2.25	4.40	6.6	8.9	11.1	13.1	15.5
S34W	6	2.25	4.40	6.6	—	10.9	13.2	15.5	2.25	4.49	6.6	8.9	11.1	13.3	15.5
S34W	7	2.25	4.40	6.6	9.0	11.1	13.3	15.5	2.15	4.40	6.6	8.9	11.0	13.2	15.2
S34W	8	2.15	4.40	6.6	8.8	11.1	13.3	15.5	2.05	4.40	6.6	8.9	11.0	13.3	15.3
S34W	9	2.25	4.40	6.6	8.9	11.1	13.3	15.5	2.05	4.40	6.6	8.8	11.1	13.3	15.5
S33W	1*	—	—	—	—	—	—	—	—	—	—	—	—	—	—
S33W	2	2.44	4.79	7.3	9.8	12.3	14.8	17.3	2.44	4.79	7.3	9.9	12.2	—	—
S33W	3	2.44	4.79	7.4	9.9	12.3	14.7	17.3	2.44	4.98	7.4	9.8	12.3	14.8	17.4
S33W	4	2.44	4.79	7.3	10.2	12.5	14.7	17.3	2.44	4.88	7.3	—	12.2	14.8	17.0
S33W	5	2.44	4.79	7.3	9.9	12.2	14.7	17.2	2.44	4.88	7.3	9.6	12.2	14.7	17.1

Cable	Run	Box 1							Box 2						
		1	2	3	4	5	6	7	1	2	3	4	5	6	7
S33W	6	2.44	4.79	7.3	9.9	12.3	14.7	17.2	2.44	4.98	7.3	9.8	12.2	14.7	17.1
S33W	7	2.44	4.79	7.3	10.0	12.3	14.7	17.2	2.44	4.98	7.4	9.9	12.2	14.8	17.1
S33W	8	2.44	4.79	7.3	9.9	12.2	14.5	—	2.44	4.88	7.3	9.6	12.3	14.6	—
S33W	9	2.44	4.79	7.3	10.0	12.0	14.7	17.2	2.44	4.98	7.3	9.9	12.2	14.7	17.0
S32W	1*	—	—	—	—	—	—	—	—	—	—	—	—	—	—
S32W	2	2.73	5.66	8.6	11.1	13.5	—	—	2.73	5.47	8.6	—	13.7	—	—
S32W	3	2.83	5.57	8.4	11.3	14.1	16.8	19.2	2.83	5.57	8.3	11.1	13.9	16.7	19.4
S32W	4	2.83	5.57	8.4	11.3	14.0	16.9	19.2	2.83	5.47	8.4	11.2	14.2	16.6	19.6
S32W	5	2.83	5.57	8.4	11.2	14.3	16.8	19.2	2.83	5.47	8.4	11.3	14.0	16.7	19.4
S32W	6	2.83	5.57	8.5	11.2	14.2	—	—	2.83	5.57	8.4	11.2	14.1	16.9	—
S32W	7	2.83	5.57	8.4	11.2	14.3	16.9	19.6	2.83	5.57	8.4	11.2	14.0	16.7	19.6
S32W	8	2.83	5.57	8.4	11.3	13.8	16.8	19.6	2.83	5.47	8.3	11.2	14.0	16.9	19.6
S32W	9	2.83	5.57	8.4	11.2	13.9	16.9	19.6	2.83	5.47	8.4	11.2	14.0	16.7	19.5

*Baseline run.

**Multiple excitation on same data run.

^Missing file.

—No data available.

Table 13. Phase 3 average mode frequencies (Hz).

Cable	1	2	3	4	5	6	7
N01	2.93	—	—	—	—	—	—
N02	2.93	4.88	8.98	12.70	—	—	—
N03	5.08	—	—	—	—	—	—
N34E	2.15	4.30	6.45	8.59	10.74	12.89	15.04
N33E	2.34	4.88	7.42	9.57	11.91	14.26	16.80
N32E	2.73	5.57	8.20	11.13	13.57	16.21	18.85
N34W	2.15	4.32	6.49	8.62	10.72	12.92	15.01
N33W	2.39	4.64	7.15	9.67	11.91	—	—
N32W	2.64	5.23	7.89	10.50	13.06	—	—
S01	3.52	7.03	10.45	13.96	17.38	21.09	24.41
S02	3.91	7.62	11.52	15.04	18.55	22.07	25.98
S03	4.49	9.38	13.48	—	—	—	—
S34E	2.34	4.59	6.93	9.18	11.62	13.77	16.21
S33E	2.54	5.18	7.91	10.35	13.18	15.43	18.26
S32E	2.83	5.66	8.40	11.52	14.26	17.19	—
S34W	2.25	4.40	6.64	8.89	11.13	13.28	15.53
S33W	2.44	4.79	7.32	9.86	12.21	14.65	17.19
S32W	2.83	5.57	8.40	11.23	13.96	16.80	19.53

—No data available.

APPENDIX B. MODE FREQUENCY PLOTS

In appendix B plots, data from north and south towers are combined to illustrate how the mode frequencies trended during the three phases of testing. While there is a slight variation between the findings for the north and south towers in each phase, as depicted in figure 84 through figure 88, the purpose of these charts is to illustrate the frequency trends for each phase rather than specific data points. To view the comparison of first- and second-mode frequencies, please refer to figure 52 and figure 53, respectively. A complete table of frequency values can be found in appendix A, table 13.

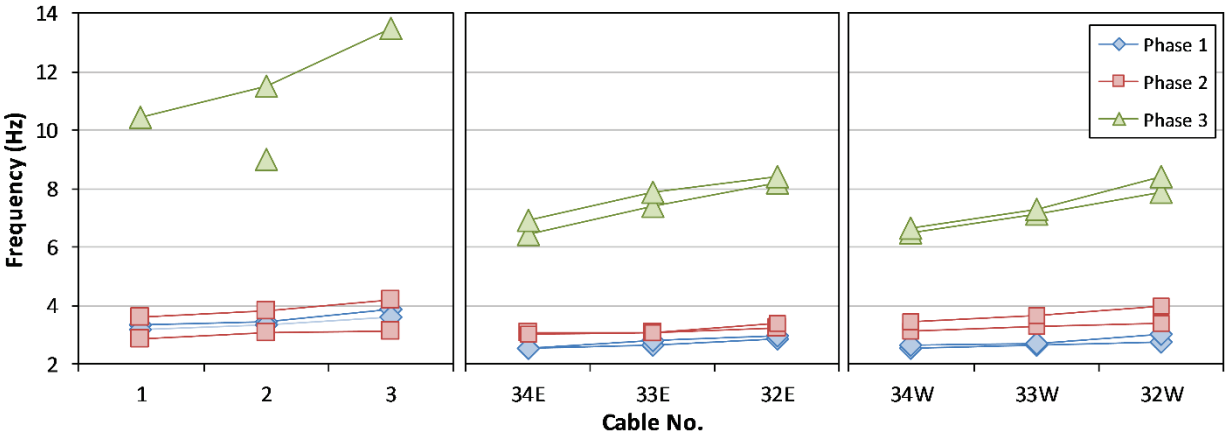

Source: FHWA.

Figure 84. Graph. Comparison of third-mode frequencies for all phases for (left to right) main-span, side-span east, and side-span west cables.

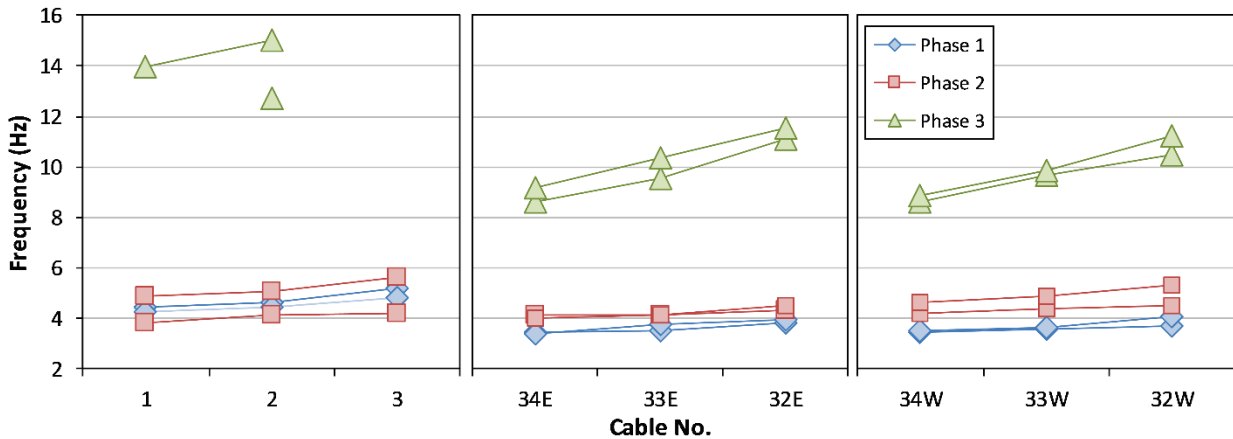

Source: FHWA.

Figure 85. Graph. Comparison of fourth-mode frequencies for all phases for (left to right) main-span, side-span east, and side-span west cables.

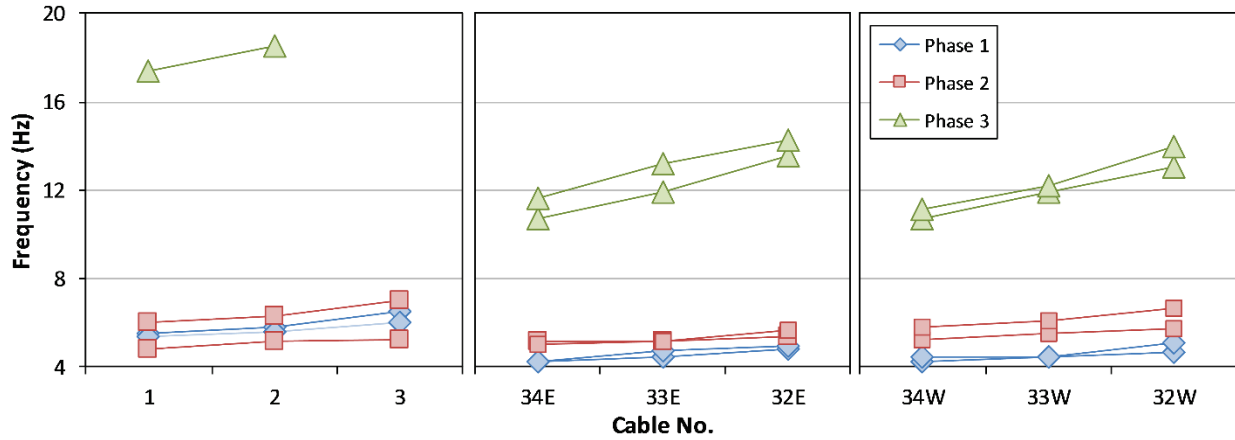

Source: FHWA.

Figure 86. Graph. Comparison of fifth-mode frequencies for all phases for (left to right) main-span, side-span east, and side-span west cables.

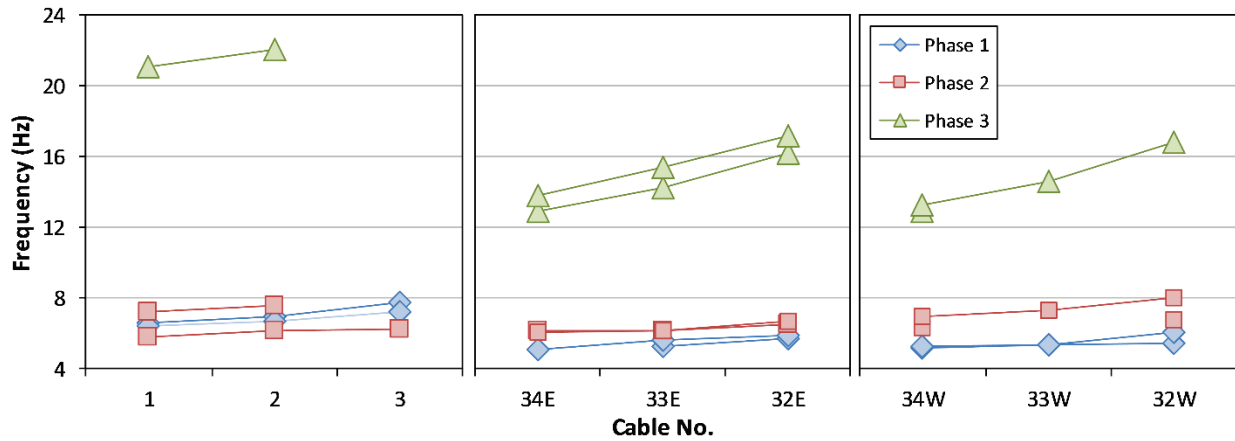

Source: FHWA.

Figure 87. Graph. Comparison of sixth-mode frequencies for all phases for (left to right) main-span, side-span east, and side-span west cables.

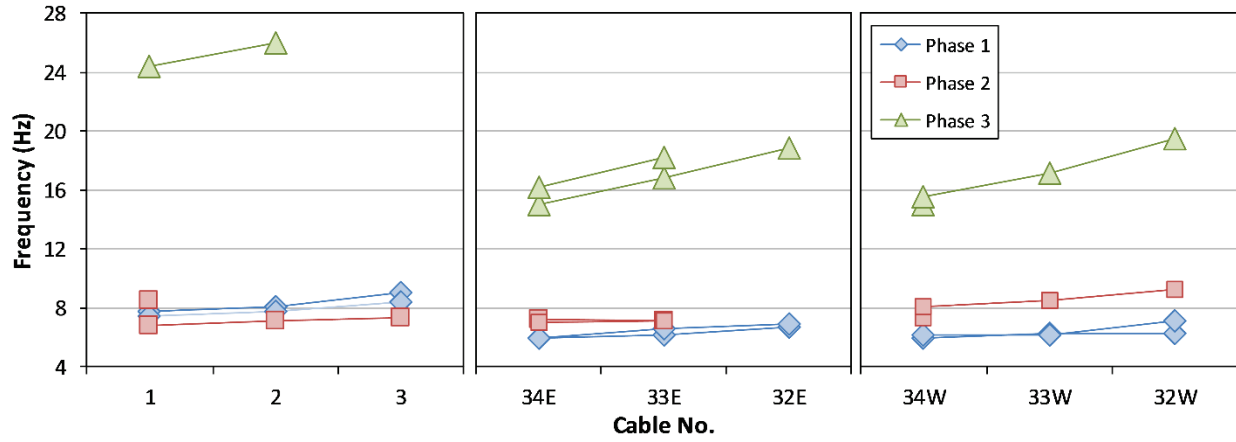

Source: FHWA.

Figure 88. Graph. Comparison of seventh-mode frequencies for all phases for (left to right) main-span, side-span east, and side-span west cables.

APPENDIX C. DAMPING RATIO TABLES

Table 14. Phase 1, box 1, first-mode damping data.

Cable	Run	Bandpass Filter		Time Filter		Positive Peaks		Negative Peaks	
		Low (Hz)	High (Hz)	Start (s)	End (s)	Damping (Percent)	Correlation	Damping (Percent)	Correlation
N01	1*	—	—	—	—	—	—	—	—
N01	2	0.80	1.50	10	125	0.274	0.9992	0.274	0.9993
N01	3	0.80	1.50	20	120	0.240	0.9989	0.240	0.9990
N01	4	0.80	1.50	15	120	0.258	0.9991	0.258	0.9991
N01	5	0.80	1.50	15	120	0.236	0.9993	0.235	0.9993
N01	6	0.80	1.50	10	120	0.257	0.9971	0.257	0.9971
N01	7	0.80	1.50	15	120	0.230	0.9985	0.230	0.9985
N02	1*	—	—	—	—	—	—	—	—
N02	2	0.80	1.40	10	100	0.315	0.9992	0.315	0.9992
N02	3	0.80	1.40	5	100	0.296	0.9992	0.295	0.9993
N02	4	0.80	1.40	10	100	0.287	0.9994	0.287	0.9994
N02	5	0.80	1.40	7	100	0.300	0.9991	0.299	0.9991
N02	6	0.80	1.40	7	100	0.297	0.9981	0.298	0.9981
N03	1*	—	—	—	—	—	—	—	—
N03	2	0.80	1.70	5	150	0.216	0.9982	0.215	0.9982
N03	3	0.80	1.70	5	150	0.218	0.9971	0.218	0.9972
N03	4	0.80	1.70	10	150	0.213	0.9985	0.213	0.9985
N03	5	0.80	1.70	5	150	0.211	0.9971	0.211	0.9972
N34E	1*	—	—	—	—	—	—	—	—
N34E	2	0.60	1.10	15	150	0.141	0.9944	0.142	0.9945
N34E	3	0.60	1.10	15	200	0.128	0.9970	0.128	0.9971
N34E	4	0.60	1.10	5	180	0.152	0.9953	0.152	0.9954
N34E	5	0.60	1.10	10	220	0.133	0.9988	0.133	0.9988
N34E	6	0.60	1.10	10	170	0.157	0.9958	0.156	0.9957
N34E	7	0.60	1.05	5	160	0.134	0.9886	0.134	0.9884

Cable	Run	Bandpass Filter		Time Filter		Positive Peaks		Negative Peaks	
		Low (Hz)	High (Hz)	Start (s)	End (s)	Damping (Percent)	Correlation	Damping (Percent)	Correlation
N33E	1	0.60	1.10	10	200	0.177	0.9996	0.177	0.9996
N33E	2	0.60	1.10	10	210	0.148	0.9993	0.148	0.9992
N33E	3	0.60	1.10	10	300	0.130	0.9990	0.130	0.9990
N33E	4*	—	—	—	—	—	—	—	—
N33E	5	0.60	1.10	10	250	0.171	0.9995	0.171	0.9995
N33E	6	0.60	1.10	5	250	0.169	0.9988	0.169	0.9988
N33E	7	0.60	1.10	5	250	0.156	0.9993	0.156	0.9992
N32E	1	0.60	1.10	5	250	0.200	0.9986	0.200	0.9987
N32E	2	0.70	1.20	5	200	0.184	0.9981	0.184	0.9982
N32E	3	0.70	1.20	10	300	0.189	0.9991	0.189	0.9991
N32E	4	0.70	1.20	5	300	0.191	0.9994	0.191	0.9994
N32E	5	0.70	1.20	5	300	0.195	0.9973	0.195	0.9972
N32E	6	0.70	1.20	13	200	0.206	0.9979	0.206	0.9979
N32E	7*	—	—	—	—	—	—	—	—
N34W	1*	—	—	—	—	—	—	—	—
N34W	2	0.60	1.10	5	300	0.154	0.9994	0.153	0.9995
N34W	3*	—	—	—	—	—	—	—	—
N34W	4	0.60	1.10	5	300	0.172	0.9990	0.172	0.9990
N34W	5	0.60	1.10	10	200	0.177	0.9983	0.177	0.9983
N34W	6	0.60	1.10	10	200	0.157	0.9998	0.157	0.9998
N34W	7	0.60	1.10	5	200	0.220	0.9996	0.220	0.9996
N34W	8	0.60	1.10	5	200	0.166	0.9993	0.167	0.9991
N33W	1*	—	—	—	—	—	—	—	—
N33W	2	0.60	1.10	10	300	0.190	0.9990	0.190	0.9990
N33W	3	0.60	1.10	10	200	0.215	0.9993	0.215	0.9993
N33W	4	0.60	1.10	10	300	0.190	0.9997	0.190	0.9997
N33W	5	0.60	1.10	5	250	0.154	0.9995	0.154	0.9995
N33W	6	0.60	1.10	10	300	0.186	0.9994	0.186	0.9994
N33W	7	0.60	1.10	5	300	0.196	0.9994	0.196	0.9995

Cable	Run	Bandpass Filter		Time Filter		Positive Peaks		Negative Peaks	
		Low (Hz)	High (Hz)	Start (s)	End (s)	Damping (Percent)	Correlation	Damping (Percent)	Correlation
N32W	1	0.70	1.20	5	150	0.268	0.9995	0.268	0.9994
N32W	2	0.70	1.20	10	150	0.349	0.9991	0.349	0.9990
N32W	3	0.70	1.20	5	140	0.333	0.9985	0.333	0.9986
N32W	4	0.70	1.20	10	150	0.330	0.9992	0.330	0.9992
N32W	5	0.70	1.20	5	150	0.309	0.9986	0.309	0.9986
N32W	6	0.70	1.20	5	120	0.223	0.9987	0.224	0.9986
S01	1	0.70	1.40	5	200	0.166	0.9990	0.166	0.9990
S01	2	0.70	1.40	10	250	0.141	0.9990	0.141	0.9990
S01	3	0.70	1.40	5	250	0.163	0.9981	0.163	0.9981
S01	4	0.70	1.40	5	250	0.140	0.9986	0.140	0.9986
S01	5	0.70	1.40	5	200	0.145	0.9977	0.145	0.9977
S02	1*	—	—	—	—	—	—	—	—
S02	2	0.70	1.40	5	200	0.197	0.9992	0.197	0.9992
S02	3	0.70	1.40	10	220	0.201	0.9973	0.200	0.9973
S02	4	0.70	1.40	5	200	0.188	0.9983	0.188	0.9983
S02	5	0.70	1.40	5	300	0.178	0.9985	0.178	0.9985
S02	6	0.70	1.40	5	200	0.190	0.9985	0.190	0.9985
S02	7	0.70	1.40	5	200	0.188	0.9983	0.188	0.9983
S03	1*	—	—	—	—	—	—	—	—
S03	2	0.70	1.40	5	200	0.215	0.9994	0.215	0.9994
S03	3	0.70	1.40	5	170	0.218	0.9980	0.218	0.9985
S03	4	0.70	1.40	5	160	0.222	0.9997	0.222	0.9997
S03	5	0.80	1.40	5	160	0.213	0.9993	0.213	0.9992
S03	6	0.80	1.40	5	200	0.209	0.9997	0.209	0.9997
S03	7	0.80	1.40	5	170	0.218	0.9996	0.218	0.9996
S34E	1*	—	—	—	—	—	—	—	—
S34E	2	0.70	1.10	—	—	—	—	—	—
S34E	3	0.70	1.10	10	300	0.128	0.9991	0.128	0.9991
S34E	4	0.70	1.10	10	300	0.145	0.9995	0.145	0.9995

Cable	Run	Bandpass Filter		Time Filter		Positive Peaks		Negative Peaks	
		Low (Hz)	High (Hz)	Start (s)	End (s)	Damping (Percent)	Correlation	Damping (Percent)	Correlation
S34E	5	0.70	1.10	7	300	0.143	0.9986	0.143	0.9986
S34E	6	0.70	1.10	10	300	0.125	0.9990	0.125	0.9990
S34E	7	0.70	1.10	10	300	0.125	0.9989	0.125	0.9989
S34E	8*	—	—	—	—	—	—	—	—
S33E	1	0.70	1.20	10	300	0.154	0.9994	0.154	0.9993
S33E	2	0.70	1.20	10	300	0.117	0.9981	0.117	0.9982
S33E	3	0.70	1.20	10	300	0.113	0.9996	0.113	0.9995
S33E	4	0.70	1.20	10	300	0.129	0.9994	0.129	0.9994
S33E	5*	—	—	—	—	—	—	—	—
S33E	6	0.70	1.20	120	350	0.168	0.9994	0.168	0.9994
S33E	7	0.70	1.20	10	200	0.151	0.9993	0.151	0.9993
S32E	1	0.80	1.20	5	300	0.163	0.9991	0.163	0.9991
S32E	2*	—	—	—	—	—	—	—	—
S32E	3	0.80	1.20	10	150	0.197	0.9995	0.198	0.9995
S32E	4	0.80	1.20	10	160	0.209	0.9960	0.209	0.9960
S32E	5	0.80	1.20	5	200	0.219	0.9992	0.219	0.9992
S32E	6	0.80	1.20	5	200	0.215	0.9973	0.215	0.9973
S32E	7	0.80	1.20	5	200	0.169	0.9944	0.169	0.9945
S34W	1*	—	—	—	—	—	—	—	—
S34W	2	0.70	1.10	5	150	0.195	0.9960	0.194	0.9961
S34W	3	0.70	1.10	5	170	0.247	0.9947	0.247	0.9945
S34W	4	0.70	1.10	10	250	0.169	0.9986	0.170	0.9986
S34W	5	0.70	1.10	10	200	0.176	0.9982	0.176	0.9984
S34W	6	0.70	1.10	—	—	—	—	—	—
S34W	7	0.70	1.10	10	200	0.187	0.9988	0.187	0.9988
S34W	8	0.70	1.10	5	210	0.182	0.9970	0.182	0.9970
S33W	1*	—	—	—	—	—	—	—	—
S33W	2	0.70	1.20	5	120	0.266	0.9979	0.267	0.9978
S33W	3	0.70	1.20	5	150	0.298	0.9981	0.298	0.9981

Cable	Run	Bandpass Filter		Time Filter		Positive Peaks		Negative Peaks	
		Low (Hz)	High (Hz)	Start (s)	End (s)	Damping (Percent)	Correlation	Damping (Percent)	Correlation
S33W	4	0.70	1.20	5	150	0.321	0.9978	0.321	0.9977
S33W	5	0.70	1.20	5	150	0.234	0.9978	0.234	0.9978
S33W	6	0.70	1.20	5	150	0.253	0.9973	0.253	0.9973
S33W	7	0.70	1.20	5	150	0.175	0.9991	0.175	0.9991
S32W	1*	—	—	—	—	—	—	—	—
S32W	2	0.70	1.30	5	200	0.135	0.9990	0.135	0.9990
S32W	3	0.70	1.30	5	250	0.123	0.9964	0.123	0.9965
S32W	4	0.70	1.30	5	300	0.101	0.9981	0.101	0.9981
S32W	5	0.70	1.30	15	300	0.125	0.9993	0.125	0.9993
S32W	6	0.70	1.30	5	300	0.104	0.9984	0.104	0.9984
S32W	7	0.70	1.30	5	300	0.132	0.9994	0.132	0.9994

*Baseline runs.

—No data available.

Table 15. Phase 1, box 2, first-mode damping data.

Cable	Run	Bandpass Filter		Time Filter		Positive Peaks		Negative Peaks	
		Low (Hz)	High (Hz)	Start (s)	End (s)	Damping (Percent)	Correlation	Damping (Percent)	Correlation
N01	1*	—	—	—	—	—	—	—	—
N01	2**	—	—	—	—	—	—	—	—
N01	3**	—	—	—	—	—	—	—	—
N01	4**	—	—	—	—	—	—	—	—
N01	5**	—	—	—	—	—	—	—	—
N01	6**	—	—	—	—	—	—	—	—
N01	7	0.80	1.50	15	130	0.239	0.9976	0.239	0.9976
N02	1*	—	—	—	—	—	—	—	—
N02	2**	—	—	—	—	—	—	—	—
N02	3**	—	—	—	—	—	—	—	—
N02	4**	—	—	—	—	—	—	—	—
N02	5**	—	—	—	—	—	—	—	—
N02	6**	—	—	—	—	—	—	—	—
N03	1*	—	—	—	—	—	—	—	—
N03	2**	—	—	—	—	—	—	—	—
N03	3**	—	—	—	—	—	—	—	—
N03	4**	—	—	—	—	—	—	—	—
N03	5**	—	—	—	—	—	—	—	—
N34E	1*	—	—	—	—	—	—	—	—
N34E	2**	—	—	—	—	—	—	—	—
N34E	3**	—	—	—	—	—	—	—	—
N34E	4**	—	—	—	—	—	—	—	—
N34E	5**	—	—	—	—	—	—	—	—
N34E	6**	—	—	—	—	—	—	—	—
N34E	7**	—	—	—	—	—	—	—	—
N33E	1**	—	—	—	—	—	—	—	—
N33E	2**	—	—	—	—	—	—	—	—
N33E	3**	—	—	—	—	—	—	—	—

Cable	Run	Bandpass Filter		Time Filter		Positive Peaks		Negative Peaks	
		Low (Hz)	High (Hz)	Start (s)	End (s)	Damping (Percent)	Correlation	Damping (Percent)	Correlation
N33E	4*	—	—	—	—	—	—	—	—
N33E	5**	—	—	—	—	—	—	—	—
N33E	6**	—	—	—	—	—	—	—	—
N33E	7**	—	—	—	—	—	—	—	—
N32E	1**	—	—	—	—	—	—	—	—
N32E	2**	—	—	—	—	—	—	—	—
N32E	3**	—	—	—	—	—	—	—	—
N32E	4**	—	—	—	—	—	—	—	—
N32E	5**	—	—	—	—	—	—	—	—
N32E	6**	—	—	—	—	—	—	—	—
N32E	7*	—	—	—	—	—	—	—	—
N34W	1*	—	—	—	—	—	—	—	—
N34W	2	0.60	1.10	5	300	0.154	0.9993	0.154	0.9993
N34W	3*	—	—	—	—	—	—	—	—
N34W	4	0.60	1.10	5	200	0.169	0.9967	0.169	0.9966
N34W	5	0.60	1.10	10	200	0.177	0.9982	0.177	0.9982
N34W	6	0.60	1.10	10	200	0.157	0.9996	0.157	0.9996
N34W	7	0.60	1.10	5	200	0.220	0.9995	0.220	0.9995
N34W	8	0.60	1.10	5	200	0.167	0.9989	0.167	0.9988
N33W	1*	—	—	—	—	—	—	—	—
N33W	2	0.60	1.20	5	300	0.192	0.9988	0.192	0.9988
N33W	3	0.60	1.20	5	300	0.201	0.9983	0.201	0.9983
N33W	4	0.60	1.20	5	300	0.191	0.9996	0.191	0.9996
N33W	5	0.60	1.20	5	200	0.154	0.9996	0.154	0.9996
N33W	6	0.60	1.20	5	300	0.189	0.9993	0.189	0.9994
N33W	7	0.60	1.20	5	300	0.197	0.9994	0.197	0.9994
N32W	1	0.70	1.20	5	200	0.256	0.9994	0.256	0.9994
N32W	2	0.70	1.20	10	150	0.343	0.9980	0.343	0.9980
N32W	3	0.70	1.20	5	150	0.327	0.9971	0.327	0.9971

Cable	Run	Bandpass Filter		Time Filter		Positive Peaks		Negative Peaks	
		Low (Hz)	High (Hz)	Start (s)	End (s)	Damping (Percent)	Correlation	Damping (Percent)	Correlation
N32W	4	0.70	1.20	10	200	0.336	0.9982	0.337	0.9981
N32W	5	0.70	1.20	5	160	0.304	0.9967	0.304	0.9967
N32W	6	0.70	1.20	5	200	0.221	0.9965	0.221	0.9966
S01	1	0.80	1.40	5	220	0.164	0.9990	0.164	0.9990
S01	2	0.80	1.40	5	300	0.141	0.9991	0.141	0.9991
S01	3	0.80	1.40	5	230	0.163	0.9983	0.163	0.9983
S01	4	0.80	1.40	5	250	0.141	0.9991	0.141	0.9990
S01	5	0.80	1.40	5	220	0.143	0.9979	0.143	0.9979
S02	1*	—	—	—	—	—	—	—	—
S02	2	0.80	1.40	10	200	0.196	0.9995	0.196	0.9996
S02	3	0.80	1.40	10	250	0.196	0.9977	0.195	0.9977
S02	4	0.80	1.40	5	220	0.188	0.9990	0.188	0.9990
S02	5	0.80	1.40	5	250	0.183	0.9933	0.184	0.9908
S02	6	0.80	1.40	5	250	0.185	0.9994	0.185	0.9994
S02	7	0.80	1.40	5	200	0.188	0.9991	0.188	0.9991
S03	1*	—	—	—	—	—	—	—	—
S03	2	0.90	1.50	5	200	0.211	0.9995	0.211	0.9995
S03	3	0.90	1.50	5	200	0.216	0.9991	0.216	0.9992
S03	4	0.90	1.50	5	160	0.220	0.9996	0.220	0.9996
S03	5	0.90	1.50	5	150	0.207	0.9994	0.207	0.9994
S03	6	0.90	1.50	5	200	0.202	0.9996	0.202	0.9996
S03	7	0.90	1.50	5	200	0.216	0.9995	0.216	0.9995
S34E	1	—	—	—	—	—	—	—	—
S34E	2	0.60	1.10	—	—	—	—	—	—
S34E	3	0.60	1.10	5	300	0.129	0.9988	0.128	0.9989
S34E	4	0.60	1.10	5	300	0.145	0.9991	0.144	0.9992
S34E	5	0.60	1.10	5	300	0.143	0.9986	0.143	0.9985
S34E	6	0.60	1.10	5	350	0.127	0.9991	0.126	0.9992
S34E	7	0.60	1.10	5	300	0.126	0.9988	0.126	0.9986

Cable	Run	Bandpass Filter		Time Filter		Positive Peaks		Negative Peaks	
		Low (Hz)	High (Hz)	Start (s)	End (s)	Damping (Percent)	Correlation	Damping (Percent)	Correlation
S34E	8*	—	—	—	—	—	—	—	—
S33E	1	0.70	1.20	5	300	0.154	0.9995	0.154	0.9994
S33E	2	0.70	1.20	5	300	0.118	0.9978	0.118	0.9976
S33E	3	0.70	1.20	5	300	0.114	0.9992	0.114	0.9994
S33E	4	0.70	1.20	5	300	0.130	0.9991	0.130	0.9992
S33E	5*	—	—	—	—	—	—	—	—
S33E	6	0.60	1.20	120	320	0.169	0.9994	0.169	0.9994
S33E	7	0.60	1.20	5	200	0.150	0.9991	0.150	0.9990
S32E	1	0.70	1.20	5	270	0.167	0.9994	0.167	0.9994
S32E	2*	—	—	—	—	—	—	—	—
S32E	3	0.70	1.20	5	200	0.195	0.9994	0.195	0.9993
S32E	4	0.70	1.20	5	200	0.205	0.9979	0.205	0.9981
S32E	5	0.70	1.20	5	200	0.221	0.9993	0.221	0.9993
S32E	6	0.70	1.20	5	200	0.219	0.9987	0.219	0.9987
S32E	7	0.70	1.20	5	250	0.168	0.9976	0.168	0.9975
S34W	1*	—	—	—	—	—	—	—	—
S34W	2	0.60	1.10	5	190	0.192	0.9979	0.192	0.9977
S34W	3	0.60	1.10	5	150	0.240	0.9935	0.240	0.9936
S34W	4	0.60	1.10	5	300	0.172	0.9987	0.172	0.9988
S34W	5	0.60	1.10	5	220	0.184	0.9981	0.184	0.9980
S34W	6	0.60	1.10	5	200	0.205	0.9981	0.205	0.9981
S34W	7	0.60	1.10	5	220	0.189	0.9988	0.189	0.9987
S34W	8	0.60	1.10	5	250	0.186	0.9985	0.186	0.9985
S33W	1*	—	—	—	—	—	—	—	—
S33W	2	0.70	1.10	5	150	0.285	0.9959	0.286	0.9959
S33W	3	0.70	1.10	5	200	0.306	0.9987	0.306	0.9987
S33W	4	0.70	1.10	5	150	0.320	0.9974	0.320	0.9974
S33W	5	0.70	1.10	5	180	0.246	0.9968	0.246	0.9969
S33W	6	0.70	1.10	5	150	0.255	0.9974	0.256	0.9973

Cable	Run	Bandpass Filter		Time Filter		Positive Peaks		Negative Peaks	
		Low (Hz)	High (Hz)	Start (s)	End (s)	Damping (Percent)	Correlation	Damping (Percent)	Correlation
S33W	7	0.70	1.10	5	300	0.190	0.9991	0.190	0.9991
S32W	1*	—	—	—	—	—	—	—	—
S32W	2	0.80	1.30	10	300	0.124	0.9979	0.124	0.9980
S32W	3	0.80	1.30	10	300	0.123	0.9978	0.123	0.9978
S32W	4	0.80	1.30	10	300	0.100	0.9978	0.100	0.9979
S32W	5	0.80	1.30	15	300	0.126	0.9993	0.126	0.9993
S32W	6	0.80	1.30	10	300	0.104	0.9986	0.104	0.9987
S32W	7	0.80	1.30	10	280	0.132	0.9997	0.132	0.9997

*Baseline runs.

**Box 2 data corrupted.

—No data available.

Table 16. Phase 1, box 1, second-mode damping data.

Cable	Run	Bandpass Filter		Time Filter		Positive Peaks		Negative Peaks	
		Low (Hz)	High (Hz)	Start (s)	End (s)	Damping (Percent)	Correlation	Damping (Percent)	Correlation
N01	1*	—	—	—	—	—	—	—	—
N01	2	1.90	2.50	—	—	—	—	—	—
N01	3	1.90	2.50	20	35	0.455	0.9956	0.456	0.9961
N01	4	1.90	2.50	13	31	0.581	0.9997	0.581	0.9997
N01	5	1.90	2.50	14	29	0.783	0.9993	0.789	0.9993
N01	6	1.90	2.50	8	28	0.473	0.9946	0.475	0.9948
N01	7	1.90	2.50	16	37	0.496	0.9987	0.498	0.9988
N02	1*	—	—	—	—	—	—	—	—
N02	2	1.90	2.60	—	—	—	—	—	—
N02	3	1.90	2.60	—	—	—	—	—	—
N02	4	1.90	2.60	—	—	—	—	—	—
N02	5	1.90	2.60	—	—	—	—	—	—
N02	6	1.90	2.60	—	—	—	—	—	—
N03	1*	—	—	—	—	—	—	—	—
N03	2	2.20	2.90	15	80	0.148	0.9960	0.148	0.9959
N03	3	2.20	2.90	5	60	0.292	0.9954	0.292	0.9954
N03	4	2.20	2.90	10	50	0.336	0.9931	0.338	0.9935
N03	5	2.20	2.90	5	50	0.321	0.9869	0.323	0.9873
N34E	1*	—	—	—	—	—	—	—	—
N34E	2	1.50	1.90	—	—	—	—	—	—
N34E	3	1.50	1.90	—	—	—	—	—	—
N34E	4	1.50	1.90	—	—	—	—	—	—
N34E	5	1.50	1.90	—	—	—	—	—	—
N34E	6	1.50	1.90	—	—	—	—	—	—
N34E	7	1.50	1.90	—	—	—	—	—	—
N33E	1	1.60	2.00	—	—	—	—	—	—
N33E	2	1.60	2.00	—	—	—	—	—	—
N33E	3	1.60	2.00	—	—	—	—	—	—

Cable	Run	Bandpass Filter		Time Filter		Positive Peaks		Negative Peaks	
		Low (Hz)	High (Hz)	Start (s)	End (s)	Damping (Percent)	Correlation	Damping (Percent)	Correlation
N33E	4*	—	—	—	—	—	—	—	—
N33E	5	1.60	2.00	—	—	—	—	—	—
N33E	6	1.60	2.00	—	—	—	—	—	—
N33E	7	1.60	2.00	—	—	—	—	—	—
N32E	1	1.60	2.20	10	40	0.465	0.9916	0.469	0.9914
N32E	2	1.60	2.20	5	40	0.450	0.9979	0.448	0.9979
N32E	3	1.60	2.20	7	60	0.404	0.9984	0.405	0.9984
N32E	4	1.60	2.20	5	55	0.479	0.9960	0.478	0.9960
N32E	5	1.60	2.20	5	45	0.625	0.9950	0.625	0.9951
N32E	6	1.60	2.20	10	60	0.423	0.9947	0.421	0.9945
N32E	7*	—	—	—	—	—	—	—	—
N34W	1*	—	—	—	—	—	—	—	—
N34W	2	1.50	1.90	5	50	0.413	0.9602	0.407	0.9622
N34W	3*	—	—	—	—	—	—	—	—
N34W	4	1.50	1.90	10	85	0.197	0.9978	0.197	0.9978
N34W	5	1.50	1.90	10	70	0.285	0.9884	0.287	0.9881
N34W	6	1.50	1.90	5	70	0.535	0.9902	0.534	0.9896
N34W	7	1.50	1.90	5	80	0.218	0.9970	0.217	0.9970
N34W	8	1.50	1.90	5	80	0.208	0.9949	0.209	0.9954
N33W	1*	—	—	—	—	—	—	—	—
N33W	2	1.60	2.00	15	150	0.162	0.9958	0.162	0.9958
N33W	3	1.60	2.00	10	150	0.160	0.9977	0.160	0.9977
N33W	4	1.60	2.00	5	150	0.202	0.9967	0.202	0.9967
N33W	5	1.60	2.00	5	170	0.177	0.9971	0.177	0.9971
N33W	6	1.60	2.00	5	150	0.176	0.9978	0.176	0.9977
N33W	7	1.60	2.00	5	140	0.176	0.9969	0.177	0.9969
N32W	1	1.60	2.10	—	—	—	—	—	—
N32W	2	1.60	2.10	10	60	0.453	0.9981	0.452	0.9980
N32W	3	1.60	2.10	5	50	0.321	0.9900	0.321	0.9901

Cable	Run	Bandpass Filter		Time Filter		Positive Peaks		Negative Peaks	
		Low (Hz)	High (Hz)	Start (s)	End (s)	Damping (Percent)	Correlation	Damping (Percent)	Correlation
N32W	4	1.60	2.10	5	50	0.322	0.9884	0.322	0.9884
N32W	5	1.60	2.10	5	60	0.331	0.9904	0.330	0.9902
N32W	6	1.60	2.10	10	90	0.251	0.9935	0.252	0.9935
S01	1	1.80	2.40	20	70	0.373	0.9958	0.372	0.9956
S01	2	1.80	2.40	5	60	0.299	0.9909	0.299	0.9911
S01	3	1.80	2.40	15	60	0.285	0.9822	0.287	0.9827
S01	4	1.80	2.40	20	70	0.342	0.9905	0.343	0.9909
S01	5	1.80	2.40	15	60	0.312	0.9899	0.313	0.9903
S02	1*	—	—	—	—	—	—	—	—
S02	2	1.90	2.50	25	60	0.290	0.9886	0.292	0.9890
S02	3	1.90	2.50	30	70	0.276	0.9917	0.275	0.9916
S02	4	1.90	2.50	15	60	0.357	0.9859	0.356	0.9856
S02	5	1.90	2.50	20	60	0.351	0.9887	0.350	0.9883
S02	6	1.90	2.50	20	70	0.325	0.9853	0.324	0.9852
S02	7	1.90	2.50	20	60	0.428	0.9904	0.427	0.9901
S03	1*	—	—	—	—	—	—	—	—
S03	2	2.10	2.70	10	80	0.155	0.9933	0.155	0.9933
S03	3	2.10	2.70	5	100	0.166	0.9892	0.166	0.9891
S03	4	2.10	2.70	5	80	0.159	0.9887	0.159	0.9886
S03	5	2.10	2.70	5	80	0.174	0.9701	0.174	0.9700
S03	6	2.10	2.70	5	80	0.178	0.9789	0.179	0.9782
S03	7	2.10	2.70	5	80	0.179	0.9786	0.178	0.9789
S34E	1*	—	—	—	—	—	—	—	—
S34E	2	1.40	2.00	5	100	0.253	0.9975	0.253	0.9975
S34E	3	1.40	2.00	—	—	—	—	—	—
S34E	4	1.40	2.00	10	160	0.123	0.9973	0.123	0.9973
S34E	5	1.40	2.00	—	—	—	—	—	—
S34E	6	1.40	2.00	—	—	—	—	—	—
S34E	7	1.40	2.00	—	—	—	—	—	—

Cable	Run	Bandpass Filter		Time Filter		Positive Peaks		Negative Peaks	
		Low (Hz)	High (Hz)	Start (s)	End (s)	Damping (Percent)	Correlation	Damping (Percent)	Correlation
S34E	8*	—	—	—	—	—	—	—	—
S33E	1	1.60	2.20	—	—	—	—	—	—
S33E	2	1.60	2.20	—	—	—	—	—	—
S33E	3	1.60	2.20	—	—	—	—	—	—
S33E	4	1.60	2.20	—	—	—	—	—	—
S33E	5*	—	—	—	—	—	—	—	—
S33E	6	1.60	2.20	—	—	—	—	—	—
S33E	7	1.60	2.20	—	—	—	—	—	—
S32E	1	1.70	2.20	5	40	0.372	0.9806	0.370	0.9811
S32E	2*	—	—	—	—	—	—	—	—
S32E	3	1.70	2.20	—	—	—	—	—	—
S32E	4	1.70	2.20	—	—	—	—	—	—
S32E	5	1.70	2.20	—	—	—	—	—	—
S32E	6	1.70	2.20	—	—	—	—	—	—
S32E	7	1.70	2.20	5	70	0.287	0.9795	0.288	0.9796
S34W	1*	—	—	—	—	—	—	—	—
S34W	2	1.50	2.00	25	170	0.146	0.9961	0.146	0.9961
S34W	3	1.50	2.00	35	150	0.182	0.9945	0.182	0.9944
S34W	4	1.50	2.00	30	100	0.092	0.9925	0.092	0.9926
S34W	5	1.50	2.00	35	160	0.145	0.9961	0.145	0.9961
S34W	6	1.50	2.00	—	—	—	—	—	—
S34W	7	1.50	2.00	30	140	0.204	0.9970	0.204	0.9970
S34W	8	1.50	2.00	35	140	0.177	0.9971	0.177	0.9971
S33W	1*	—	—	—	—	—	—	—	—
S33W	2	1.50	2.10	—	—	—	—	—	—
S33W	3	1.50	2.10	5	110	0.157	0.9463	0.157	0.9463
S33W	4	1.50	2.10	5	100	0.216	0.9909	0.216	0.9910
S33W	5	1.50	2.10	5	140	0.173	0.9929	0.173	0.9929
S33W	6	1.50	2.10	5	85	0.158	0.9765	0.157	0.9770

Cable	Run	Bandpass Filter		Time Filter		Positive Peaks		Negative Peaks	
		Low (Hz)	High (Hz)	Start (s)	End (s)	Damping (Percent)	Correlation	Damping (Percent)	Correlation
S33W	7	1.50	2.10	5	100	0.164	0.9944	0.164	0.9943
S32W	1*	—	—	—	—	—	—	—	—
S32W	2	1.70	2.20	70	200	0.123	0.9941	0.123	0.9941
S32W	3	1.70	2.20	60	250	0.101	0.9925	0.101	0.9926
S32W	4	1.70	2.20	40	160	0.100	0.9954	0.100	0.9955
S32W	5	1.70	2.20	50	250	0.091	0.9924	0.091	0.9924
S32W	6	1.70	2.20	90	250	0.066	0.9967	0.066	0.9966
S32W	7	1.70	2.20	50	200	0.107	0.9688	0.108	0.9687

*Baseline run.

—No data available.

Table 17. Phase 1, box 2, second-mode damping data.

Cable	Run	Bandpass Filter		Time Filter		Positive Peaks		Negative Peaks	
		Low (Hz)	High (Hz)	Start (s)	End (s)	Damping (Percent)	Correlation	Damping (Percent)	Correlation
N01	1*	—	—	—	—	—	—	—	—
N01	2**	—	—	—	—	—	—	—	—
N01	3**	—	—	—	—	—	—	—	—
N01	4**	—	—	—	—	—	—	—	—
N01	5**	—	—	—	—	—	—	—	—
N01	6**	—	—	—	—	—	—	—	—
N01	7	1.90	2.50	—	—	—	—	—	—
N02	1*	—	—	—	—	—	—	—	—
N02	2**	—	—	—	—	—	—	—	—
N02	3**	—	—	—	—	—	—	—	—
N02	4**	—	—	—	—	—	—	—	—
N02	5**	—	—	—	—	—	—	—	—
N02	6**	—	—	—	—	—	—	—	—
N03	1*	—	—	—	—	—	—	—	—
N03	2**	—	—	—	—	—	—	—	—
N03	3**	—	—	—	—	—	—	—	—
N03	4**	—	—	—	—	—	—	—	—
N03	5**	—	—	—	—	—	—	—	—
N34E	1*	—	—	—	—	—	—	—	—
N34E	2**	—	—	—	—	—	—	—	—
N34E	3**	—	—	—	—	—	—	—	—
N34E	4**	—	—	—	—	—	—	—	—
N34E	5**	—	—	—	—	—	—	—	—
N34E	6**	—	—	—	—	—	—	—	—
N34E	7**	—	—	—	—	—	—	—	—
N33E	1**	—	—	—	—	—	—	—	—
N33E	2**	—	—	—	—	—	—	—	—
N33E	3**	—	—	—	—	—	—	—	—

Cable	Run	Bandpass Filter		Time Filter		Positive Peaks		Negative Peaks	
		Low (Hz)	High (Hz)	Start (s)	End (s)	Damping (Percent)	Correlation	Damping (Percent)	Correlation
N33E	4*	—	—	—	—	—	—	—	—
N33E	5**	—	—	—	—	—	—	—	—
N33E	6**	—	—	—	—	—	—	—	—
N33E	7**	—	—	—	—	—	—	—	—
N32E	1**	—	—	—	—	—	—	—	—
N32E	2**	—	—	—	—	—	—	—	—
N32E	3**	—	—	—	—	—	—	—	—
N32E	4**	—	—	—	—	—	—	—	—
N32E	5**	—	—	—	—	—	—	—	—
N32E	6**	—	—	—	—	—	—	—	—
N32E	7*	—	—	—	—	—	—	—	—
N34W	1*	—	—	—	—	—	—	—	—
N34W	2	1.50	1.90	—	—	—	—	—	—
N34W	3*	—	—	—	—	—	—	—	—
N34W	4	1.50	1.90	5	80	0.192	0.9968	0.192	0.9969
N34W	5	1.50	1.90	15	70	0.244	0.9931	0.244	0.9930
N34W	6	1.50	1.90	—	—	—	—	—	—
N34W	7	1.50	1.90	5	80	0.203	0.9968	0.203	0.9968
N34W	8	1.50	1.90	5	80	0.199	0.9962	0.199	0.9964
N33W	1*	—	—	—	—	—	—	—	—
N33W	2	1.50	2.10	5	150	0.159	0.9964	0.159	0.9964
N33W	3	1.50	2.10	10	120	0.152	0.9980	0.152	0.9980
N33W	4	1.50	2.10	5	140	0.202	0.9978	0.202	0.9977
N33W	5	1.50	2.10	5	160	0.176	0.9962	0.176	0.9963
N33W	6	1.50	2.10	5	150	0.174	0.9968	0.174	0.9968
N33W	7	1.50	2.10	5	120	0.165	0.9984	0.165	0.9984
N32W	1	1.60	2.20	—	—	—	—	—	—
N32W	2	1.60	2.20	8	55	0.446	0.9987	0.447	0.9989
N32W	3	1.60	2.20	5	70	0.407	0.9863	0.407	0.9862

Cable	Run	Bandpass Filter		Time Filter		Positive Peaks		Negative Peaks	
		Low (Hz)	High (Hz)	Start (s)	End (s)	Damping (Percent)	Correlation	Damping (Percent)	Correlation
N32W	4	1.60	2.20	10	60	0.390	0.9882	0.390	0.9881
N32W	5	1.60	2.20	5	70	0.366	0.9895	0.366	0.9893
N32W	6	1.60	2.20	5	80	0.259	0.9936	0.258	0.9937
S01	1	1.80	2.40	20	70	0.372	0.9958	0.372	0.9959
S01	2	1.80	2.40	10	60	0.324	0.9881	0.323	0.9877
S01	3	1.80	2.40	15	60	0.319	0.9873	0.321	0.9874
S01	4	1.80	2.40	20	65	0.347	0.9950	0.348	0.9952
S01	5	1.80	2.40	15	60	0.339	0.9923	0.340	0.9926
S02	1*	—	—	—	—	—	—	—	—
S02	2	1.90	2.50	25	60	0.288	0.9932	0.289	0.9933
S02	3	1.90	2.50	30	70	0.269	0.9948	0.268	0.9945
S02	4	1.90	2.50	20	60	0.402	0.9915	0.404	0.9917
S02	5	1.90	2.50	20	60	0.352	0.9910	0.350	0.9906
S02	6	1.90	2.50	25	70	0.342	0.9921	0.343	0.9924
S02	7	1.90	2.50	25	60	0.471	0.9929	0.469	0.9927
S03	1*	—	—	—	—	—	—	—	—
S03	2	2.10	2.70	5	100	0.158	0.9950	0.159	0.9949
S03	3	2.10	2.70	5	100	0.149	0.9905	0.149	0.9904
S03	4	2.10	2.70	5	70	0.145	0.9859	0.145	0.9858
S03	5	2.10	2.70	5	100	0.156	0.9764	0.157	0.9764
S03	6	2.10	2.70	5	80	0.171	0.9765	0.172	0.9759
S03	7	2.10	2.70	5	90	0.173	0.9815	0.172	0.9818
S34E	1	—	—	—	—	—	—	—	—
S34E	2	1.40	2.00	5	100	0.258	0.9976	0.258	0.9977
S34E	3	1.40	2.00	—	—	—	—	—	—
S34E	4	1.40	2.00	10	170	0.121	0.9969	0.121	0.9969
S34E	5	1.40	2.00	—	—	—	—	—	—
S34E	6	1.40	2.00	—	—	—	—	—	—
S34E	7	1.40	2.00	—	—	—	—	—	—

Cable	Run	Bandpass Filter		Time Filter		Positive Peaks		Negative Peaks	
		Low (Hz)	High (Hz)	Start (s)	End (s)	Damping (Percent)	Correlation	Damping (Percent)	Correlation
S34E	8*	—	—	—	—	—	—	—	—
S33E	1	1.60	2.20	—	—	—	—	—	—
S33E	2	1.60	2.20	—	—	—	—	—	—
S33E	3	1.60	2.20	—	—	—	—	—	—
S33E	4	1.60	2.20	—	—	—	—	—	—
S33E	5*	—	—	—	—	—	—	—	—
S33E	6	1.60	2.20	—	—	—	—	—	—
S33E	7	1.60	2.20	—	—	—	—	—	—
S32E	1	1.70	2.30	5	50	0.370	0.9865	0.368	0.9861
S32E	2*	—	—	—	—	—	—	—	—
S32E	3	1.70	2.30	—	—	—	—	—	—
S32E	4	1.70	2.30	—	—	—	—	—	—
S32E	5	1.70	2.30	—	—	—	—	—	—
S32E	6	1.70	2.30	—	—	—	—	—	—
S32E	7	1.70	2.30	10	70	0.276	0.9881	0.277	0.9883
S34W	1*	—	—	—	—	—	—	—	—
S34W	2	1.50	2.00	30	160	0.150	0.9969	0.150	0.9969
S34W	3	1.50	2.00	35	160	0.188	0.9971	0.188	0.9971
S34W	4	1.50	2.00	30	100	0.094	0.9973	0.094	0.9973
S34W	5	1.50	2.00	35	170	0.148	0.9962	0.148	0.9962
S34W	6	1.50	2.00	30	110	0.104	0.9926	0.104	0.9925
S34W	7	1.50	2.00	30	140	0.205	0.9983	0.205	0.9983
S34W	8	1.50	2.00	30	180	0.175	0.9989	0.175	0.9989
S33W	1*	—	—	—	—	—	—	—	—
S33W	2	1.50	2.10	—	—	—	—	—	—
S33W	3	1.50	2.10	5	110	0.158	0.9703	0.158	0.9703
S33W	4	1.50	2.10	5	100	0.223	0.9920	0.223	0.9922
S33W	5	1.50	2.10	5	130	0.172	0.9955	0.172	0.9955
S33W	6	1.50	2.10	5	85	0.164	0.9855	0.163	0.9857

Cable	Run	Bandpass Filter		Time Filter		Positive Peaks		Negative Peaks	
		Low (Hz)	High (Hz)	Start (s)	End (s)	Damping (Percent)	Correlation	Damping (Percent)	Correlation
S33W	7	1.50	2.10	5	100	0.171	0.9984	0.171	0.9983
S32W	1*	—	—	—	—	—	—	—	—
S32W	2	1.80	2.30	70	200	0.125	0.9941	0.125	0.9942
S32W	3	1.80	2.30	60	250	0.102	0.9915	0.102	0.9916
S32W	4	1.80	2.30	40	160	0.103	0.9948	0.103	0.9948
S32W	5	1.80	2.30	50	250	0.092	0.9917	0.092	0.9916
S32W	6	1.80	2.30	90	250	0.067	0.9967	0.067	0.9967
S32W	7	1.80	2.30	50	200	0.108	0.9690	0.108	0.9690

*Baseline run.

**Box 2 data corrupted.

—No data available.

Table 18. Phase 1 summary of average damping values.

Cable	Mode	Average Damping Value (Percent)	Max Damping Value^a (Percent)	Min Damping Value^a (Percent)	Correlation	Average Length of Time Sample (s)
N01	1	0.248	0.259	0.236	0.9985	107.9
N02	1	0.299	0.309	0.289	0.9990	92.2
N03	1	0.214	0.218	0.211	0.9977	143.8
N34E	1	0.141	0.150	0.131	0.9950	170.0
N33E	1	0.158	0.173	0.144	0.9992	235.0
N32E	1	0.194	0.201	0.188	0.9984	251.2
N34W	1	0.174	0.186	0.162	0.9990	218.3
N33W	1	0.188	0.197	0.179	0.9993	272.5
N32W	1	0.300	0.324	0.276	0.9983	153.3
S01	1	0.151	0.157	0.144	0.9986	231.5
S02	1	0.190	0.193	0.186	0.9982	217.9
S03	1	0.214	0.217	0.211	0.9994	175.8
S34E	1	0.133	0.139	0.128	0.9989	297.8
S33E	1	0.139	0.150	0.128	0.9991	262.9
S32E	1	0.196	0.207	0.184	0.9981	205.0
S34W	1	0.194	0.206	0.182	0.9975	202.3
S33W	1	0.262	0.287	0.238	0.9978	161.7
S32W	1	0.119	0.126	0.112	0.9985	277.1
N01	2	0.558	0.686	0.429	0.9976	17.8
N02	2	—	—	—	—	—
N03	2	0.274	0.376	0.173	0.9928	51.3
N34E	2	—	—	—	—	—
N33E	2	—	—	—	—	—
N32E	2	0.474	0.539	0.410	0.9956	43.0
N34W	2	0.269	0.336	0.203	0.9911	67.5
N33W	2	0.173	0.182	0.165	0.9971	139.2
N32W	2	0.355	0.395	0.314	0.9917	57.7
S01	2	0.331	0.348	0.315	0.9908	48.0

Cable	Mode	Average Damping Value (Percent)	Max Damping Value^a (Percent)	Min Damping Value^a (Percent)	Correlation	Average Length of Time Sample (s)
S02	2	0.346	0.378	0.313	0.9905	40.4
S03	2	0.164	0.169	0.158	0.9837	81.3
S34E	2	0.189	0.280	0.098	0.9973	125.0
S33E	2	—	—	—	—	—
S32E	2	0.326	0.387	0.265	0.9837	51.3
S34W	2	0.155	0.174	0.135	0.9962	113.1
S33W	2	0.176	0.190	0.162	0.9843	101.0
S32W	2	0.099	0.108	0.089	0.9898	158.3

^aMaximum and minimum values are for the 90-percent confidence interval on the mean.

—No data available.

Table 19. Phase 2, box 1, first-mode damping data.

Cable	Run	Bandpass Filter		Time Filter		Positive Peaks		Negative Peaks	
		Low (Hz)	High (Hz)	Start (s)	End (s)	Damping (Percent)	Correlation	Damping (Percent)	Correlation
N01	1*	—	—	—	—	—	—	—	—
N01	2	0.8	1.6	5	110	0.395	0.9976	0.395	0.9976
N01	3	0.8	1.6	5	100	0.377	0.9966	0.376	0.9965
N01	4	0.8	1.6	5	110	0.354	0.9964	0.354	0.9963
N01	5	0.8	1.6	5	100	0.387	0.9978	0.388	0.9978
N01	6	0.8	1.6	5	90	0.421	0.9987	0.420	0.9987
N01	7	0.8	1.6	5	90	0.389	0.9982	0.388	0.9982
N01	8	0.8	1.6	5	90	0.385	0.9988	0.386	0.9988
N01	9	0.8	1.6	20	120	0.264	0.9875	0.263	0.9872
N02	1*	—	—	—	—	—	—	—	—
N02	2	0.9	1.6	5	110	0.361	0.9993	0.361	0.9993
N02	3	0.9	1.6	5	120	0.367	0.9996	0.367	0.9996
N02	4	0.9	1.6	5	120	0.364	0.9994	0.364	0.9994
N02	5	0.9	1.6	5	120	0.352	0.9991	0.352	0.9991
N02	6	0.9	1.6	5	100	0.365	0.9992	0.366	0.9993
N02	7	0.9	1.6	5	100	0.362	0.9996	0.362	0.9996
N02	8	0.9	1.6	5	100	0.351	0.9996	0.351	0.9996
N02	9	0.9	1.6	5	100	0.355	0.9996	0.355	0.9996
N03	1*	—	—	—	—	—	—	—	—
N03	2	1.1	1.7	5	70	0.456	0.9975	0.457	0.9975
N03	3	1.1	1.7	5	80	0.430	0.9986	0.430	0.9986
N03	4	1.1	1.7	5	80	0.459	0.9982	0.459	0.9981
N03	5	1.1	1.7	5	100	0.445	0.9990	0.445	0.9990
N03	6	1.1	1.7	5	100	0.433	0.9992	0.433	0.9992
N34E	1*	—	—	—	—	—	—	—	—
N34E	2	0.8	1.3	5	100	0.366	0.9958	0.366	0.9956
N34E	3	0.8	1.3	5	110	0.435	0.9996	0.435	0.9996
N34E	4	0.8	1.3	5	120	0.418	0.9993	0.418	0.9993

Cable	Run	Bandpass Filter		Time Filter		Positive Peaks		Negative Peaks	
		Low (Hz)	High (Hz)	Start (s)	End (s)	Damping (Percent)	Correlation	Damping (Percent)	Correlation
N34E	5	0.8	1.3	5	110	0.403	0.9983	0.401	0.9983
N34E	6	0.8	1.3	5	110	0.409	0.9989	0.411	0.9988
N34E	7	0.8	1.3	5	100	0.440	0.9996	0.440	0.9997
N34E	8	0.8	1.3	5	110	0.426	0.9967	0.427	0.9966
N34E	9	0.8	1.3	5	110	0.432	0.9988	0.433	0.9987
N33E	1*	—	—	—	—	—	—	—	—
N33E	2	0.8	1.3	5	150	0.316	0.9983	0.315	0.9984
N33E	3	0.8	1.3	5	150	0.314	0.9988	0.314	0.9989
N33E	4	0.8	1.3	5	150	0.297	0.9992	0.297	0.9992
N33E	5	0.8	1.3	5	150	0.319	0.9992	0.319	0.9993
N33E	6	0.8	1.3	5	180	0.275	0.9985	0.274	0.9986
N33E	7	0.8	1.3	5	150	0.328	0.9986	0.328	0.9988
N33E	8	0.8	1.3	5	180	0.289	0.9997	0.289	0.9997
N33E	9	0.8	1.3	5	180	0.290	0.9997	0.290	0.9997
N32E	1*	—	—	—	—	—	—	—	—
N32E	2	0.8	1.4	5	350	0.103	0.9988	0.103	0.9988
N32E	3	0.8	1.4	5	300	0.090	0.9978	0.090	0.9978
N32E	4	0.8	1.4	5	300	0.100	0.9990	0.100	0.9991
N32E	5	0.8	1.4	5	350	0.100	0.9993	0.101	0.9993
N32E	6	0.8	1.4	5	300	0.103	0.9962	0.103	0.9963
N32E	7	0.8	1.4	5	400	0.100	0.9995	0.100	0.9995
N32E	8	0.8	1.4	5	350	0.103	0.9990	0.103	0.9990
N32E	9	0.8	1.4	5	300	0.097	0.9983	0.097	0.9982
N34W	1*	—	—	—	—	—	—	—	—
N34W	2	0.7	1.2	5	150	0.346	0.9991	0.345	0.9991
N34W	3	0.7	1.2	5	140	0.373	0.9992	0.373	0.9993
N34W	4	0.7	1.2	5	140	0.345	0.9993	0.344	0.9994
N34W	5	0.7	1.2	5	150	0.327	0.9994	0.328	0.9994
N34W	6	0.7	1.2	5	140	0.327	0.9994	0.327	0.9993

Cable	Run	Bandpass Filter		Time Filter		Positive Peaks		Negative Peaks	
		Low (Hz)	High (Hz)	Start (s)	End (s)	Damping (Percent)	Correlation	Damping (Percent)	Correlation
N34W	7	0.7	1.2	5	150	0.298	0.9987	0.299	0.9985
N34W	8*	—	—	—	—	—	—	—	—
N34W	9	0.7	1.2	5	140	0.445	0.9992	0.444	0.9992
N34W	10	0.7	1.2	5	150	0.379	0.9960	0.378	0.9961
N33W	1*	—	—	—	—	—	—	—	—
N33W	2	0.8	1.3	5	130	0.326	0.9992	0.326	0.9993
N33W	3	0.8	1.3	5	120	0.306	0.9992	0.307	0.9991
N33W	4	0.8	1.3	5	130	0.348	0.9994	0.348	0.9995
N33W	5	0.8	1.3	5	150	0.347	0.9996	0.347	0.9996
N33W	6	0.8	1.3	5	150	0.335	0.9994	0.335	0.9994
N33W	7	0.8	1.3	5	130	0.314	0.9991	0.313	0.9993
N33W	8	0.8	1.3	5	150	0.285	0.9986	0.284	0.9987
N33W	9	0.8	1.3	5	135	0.379	0.9992	0.378	0.9992
N32W	1*	—	—	—	—	—	—	—	—
N32W	2	0.8	1.3	5	100	0.298	0.9971	0.300	0.9967
N32W	3	0.8	1.3	5	100	0.252	0.9960	0.252	0.9954
N32W	4	0.8	1.3	5	100	0.281	0.9966	0.283	0.9962
N32W	5	0.8	1.3	5	100	0.299	0.9980	0.298	0.9983
N32W	6	0.8	1.3	5	100	0.289	0.9983	0.290	0.9978
N32W	7	0.8	1.3	5	100	0.297	0.9987	0.298	0.9984
N32W	8	0.8	1.3	5	100	0.291	0.9987	0.292	0.9986
N32W	9	0.8	1.3	5	100	0.251	0.9970	0.252	0.9965
S01	1*	—	—	—	—	—	—	—	—
S01	2	0.9	1.4	5	150	0.272	0.9988	0.271	0.9990
S01	3	0.9	1.5	5	140	0.293	0.9990	0.292	0.9990
S01	4	0.9	1.5	5	150	0.297	0.9994	0.297	0.9994
S01	5	0.9	1.5	5	140	0.300	0.9989	0.300	0.9989
S01	6	0.9	1.5	5	150	0.285	0.9978	0.285	0.9978
S01	7	0.9	1.5	5	150	0.294	0.9978	0.294	0.9979

Cable	Run	Bandpass Filter		Time Filter		Positive Peaks		Negative Peaks	
		Low (Hz)	High (Hz)	Start (s)	End (s)	Damping (Percent)	Correlation	Damping (Percent)	Correlation
S01	8	0.9	1.5	5	140	0.295	0.9986	0.294	0.9985
S01	9	0.9	1.5	5	150	0.265	0.9983	0.265	0.9983
S02	1*	—	—	—	—	—	—	—	—
S02	2	0.9	1.6	5	90	0.502	0.9996	0.503	0.9996
S02	3	0.9	1.6	5	80	0.547	0.9995	0.548	0.9995
S02	4	0.9	1.6	5	100	0.529	0.9993	0.530	0.9993
S02	5	0.9	1.6	5	80	0.581	0.9993	0.581	0.9993
S02	6	0.9	1.6	5	80	0.536	0.9995	0.536	0.9995
S02	7	0.9	1.6	5	80	0.570	0.9994	0.570	0.9994
S02	8	0.9	1.6	5	80	0.536	0.9996	0.537	0.9996
S02	9	0.9	1.6	—	—	—	—	—	—
S03	1*	—	—	—	—	—	—	—	—
S03	2	1.1	1.6	5	100	0.360	0.9991	0.360	0.9990
S03	3	1.1	1.6	5	50	0.536	0.9951	0.538	0.9951
S03	4	1.1	1.6	5	100	0.369	0.9982	0.369	0.9984
S03	5	1.1	1.6	5	100	0.393	0.9974	0.392	0.9975
S03	6	1.1	1.6	5	100	0.376	0.9989	0.377	0.9988
S03	7	1.1	1.6	5	100	0.390	0.9996	0.390	0.9995
S03	8	1.1	1.6	5	100	0.397	0.9997	0.397	0.9997
S03	9	1.1	1.6	5	100	0.371	0.9982	0.373	0.9981
S34E	1*	—	—	—	—	—	—	—	—
S34E	2	0.8	1.3	5	250	0.106	0.9982	0.106	0.9984
S34E	3	0.8	1.3	5	250	0.109	0.9959	0.109	0.9957
S34E	4	0.8	1.3	5	200	0.128	0.9978	0.127	0.9981
S34E	5	0.8	1.3	5	200	0.127	0.9960	0.126	0.9964
S34E	6	0.8	1.3	5	180	0.162	0.9987	0.162	0.9990
S34E	7	0.8	1.3	5	200	0.116	0.9975	0.116	0.9979
S34E	8	0.8	1.3	5	250	0.113	0.9986	0.114	0.9983
S34E	9	0.8	1.3	5	200	0.129	0.9977	0.129	0.9980

Cable	Run	Bandpass Filter		Time Filter		Positive Peaks		Negative Peaks	
		Low (Hz)	High (Hz)	Start (s)	End (s)	Damping (Percent)	Correlation	Damping (Percent)	Correlation
S33E	1*	—	—	—	—	—	—	—	—
S33E	2	0.8	1.4	5	150	0.305	0.9996	0.305	0.9996
S33E	3	0.8	1.4	5	150	0.304	0.9991	0.303	0.9991
S33E	4	0.8	1.4	5	150	0.306	0.9996	0.306	0.9995
S33E	5	0.8	1.4	5	150	0.321	0.9988	0.321	0.9989
S33E	6	0.8	1.4	5	150	0.315	0.9984	0.314	0.9984
S33E	7	0.8	1.4	5	150	0.307	0.9984	0.307	0.9984
S33E	8	0.8	1.4	5	150	0.332	0.9995	0.332	0.9995
S33E	9	0.8	1.4	5	120	0.318	0.9992	0.318	0.9991
S32E	1*	—	—	—	—	—	—	—	—
S32E	2	0.9	1.4	5	110	0.430	0.9996	0.430	0.9996
S32E	3	0.9	1.4	5	150	0.377	0.9993	0.377	0.9993
S32E	4	0.9	1.4	5	150	0.351	0.9980	0.350	0.9981
S32E	5	0.9	1.4	5	100	0.393	0.9991	0.394	0.9989
S32E	6	0.9	1.4	5	110	0.404	0.9996	0.405	0.9995
S32E	7	0.9	1.4	5	110	0.392	0.9990	0.393	0.9989
S32E	8	0.9	1.4	5	120	0.359	0.9991	0.359	0.9989
S32E	9	0.9	1.4	5	120	0.351	0.9996	0.352	0.9995
S34W	1*	—	—	—	—	—	—	—	—
S34W	2	0.7	1.3	5	110	0.323	0.9995	0.323	0.9996
S34W	3	0.7	1.3	5	120	0.342	0.9996	0.342	0.9996
S34W	4	0.7	1.3	5	120	0.345	0.9997	0.345	0.9997
S34W	5	0.7	1.3	5	120	0.326	0.9991	0.326	0.9991
S34W	6	0.7	1.3	5	100	0.357	0.9995	0.356	0.9995
S34W	7	0.7	1.3	5	100	0.346	0.9990	0.346	0.9989
S34W	8	0.7	1.3	—	—	—	—	—	—
S34W	9	0.7	1.3	—	—	—	—	—	—
S33W	1*	—	—	—	—	—	—	—	—
S33W	2	0.8	1.3	5	130	0.326	0.9992	0.326	0.9993

Cable	Run	Bandpass Filter		Time Filter		Positive Peaks		Negative Peaks	
		Low (Hz)	High (Hz)	Start (s)	End (s)	Damping (Percent)	Correlation	Damping (Percent)	Correlation
S33W	3	0.8	1.3	5	110	0.310	0.9994	0.311	0.9992
S33W	4	0.8	1.3	5	120	0.345	0.9995	0.345	0.9996
S33W	5	0.8	1.3	5	150	0.347	0.9996	0.347	0.9996
S33W	6	0.8	1.3	5	130	0.336	0.9997	0.337	0.9996
S33W	7	0.8	1.3	5	120	0.314	0.9992	0.314	0.9994
S33W	8	0.8	1.3	5	150	0.285	0.9986	0.284	0.9987
S33W	9	0.8	1.3	5	150	0.384	0.9990	0.384	0.9990
S32W	1*	—	—	—	—	—	—	—	—
S32W	2	0.9	1.4	5	100	0.503	0.9982	0.503	0.9982
S32W	3	0.9	1.4	5	70	0.434	0.9986	0.432	0.9988
S32W	4	0.9	1.4	—	—	—	—	—	—
S32W	5	0.9	1.4	5	80	0.482	0.9989	0.482	0.9989
S32W	6	0.9	1.4	5	80	0.478	0.9990	0.478	0.9990
S32W	7	0.9	1.4	5	80	0.431	0.9978	0.432	0.9978
S32W	8	0.9	1.4	5	100	0.486	0.9992	0.487	0.9992
S32W	9	0.9	1.4	5	150	0.340	0.9987	0.340	0.9988

*Baseline run.

—No data available.

Table 20. Phase 2, box 2, first-mode damping data.

Cable	Run	Bandpass Filter		Time Filter		Positive Peaks		Negative Peaks	
		Low (Hz)	High (Hz)	Start (s)	End (s)	Damping (Percent)	Correlation	Damping (Percent)	Correlation
N01	1*	—	—	—	—	—	—	—	—
N01	2	0.9	1.5	5	100	0.410	0.9980	0.410	0.9980
N01	3	0.9	1.5	5	90	0.397	0.9974	0.397	0.9974
N01	4	0.9	1.5	5	100	0.370	0.9976	0.370	0.9975
N01	5	0.9	1.5	5	90	0.400	0.9976	0.400	0.9976
N01	6	0.9	1.5	5	100	0.416	0.9984	0.416	0.9984
N01	7	0.9	1.5	5	100	0.387	0.9980	0.387	0.9980
N01	8	0.9	1.5	5	90	0.392	0.9984	0.393	0.9985
N01	9	0.9	1.5	5	100	0.253	0.9908	0.252	0.9911
N02	1*	—	—	—	—	—	—	—	—
N02	2	1	1.6	5	90	0.369	0.9989	0.369	0.9989
N02	3	1	1.6	5	100	0.369	0.9993	0.369	0.9993
N02	4	1	1.6	5	80	0.377	0.9992	0.376	0.9992
N02	5	1	1.6	5	90	0.360	0.9992	0.361	0.9992
N02	6	1	1.6	5	100	0.368	0.9990	0.367	0.9990
N02	7	1	1.6	5	80	0.365	0.9996	0.366	0.9996
N02	8	1	1.6	5	80	0.353	0.9990	0.353	0.9990
N02	9	1	1.6	5	100	0.355	0.9994	0.355	0.9994
N03	1*	—	—	—	—	—	—	—	—
N03	2	1.1	1.8	5	50	0.450	0.9935	0.448	0.9941
N03	3	1.1	1.8	5	60	0.458	0.9987	0.457	0.9987
N03	4	1.1	1.8	5	60	0.489	0.9994	0.489	0.9993
N03	5	1.1	1.8	5	65	0.467	0.9991	0.467	0.9991
N03	6	1.1	1.8	5	65	0.458	0.9992	0.458	0.9992
N34E	1*	—	—	—	—	—	—	—	—
N34E	2	0.8	1.3	5	70	0.416	0.9968	0.418	0.9964
N34E	3	0.8	1.3	5	90	0.450	0.9995	0.449	0.9995
N34E	4	0.8	1.3	5	80	0.425	0.9985	0.426	0.9983

Cable	Run	Bandpass Filter		Time Filter		Positive Peaks		Negative Peaks	
		Low (Hz)	High (Hz)	Start (s)	End (s)	Damping (Percent)	Correlation	Damping (Percent)	Correlation
N34E	5	0.8	1.3	5	90	0.423	0.9989	0.422	0.9990
N34E	6	0.8	1.3	5	100	0.418	0.9979	0.419	0.9979
N34E	7	0.8	1.3	5	90	0.442	0.9991	0.442	0.9992
N34E	8	0.8	1.3	5	80	0.463	0.9967	0.464	0.9966
N34E	9	0.8	1.3	5	110	0.439	0.9964	0.439	0.9964
N33E	1*	—	—	—	—	—	—	—	—
N33E	2	0.8	1.3	5	110	0.327	0.9992	0.327	0.9993
N33E	3	0.8	1.3	5	120	0.326	0.9995	0.326	0.9996
N33E	4	0.8	1.3	5	120	0.307	0.9991	0.306	0.9993
N33E	5	0.8	1.3	5	100	0.329	0.9991	0.328	0.9994
N33E	6	0.8	1.3	5	150	0.285	0.9988	0.285	0.9990
N33E	7	0.8	1.3	5	100	0.342	0.9992	0.341	0.9994
N33E	8	0.8	1.3	5	150	0.288	0.9995	0.288	0.9994
N33E	9	0.8	1.3	5	110	0.294	0.9993	0.295	0.9991
N32E	1*	—	—	—	—	—	—	—	—
N32E	2	0.8	1.4	5	300	0.105	0.9986	0.105	0.9986
N32E	3	0.8	1.4	5	150	0.103	0.9983	0.104	0.9983
N32E	4	0.8	1.4	5	200	0.105	0.9991	0.105	0.9991
N32E	5	0.8	1.4	5	200	0.103	0.9986	0.104	0.9985
N32E	6	0.8	1.4	5	200	0.113	0.9935	0.113	0.9936
N32E	7	0.8	1.4	5	250	0.103	0.9990	0.103	0.9990
N32E	8	0.8	1.4	5	200	0.111	0.9992	0.111	0.9992
N32E	9	0.8	1.4	5	200	0.098	0.9951	0.098	0.9950
N34W	1*	—	—	—	—	—	—	—	—
N34W	2	0.7	1.3	5	100	0.331	0.9993	0.330	0.9993
N34W	3	0.7	1.3	5	100	0.385	0.9990	0.384	0.9990
N34W	4	0.7	1.3	5	120	0.351	0.9993	0.350	0.9993
N34W	5	0.7	1.3	5	100	0.334	0.9989	0.334	0.9989
N34W	6	0.7	1.3	5	120	0.327	0.9985	0.327	0.9985

Cable	Run	Bandpass Filter		Time Filter		Positive Peaks		Negative Peaks	
		Low (Hz)	High (Hz)	Start (s)	End (s)	Damping (Percent)	Correlation	Damping (Percent)	Correlation
N34W	7	0.7	1.3	5	100	0.316	0.9989	0.316	0.9989
N34W	8*	—	—	—	—	—	—	—	—
N34W	9	0.7	1.3	5	80	0.427	0.9990	0.428	0.9991
N34W	10	0.7	1.3	5	80	0.442	0.9986	0.441	0.9986
N33W	1*	—	—	—	—	—	—	—	—
N33W	2	0.8	1.3	5	100	0.325	0.9981	0.324	0.9982
N33W	3	0.8	1.3	5	100	0.312	0.9988	0.313	0.9985
N33W	4	0.8	1.3	5	110	0.345	0.9992	0.345	0.9992
N33W	5	0.8	1.3	5	100	0.341	0.9994	0.342	0.9992
N33W	6	0.8	1.3	5	100	0.338	0.9991	0.338	0.9990
N33W	7	0.8	1.3	5	120	0.313	0.9988	0.312	0.9989
N33W	8	0.8	1.3	5	110	0.299	0.9984	0.298	0.9986
N33W	9	0.8	1.3	5	120	0.371	0.9989	0.370	0.9990
N32W	1*	—	—	—	—	—	—	—	—
N32W	2	0.8	1.3	5	100	0.305	0.9967	0.306	0.9963
N32W	3	0.8	1.3	5	80	0.274	0.9972	0.275	0.9963
N32W	4	0.8	1.3	5	100	0.287	0.9962	0.288	0.9958
N32W	5	0.8	1.3	5	100	0.305	0.9978	0.304	0.9980
N32W	6	0.8	1.3	5	100	0.292	0.9979	0.293	0.9974
N32W	7	0.8	1.3	5	100	0.297	0.9981	0.298	0.9978
N32W	8	0.8	1.3	5	100	0.299	0.9986	0.299	0.9984
N32W	9	0.8	1.3	5	100	0.256	0.9964	0.256	0.9960
S01	1*	—	—	—	—	—	—	—	—
S01	2	0.9	1.4	5	150	0.275	0.9982	0.275	0.9984
S01	3	0.9	1.4	5	130	0.301	0.9989	0.301	0.9990
S01	4	0.9	1.5	5	130	0.304	0.9988	0.304	0.9988
S01	5	0.9	1.5	5	150	0.300	0.9982	0.300	0.9982
S01	6	0.9	1.5	5	110	0.310	0.9983	0.310	0.9983
S01	7	0.9	1.5	5	120	0.315	0.9986	0.315	0.9987

Cable	Run	Bandpass Filter		Time Filter		Positive Peaks		Negative Peaks	
		Low (Hz)	High (Hz)	Start (s)	End (s)	Damping (Percent)	Correlation	Damping (Percent)	Correlation
S01	8	0.9	1.5	5	140	0.301	0.9983	0.301	0.9983
S01	9	0.9	1.5	5	130	0.278	0.9986	0.277	0.9986
S02	1*	—	—	—	—	—	—	—	—
S02	2	1	1.5	5	80	0.505	0.9991	0.504	0.9992
S02	3	1	1.5	5	80	0.544	0.9992	0.543	0.9993
S02	4	1	1.5	5	80	0.541	0.9993	0.540	0.9992
S02	5	1	1.5	5	80	0.562	0.9990	0.561	0.9990
S02	6	1	1.5	5	80	0.526	0.9994	0.525	0.9994
S02	7	1	1.5	5	80	0.564	0.9988	0.564	0.9988
S02	8	1	1.5	5	80	0.539	0.9994	0.538	0.9994
S02	9	1	1.5	—	—	—	—	—	—
S03	1*	—	—	—	—	—	—	—	—
S03	2	1	1.7	5	80	0.375	0.9994	0.374	0.9994
S03	3	1	1.7	5	60	0.516	0.9931	0.515	0.9932
S03	4	1	1.7	5	100	0.374	0.9981	0.374	0.9981
S03	5	1	1.7	5	80	0.414	0.9989	0.414	0.9990
S03	6	1	1.7	5	80	0.391	0.9995	0.391	0.9995
S03	7	1	1.7	5	100	0.387	0.9990	0.387	0.9990
S03	8	1	1.7	5	80	0.406	0.9995	0.405	0.9995
S03	9	1	1.7	5	100	0.372	0.9981	0.372	0.9981
S34E	1*	—	—	—	—	—	—	—	—
S34E	2	0.8	1.4	5	150	0.114	0.9968	0.114	0.9969
S34E	3	0.8	1.4	5	180	0.123	0.9974	0.123	0.9973
S34E	4	0.8	1.4	5	180	0.132	0.9978	0.132	0.9979
S34E	5	0.8	1.4	5	150	0.137	0.9968	0.136	0.9970
S34E	6	0.8	1.4	5	180	0.163	0.9992	0.163	0.9991
S34E	7	0.8	1.4	5	150	0.122	0.9979	0.122	0.9980
S34E	8	0.8	1.4	5	150	0.118	0.9961	0.119	0.9959
S34E	9	0.8	1.4	5	200	0.129	0.9978	0.129	0.9979

Cable	Run	Bandpass Filter		Time Filter		Positive Peaks		Negative Peaks	
		Low (Hz)	High (Hz)	Start (s)	End (s)	Damping (Percent)	Correlation	Damping (Percent)	Correlation
S33E	1*	—	—	—	—	—	—	—	—
S33E	2	0.9	1.4	5	130	0.308	0.9993	0.308	0.9994
S33E	3	0.9	1.4	5	110	0.319	0.9991	0.319	0.9991
S33E	4	0.9	1.4	5	120	0.312	0.9989	0.311	0.9989
S33E	5	0.9	1.4	5	130	0.328	0.9982	0.328	0.9982
S33E	6	0.9	1.4	5	120	0.326	0.9981	0.327	0.9981
S33E	7	0.9	1.4	5	150	0.308	0.9980	0.308	0.9980
S33E	8	0.9	1.4	5	120	0.337	0.9996	0.337	0.9996
S33E	9	0.9	1.4	5	90	0.329	0.9981	0.329	0.9982
S32E	1*	—	—	—	—	—	—	—	—
S32E	2	0.9	1.4	5	100	0.434	0.9995	0.435	0.9994
S32E	3	0.9	1.4	5	100	0.391	0.9991	0.390	0.9992
S32E	4	0.9	1.4	5	80	0.389	0.9985	0.388	0.9988
S32E	5	0.9	1.4	5	100	0.393	0.9987	0.394	0.9985
S32E	6	0.9	1.4	5	80	0.399	0.9992	0.401	0.9989
S32E	7	0.9	1.4	5	80	0.405	0.9990	0.406	0.9988
S32E	8	0.9	1.4	5	80	0.376	0.9986	0.378	0.9982
S32E	9	0.9	1.4	5	90	0.351	0.9989	0.352	0.9987
S34W	1*	—	—	—	—	—	—	—	—
S34W	2	0.8	1.3	5	100	0.324	0.9988	0.323	0.9989
S34W	3	0.8	1.3	5	110	0.346	0.9988	0.347	0.9987
S34W	4	0.8	1.3	5	150	0.343	0.9990	0.342	0.9990
S34W	5	0.8	1.3	5	100	0.326	0.9977	0.326	0.9977
S34W	6	0.8	1.3	5	100	0.357	0.9991	0.357	0.9991
S34W	7	0.8	1.3	5	100	0.347	0.9970	0.346	0.9973
S34W	8	0.8	1.3	—	—	—	—	—	—
S34W	9	0.8	1.3	—	—	—	—	—	—
S33W	1*	—	—	—	—	—	—	—	—
S33W	2	0.8	1.3	5	120	0.324	0.9982	0.324	0.9983

Cable	Run	Bandpass Filter		Time Filter		Positive Peaks		Negative Peaks	
		Low (Hz)	High (Hz)	Start (s)	End (s)	Damping (Percent)	Correlation	Damping (Percent)	Correlation
S33W	3	0.8	1.3	5	100	0.312	0.9988	0.313	0.9985
S33W	4	0.8	1.3	5	100	0.347	0.9991	0.347	0.9992
S33W	5	0.8	1.3	5	110	0.343	0.9994	0.344	0.9993
S33W	6	0.8	1.3	5	100	0.338	0.9991	0.338	0.9990
S33W	7	0.8	1.3	5	140	0.312	0.9991	0.311	0.9992
S33W	8	0.8	1.3	5	110	0.299	0.9984	0.298	0.9986
S33W	9	0.8	1.3	5	120	0.371	0.9989	0.370	0.9990
S32W	1*	—	—	—	—	—	—	—	—
S32W	2	0.9	1.4	5	80	0.483	0.9987	0.483	0.9987
S32W	3	0.9	1.4	5	80	0.452	0.9972	0.451	0.9972
S32W	4	0.9	1.4	—	—	—	—	—	—
S32W	5	0.9	1.4	5	80	0.479	0.9990	0.479	0.9990
S32W	6	0.9	1.4	5	90	0.489	0.9988	0.489	0.9988
S32W	7	0.9	1.4	5	100	0.465	0.9961	0.465	0.9963
S32W	8	0.9	1.4	5	80	0.486	0.9987	0.486	0.9987
S32W	9	0.9	1.4	5	120	0.354	0.9988	0.353	0.9989

*Baseline run.

—No data available.

Table 21. Phase 2, box 1, second-mode damping data.

Cable	Run	Bandpass Filter		Time Filter		Positive Peaks		Negative Peaks	
		Low (Hz)	High (Hz)	Start (s)	End (s)	Damping (Percent)	Correlation	Damping (Percent)	Correlation
N01	1*	—	—	—	—	—	—	—	—
N01	2	2.1	2.7	35	70	0.378	0.9956	0.380	0.9956
N01	3	2.1	2.7	25	70	0.372	0.9958	0.373	0.9959
N01	4	2.1	2.7	35	75	0.379	0.9976	0.380	0.9976
N01	5	2.1	2.7	25	55	0.322	0.9906	0.319	0.9904
N01	6	2.1	2.7	35	75	0.401	0.9971	0.400	0.9970
N01	7	2.1	2.7	30	70	0.391	0.9952	0.390	0.9951
N01	8	2.1	2.7	30	70	0.404	0.9963	0.405	0.9963
N01	9	2.1	2.7	25	70	0.280	0.9830	0.279	0.9827
N02	1*	—	—	—	—	—	—	—	—
N02	2	2.2	2.8	5	70	0.345	0.9940	0.346	0.9939
N02	3	2.2	2.8	5	40	0.360	0.9794	0.360	0.9788
N02	4	2.2	2.8	5	50	0.283	0.9762	0.284	0.9758
N02	5	2.2	2.8	5	60	0.332	0.9936	0.332	0.9935
N02	6	2.2	2.8	5	50	0.257	0.9879	0.257	0.9875
N02	7	2.2	2.8	5	50	0.294	0.9876	0.291	0.9887
N02	8	2.2	2.8	5	50	0.286	0.9924	0.287	0.9921
N02	9	2.2	2.8	5	55	0.301	0.9915	0.302	0.9912
N03	1*	—	—	—	—	—	—	—	—
N03	2	2.5	3.2	5	30	0.597	0.9818	0.599	0.9815
N03	3	2.5	3.2	5	30	0.693	0.9939	0.694	0.9939
N03	4	2.5	3.2	5	35	0.546	0.9985	0.546	0.9986
N03	5	2.5	3.2	5	30	0.586	0.9950	0.588	0.9948
N03	6	2.5	3.2	5	35	0.568	0.9980	0.569	0.9979
N34E	1*	—	—	—	—	—	—	—	—
N34E	2	1.7	2.4	5	50	0.218	0.9909	0.216	0.9904
N34E	3	1.7	2.4	5	60	0.183	0.9938	0.183	0.9939
N34E	4	1.7	2.4	5	60	0.311	0.9963	0.312	0.9967

Cable	Run	Bandpass Filter		Time Filter		Positive Peaks		Negative Peaks	
		Low (Hz)	High (Hz)	Start (s)	End (s)	Damping (Percent)	Correlation	Damping (Percent)	Correlation
N34E	5	1.7	2.4	5	55	0.298	0.9972	0.299	0.9973
N34E	6	1.7	2.4	5	45	0.204	0.9931	0.202	0.9918
N34E	7	1.7	2.4	5	65	0.245	0.9928	0.246	0.9930
N34E	8	1.7	2.4	5	45	0.213	0.9933	0.214	0.9943
N34E	9	1.7	2.4	5	60	0.277	0.9977	0.277	0.9975
N33E	1*	—	—	—	—	—	—	—	—
N33E	2	1.8	2.3	5	60	0.246	0.9974	0.246	0.9970
N33E	3	1.8	2.3	5	100	0.214	0.9979	0.214	0.9978
N33E	4	1.8	2.3	5	70	0.232	0.9984	0.232	0.9985
N33E	5	1.8	2.3	5	80	0.201	0.9975	0.201	0.9975
N33E	6	1.7	2.4	5	40	0.233	0.9983	0.234	0.9987
N33E	7	1.7	2.4	5	70	0.280	0.9984	0.280	0.9982
N33E	8	1.8	2.4	5	60	0.162	0.9956	0.163	0.9956
N33E	9	1.8	2.4	5	110	0.205	0.9992	0.205	0.9992
N32E	1*	—	—	—	—	—	—	—	—
N32E	2	1.9	2.4	10	60	0.162	0.9977	0.162	0.9977
N32E	3	1.9	2.4	5	70	0.155	0.9963	0.155	0.9958
N32E	4	1.9	2.4	5	60	0.152	0.9940	0.153	0.9935
N32E	5	1.9	2.4	5	120	0.142	0.9919	0.142	0.9921
N32E	6	1.9	2.4	10	70	0.208	0.9974	0.208	0.9974
N32E	7	1.9	2.4	10	90	0.137	0.9938	0.137	0.9937
N32E	8	1.9	2.4	5	70	0.162	0.9912	0.161	0.9919
N32E	9	1.9	2.4	10	50	0.174	0.9988	0.174	0.9988
N34W	1*	—	—	—	—	—	—	—	—
N34W	2	1.7	2.2	5	80	0.288	0.9976	0.287	0.9979
N34W	3	1.7	2.2	5	70	0.368	0.9969	0.368	0.9967
N34W	4	1.7	2.2	5	70	0.372	0.9978	0.373	0.9975
N34W	5	1.7	2.2	5	60	0.286	0.9973	0.288	0.9971
N34W	6	1.7	2.2	5	80	0.329	0.9965	0.328	0.9967

Cable	Run	Bandpass Filter		Time Filter		Positive Peaks		Negative Peaks	
		Low (Hz)	High (Hz)	Start (s)	End (s)	Damping (Percent)	Correlation	Damping (Percent)	Correlation
N34W	7	1.7	2.2	5	70	0.315	0.9985	0.315	0.9987
N34W	8*	—	—	—	—	—	—	—	—
N34W	9	1.7	2.2	5	50	0.528	0.9985	0.529	0.9984
N34W	10	1.7	2.2	5	50	0.343	0.9964	0.341	0.9968
N33W	1*	—	—	—	—	—	—	—	—
N33W	2	1.8	2.4	5	55	0.273	0.9982	0.273	0.9982
N33W	3	1.8	2.4	5	70	0.276	0.9947	0.276	0.9946
N33W	4	1.8	2.4	5	50	0.384	0.9956	0.384	0.9956
N33W	5	1.8	2.4	5	50	0.388	0.9988	0.388	0.9990
N33W	6	1.8	2.4	5	70	0.380	0.9983	0.379	0.9983
N33W	7	1.8	2.4	5	60	0.334	0.9987	0.334	0.9987
N33W	8	1.8	2.4	—	—	—	—	—	—
N33W	9	1.8	2.4	5	60	0.458	0.9983	0.458	0.9983
N32W	1*	—	—	—	—	—	—	—	—
N32W	2	1.8	2.4	5	80	0.197	0.9958	0.196	0.9958
N32W	3	1.8	2.4	5	70	0.194	0.9920	0.194	0.9918
N32W	4	1.8	2.4	5	70	0.208	0.9895	0.208	0.9895
N32W	5	1.8	2.4	5	70	0.194	0.9961	0.193	0.9961
N32W	6	1.8	2.4	5	80	0.237	0.9969	0.237	0.9968
N32W	7	1.8	2.4	5	70	0.223	0.9942	0.223	0.9940
N32W	8	1.8	2.4	10	60	0.136	0.9883	0.136	0.9883
N32W	9	1.8	2.4	5	70	0.194	0.9948	0.193	0.9948
S01	1*	—	—	—	—	—	—	—	—
S01	2	2	2.7	—	—	—	—	—	—
S01	3	2	2.7	—	—	—	—	—	—
S01	4	2	2.7	—	—	—	—	—	—
S01	5	2	2.7	—	—	—	—	—	—
S01	6	2	2.7	—	—	—	—	—	—
S01	7	2	2.7	—	—	—	—	—	—

Cable	Run	Bandpass Filter		Time Filter		Positive Peaks		Negative Peaks	
		Low (Hz)	High (Hz)	Start (s)	End (s)	Damping (Percent)	Correlation	Damping (Percent)	Correlation
S01	8	2	2.7	—	—	—	—	—	—
S01	9	2	2.7	—	—	—	—	—	—
S02	1*	—	—	—	—	—	—	—	—
S02	2	2	2.8	5	60	0.298	0.9966	0.298	0.9966
S02	3	2	2.8	5	80	0.259	0.9978	0.258	0.9978
S02	4	2	2.8	5	50	0.233	0.9917	0.233	0.9917
S02	5	2	2.8	5	60	0.265	0.9871	0.264	0.9869
S02	6	2	2.8	5	50	0.217	0.9909	0.219	0.9908
S02	7	2	2.8	5	70	0.277	0.9983	0.276	0.9982
S02	8	2	2.8	5	60	0.224	0.9781	0.223	0.9785
S02	9	2	2.8	—	—	—	—	—	—
S03	1*	—	—	—	—	—	—	—	—
S03	2	2.4	2.9	5	60	0.416	0.9985	0.416	0.9985
S03	3	2.4	2.9	5	50	0.327	0.9769	0.329	0.9769
S03	4	2.4	2.9	5	60	0.425	0.9982	0.424	0.9983
S03	5	2.4	2.9	5	60	0.367	0.9981	0.367	0.9981
S03	6	2.4	2.9	5	55	0.384	0.9963	0.384	0.9963
S03	7	2.4	2.9	5	60	0.396	0.9983	0.395	0.9983
S03	8	2.4	2.9	5	60	0.397	0.9980	0.397	0.9979
S03	9	2.4	2.9	5	60	0.417	0.9993	0.417	0.9993
S34E	1*	—	—	—	—	—	—	—	—
S34E	2	1.9	2.4	—	—	—	—	—	—
S34E	3	1.9	2.4	—	—	—	—	—	—
S34E	4	1.9	2.4	—	—	—	—	—	—
S34E	5	1.9	2.4	—	—	—	—	—	—
S34E	6	1.9	2.4	—	—	—	—	—	—
S34E	7	1.9	2.4	—	—	—	—	—	—
S34E	8	1.9	2.4	5	75	0.191	0.9912	0.192	0.9904
S34E	9	1.9	2.4	—	—	—	—	—	—

Cable	Run	Bandpass Filter		Time Filter		Positive Peaks		Negative Peaks	
		Low (Hz)	High (Hz)	Start (s)	End (s)	Damping (Percent)	Correlation	Damping (Percent)	Correlation
S33E	1*	—	—	—	—	—	—	—	—
S33E	2	1.9	2.5	5	60	0.238	0.9987	0.239	0.9987
S33E	3	1.9	2.5	5	80	0.257	0.9986	0.257	0.9986
S33E	4	1.9	2.5	5	70	0.256	0.9981	0.256	0.9981
S33E	5	1.9	2.5	5	80	0.258	0.9991	0.258	0.9991
S33E	6	1.9	2.5	5	80	0.263	0.9983	0.263	0.9983
S33E	7	1.9	2.5	5	50	0.256	0.9973	0.256	0.9973
S33E	8	1.9	2.5	5	70	0.273	0.9982	0.273	0.9982
S33E	9	1.9	2.5	5	80	0.266	0.9979	0.266	0.9979
S32E	1*	—	—	—	—	—	—	—	—
S32E	2	2	2.7	—	—	—	—	—	—
S32E	3	2	2.6	—	—	—	—	—	—
S32E	4	2	2.6	5	80	0.185	0.9783	0.185	0.9783
S32E	5	2	2.6	5	60	0.162	0.9609	0.162	0.9609
S32E	6	2	2.6	5	60	0.177	0.9793	0.177	0.9792
S32E	7	2	2.6	5	80	0.162	0.9868	0.163	0.9863
S32E	8	2	2.6	5	60	0.194	0.9775	0.194	0.9774
S32E	9	2	2.6	5	60	0.246	0.9853	0.247	0.9847
S34W	1*	—	—	—	—	—	—	—	—
S34W	2	1.7	2.3	5	100	0.139	0.9648	0.140	0.9654
S34W	3	1.7	2.3	5	100	0.138	0.9630	0.137	0.9633
S34W	4	1.7	2.3	—	—	—	—	—	—
S34W	5	1.7	2.3	—	—	—	—	—	—
S34W	6	1.7	2.3	—	—	—	—	—	—
S34W	7	1.7	2.3	5	80	0.286	0.9954	0.286	0.9953
S34W	8	1.7	2.3	—	—	—	—	—	—
S34W	9	1.7	2.3	—	—	—	—	—	—
S33W	1*	—	—	—	—	—	—	—	—
S33W	2	1.8	2.4	5	55	0.273	0.9982	0.273	0.9982

Cable	Run	Bandpass Filter		Time Filter		Positive Peaks		Negative Peaks	
		Low (Hz)	High (Hz)	Start (s)	End (s)	Damping (Percent)	Correlation	Damping (Percent)	Correlation
S33W	3	1.8	2.4	5	60	0.290	0.9962	0.289	0.9962
S33W	4	1.8	2.4	5	50	0.384	0.9956	0.384	0.9956
S33W	5	1.8	2.4	5	55	0.385	0.9987	0.383	0.9988
S33W	6	1.8	2.4	5	70	0.380	0.9983	0.379	0.9983
S33W	7	1.8	2.4	5	70	0.318	0.9965	0.318	0.9965
S33W	8	1.8	2.4	—	—	—	—	—	—
S33W	9	1.8	2.4	5	60	0.458	0.9983	0.458	0.9983
S32W	1*	—	—	—	—	—	—	—	—
S32W	2	2	2.5	5	60	0.248	0.9975	0.248	0.9976
S32W	3	2	2.6	5	80	0.215	0.9966	0.215	0.9968
S32W	4	2	2.6	—	—	—	—	—	—
S32W	5	2	2.6	5	70	0.303	0.9984	0.303	0.9983
S32W	6	2	2.6	5	80	0.281	0.9989	0.281	0.9989
S32W	7	2	2.6	5	80	0.248	0.9982	0.248	0.9982
S32W	8	2	2.6	5	70	0.289	0.9979	0.289	0.9979
S32W	9	2	2.6	5	100	0.219	0.9967	0.219	0.9967

*Baseline run.

—No data available.

Table 22. Phase 2, box 2, second-mode damping data.

Cable	Run	Bandpass Filter		Time Filter		Positive Peaks		Negative Peaks	
		Low (Hz)	High (Hz)	Start (s)	End (s)	Damping (Percent)	Correlation	Damping (Percent)	Correlation
N01	1*	—	—	—	—	—	—	—	—
N01	2	2.1	2.7	35	75	0.392	0.9961	0.393	0.9961
N01	3	2.1	2.7	30	80	0.421	0.9943	0.421	0.9943
N01	4	2.1	2.7	30	70	0.363	0.9952	0.364	0.9953
N01	5	2.1	2.7	30	55	0.357	0.9921	0.356	0.9924
N01	6	2.1	2.7	30	70	0.376	0.9943	0.378	0.9945
N01	7	2.1	2.7	30	80	0.414	0.9964	0.414	0.9963
N01	8	2.1	2.7	30	70	0.395	0.9970	0.396	0.9971
N01	9	2.1	2.7	30	65	0.304	0.9836	0.303	0.9843
N02	1*	—	—	—	—	—	—	—	—
N02	2	2.3	2.8	5	60	0.365	0.9917	0.366	0.9914
N02	3	2.3	2.8	5	40	0.373	0.9821	0.376	0.9813
N02	4	2.3	2.8	5	50	0.317	0.9794	0.319	0.9787
N02	5	2.3	2.8	5	50	0.341	0.9871	0.342	0.9868
N02	6	2.3	2.8	5	50	0.282	0.9844	0.280	0.9852
N02	7	2.3	2.8	5	55	0.307	0.9878	0.306	0.9884
N02	8	2.3	2.8	5	55	0.305	0.9908	0.307	0.9904
N02	9	2.3	2.8	5	45	0.339	0.9877	0.341	0.9869
N03	1*	—	—	—	—	—	—	—	—
N03	2	2.5	3.2	5	30	0.559	0.9762	0.550	0.9810
N03	3	2.5	3.2	5	30	0.677	0.9932	0.676	0.9935
N03	4	2.5	3.2	5	45	0.599	0.9960	0.600	0.9959
N03	5	2.5	3.2	5	30	0.540	0.9985	0.541	0.9985
N03	6	2.5	3.2	5	40	0.541	0.9941	0.541	0.9939
N34E	1*	—	—	—	—	—	—	—	—
N34E	2	1.8	2.3	10	55	0.236	0.9889	0.237	0.9889
N34E	3	1.8	2.3	5	70	0.191	0.9929	0.191	0.9924
N34E	4	1.8	2.3	5	70	0.305	0.9981	0.305	0.9981

Cable	Run	Bandpass Filter		Time Filter		Positive Peaks		Negative Peaks	
		Low (Hz)	High (Hz)	Start (s)	End (s)	Damping (Percent)	Correlation	Damping (Percent)	Correlation
N34E	5	1.8	2.3	5	60	0.302	0.9948	0.301	0.9949
N34E	6	1.8	2.3	5	80	0.265	0.9902	0.265	0.9904
N34E	7	1.8	2.3	5	70	0.249	0.9913	0.249	0.9913
N34E	8	1.8	2.3	5	50	0.231	0.9830	0.228	0.9843
N34E	9	1.8	2.3	5	80	0.268	0.9982	0.268	0.9981
N33E	1*	—	—	—	—	—	—	—	—
N33E	2	1.8	2.3	5	100	0.213	0.9951	0.213	0.9950
N33E	3	1.8	2.3	5	100	0.211	0.9981	0.211	0.9980
N33E	4	1.8	2.3	5	75	0.235	0.9977	0.235	0.9977
N33E	5	1.8	2.3	5	80	0.198	0.9970	0.198	0.9969
N33E	6	1.8	2.3	5	80	0.226	0.9962	0.226	0.9961
N33E	7	1.8	2.3	5	80	0.266	0.9982	0.267	0.9983
N33E	8	1.8	2.3	5	60	0.162	0.9925	0.163	0.9919
N33E	9	1.8	2.3	5	120	0.201	0.9989	0.201	0.9989
N32E	1*	—	—	—	—	—	—	—	—
N32E	2	1.9	2.4	5	60	0.166	0.9931	0.165	0.9940
N32E	3	1.9	2.4	5	70	0.154	0.9950	0.154	0.9944
N32E	4	1.9	2.4	5	70	0.147	0.9927	0.147	0.9922
N32E	5	1.9	2.4	5	60	0.184	0.9942	0.183	0.9948
N32E	6	1.9	2.4	5	80	0.203	0.9951	0.203	0.9953
N32E	7	1.9	2.4	5	80	0.144	0.9930	0.144	0.9926
N32E	8	1.9	2.4	5	80	0.153	0.9891	0.153	0.9896
N32E	9	1.9	2.4	5	50	0.180	0.9954	0.181	0.9946
N34W	1*	—	—	—	—	—	—	—	—
N34W	2	1.7	2.2	5	60	0.302	0.9968	0.301	0.9971
N34W	3	1.7	2.2	5	60	0.377	0.9964	0.377	0.9960
N34W	4	1.7	2.2	5	60	0.372	0.9969	0.373	0.9966
N34W	5	1.7	2.2	5	80	0.306	0.9979	0.307	0.9979
N34W	6	1.7	2.2	5	80	0.338	0.9971	0.338	0.9973

Cable	Run	Bandpass Filter		Time Filter		Positive Peaks		Negative Peaks	
		Low (Hz)	High (Hz)	Start (s)	End (s)	Damping (Percent)	Correlation	Damping (Percent)	Correlation
N34W	7	1.7	2.2	5	70	0.313	0.9983	0.312	0.9985
N34W	8*	—	—	—	—	—	—	—	—
N34W	9	1.7	2.2	5	60	0.498	0.9974	0.500	0.9973
N34W	10	1.7	2.2	5	50	0.342	0.9960	0.340	0.9963
N33W	1*	—	—	—	—	—	—	—	—
N33W	2	1.8	2.4	5	60	0.290	0.9929	0.289	0.9933
N33W	3	1.8	2.4	5	60	0.291	0.9966	0.290	0.9966
N33W	4	1.8	2.4	5	50	0.383	0.9938	0.384	0.9941
N33W	5	1.8	2.4	5	60	0.396	0.9985	0.396	0.9985
N33W	6	1.8	2.4	5	60	0.387	0.9969	0.387	0.9969
N33W	7	1.8	2.4	5	60	0.332	0.9988	0.332	0.9988
N33W	8	1.8	2.4	—	—	—	—	—	—
N33W	9	1.8	2.4	5	50	0.476	0.9982	0.475	0.9982
N32W	1*	—	—	—	—	—	—	—	—
N32W	2	1.8	2.4	5	80	0.198	0.9963	0.198	0.9964
N32W	3	1.8	2.4	5	70	0.196	0.9921	0.196	0.9920
N32W	4	1.8	2.4	5	60	0.193	0.9903	0.193	0.9904
N32W	5	1.8	2.4	5	60	0.186	0.9975	0.186	0.9975
N32W	6	1.8	2.4	5	70	0.229	0.9983	0.230	0.9982
N32W	7	1.8	2.4	5	80	0.237	0.9937	0.237	0.9936
N32W	8	1.8	2.4	10	60	0.135	0.9903	0.136	0.9902
N32W	9	1.8	2.4	5	70	0.194	0.9950	0.194	0.9950
S01	1*	—	—	—	—	—	—	—	—
S01	2	2	2.7	—	—	—	—	—	—
S01	3	2	2.7	—	—	—	—	—	—
S01	4	2	2.7	—	—	—	—	—	—
S01	5	2	2.7	—	—	—	—	—	—
S01	6	2	2.7	—	—	—	—	—	—
S01	7	2	2.7	—	—	—	—	—	—

Cable	Run	Bandpass Filter		Time Filter		Positive Peaks		Negative Peaks	
		Low (Hz)	High (Hz)	Start (s)	End (s)	Damping (Percent)	Correlation	Damping (Percent)	Correlation
S01	8	2	2.7	—	—	—	—	—	—
S01	9	2	2.7	—	—	—	—	—	—
S02	1*	—	—	—	—	—	—	—	—
S02	2	2	2.8	5	50	0.324	0.9969	0.323	0.9968
S02	3	2.1	2.8	5	80	0.263	0.9969	0.262	0.9970
S02	4	2.1	2.8	5	60	0.238	0.9923	0.239	0.9925
S02	5	2.1	2.8	5	60	0.255	0.9875	0.255	0.9873
S02	6	2.1	2.8	5	40	0.235	0.9910	0.235	0.9911
S02	7	2.1	2.8	5	70	0.269	0.9971	0.269	0.9970
S02	8	2.1	2.8	5	60	0.221	0.9744	0.221	0.9744
S02	9	2.1	2.8	—	—	—	—	—	—
S03	1*	—	—	—	—	—	—	—	—
S03	2	2.4	2.9	5	60	0.419	0.9981	0.419	0.9981
S03	3	2.4	2.9	—	—	—	—	—	—
S03	4	2.4	2.9	5	50	0.433	0.9985	0.432	0.9986
S03	5	2.4	2.9	5	50	0.364	0.9990	0.364	0.9990
S03	6	2.4	2.9	5	55	0.388	0.9958	0.388	0.9959
S03	7	2.4	2.9	5	70	0.394	0.9982	0.394	0.9982
S03	8	2.4	2.9	5	50	0.392	0.9981	0.391	0.9980
S03	9	2.4	2.9	5	70	0.411	0.9990	0.411	0.9990
S34E	1*	—	—	—	—	—	—	—	—
S34E	2	1.8	2.3	—	—	—	—	—	—
S34E	3	1.8	2.3	—	—	—	—	—	—
S34E	4	1.8	2.3	—	—	—	—	—	—
S34E	5	1.8	2.3	—	—	—	—	—	—
S34E	6	1.8	2.3	—	—	—	—	—	—
S34E	7	1.8	2.3	—	—	—	—	—	—
S34E	8	1.8	2.3	5	60	0.221	0.9922	0.220	0.9930
S34E	9	1.8	2.3	—	—	—	—	—	—

Cable	Run	Bandpass Filter		Time Filter		Positive Peaks		Negative Peaks	
		Low (Hz)	High (Hz)	Start (s)	End (s)	Damping (Percent)	Correlation	Damping (Percent)	Correlation
S33E	1*	—	—	—	—	—	—	—	—
S33E	2	2	2.5	5	70	0.234	0.9979	0.234	0.9977
S33E	3	2	2.5	5	80	0.256	0.9992	0.256	0.9992
S33E	4	2	2.5	5	70	0.258	0.9979	0.258	0.9979
S33E	5	2	2.5	5	80	0.262	0.9994	0.262	0.9993
S33E	6	2	2.5	5	70	0.265	0.9986	0.265	0.9985
S33E	7	1.9	2.5	5	50	0.256	0.9972	0.256	0.9973
S33E	8	1.9	2.5	5	80	0.266	0.9970	0.265	0.9969
S33E	9	1.9	2.5	5	80	0.270	0.9965	0.270	0.9965
S32E	1*	—	—	—	—	—	—	—	—
S32E	2	2	2.6	—	—	—	—	—	—
S32E	3	2	2.6	—	—	—	—	—	—
S32E	4	2	2.6	5	80	0.183	0.9767	0.183	0.9766
S32E	5	2	2.6	5	60	0.170	0.9693	0.171	0.9688
S32E	6	2	2.6	5	60	0.183	0.9794	0.183	0.9794
S32E	7	2	2.6	5	80	0.159	0.9796	0.160	0.9792
S32E	8	2	2.6	5	60	0.197	0.9763	0.197	0.9770
S32E	9	2	2.6	5	60	0.248	0.9834	0.250	0.9829
S34W	1*	—	—	—	—	—	—	—	—
S34W	2	1.7	2.3	—	—	—	—	—	—
S34W	3	1.7	2.3	—	—	—	—	—	—
S34W	4	1.7	2.3	—	—	—	—	—	—
S34W	5	1.7	2.3	—	—	—	—	—	—
S34W	6	1.7	2.3	—	—	—	—	—	—
S34W	7	1.7	2.3	5	70	0.302	0.9961	0.301	0.9956
S34W	8	1.7	2.3	—	—	—	—	—	—
S34W	9	1.7	2.3	—	—	—	—	—	—
S33W	1*	—	—	—	—	—	—	—	—
S33W	2	1.8	2.4	5	55	0.278	0.9964	0.278	0.9964

Cable	Run	Bandpass Filter		Time Filter		Positive Peaks		Negative Peaks	
		Low (Hz)	High (Hz)	Start (s)	End (s)	Damping (Percent)	Correlation	Damping (Percent)	Correlation
S33W	3	1.8	2.4	5	60	0.291	0.9966	0.290	0.9966
S33W	4	1.8	2.4	5	50	0.383	0.9938	0.384	0.9941
S33W	5	1.8	2.4	5	55	0.389	0.9988	0.389	0.9988
S33W	6	1.8	2.4	5	65	0.384	0.9974	0.383	0.9974
S33W	7	1.8	2.4	5	80	0.320	0.9964	0.320	0.9964
S33W	8	1.8	2.4	—	—	—	—	—	—
S33W	9	1.8	2.4	5	65	0.456	0.9981	0.456	0.9981
S32W	1*	—	—	—	—	—	—	—	—
S32W	2	2	2.6	5	70	0.255	0.9982	0.255	0.9982
S32W	3	2	2.6	5	70	0.218	0.9962	0.218	0.9963
S32W	4	2	2.6	—	—	—	—	—	—
S32W	5	2	2.6	5	70	0.302	0.9985	0.302	0.9985
S32W	6	2	2.6	5	70	0.271	0.9994	0.271	0.9994
S32W	7	2	2.6	5	60	0.238	0.9978	0.238	0.9978
S32W	8	2	2.6	5	70	0.292	0.9974	0.292	0.9974
S32W	9	2	2.6	5	80	0.231	0.9983	0.231	0.9983

*Baseline run.

—No data available.

Table 23. Phase 2 summary of average damping values.

Cable	Mode	Average Damping Value (Percent)	Max Damping Value¹ (Percent)	Min Damping Value¹ (Percent)	Correlation	Average Length of Time Sample (s)
N01	1	0.375	0.396	0.354	0.9967	92.8
N02	1	0.362	0.365	0.359	0.9993	94.4
N03	1	0.455	0.464	0.445	0.9982	68.0
N34E	1	0.425	0.435	0.416	0.9982	93.8
N33E	1	0.308	0.317	0.299	0.9991	135.6
N32E	1	0.102	0.105	0.100	0.9981	266.9
N34W	1	0.360	0.379	0.340	0.9989	117.5
N33W	1	0.330	0.341	0.319	0.9990	117.2
N32W	1	0.286	0.294	0.278	0.9975	93.8
S01	1	0.293	0.299	0.287	0.9985	134.4
S02	1	0.542	0.552	0.531	0.9993	77.1
S03	1	0.402	0.424	0.379	0.9982	84.4
S34E	1	0.127	0.134	0.120	0.9975	186.9
S33E	1	0.317	0.322	0.312	0.9989	128.8
S32E	1	0.387	0.399	0.376	0.9990	100.0
S34W	1	0.340	0.347	0.334	0.9989	105.8
S33W	1	0.331	0.342	0.320	0.9991	117.5
S32W	1	0.455	0.478	0.431	0.9984	87.1
N01	2	0.372	0.389	0.355	0.9938	39.7
N02	2	0.318	0.333	0.303	0.9871	46.9
N03	2	0.591	0.622	0.559	0.9925	28.5
N34E	2	0.250	0.268	0.232	0.9933	55.6
N33E	2	0.218	0.232	0.204	0.9973	75.3
N32E	2	0.164	0.173	0.155	0.9943	65.0
N34W	2	0.355	0.385	0.325	0.9973	60.6
N33W	2	0.361	0.391	0.330	0.9970	53.2
N32W	2	0.197	0.210	0.184	0.9938	64.4
S01	2	—	—	—	—	—

Cable	Mode	Average Damping Value (Percent)	Max Damping Value¹ (Percent)	Min Damping Value¹ (Percent)	Correlation	Average Length of Time Sample (s)
S02	2	0.255	0.270	0.241	0.9912	55.7
S03	2	0.395	0.408	0.383	0.9967	53.0
S34E	2	0.206	0.301	0.112	0.9917	62.5
S33E	2	0.258	0.263	0.254	0.9981	66.9
S32E	2	0.189	0.204	0.173	0.9777	61.7
S34W	2	0.216	0.322	0.110	0.9798	82.5
S33W	2	0.356	0.385	0.327	0.9971	55.7
S32W	2	0.258	0.273	0.243	0.9979	68.6

¹Maximum and minimum values are for the 90-percent confidence interval on the mean.

—No data available.

Table 24. Phase 3, box 1, first-mode damping data.

Cable	Run	Bandpass Filter		Time Filter		Positive Peaks		Negative Peaks	
		Low (Hz)	High (Hz)	Start (s)	End (s)	Damping (Percent)	Correlation	Damping (Percent)	Correlation
N01	1*	—	—	—	—	—	—	—	—
N01	2	2.7	3.4	29	50	0.661	0.9867	0.655	0.9885
N01	3	2.2	3.5	49	65	0.827	0.9956	0.824	0.9958
N01	4	2.5	3.5	64	85	0.627	0.9909	0.622	0.9893
N01	5	2.5	3.5	33	53	0.729	0.9970	0.728	0.9972
N01	6	2.5	3.5	47	63	0.740	0.9817	0.753	0.9822
N01	7	2.5	3.5	—	—	—	—	—	—
N01	8	2.5	3.3	35	65	0.597	0.9909	0.593	0.9905
N01	9	2.5	3.5	16	35	0.718	0.9988	0.721	0.9990
N02	1*	—	—	—	—	—	—	—	—
N02	2	2.5	3.6	56	70	0.718	0.9884	0.714	0.9886
N02	3	2.1	3.9	30	46	0.675	0.9896	0.684	0.9893
N02	4	2.3	3.7	—	—	—	—	—	—
N02	5	2.3	3.7	44	60	0.620	0.9919	0.617	0.9921
N02	6	2.3	3.7	52	68	0.669	0.9919	0.665	0.9910
N02	7	2.3	3.7	84	100	0.639	0.9580	0.640	0.9590
N02	8	2.3	3.7	23	35	0.730	0.9669	0.724	0.9641
N02	9	2.3	3.7	—	—	—	—	—	—
N03	1*	—	—	—	—	—	—	—	—
N03	2	—	—	—	—	—	—	—	—
N03	3	—	—	—	—	—	—	—	—
N03	4	—	—	—	—	—	—	—	—
N03	5	—	—	—	—	—	—	—	—
N03	6	—	—	—	—	—	—	—	—
N03	7	4.0	6.2	—	—	—	—	—	—
N03	8	4.0	6.0	58	75	0.813	0.9473	0.804	0.9413
N03	9	3.0	6.0	45	60	0.779	0.9027	0.771	0.8810
N34E	1*	—	—	—	—	—	—	—	—

Cable	Run	Bandpass Filter		Time Filter		Positive Peaks		Negative Peaks	
		Low (Hz)	High (Hz)	Start (s)	End (s)	Damping (Percent)	Correlation	Damping (Percent)	Correlation
N34E	2	1.7	2.8	22	33	1.828	0.9955	1.845	0.9957
N34E	3	1.5	3.0	15	26	2.438	0.9921	2.454	0.9928
N34E	4	1.5	3.0	18	30	2.300	0.9947	2.321	0.9947
N34E	5	1.5	3.0	13	24	2.087	0.9954	2.065	0.9964
N34E	6	1.5	3.0	16	28	1.916	0.9896	1.883	0.9911
N34E	7	1.5	3.0	18	31	1.868	0.9870	1.817	0.9916
N34E	8	1.5	3.0	10	25	1.338	0.9950	1.334	0.9954
N34E	9	1.5	3.0	13	25	1.988	0.9950	2.004	0.9941
N33E	1*	—	—	—	—	—	—	—	—
N33E	2	1.5	3.3	62	70	1.905	0.9723	1.862	0.9697
N33E	3	1.5	3.3	38	50	1.576	0.9804	1.605	0.9816
N33E	4	1.5	3.3	10	22	1.399	0.9727	1.401	0.9721
N33E	5	1.5	3.3	—	—	—	—	—	—
N33E	6	1.5	3.3	—	—	—	—	—	—
N33E	7	1.5	3.3	10	20	1.837	0.9976	1.825	0.9976
N33E	8	1.5	3.3	12	24	1.586	0.9911	1.598	0.9922
N33E	9	1.5	3.3	8	20	1.597	0.9910	1.576	0.9905
N32E	1*	—	—	—	—	—	—	—	—
N32E	2	1.8	3.7	41	70	0.650	0.9945	0.650	0.9946
N32E	3	1.8	3.7	21	45	0.724	0.9888	0.723	0.9891
N32E	4	1.8	3.7	—	—	—	—	—	—
N32E	5	1.8	3.7	24	50	0.691	0.9920	0.693	0.9920
N32E	6	1.8	3.7	26	50	0.673	0.9942	0.669	0.9943
N32E	7	1.8	3.7	18	40	0.677	0.9837	0.680	0.9840
N32E	8	1.8	3.7	15	40	0.670	0.9863	0.666	0.9862
N32E	9	1.8	3.7	—	—	—	—	—	—
N34W	1*	—	—	—	—	—	—	—	—
N34W	2	1.7	2.5	3	40	0.658	0.9973	0.655	0.9975
N34W	3	1.7	2.5	4	33	0.709	0.9956	0.712	0.9954

Cable	Run	Bandpass Filter		Time Filter		Positive Peaks		Negative Peaks	
		Low (Hz)	High (Hz)	Start (s)	End (s)	Damping (Percent)	Correlation	Damping (Percent)	Correlation
N34W	4	1.2	2.8	40	65	0.723	0.9923	0.720	0.9924
N34W	4**	1.2	2.8	176	200	0.754	0.9896	0.754	0.9898
N34W	5	1.7	2.5	3	45	0.628	0.9919	0.626	0.9922
N34W	6	1.7	2.5	3	40	0.619	0.9924	0.617	0.9931
N34W	7	1.7	2.5	3	50	0.564	0.9958	0.567	0.9952
N34W	8	1.7	2.5	3	40	0.619	0.9958	0.623	0.9953
N34W	9	1.7	2.5	3	40	0.605	0.9926	0.601	0.9930
N33W	1*	—	—	—	—	—	—	—	—
N33W	2	1.7	3.0	3	40	0.576	0.9904	0.577	0.9901
N33W	3	1.7	3.0	3	40	0.564	0.9911	0.563	0.9909
N33W	4	1.7	3.0	3	40	0.606	0.9908	0.606	0.9906
N33W	5	1.8	2.9	3	35	0.615	0.9948	0.612	0.9947
N33W	6	1.8	2.9	3	40	0.584	0.9935	0.583	0.9935
N33W	7	1.8	2.9	3	35	0.611	0.9920	0.607	0.9925
N33W	8	1.8	2.9	3	35	0.607	0.9933	0.606	0.9935
N33W	9	1.8	2.9	3	35	0.587	0.9925	0.589	0.9923
N32W	1*	—	—	—	—	—	—	—	—
N32W	2	2.0	3.2	2	40	0.454	0.9499	0.449	0.9511
N32W	3	2.0	3.2	2	30	0.574	0.9565	0.570	0.9608
N32W	4	2.0	3.2	2	40	0.422	0.9760	0.424	0.9742
N32W	5	2.0	3.2	2	40	0.434	0.9690	0.429	0.9716
N32W	6***	—	—	—	—	—	—	—	—
N32W	7***	—	—	—	—	—	—	—	—
N32W	8	2.0	3.2	13	50	0.416	0.9860	0.418	0.9855
N32W	9	2.0	3.2	6	40	0.471	0.9601	0.475	0.9593
S01	1*	—	—	—	—	—	—	—	—
S01	2	2.0	3.0	22	37	0.935	0.9973	0.933	0.9972
S01	3	3.0	4.2	15	35	0.685	0.9820	0.691	0.9814
S01	4	3.0	4.2	8	30	0.685	0.9775	0.686	0.9767

Cable	Run	Bandpass Filter		Time Filter		Positive Peaks		Negative Peaks	
		Low (Hz)	High (Hz)	Start (s)	End (s)	Damping (Percent)	Correlation	Damping (Percent)	Correlation
S01	5	3.0	4.2	10	30	0.774	0.9791	0.778	0.9787
S01	6	3.1	4.2	9	28	0.666	0.9375	0.670	0.9401
S01	7	3.1	4.2	9	30	0.720	0.9813	0.721	0.9819
S01	8	3.1	4.2	10	28	0.633	0.9647	0.634	0.9663
S01	9	3.0	4.0	35	70	0.218	0.9851	0.219	0.9851
S02	1*	—	—	—	—	—	—	—	—
S02	2	3.0	4.5	—	—	—	—	—	—
S02	3	3.0	4.5	13	24	1.068	0.9878	1.066	0.9881
S02	4	3.0	4.5	9	20	0.994	0.9908	0.993	0.9900
S02	5	3.0	4.5	11	22	1.004	0.9949	1.007	0.9950
S02	6	3.0	4.5	8	20	0.886	0.9748	0.885	0.9740
S02	7	3.0	4.5	8	20	1.048	0.9624	1.019	0.9632
S02	8	3.0	4.5	29	40	0.972	0.9908	0.969	0.9904
S02	9	3.0	4.5	25	37	1.009	0.9952	1.007	0.9950
S03	1*	—	—	—	—	—	—	—	—
S03	2	—	—	—	—	—	—	—	—
S03	3	3.5	5.5	118	131	0.946	0.9979	0.952	0.9972
S03	4	—	—	—	—	—	—	—	—
S03	5	—	—	—	—	—	—	—	—
S03	6	—	—	—	—	—	—	—	—
S03	7	—	—	—	—	—	—	—	—
S03	8	—	—	—	—	—	—	—	—
S34E	1*	—	—	—	—	—	—	—	—
S34E	2	1.7	2.8	12	30	0.965	0.9966	0.962	0.9965
S34E	3	1.7	2.8	12	30	1.030	0.9820	1.024	0.9819
S34E	4	1.7	2.8	9	30	0.873	0.9941	0.876	0.9945
S34E	5	1.7	2.8	10	30	0.970	0.9982	0.967	0.9983
S34E	6	1.7	2.8	11	25	0.891	0.9891	0.892	0.9891
S34E	7	1.7	2.8	16	35	0.948	0.9970	0.947	0.9970

Cable	Run	Bandpass Filter		Time Filter		Positive Peaks		Negative Peaks	
		Low (Hz)	High (Hz)	Start (s)	End (s)	Damping (Percent)	Correlation	Damping (Percent)	Correlation
S34E	8	1.7	2.8	13	35	1.032	0.9873	1.029	0.9872
S34E	9	1.7	2.8	18	37	0.959	0.9955	0.965	0.9952
S33E	1*	—	—	—	—	—	—	—	—
S33E	2	1.7	3.5	192	210	1.220	0.9966	1.226	0.9966
S33E	3	1.7	3.5	—	—	—	—	—	—
S33E	4	1.7	3.5	—	—	—	—	—	—
S33E	5	2.0	3.5	27	50	0.867	0.9903	0.873	0.9893
S33E	6	2.0	3.5	16	35	1.094	0.9919	1.103	0.9919
S33E	7	2.0	3.5	—	—	—	—	—	—
S33E	8	2.0	3.5	—	—	—	—	—	—
S33E	9	2.0	3.5	—	—	—	—	—	—
S32E	1*	—	—	—	—	—	—	—	—
S32E	2	2.0	3.3	—	—	—	—	—	—
S32E	3	2.0	3.3	—	—	—	—	—	—
S32E	4	2.0	3.3	—	—	—	—	—	—
S32E	5	2.0	3.3	—	—	—	—	—	—
S32E	6	2.0	3.3	—	—	—	—	—	—
S32E	7	2.0	3.3	—	—	—	—	—	—
S32E	8	2.0	3.3	—	—	—	—	—	—
S32E	9^	—	—	—	—	—	—	—	—
S34W	1*	—	—	—	—	—	—	—	—
S34W	2	1.7	2.8	6	40	0.620	0.9961	0.618	0.9962
S34W	3	1.7	2.8	17	50	0.618	0.9978	0.614	0.9982
S34W	4	1.7	2.8	10	40	0.620	0.9930	0.625	0.9913
S34W	5	1.7	2.8	8	50	0.604	0.9980	0.601	0.9979
S34W	6	1.7	2.8	10	45	0.586	0.9980	0.587	0.9975
S34W	7	1.7	2.8	—	—	—	—	—	—
S34W	8	1.7	2.8	—	—	—	—	—	—
S34W	9	1.7	2.8	—	—	—	—	—	—

Cable	Run	Bandpass Filter		Time Filter		Positive Peaks		Negative Peaks	
		Low (Hz)	High (Hz)	Start (s)	End (s)	Damping (Percent)	Correlation	Damping (Percent)	Correlation
S33W	1*	—	—	—	—	—	—	—	—
S33W	2	1.8	2.8	6	30	0.753	0.9827	0.760	0.9825
S33W	3	1.8	2.8	8	30	0.734	0.9779	0.725	0.9784
S33W	4	1.8	2.8	8	35	0.718	0.9919	0.722	0.9912
S33W	5	1.8	2.8	3	30	0.651	0.9850	0.652	0.9851
S33W	6	1.8	2.8	6	30	0.777	0.9878	0.783	0.9872
S33W	7	1.8	2.8	10	35	0.698	0.9868	0.702	0.9867
S33W	8	1.8	2.8	8	30	0.773	0.9833	0.764	0.9836
S33W	9	1.8	2.8	9	35	0.692	0.9828	0.695	0.9829
S32W	1*	—	—	—	—	—	—	—	—
S32W	2	2.0	3.4	14	25	1.432	0.9780	1.449	0.9801
S32W	3	2.0	3.4	10	24	1.403	0.9945	1.398	0.9944
S32W	4	2.0	3.4	11	21	1.405	0.9911	1.396	0.9912
S32W	5	2.0	3.4	10	23	1.495	0.9956	1.514	0.9939
S32W	6	2.0	3.4	10	24	1.458	0.9754	1.443	0.9737
S32W	7	2.0	3.4	9	20	1.472	0.9979	1.466	0.9979
S32W	8	2.0	3.4	10	22	1.534	0.9928	1.527	0.9932
S32W	9	2.0	3.4	10	22	1.525	0.9914	1.546	0.9901

*Baseline run.

**Second dataset from same run.

***Corrupt data file.

^Missing file.

—No data available.

Table 25. Phase 3, box 2, first-mode damping data.

Cable	Run	Bandpass Filter		Time Filter		Positive Peaks		Negative Peaks	
		Low (Hz)	High (Hz)	Start (s)	End (s)	Damping (Percent)	Correlation	Damping (Percent)	Correlation
N01	1*	—	—	—	—	—	—	—	—
N01	2	2.5	3.3	28	50	0.693	0.9846	0.695	0.9853
N01	3	2.5	3.4	50	65	0.806	0.9929	0.800	0.9935
N01	4	2.5	3.4	62	80	0.670	0.9961	0.669	0.9960
N01	5	2.5	3.3	32	55	0.716	0.9960	0.715	0.9959
N01	6	2.5	3.3	—	—	—	—	—	—
N01	7	3.4	4.5	—	—	—	—	—	—
N01	8	2.5	3.3	—	—	—	—	—	—
N01	9	2.5	3.3	19	42	0.653	0.9947	0.653	0.9947
N02	1*	—	—	—	—	—	—	—	—
N02	2	2	3.7	54	70	0.659	0.9694	0.652	0.9685
N02	3	2	3.9	30	46	0.691	0.9757	0.731	0.9771
N02	4	2	5	45	54	0.916	0.9926	0.922	0.9931
N02	5	2	3.8	41	50	0.859	0.9531	0.799	0.9047
N02	6	3.7	5.5	52	62	0.924	0.9585	0.944	0.9605
N02	7	3.7	5.5	63	72	1.056	0.9900	1.044	0.9893
N02	8	3.7	5.5	23	35	1.089	0.9798	1.087	0.9801
N02	9	2.3	3.7	—	—	—	—	—	—
N03	1*	—	—	—	—	—	—	—	—
N03	2	—	—	—	—	—	—	—	—
N03	3	—	—	—	—	—	—	—	—
N03	4	—	—	—	—	—	—	—	—
N03	5	—	—	—	—	—	—	—	—
N03	6	—	—	—	—	—	—	—	—
N03	7	4	6.2	—	—	—	—	—	—
N03	8	4	6.2	—	—	—	—	—	—
N03	9	4	6.2	—	—	—	—	—	—
N34E	1*	—	—	—	—	—	—	—	—

Cable	Run	Bandpass Filter		Time Filter		Positive Peaks		Negative Peaks	
		Low (Hz)	High (Hz)	Start (s)	End (s)	Damping (Percent)	Correlation	Damping (Percent)	Correlation
N34E	2	1.5	2.9	21	35	1.837	0.9926	1.822	0.9930
N34E	3	1.5	2.9	15	25	2.238	0.9947	2.239	0.9952
N34E	4	1.5	2.9	19	30	2.172	0.9962	2.169	0.9964
N34E	5	1.5	2.9	14	26	1.992	0.9968	1.975	0.9966
N34E	6	1.5	2.9	16	28	1.789	0.9929	1.753	0.9948
N34E	7	1.5	2.9	18	30	1.666	0.9978	1.676	0.9976
N34E	8	1.5	2.9	10	25	1.327	0.9953	1.328	0.9953
N34E	9	1.5	2.9	14	26	1.981	0.9950	1.977	0.9951
N33E	1*	—	—	—	—	—	—	—	—
N33E	2	1.8	3.5	61	71	1.883	0.9844	1.878	0.9822
N33E	3	1.8	4	37	50	1.644	0.9795	1.624	0.9802
N33E	4	1.8	3.8	10	20	1.656	0.9807	1.611	0.9764
N33E	5	1.8	3.8	—	—	—	—	—	—
N33E	6	1.8	3.8	—	—	—	—	—	—
N33E	7	1.6	3.8	10	25	1.453	0.9800	1.433	0.9783
N33E	8	1.6	3.8	13	23	1.670	0.9938	1.680	0.9935
N33E	9	1.6	3.5	13	24	1.049	0.9730	1.056	0.9721
N32E	1*	—	—	—	—	—	—	—	—
N32E	2	2	4	39	65	0.687	0.9963	0.687	0.9961
N32E	3	1.9	4	20	45	0.738	0.9902	0.738	0.9904
N32E	4	1.9	4	—	—	—	—	—	—
N32E	5	1.9	3.9	24	45	0.726	0.9941	0.732	0.9938
N32E	6	1.9	3.9	24	50	0.691	0.9938	0.689	0.9937
N32E	7	1.9	3.9	18	40	0.662	0.9800	0.665	0.9798
N32E	8	1.9	3.9	17	40	0.697	0.9814	0.692	0.9810
N32E	9	1.8	3.7	—	—	—	—	—	—
N34W	1*	—	—	—	—	—	—	—	—
N34W	2	1.7	2.6	3	40	0.657	0.9984	0.658	0.9983
N34W	3	1.7	2.6	3	30	0.700	0.9964	0.694	0.9969

Cable	Run	Bandpass Filter		Time Filter		Positive Peaks		Negative Peaks	
		Low (Hz)	High (Hz)	Start (s)	End (s)	Damping (Percent)	Correlation	Damping (Percent)	Correlation
N34W	4	1.7	2.6	40	65	0.727	0.9929	0.726	0.9929
N34W	4**	1.7	2.6	177	200	0.752	0.9916	0.750	0.9914
N34W	5	1.7	2.6	3	40	0.652	0.9926	0.652	0.9932
N34W	6	1.7	2.6	3	40	0.614	0.9942	0.609	0.9946
N34W	7	1.7	2.6	3	40	0.576	0.9935	0.579	0.9931
N34W	8	1.7	2.6	0	40	0.628	0.9960	0.625	0.9955
N34W	9	1.7	2.6	3	40	0.605	0.9937	0.602	0.9943
N33W	1*	—	—	—	—	—	—	—	—
N33W	2	1.8	3	3	30	0.610	0.9935	0.610	0.9938
N33W	3	1.8	2.8	3	40	0.566	0.9937	0.565	0.9935
N33W	4	1.8	3	3	35	0.636	0.9956	0.637	0.9955
N33W	5	1.8	3	3	40	0.591	0.9954	0.590	0.9953
N33W	6	1.8	3	2	40	0.588	0.9958	0.589	0.9955
N33W	7	1.8	3	3	30	0.600	0.9949	0.601	0.9949
N33W	8	1.8	3	3	30	0.630	0.9967	0.629	0.9968
N33W	9	1.8	3	3	40	0.559	0.9921	0.561	0.9923
N32W	1*	—	—	—	—	—	—	—	—
N32W	2	1.8	3.6	0	40	0.463	0.9615	0.461	0.9626
N32W	3	1.8	3.6	3	35	0.438	0.9757	0.441	0.9748
N32W	4	1.8	3.6	3	50	0.381	0.9851	0.379	0.9858
N32W	5	2	3.4	0	50	0.401	0.9733	0.401	0.9733
N32W	6***	—	—	—	—	—	—	—	—
N32W	7***	—	—	—	—	—	—	—	—
N32W	8	2	3.4	10	50	0.460	0.9745	0.458	0.9748
N32W	9	2	3.4	5	45	0.447	0.9623	0.442	0.9614
S01	1*	—	—	—	—	—	—	—	—
S01	2	2	3.3	20	37	0.924	0.9940	0.931	0.9947
S01	3	3	4.2	14	35	0.680	0.9810	0.681	0.9803
S01	4	3	4.2	7	30	0.688	0.9782	0.684	0.9769

Cable	Run	Bandpass Filter		Time Filter		Positive Peaks		Negative Peaks	
		Low (Hz)	High (Hz)	Start (s)	End (s)	Damping (Percent)	Correlation	Damping (Percent)	Correlation
S01	5	3	4.2	8	26	0.686	0.9740	0.692	0.9742
S01	6	3	4.2	8	30	0.667	0.9539	0.668	0.9541
S01	7	3	4.2	8	30	0.731	0.9830	0.729	0.9834
S01	8	3	4.2	9	26	0.653	0.9571	0.653	0.9572
S01	9	3	4.2	35	70	0.206	0.9516	0.207	0.9520
S02	1*	—	—	—	—	—	—	—	—
S02	2	2	5	—	—	—	—	—	—
S02	3	3	4.6	13	26	0.987	0.9880	0.984	0.9884
S02	4	3	5	8	22	0.941	0.9917	0.943	0.9915
S02	5	3	4.5	11	26	0.956	0.9924	0.962	0.9924
S02	6	3	5	8	18	0.993	0.9804	0.988	0.9801
S02	7	3	5	7	19	1.162	0.9603	1.173	0.9621
S02	8	3	4.5	29	41	0.936	0.9915	0.940	0.9918
S02	9	3	5	24	40	1.115	0.9931	1.111	0.9932
S03	1*	—	—	—	—	—	—	—	—
S03	2	—	—	—	—	—	—	—	—
S03	3	3.9	5.5	118	130	0.961	0.9967	0.955	0.9965
S03	4	—	—	—	—	—	—	—	—
S03	5	—	—	—	—	—	—	—	—
S03	6	—	—	—	—	—	—	—	—
S03	7	—	—	—	—	—	—	—	—
S03	8	—	—	—	—	—	—	—	—
S34E	1*	—	—	—	—	—	—	—	—
S34E	2	1.9	3	11	32	0.960	0.9975	0.962	0.9976
S34E	3	1.9	3	11	30	0.997	0.9815	1.011	0.9817
S34E	4	1.9	3	9	30	0.883	0.9945	0.884	0.9945
S34E	5	1.8	3	9	30	0.976	0.9979	0.972	0.9980
S34E	6	1.8	3	10	25	0.883	0.9900	0.889	0.9896
S34E	7	1.8	3	15	40	1.042	0.9932	1.037	0.9933

Cable	Run	Bandpass Filter		Time Filter		Positive Peaks		Negative Peaks	
		Low (Hz)	High (Hz)	Start (s)	End (s)	Damping (Percent)	Correlation	Damping (Percent)	Correlation
S34E	8	1.8	3	12	32	0.933	0.9968	0.932	0.9966
S34E	9	1.8	3	17	37	0.972	0.9958	0.978	0.9956
S33E	1*	—	—	—	—	—	—	—	—
S33E	2	1.9	3.3	192	210	1.207	0.9969	1.212	0.9968
S33E	3	1.9	4	—	—	—	—	—	—
S33E	4	1.9	4	—	—	—	—	—	—
S33E	5	1.9	3.3	26	50	0.865	0.9909	0.870	0.9908
S33E	6	1.9	3.3	15	30	1.026	0.9918	1.035	0.9920
S33E	7	1.9	3.3	—	—	—	—	—	—
S33E	8	1.9	3.3	—	—	—	—	—	—
S33E	9	1.9	3.3	—	—	—	—	—	—
S32E	1*	—	—	—	—	—	—	—	—
S32E	2	1.9	3.8	—	—	—	—	—	—
S32E	3	1.9	3.8	—	—	—	—	—	—
S32E	4	1.9	4	—	—	—	—	—	—
S32E	5	1.9	3.8	—	—	—	—	—	—
S32E	6	1.9	4	—	—	—	—	—	—
S32E	7	1.9	4	—	—	—	—	—	—
S32E	8	1.9	4	—	—	—	—	—	—
S32E	9 [^]	—	—	—	—	—	—	—	—
S34W	1*	—	—	—	—	—	—	—	—
S34W	2	1.9	3	7	40	0.611	0.9959	0.612	0.9958
S34W	3	1.9	3	15	50	0.647	0.9955	0.645	0.9956
S34W	4	1.8	2.7	10	40	0.630	0.9934	0.633	0.9932
S34W	5	1.8	2.7	6	50	0.637	0.9954	0.638	0.9955
S34W	6	1.8	2.7	9	40	0.622	0.9943	0.620	0.9945
S34W	7	1.5	3	—	—	—	—	—	—
S34W	8	1.5	3	—	—	—	—	—	—
S34W	9	1.5	3	—	—	—	—	—	—

Cable	Run	Bandpass Filter		Time Filter		Positive Peaks		Negative Peaks	
		Low (Hz)	High (Hz)	Start (s)	End (s)	Damping (Percent)	Correlation	Damping (Percent)	Correlation
S33W	1*	—	—	—	—	—	—	—	—
S33W	2	1.8	3.5	5	30	0.752	0.9860	0.759	0.9863
S33W	3	1.8	3.5	9	35	0.664	0.9831	0.666	0.9829
S33W	4	1.8	3.5	6	40	0.744	0.9942	0.745	0.9942
S33W	5	1.8	3.1	2	30	0.656	0.9872	0.658	0.9861
S33W	6	1.8	3.2	6	30	0.771	0.9914	0.766	0.9917
S33W	7	1.8	3.2	8	40	0.702	0.9908	0.701	0.9906
S33W	8	1.8	3.2	6	40	0.784	0.9933	0.780	0.9928
S33W	9	1.8	3.2	8	40	0.651	0.9835	0.645	0.9838
S32W	1*	—	—	—	—	—	—	—	—
S32W	2	1.8	3.8	13	22	1.461	0.9829	1.510	0.9775
S32W	3	1.8	4.2	10	25	1.390	0.9944	1.392	0.9945
S32W	4	1.8	4.2	10	23	1.581	0.9875	1.593	0.9872
S32W	5	1.8	4	10	25	1.649	0.9886	1.637	0.9886
S32W	6	1.8	4	10	25	1.422	0.9615	1.390	0.9671
S32W	7	1.8	4	8	23	1.595	0.9945	1.587	0.9942
S32W	8	1.8	4	10	25	1.578	0.9935	1.576	0.9934
S32W	9	1.8	4	10	25	1.602	0.9920	1.599	0.9921

*Baseline run.

**Second dataset from same run.

***Corrupt data file.

^Missing file.

—No data available.

Table 26. Phase 3, box 1, second-mode damping data.

Cable	Run	Bandpass Filter		Time Filter		Positive Peaks		Negative Peaks	
		Low (Hz)	High (Hz)	Start (s)	End (s)	Damping (Percent)	Correlation	Damping (Percent)	Correlation
N01	1*	—	—	—	—	—	—	—	—
N01	2	7	8	—	—	—	—	—	—
N01	3	5.7	7	—	—	—	—	—	—
N01	4	—	—	—	—	—	—	—	—
N01	5	—	—	—	—	—	—	—	—
N01	6	8	9	—	—	—	—	—	—
N01	7	—	—	—	—	—	—	—	—
N01	8	—	—	—	—	—	—	—	—
N01	9	—	—	—	—	—	—	—	—
N02	1*	—	—	—	—	—	—	—	—
N02	2	—	—	—	—	—	—	—	—
N02	3	—	—	—	—	—	—	—	—
N02	4	—	—	—	—	—	—	—	—
N02	5	—	—	—	—	—	—	—	—
N02	6	—	—	—	—	—	—	—	—
N02	7	—	—	—	—	—	—	—	—
N02	8	—	—	—	—	—	—	—	—
N02	9	—	—	—	—	—	—	—	—
N03	1*	—	—	—	—	—	—	—	—
N03	2	—	—	—	—	—	—	—	—
N03	3	—	—	—	—	—	—	—	—
N03	4	—	—	—	—	—	—	—	—
N03	5	—	—	—	—	—	—	—	—
N03	6	—	—	—	—	—	—	—	—
N03	7	—	—	—	—	—	—	—	—
N03	8	—	—	—	—	—	—	—	—
N03	9	—	—	—	—	—	—	—	—
N34E	1*	—	—	—	—	—	—	—	—

Cable	Run	Bandpass Filter		Time Filter		Positive Peaks		Negative Peaks	
		Low (Hz)	High (Hz)	Start (s)	End (s)	Damping (Percent)	Correlation	Damping (Percent)	Correlation
N34E	2	3.7	5	—	—	—	—	—	—
N34E	3	3.7	5	—	—	—	—	—	—
N34E	4	3.7	5	—	—	—	—	—	—
N34E	5	3.7	5	—	—	—	—	—	—
N34E	6	3.7	5	—	—	—	—	—	—
N34E	7	3.7	5.2	—	—	—	—	—	—
N34E	8	3.7	5	—	—	—	—	—	—
N34E	9	3.5	5	—	—	—	—	—	—
N33E	1*	—	—	—	—	—	—	—	—
N33E	2	4.2	6	—	—	—	—	—	—
N33E	3	4	6	—	—	—	—	—	—
N33E	4	4	6	—	—	—	—	—	—
N33E	5	4	6	—	—	—	—	—	—
N33E	6	4	6	—	—	—	—	—	—
N33E	7	4	6	—	—	—	—	—	—
N33E	8	4	6	—	—	—	—	—	—
N33E	9	4	6	—	—	—	—	—	—
N32E	1*	—	—	—	—	—	—	—	—
N32E	2	5	6.3	—	—	—	—	—	—
N32E	3	4.8	6.2	—	—	—	—	—	—
N32E	4	4.8	6.3	—	—	—	—	—	—
N32E	5	4.7	6.3	—	—	—	—	—	—
N32E	6	4.8	6.3	—	—	—	—	—	—
N32E	7	4.8	6.3	—	—	—	—	—	—
N32E	8	4.8	6.2	—	—	—	—	—	—
N32E	9	4.8	6.2	—	—	—	—	—	—
N34W	1*	—	—	—	—	—	—	—	—
N34W	2	4.1	4.6	5	30	0.526	0.9901	0.524	0.9904
N34W	3	3.9	4.6	4	25	0.516	0.9964	0.515	0.9967

Cable	Run	Bandpass Filter		Time Filter		Positive Peaks		Negative Peaks	
		Low (Hz)	High (Hz)	Start (s)	End (s)	Damping (Percent)	Correlation	Damping (Percent)	Correlation
N34W	4	3.9	4.9	41	65	0.518	0.9958	0.518	0.9958
N34W	4**	3.9	4.6	178	205	0.605	0.9978	0.606	0.9978
N34W	5	3.9	4.6	4	25	0.574	0.9982	0.573	0.9983
N34W	6	3.9	4.6	4	30	0.557	0.9964	0.557	0.9963
N34W	7	3.9	4.6	4	25	0.493	0.9955	0.492	0.9955
N34W	8	3.9	4.6	4	28	0.512	0.9985	0.513	0.9985
N34W	9	3.9	4.6	4	26	0.537	0.9968	0.536	0.9969
N33W	1*	—	—	—	—	—	—	—	—
N33W	2	4.5	5.4	—	—	—	—	—	—
N33W	3	4.4	5.5	—	—	—	—	—	—
N33W	4	4.4	5.5	—	—	—	—	—	—
N33W	5	4.4	5.5	—	—	—	—	—	—
N33W	6	4.1	5.5	—	—	—	—	—	—
N33W	7	4.4	5.5	—	—	—	—	—	—
N33W	8	4.2	5.5	—	—	—	—	—	—
N33W	9	4.4	5.5	—	—	—	—	—	—
N32W	1*	—	—	—	—	—	—	—	—
N32W	2	4.4	5.6	—	—	—	—	—	—
N32W	3	4.8	5.9	—	—	—	—	—	—
N32W	4	4.8	5.7	—	—	—	—	—	—
N32W	5	4.5	5.8	—	—	—	—	—	—
N32W	6***	—	—	—	—	—	—	—	—
N32W	7***	—	—	—	—	—	—	—	—
N32W	8	4.5	6.2	13	22	0.963	0.9952	0.953	0.9947
N32W	9	4.5	6.2	9	18	0.903	0.9915	0.909	0.9919
S01	1*	—	—	—	—	—	—	—	—
S01	2	5.9	7.8	—	—	—	—	—	—
S01	3	6.4	7.5	15	22	0.895	0.9970	0.886	0.9964
S01	4	6.4	7.5	—	—	—	—	—	—

Cable	Run	Bandpass Filter		Time Filter		Positive Peaks		Negative Peaks	
		Low (Hz)	High (Hz)	Start (s)	End (s)	Damping (Percent)	Correlation	Damping (Percent)	Correlation
S01	5	6.5	7.7	—	—	—	—	—	—
S01	6	5.9	7.7	—	—	—	—	—	—
S01	7	5.9	7.7	—	—	—	—	—	—
S01	8	6.5	8	—	—	—	—	—	—
S01	9	6.5	7.5	—	—	—	—	—	—
S02	1*	—	—	—	—	—	—	—	—
S02	2	6.2	8.6	—	—	—	—	—	—
S02	3	7.1	8.2	15	21	1.109	0.9924	1.100	0.9918
S02	4	7.1	8.2	—	—	—	—	—	—
S02	5	7.1	8.2	12	18	1.261	0.9885	1.250	0.9886
S02	6	6.6	8.2	—	—	—	—	—	—
S02	7	6.6	9.5	—	—	—	—	—	—
S02	8	6.6	9.5	—	—	—	—	—	—
S02	9	6.6	9.5	—	—	—	—	—	—
S03	1*	—	—	—	—	—	—	—	—
S03	2	7	10.5	—	—	—	—	—	—
S03	3	8	10.3	—	—	—	—	—	—
S03	4	—	—	—	—	—	—	—	—
S03	5	8	10.3	—	—	—	—	—	—
S03	6	—	—	—	—	—	—	—	—
S03	7	—	—	—	—	—	—	—	—
S03	8	8	10.3	—	—	—	—	—	—
S34E	1*	—	—	—	—	—	—	—	—
S34E	2	4	5.3	—	—	—	—	—	—
S34E	3	4	5.1	—	—	—	—	—	—
S34E	4	4	5.1	—	—	—	—	—	—
S34E	5	4	5.1	—	—	—	—	—	—
S34E	6	4	5.1	—	—	—	—	—	—
S34E	7	4	5.1	—	—	—	—	—	—

Cable	Run	Bandpass Filter		Time Filter		Positive Peaks		Negative Peaks	
		Low (Hz)	High (Hz)	Start (s)	End (s)	Damping (Percent)	Correlation	Damping (Percent)	Correlation
S34E	8	4	5.1	—	—	—	—	—	—
S34E	9	4	5.1	—	—	—	—	—	—
S33E	1*	—	—	—	—	—	—	—	—
S33E	2	4.5	5.9	—	—	—	—	—	—
S33E	3	4.8	6	—	—	—	—	—	—
S33E	4	4.8	6	—	—	—	—	—	—
S33E	5	4.5	5.9	—	—	—	—	—	—
S33E	6	4.5	6	—	—	—	—	—	—
S33E	7	4.5	6	—	—	—	—	—	—
S33E	8	4.5	6	—	—	—	—	—	—
S33E	9	4.8	6	—	—	—	—	—	—
S32E	1*	—	—	—	—	—	—	—	—
S32E	2	4.8	6.6	—	—	—	—	—	—
S32E	3	5	6.5	—	—	—	—	—	—
S32E	4	5	6.5	—	—	—	—	—	—
S32E	5	5	6.5	—	—	—	—	—	—
S32E	6	5	6.5	—	—	—	—	—	—
S32E	7	5	6.5	—	—	—	—	—	—
S32E	8	5	7	—	—	—	—	—	—
S32E	9^	—	—	—	—	—	—	—	—
S34W	1*	—	—	—	—	—	—	—	—
S34W	2	3.9	4.7	7	18	0.888	0.9985	0.885	0.9985
S34W	3	3.7	4.8	17	30	0.982	0.9966	0.978	0.9964
S34W	4	3.7	4.8	11	25	0.815	0.9914	0.820	0.9911
S34W	5	3.7	4.9	8	20	0.915	0.9983	0.908	0.9984
S34W	6	3.7	4.9	10	25	0.853	0.9966	0.855	0.9967
S34W	7	3.7	4.9	—	—	—	—	—	—
S34W	8	3.7	4.9	—	—	—	—	—	—
S34W	9	3.7	4.9	—	—	—	—	—	—

Cable	Run	Bandpass Filter		Time Filter		Positive Peaks		Negative Peaks	
		Low (Hz)	High (Hz)	Start (s)	End (s)	Damping (Percent)	Correlation	Damping (Percent)	Correlation
S33W	1*	—	—	—	—	—	—	—	—
S33W	2	4.3	5.5	—	—	—	—	—	—
S33W	3	4.3	5.5	—	—	—	—	—	—
S33W	4	4.3	5.5	—	—	—	—	—	—
S33W	5	4.3	5.5	—	—	—	—	—	—
S33W	6	4.3	5.5	—	—	—	—	—	—
S33W	7	4.3	5.5	—	—	—	—	—	—
S33W	8	4.3	5.5	—	—	—	—	—	—
S33W	9	4.3	5.5	—	—	—	—	—	—
S32W	1*	—	—	—	—	—	—	—	—
S32W	2	5	6.5	—	—	—	—	—	—
S32W	3	5	6.5	—	—	—	—	—	—
S32W	4	4.9	6.3	—	—	—	—	—	—
S32W	5	5	6.4	—	—	—	—	—	—
S32W	6	5	6.4	—	—	—	—	—	—
S32W	7	5	6.4	—	—	—	—	—	—
S32W	8	5	6.7	—	—	—	—	—	—
S32W	9	5	6.5	—	—	—	—	—	—

*Baseline run.

**Second dataset from same run.

***Corrupt data file.

^Missing file.

—No data available.

Table 27. Phase 3, box 2, second-mode damping data.

Cable	Run	Bandpass Filter		Time Filter		Positive Peaks		Negative Peaks	
		Low (Hz)	High (Hz)	Start (s)	End (s)	Damping (Percent)	Correlation	Damping (Percent)	Correlation
N01	1*	—	—	—	—	—	—	—	—
N01	2	—	—	—	—	—	—	—	—
N01	3	—	—	—	—	—	—	—	—
N01	4	—	—	—	—	—	—	—	—
N01	5	—	—	—	—	—	—	—	—
N01	6	—	—	—	—	—	—	—	—
N01	7	—	—	—	—	—	—	—	—
N01	8	—	—	—	—	—	—	—	—
N01	9	—	—	—	—	—	—	—	—
N02	1*	—	—	—	—	—	—	—	—
N02	2	—	—	—	—	—	—	—	—
N02	3	—	—	—	—	—	—	—	—
N02	4	—	—	—	—	—	—	—	—
N02	5	—	—	—	—	—	—	—	—
N02	6	—	—	—	—	—	—	—	—
N02	7	—	—	—	—	—	—	—	—
N02	8	—	—	—	—	—	—	—	—
N02	9	—	—	—	—	—	—	—	—
N03	1*	—	—	—	—	—	—	—	—
N03	2	—	—	—	—	—	—	—	—
N03	3	—	—	—	—	—	—	—	—
N03	4	—	—	—	—	—	—	—	—
N03	5	—	—	—	—	—	—	—	—
N03	6	—	—	—	—	—	—	—	—
N03	7	—	—	—	—	—	—	—	—
N03	8	—	—	—	—	—	—	—	—
N03	9	—	—	—	—	—	—	—	—
N34E	1*	—	—	—	—	—	—	—	—

Cable	Run	Bandpass Filter		Time Filter		Positive Peaks		Negative Peaks	
		Low (Hz)	High (Hz)	Start (s)	End (s)	Damping (Percent)	Correlation	Damping (Percent)	Correlation
N34E	2	3.8	5	—	—	—	—	—	—
N34E	3	3.5	5	—	—	—	—	—	—
N34E	4	3.5	5	—	—	—	—	—	—
N34E	5	3.5	5	—	—	—	—	—	—
N34E	6	3.5	5	—	—	—	—	—	—
N34E	7	3.5	5	—	—	—	—	—	—
N34E	8	3.8	5	—	—	—	—	—	—
N34E	9	3.8	5	—	—	—	—	—	—
N33E	1*	—	—	—	—	—	—	—	—
N33E	2	4	5.2	—	—	—	—	—	—
N33E	3	4	5.5	—	—	—	—	—	—
N33E	4	4	5.5	—	—	—	—	—	—
N33E	5	4	6	—	—	—	—	—	—
N33E	6	4	6	—	—	—	—	—	—
N33E	7	4	5.7	—	—	—	—	—	—
N33E	8	4	5.7	—	—	—	—	—	—
N33E	9	4	5.7	—	—	—	—	—	—
N32E	1*	—	—	—	—	—	—	—	—
N32E	2	5	6	—	—	—	—	—	—
N32E	3	4.7	6	—	—	—	—	—	—
N32E	4	4.7	6	—	—	—	—	—	—
N32E	5	4.7	6.2	—	—	—	—	—	—
N32E	6	4.7	6.2	—	—	—	—	—	—
N32E	7	5	6	—	—	—	—	—	—
N32E	8	5	6	—	—	—	—	—	—
N32E	9	4	6.6	—	—	—	—	—	—
N34W	1*	—	—	—	—	—	—	—	—
N34W	2	3.9	4.7	—	—	—	—	—	—
N34W	3	4	4.6	—	—	—	—	—	—

Cable	Run	Bandpass Filter		Time Filter		Positive Peaks		Negative Peaks	
		Low (Hz)	High (Hz)	Start (s)	End (s)	Damping (Percent)	Correlation	Damping (Percent)	Correlation
N34W	4	4	4.6	—	—	—	—	—	—
N34W	4**	4	4.6	—	—	—	—	—	—
N34W	5	4	4.6	—	—	—	—	—	—
N34W	6	4	4.6	—	—	—	—	—	—
N34W	7	4	4.6	—	—	—	—	—	—
N34W	8	4	4.6	—	—	—	—	—	—
N34W	9	4	4.6	—	—	—	—	—	—
N33W	1*	—	—	—	—	—	—	—	—
N33W	2	4.4	4.9	—	—	—	—	—	—
N33W	3	4.4	4.9	—	—	—	—	—	—
N33W	4	4.4	4.9	—	—	—	—	—	—
N33W	5	4.4	4.9	—	—	—	—	—	—
N33W	6	4.4	4.9	—	—	—	—	—	—
N33W	7	4.4	4.9	—	—	—	—	—	—
N33W	8	4.4	4.9	—	—	—	—	—	—
N33W	9	4.4	4.9	—	—	—	—	—	—
N32W	1*	—	—	—	—	—	—	—	—
N32W	2	4.5	5.8	—	—	—	—	—	—
N32W	3	4.5	6	—	—	—	—	—	—
N32W	4	4.8	5.7	—	—	—	—	—	—
N32W	5	4.8	5.7	—	—	—	—	—	—
N32W	6***	—	—	—	—	—	—	—	—
N32W	7***	—	—	—	—	—	—	—	—
N32W	8	4.8	5.9	—	—	—	—	—	—
N32W	9	4.7	6	—	—	—	—	—	—
S01	1*	—	—	—	—	—	—	—	—
S01	2	—	—	—	—	—	—	—	—
S01	3	6.5	7.5	—	—	—	—	—	—
S01	4	6.5	7.5	—	—	—	—	—	—

Cable	Run	Bandpass Filter		Time Filter		Positive Peaks		Negative Peaks	
		Low (Hz)	High (Hz)	Start (s)	End (s)	Damping (Percent)	Correlation	Damping (Percent)	Correlation
S01	5	6.5	7.5	—	—	—	—	—	—
S01	6	6.5	7.5	—	—	—	—	—	—
S01	7	6.5	7.5	—	—	—	—	—	—
S01	8	6.5	7.5	—	—	—	—	—	—
S01	9	6.5	7.5	—	—	—	—	—	—
S02	1*	—	—	—	—	—	—	—	—
S02	2	—	—	—	—	—	—	—	—
S02	3	—	—	—	—	—	—	—	—
S02	4	—	—	—	—	—	—	—	—
S02	5	—	—	—	—	—	—	—	—
S02	6	7	8.8	—	—	—	—	—	—
S02	7	7.8	9	—	—	—	—	—	—
S02	8	—	—	—	—	—	—	—	—
S02	9	—	—	—	—	—	—	—	—
S03	1*	—	—	—	—	—	—	—	—
S03	2	—	—	—	—	—	—	—	—
S03	3	—	—	—	—	—	—	—	—
S03	4	—	—	—	—	—	—	—	—
S03	5	8.2	10	—	—	—	—	—	—
S03	6	—	—	—	—	—	—	—	—
S03	7	—	—	—	—	—	—	—	—
S03	8	—	—	—	—	—	—	—	—
S34E	1*	—	—	—	—	—	—	—	—
S34E	2	3.9	5.1	12	22	0.863	0.9881	0.868	0.9887
S34E	3	3.9	5.1	14	27	0.878	0.9945	0.881	0.9947
S34E	4	4.1	5.1	10	18	0.883	0.9808	0.897	0.9802
S34E	5	4	5.1	10	23	0.829	0.9944	0.831	0.9942
S34E	6	4	5.1	10	23	0.760	0.9820	0.768	0.9828
S34E	7	4	5.1	16	30	0.733	0.9875	0.738	0.9881

Cable	Run	Bandpass Filter		Time Filter		Positive Peaks		Negative Peaks	
		Low (Hz)	High (Hz)	Start (s)	End (s)	Damping (Percent)	Correlation	Damping (Percent)	Correlation
S34E	8	4	5.1	13	22	0.772	0.9887	0.764	0.9890
S34E	9	4	5.1	18	30	0.764	0.9813	0.767	0.9813
S33E	1*	—	—	—	—	—	—	—	—
S33E	2	4.5	5.5	—	—	—	—	—	—
S33E	3	4.5	6	—	—	—	—	—	—
S33E	4	5	6.5	—	—	—	—	—	—
S33E	5	4.7	5.8	—	—	—	—	—	—
S33E	6	4.5	5.7	—	—	—	—	—	—
S33E	7	4.5	6	—	—	—	—	—	—
S33E	8	4.5	6	—	—	—	—	—	—
S33E	9	4.5	6	—	—	—	—	—	—
S32E	1*	—	—	—	—	—	—	—	—
S32E	2	4.8	6.2	—	—	—	—	—	—
S32E	3	5	6.3	—	—	—	—	—	—
S32E	4	5	6.6	—	—	—	—	—	—
S32E	5	5.2	6.4	—	—	—	—	—	—
S32E	6	5	6.4	—	—	—	—	—	—
S32E	7	5	7	—	—	—	—	—	—
S32E	8	5	6.8	—	—	—	—	—	—
S32E	9^	—	—	—	—	—	—	—	—
S34W	1*	—	—	—	—	—	—	—	—
S34W	2	4	5.1	—	—	—	—	—	—
S34W	3	3.8	5.9	—	—	—	—	—	—
S34W	4	4	5.1	—	—	—	—	—	—
S34W	5	3.8	5.1	—	—	—	—	—	—
S34W	6	3.8	4.8	—	—	—	—	—	—
S34W	7	3.2	5.5	9	22	0.861	0.9837	0.872	0.9805
S34W	8	3.2	5.5	—	—	—	—	—	—
S34W	9	3.3	5	—	—	—	—	—	—

Cable	Run	Bandpass Filter		Time Filter		Positive Peaks		Negative Peaks	
		Low (Hz)	High (Hz)	Start (s)	End (s)	Damping (Percent)	Correlation	Damping (Percent)	Correlation
S33W	1*	—	—	—	—	—	—	—	—
S33W	2	4.4	5.3	—	—	—	—	—	—
S33W	3	4.1	5.3	—	—	—	—	—	—
S33W	4	4.2	5.3	—	—	—	—	—	—
S33W	5	4.2	5.3	—	—	—	—	—	—
S33W	6	4.2	5.3	—	—	—	—	—	—
S33W	7	4.4	5.5	—	—	—	—	—	—
S33W	8	4	5.3	—	—	—	—	—	—
S33W	9	4	5.3	—	—	—	—	—	—
S32W	1*	—	—	—	—	—	—	—	—
S32W	2	5	6	—	—	—	—	—	—
S32W	3	4.5	6.5	—	—	—	—	—	—
S32W	4	5	6	—	—	—	—	—	—
S32W	5	5	6.3	—	—	—	—	—	—
S32W	6	4.4	6.3	—	—	—	—	—	—
S32W	7	4.8	6.3	—	—	—	—	—	—
S32W	8	5	6.3	—	—	—	—	—	—
S32W	9	5	6.3	—	—	—	—	—	—

*Baseline run.

**Second dataset from same run.

***Corrupt data file.

^Missing file.

—No data available.

Table 28. Phase 3 summary of average damping values.

Cable	Mode	Average Damping Value (Percent)	Max Damping Value^a (Percent)	Min Damping Value^a (Percent)	Correlation	Average Length of Time Sample (s)
N01	1	0.759	0.833	0.685	0.9914	18.5
N02	1	0.788	0.868	0.708	0.9774	13.2
N03	1	0.796	0.904	0.687	0.9250	16.0
N34E	1	1.923	2.057	1.788	0.9941	12.2
N33E	1	1.605	1.726	1.483	0.9830	11.3
N32E	1	0.691	0.705	0.677	0.9896	24.4
N34W	1	0.655	0.679	0.631	0.9940	34.2
N33W	1	0.596	0.606	0.586	0.9935	33.6
N32W	1	0.447	0.472	0.422	0.9692	38.5
S01	1	0.660	0.745	0.574	0.9736	21.6
S02	1	1.005	1.040	0.970	0.9853	12.3
S03	1	0.954	1.000	0.907	0.9973	12.5
S34E	1	0.957	0.981	0.934	0.9929	19.6
S33E	1	1.047	1.176	0.917	0.9931	19.5
S32E	1	—	—	—	—	—
S34W	1	0.619	0.629	0.609	0.9957	34.7
S33W	1	0.720	0.741	0.699	0.9867	27.0
S32W	1	1.500	1.536	1.464	0.9882	13.1
N01	2	—	—	—	—	—
N02	2	—	—	—	—	—
N03	2	—	—	—	—	—
N34E	2	—	—	—	—	—
N33E	2	—	—	—	—	—
N32E	2	—	—	—	—	—
N34W	2	0.537	0.559	0.516	0.9962	23.4
N33W	2	—	—	—	—	—
N32W	2	0.933	1.120	0.746	0.9934	9.0
S01	2	0.895	0.895	0.895	0.9970	7.0

Cable	Mode	Average Damping Value (Percent)	Max Damping Value^a (Percent)	Min Damping Value^a (Percent)	Correlation	Average Length of Time Sample (s)
S02	2	1.185	1.667	0.703	0.9904	6.0
S03	2	—	—	—	—	—
S34E	2	0.810	0.850	0.770	0.9872	11.5
S33E	2	—	—	—	—	—
S32E	2	—	—	—	—	—
S34W	2	0.886	0.933	0.838	0.9942	13.0
S33W	2	—	—	—	—	—
S32W	2	—	—	—	—	—

^aMaximum and minimum values are for the 90-percent confidence interval on the mean.

—No data available.

APPENDIX D. CABLE PROPERTIES

Table 29. General properties of tested cables.

Cable	Strand Count	Unit Weight (lb/ft)	Diameter (inch)	Length (ft)
S01	73	73	9.84	350.7
S02	73	71	9.84	335.1
S03	72	70	9.84	319.6
S32E	43	43	8.86	388.9
S33E	44	44	8.86	388.2
S34E	45	45	8.86	407.7
S32W	25	26	7.09	368.8
S33W	26	27	7.09	388.1
S34W	27	28	7.09	407.6
N01	70	65	9.84	340.5
N02	69	64	9.84	325.2
N03	68	63	9.84	310.0
N32E	41	40	8.86	382.8
N33E	41	40	8.86	402.8
N34E	41	40	8.86	422.9
N32W	23	24	7.09	382.6
N33W	24	25	7.09	402.6
N34W	24	25	7.09	422.8

1 lb/ft = 14.6 N/m; 1 inch = 25.4 mm; 1 ft = 0.305 m.

REFERENCES

1. Post-Tensioning Institute. (2001). *Recommendations for Stay Cable Design, Testing and Installation*, Fourth Edition, Phoenix, AZ.
2. Kumarasena, S. Jones, N.P., Irwin, P., and Taylor, P. (2007). *Wind-Induced Vibration of Stay Cables*, Report No. FHWA-HRT-05-083, Federal Highway Administration, Washington, DC.
3. Park, S. and Bosch, H.R. (2014). *Mitigation of Wind-Induced Vibration of Stay Cables: Numerical Simulations and Evaluations*, Report No. FHWA-HRT-14-049, Federal Highway Administration, Washington, DC.
4. Larose, G.L. and D'Auteuil, A. (2014). *Wind Tunnel Investigations of an Inclined Stay Cable with a Helical Fillet*, Report No. FHWA-HRT-14-070, Federal Highway Administration, Washington, DC.
5. Bosch, H.R. and Pagenkopf, J.R. (2014). *Dynamic Properties of Stay Cables on the Penobscot Narrows Bridge*, Report No. FHWA-HRT-14-067, Federal Highway Administration, Washington, DC.
6. Bosch, H.R. and Pagenkopf, J.R. (2017). *Dynamic Properties of Stay Cables on the Bill Emerson*, Report No. FHWA-HRT-17-037, Federal Highway Administration, Washington, DC.
7. Hikami, Y. and Shiraishi, N. (1988). "Rain/Wind-Induced Vibrations in Cables in Cable-Stayed Bridges," *Journal of Wind Engineering and Industrial Aerodynamics*, 29, 409–418.
8. Matsumoto, M., Shiraishi, N., and Shirato, H. (1992). "Rain/Wind-Induced Vibration of Cables of Cable-Stayed Bridges," *Journal of Wind Engineering and Industrial Aerodynamics*, 33, 63–72.
9. Flamand, O. (1994). "Rain/Wind-Induced Vibration of Cables," *Proceedings of the International Conference on Cable-Stayed and Suspension Bridges (AFPC)*, 2, 523–531, Deauville, France.
10. Verwiebe, C. and Ruscheweyh, H. (1997). "Recent Research Concerning Excitation Mechanisms of Rain/Wind-Induced Vibrations," *Proceedings of the Second European African Conference on Wind Engineering*, Genoa, Italy, 1,783–1,789.
11. Bosch, H.R. (2000). "Rain/Wind Induced Vibration of Bridge Cables in the United States," *Proceedings of Thirty-Second U.S.A.-Japan Conference on Wind and Seismic Effects*, Gaithersburg, MD.
12. Graff, K.F. (1975). *Wave Motion in Elastic Solids*, Oxford University Press, Oxford, United Kingdom.

13. Craig Jr., R. (1981). *Structural Dynamics*, John Wiley & Sons, New York, NY.
14. Google Maps®. (2017). *Location of the Leonard P. Zakim Bunker Hill Bridge site*. Generated by James Pagenkopf via Google Maps® online. Obtained from: <https://www.google.com/maps/@42.3546183,-71.0672744,13z?hl=en>. Accessed December 21, 2017.
15. Massachusetts Department of Transportation. (1997). *General Plan and Elevation*. (Drawing No. S-007). [Technical Drawing]. Retrieved from MassDOT August 24, 1999.
16. Massachusetts Department of Transportation. (1997). *Main Span and Back Span Typical Cross Section*. (Drawing No. S-010). [Technical Drawing]. Retrieved from MassDOT August 24, 1999.
17. MathWorks. (2006). *MATLAB Computer Software*, Version 2013b, MathWorks, Natick, MA.
18. Milton, J., Arnold, J. (2003). *Introduction to Probability and Statistics*, McGraw Hill, New York, NY.
19. Simiu, E., Scanlan, R.H. (1996). *Wind Effects on Structures*, 3rd Ed., John Wiley & Sons, New York, NY.
20. Irwin, P.A. (1997). “Wind Vibrations of Cables on Cable-Stayed Bridges,” *Proceedings of Structures Congress XV, 1*, 383–387, American Society of Civil Engineers, Reston, VA.
21. Computers and Structures, Inc. (2014). *SAP2000 Computer Software*, Version 16.1, Computers and Structures, Inc., Walnut Creek, CA.
22. Abdel-Ghaffar, A.M., Khalifa, M.A. (1991). “Importance of Cable Vibration in Dynamics of Cable-Stayed Bridges,” *Journal of Engineering Mechanics*, 117, 2,571–2,589.
23. Caracoglia, L. and Jones, N.P. (2005). “In-Plane Dynamic Behavior of Cable Networks Part 2: Prototype Prediction and Validation,” *Journal of Sound and Vibration*, 279, 993–1,014.

