

# Bridge Information Modeling (BrIM) Using Open Parametric Objects

Publication No. HIF-16-010

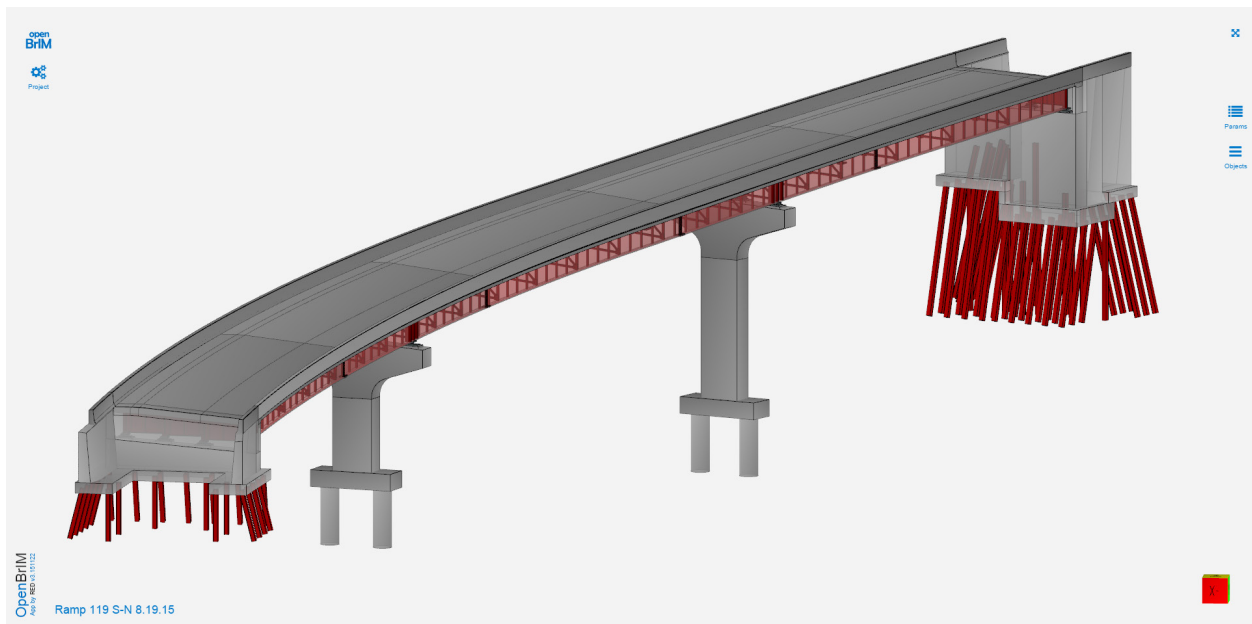

U.S. Department of Transportation  
**Federal Highway Administration**



1. Report No. FHWA-HIF-16-010	2. Government Accession No. XXX	3. Recipient's Catalog No. XXX	
4. Title and Subtitle Bridge Information Modeling (BrIM) Using Open Parametric Objects		5. Report Date December 2015	
		6. Performing Organization Code XXX	
7. Author(s) Bartholomew, Michael Blasen, Benjamin Koc, Ali		8. Performing Organization Report No. XXX	
9. Performing Organization Name and Address CH2M 1100 NE Circle Blvd. Suite 300 Corvallis, OR 97330		10. Work Unit No. XXX	
		11. Contract or Grant No. DTFH61-11-H-00027	
12. Sponsoring Agency Name and Address Federal Highway Administration Office of Infrastructure— Bridges and Structures 1200 New Jersey Ave., SE Washington, DC 20590		13. Type of Report and Period Covered XXX	
		14. Sponsoring Agency Code HIBS-10	
15. Supplementary Notes Work funded by Cooperative Agreement "Advancing Steel and Concrete Bridge Technology to Improve Infrastructure Performance" between FHWA and Lehigh University.			
16. Abstract This project was undertaken to investigate alternative Bridge Information Modeling standards. The process developed is called OpenBrIM. OpenBrIM is an alternative method for exchanging bridge information modeling data between different application platforms, organizations, and users. It is a community driven, free, open, on-cloud information modeling system designed for the bridge industry. With OpenBrIM, there's one central data repository from which all participants operate. Participants are allowed to access information from and to contribute information into the repository. For this project, approximately 30 standard bridge component objects were developed. The OpenBrIM concept uses a standard XML data format to describe dimensions and other data parameters for bridge components. Bridge component library objects are defined parametrically, allowing repeated use for similar components by varying the geometric and/or physical property data. Common data can be defined globally within a project and automatically update all affected objects. In the future, new standards will be developed by the bridge community – the actual users of the information with the most knowledge about various bridge components.			
17. Key Words Bridge Information Modeling, BrIM, BIM, 3-D modeling		18. Distribution Statement No restrictions. This document is available to the public online and through the National Technical Information Service, Springfield, VA 22161.	
19. Security Classif. (of this report) Unclassified	20. Security Classif. (of this page) Unclassified	21. No of Pages 296	22. Price \$XXX.XX

# SI\* (MODERN METRIC) CONVERSION FACTORS

## APPROXIMATE CONVERSIONS TO SI UNITS

Symbol	When You Know	Multiply By	To Find	Symbol
<b>LENGTH</b>				
in	inches	25.4	millimeters	mm
ft	feet	0.305	meters	m
yd	yards	0.914	meters	m
mi	miles	1.61	kilometers	km
<b>AREA</b>				
in <sup>2</sup>	square inches	645.2	square millimeters	mm <sup>2</sup>
ft <sup>2</sup>	square feet	0.093	square meters	m <sup>2</sup>
yd <sup>2</sup>	square yard	0.836	square meters	m <sup>2</sup>
ac	acres	0.405	hectares	ha
mi <sup>2</sup>	square miles	2.59	square kilometers	km <sup>2</sup>
<b>VOLUME</b>				
fl oz	fluid ounces	29.57	milliliters	mL
gal	gallons	3.785	liters	L
ft <sup>3</sup>	cubic feet	0.028	cubic meters	m <sup>3</sup>
yd <sup>3</sup>	cubic yards	0.765	cubic meters	m <sup>3</sup>
NOTE: volumes greater than 1000 L shall be shown in m <sup>3</sup>				
<b>MASS</b>				
oz	ounces	28.35	grams	g
lb	pounds	0.454	kilograms	kg
T	short tons (2000 lb)	0.907	megagrams (or "metric ton")	Mg (or "t")
<b>TEMPERATURE (exact degrees)</b>				
°F	Fahrenheit	5 (F-32)/9 or (F-32)/1.8	Celsius	°C
<b>ILLUMINATION</b>				
fc	foot-candles	10.76	lux	lx
fl	foot-Lamberts	3.426	candela/m <sup>2</sup>	cd/m <sup>2</sup>
<b>FORCE and PRESSURE or STRESS</b>				
lbf	poundforce	4.45	newtons	N
lbf/in <sup>2</sup>	poundforce per square inch	6.89	kilopascals	kPa
<b>APPROXIMATE CONVERSIONS FROM SI UNITS</b>				
Symbol	When You Know	Multiply By	To Find	Symbol
<b>LENGTH</b>				
mm	millimeters	0.039	inches	in
m	meters	3.28	feet	ft
m	meters	1.09	yards	yd
km	kilometers	0.621	miles	mi
<b>AREA</b>				
mm <sup>2</sup>	square millimeters	0.0016	square inches	in <sup>2</sup>
m <sup>2</sup>	square meters	10.764	square feet	ft <sup>2</sup>
m <sup>2</sup>	square meters	1.195	square yards	yd <sup>2</sup>
ha	hectares	2.47	acres	ac
km <sup>2</sup>	square kilometers	0.386	square miles	mi <sup>2</sup>
<b>VOLUME</b>				
mL	milliliters	0.034	fluid ounces	fl oz
L	liters	0.264	gallons	gal
m <sup>3</sup>	cubic meters	35.314	cubic feet	ft <sup>3</sup>
m <sup>3</sup>	cubic meters	1.307	cubic yards	yd <sup>3</sup>
<b>MASS</b>				
g	grams	0.035	ounces	oz
kg	kilograms	2.202	pounds	lb
Mg (or "t")	megagrams (or "metric ton")	1.103	short tons (2000 lb)	T
<b>TEMPERATURE (exact degrees)</b>				
°C	Celsius	1.8C+32	Fahrenheit	°F
<b>ILLUMINATION</b>				
lx	lux	0.0929	foot-candles	fc
cd/m <sup>2</sup>	candela/m <sup>2</sup>	0.2919	foot-Lamberts	fl
<b>FORCE and PRESSURE or STRESS</b>				
N	newtons	0.225	poundforce	lbf
kPa	kilopascals	0.145	poundforce per square inch	lbf/in <sup>2</sup>

\*SI is the symbol for the International System of Units. Appropriate rounding should be made to comply with Section 4 of ASTM E380.  
(Revised March 2003)

**Notice**

This document is disseminated under the sponsorship of the U.S. Department of Transportation in the interest of information exchange. The U.S. Government assumes no liability for the use of the information contained in this document.

The U.S. Government does not endorse products or manufacturers. Trademarks or manufacturers' names appear in this report only because they are considered essential to the objective of the document.



# Contents

Section	Page
<b>Contents</b> .....	<b>vii</b>
<b>1 Executive Summary</b> .....	<b>1-1</b>
<b>2 Introduction</b> .....	<b>2-1</b>
2.1 Project Goals .....	2-1
2.1.1 Previous Work Products .....	2-1
2.1.2 Task 12b Scope of Work .....	2-2
2.1.3 Current Industry BrIM/BIM Capabilities .....	2-4
<b>3 OpenBrIM Concept</b> .....	<b>3-1</b>
3.1 Overview .....	3-1
3.2 Bridge Component Standards .....	3-2
3.3 Data Structure/Format .....	3-2
3.4 Centralized Data Repository .....	3-5
3.5 Community Driven .....	3-6
<b>4 OpenBrIM Applications</b> .....	<b>4-1</b>
4.1 Purpose .....	4-1
4.1.1 OpenBrIM Library .....	4-2
4.1.2 OpenBrIM App .....	4-5
<b>5 Bridge Component Modeling</b> .....	<b>5-1</b>
5.1 Basic Geometric Constructs .....	5-1
5.2 Parametric Modeling .....	5-7
5.3 Units .....	5-10
5.4 Alignment .....	5-11
5.4.1 Horizontal Segment .....	5-12
5.4.2 Vertical Segment .....	5-14
5.4.3 Cross Slope Segment .....	5-16
5.4.4 Alignment Functions .....	5-18
5.5 Developed Component Library Objects .....	5-20
5.5.1 Abutments .....	5-22
5.5.2 Piers .....	5-28
5.5.3 Bearings .....	5-31
5.5.4 Concrete Girders .....	5-31
5.5.5 Steel Girders .....	5-33
5.5.6 Decks .....	5-44
5.5.7 Bridge Railings .....	5-46
5.5.8 Miscellaneous .....	5-46
<b>6 Bridge Modeling</b> .....	<b>6-1</b>
6.1 Building BrIM Models .....	6-1
6.1.1 Example Object Creation .....	6-3
6.2 Positioning Component Objects .....	6-4
6.2.1 Example Object Positioning .....	6-4
6.3 Grouping and Hierarchy of Components .....	6-6
6.3.1 Example Object Grouping .....	6-8

6.4	Locating and Orienting Components to Alignments .....	6-9
6.4.1	Example Deck Section .....	6-11
6.4.2	Example Girder Section .....	6-12
6.4.3	Example Cross Frame .....	6-15
<b>7</b>	<b>Gaps .....</b>	<b>7-1</b>
<b>8</b>	<b>Industry Outreach .....</b>	<b>8-1</b>
<b>9</b>	<b>Conclusions .....</b>	<b>9-1</b>
9.1	Advantages of OpenBrIM .....	9-1
9.2	Next Steps .....	9-2
9.3	Concluding Remarks .....	9-2

**Appendices**

- A Library Object Definitions
- B Example Bridge Model

**Table**

1	Component Library Objects .....	5-21
---	---------------------------------	------

**Figures**

1	OpenBrIM Concept .....	3-1
2	Rectangular Footing Template View in OpenBrIM Library .....	3-3
3	Pier2Footing Shown in a Project .....	3-4
4	Pier2Footing Selected Inside Project .....	3-5
5	OpenBrIM Opening Screen .....	4-1
6	Initial Registration Screen .....	4-2
7	OpenBrIM Library App Layout .....	4-3
8	Library Object Description .....	4-3
9	Library Object Parameters .....	4-4
10	XML Code .....	4-4
11	Hollow Box Beam Section .....	5-1
12	ParamML Code for Hollow Section Line Object .....	5-2
13	Line Object with Hollow Section .....	5-3
14	Surface Object for Bolted Gusset Plate .....	5-4
15	ParamML Code for Bolted Gusset Plate Surface Object .....	5-5
16	Tapered Column Elevation Views .....	5-6
17	ParamML Code for Tapered Column Volume Object .....	5-6
18	Volume Object for Tapered Column .....	5-7
19	Precast Girder Standard Drawing .....	5-8
20	Precast Girder Schedule .....	5-9
21	Oregon Bulb-T Girder Object .....	5-9
22	Example Alignment .....	5-11
23	Ramp 119 S-N Horizontal Alignment .....	5-12
24	Ramp 119 S-N Horizontal Curve Data .....	5-12
25	Ramp 119 S-N Horizontal Alignment in OpenBrIM .....	5-13



26	Ramp 119 S-N Vertical Profile .....	5-14
27	Ramp 119 S-N Vertical Curve Data .....	5-14
28	Ramp 119 S-N Vertical Profile in OpenBrlM .....	5-15
29	Ramp 119 S-N Typical Cross Section .....	5-16
30	Ramp 119 S-N Cross Slope Variation in OpenBrlM .....	5-18
31	Ramp 119 S-N Abutment 1 .....	5-22
32	H-Pile Batter Orientation, Phi Angle .....	5-23
33	Pile Parameters .....	5-23
34	Abutment U-Shaped Footing Parameters .....	5-24
35	Abutment U-Shaped Footing Graphical Representation of Parameters .....	5-24
36	Abutment Backwall Library Object .....	5-26
37	Abutment Backwall in the Project .....	5-26
38	Ramp 119 S-N Hammerhead Pier .....	5-29
39	Hammerhead Pier Cap with Crown .....	5-30
40	Pot Bearing .....	5-31
41	Steel I-Girder .....	5-33
42	Steel I-Girder Section Data .....	5-33
43	Top Flange Range Variable Data .....	5-34
44	Shear Stiffener Location Data .....	5-34
45	Shear Stiffener Object .....	5-37
46	Shear Stiffener Input Data .....	5-37
47	Girder Bolted Field Splice .....	5-39
48	Web Field Splice Bolt Pattern Input .....	5-40
49	Flange Field Splice Bolt Pattern Input .....	5-40
50	Cross Frame Geometry from Library .....	5-42
51	Cross Frame Geometry in Project .....	5-42
52	Plate Diaphragm .....	5-43
53	Deck Cross Section .....	5-44
54	Deck Input Parameters .....	5-45
55	3D Representation of Deck .....	5-45
56	3-D Representation of Deck from Below .....	5-45
57	Reinforcing Stirrup Bar Bend .....	5-47
58	Full Model of Ramp 119 S-N .....	6-1
59	OpenBrlM App Interface .....	6-1
60	OpenBrlM App - Create Project .....	6-2
61	OpenBrlM App Add Object .....	6-2
62	New Object Documentation Dialog Box .....	6-2
63	New Object Parameters Dialog Box .....	6-3
64	Model View of Added Object .....	6-3
65	Edit Object Dialog Box .....	6-4
66	Model View of Multiple Drilled Shafts .....	6-5
67	Model View Object Explorer .....	6-6
68	Object Explorer Window .....	6-7
69	Model View with Object Explorer Open .....	6-8

CONTENTS

70	Model View of Drilled Shafts Rotated 90° .....	6-9
71	Use of Align Parameters .....	6-10
72	Straight Beam Behavior .....	6-10
73	Ramp 119 S-N Deck/Girder Key Parameter .....	6-12
74	Ramp 119 S-N Girder Framing Plan .....	6-13
75	Ramp 119 S-N Girder 1 Elevation .....	6-13
76	Ramp 119 S-N Girder 1 Field Section 1 .....	6-14
77	Ramp 119 S-N Girder/Deck Interface .....	6-15
78	Ramp 119 S-N Cross Frame .....	6-15
79	Ramp 119 S-N Cross Frame Racking .....	6-17
80	Ramp 119 S-N Cross Frame Variations .....	6-17

# Section 1 – Executive Summary

Bridge Information Modeling (BrIM) has been slower to develop in the transportation infrastructure industry than Building Information Modeling (BIM) has in the commercial sectors. This project was undertaken to explore new methods for engineering bridges that take advantage of the rapid advancements in computer information technology. As the business world progresses, there is more emphasis on reducing paper documents, and replacing them with electronic formats.

Another goal of the project was to investigate ways to standardize information as it is passed between the participants in bridge projects from initial project concept through to end of the useful service life. There are many players involved and many transactions that take place during this life cycle. The end goal is achieving interoperability between all of these entities with the least amount of data recreation and ultimately advancing the bridge engineering practice.

Traditional BIM/BrIM modeling relies on the use of vendor's proprietary software to create models in a data format native to the application. For sharing data with other application platforms, organizations, and users, a translation of the data via some type of agreed-upon "standard" is required. A standard file system called Industry Foundation Classes (IFC) is used extensively in the building industry for exchanging digital information, but that system hasn't been developed fully for bridges.

An alternative method for exchanging bridge information modeling data between different application platforms, organizations, and users, is developed and documented as part of this work. Collectively it is called "openBrIM." It is a community driven, non-proprietary, open, on-cloud, parametric information modeling system designed for the bridge industry. With OpenBrIM, ideally there would not be any file exchange. Rather, there's one central data repository from which all participants operate. Participants are allowed to access information from and to contribute information into the repository. The OpenBrIM community manages libraries, enforces security, assures integrity, and promotes collaboration.

For this project, we have developed approximately 30 standard bridge component objects and incorporated them into openBrIM. OpenBrIM definitions use a standard XML data format to describe dimensions and other data parameters for bridge engineering information. Bridge component library objects are defined parametrically, allowing repeated use for similar components by varying the geometric and/or physical property data. Common data can be defined globally within a project and automatically update all affected objects. In the future, new objects, materials, relationships, etc. will be developed by the bridge community – the actual users of the information with the most knowledge about various bridge components.

OpenBrIM offers complete independence from any local software installation with free web-based modeling and visualization tools. The program gains enormous flexibility by providing information through the internationally accepted XML standard, requiring only minimal hardware resources with a web browser connected to the internet. For example, a conference room computer could quickly access a model during a meeting, or an inspector could verify a bridge component in the field with their tablet or smartphone.

The ability to review, manipulate, and build models in OpenBrIM without having any knowledge of programming or ability to read computer code will significantly facilitate adoption of this as standard practice by the broader bridge design and construction community.

OpenBrIM is a more holistic, all-encompassing, adaptable approach that merits attention by the bridge engineering community.



# Section 2 – Introduction

The research work described herein was performed under the FHWA Cooperative Agreement project DTFH61-11-H-00027 led by Lehigh University, “Advancing Steel and Concrete Bridge Technology to Improve Infrastructure Performance”. This specific assignment was performed by CH2M as Task 12b, “Technical Review and Industry Outreach for Bridge Information Modeling (BrIM) Standards”.

## 2.1 Project Goals

The overall project goals established at the beginning of the project are as follows:

Vision – Exploit the full potential of computer technology by transforming the current bridge practice into a full digital delivery practice from project development to end use (cradle to grave).

Objectives – To further develop and promote credible, robust, software neutral, digital BrIM standards, to automate data transfer among different software applications within the bridge community, and promote the concept of interoperability of data between many platforms, including project concept visualization, design, detailing, construction, in-service inspection and maintenance, and structural and service life performance monitoring.

The key goals driving this work are:

- Transforming bridge practice from paper delivery to digital delivery
- Developing digital BrIM standards
- Providing interoperability between many platforms and life-cycle stages
- Maintaining software neutrality

### 2.1.1 Previous Work Products

Task 12b is a follow-on to Task 12a, “Bridge Data File Protocols for Interoperability and Life Cycle Management” of the FHWA Cooperative Agreement DTFH61-11-H-0027, “Advancing Steel and Concrete Bridge Technology to Improve Infrastructure Performance”, which was previously completed by the State University of New York (SUNY) at Buffalo, and produced the following three volume report.

- Volume 1 – Implementation Roadmap for Bridge Information Modeling (BrIM) Data Exchange Protocols
- Volume 2 – Information Delivery Manual Elements for Highway Bridge Interoperable Data Protocols
- Volume 3 – Model View Definition Elements for Highway Bridge Interoperable Data Protocols

This previous work focused on developing a new digital data protocol for automating the exchange of bridge information between the activities involved in the bridge life-cycle, from design and construction through to operations and asset management. This protocol was coined as “openBrIM” to promote the concept of software neutrality. The key deliverables produced in the project reports were:

- Process map
- Data Exchange Models (EMs)
- Data Dictionaries (DDs)
- Model View Definitions (MVDs)

- Information Delivery Manuals (IDMs)

In developing the work, it was necessary to develop 3D models of bridges and bridge components to demonstrate the applicability of the data protocol. A viewing/modeling program, OpenBrIM developed by Red Equation Corporation, was used for demonstration purposes. OpenBrIM versions 1 and 2 were both used during Task 12a work.

## 2.1.2 Task 12b Scope of Work

### 2.1.2.1 Original

One of the main objectives of the current scope of work was to have a team of practicing engineers perform a critical review and vetting of the work principally performed by a team from academia. Work was to include the review of the following three Case Study models referenced in Volume 3 of the SUNY Buffalo report:

- Quincy Avenue over I-25 and LRT – 3-span prestressed concrete bulb-T girder bridge in Denver, CO
- Glenridge Road over Alplaus Kill – Single span prestressed concrete adjacent box beam bridge in Glenville, NY
- I-290 Ramp B over I-290 Ramp D and I-90 – A 2-span steel plate I-girder bridge in NY

Contained within these models were the following bridge component definitions:

#### Roadway Geometry Components (3)

- Horizontal Alignment
- Vertical Profile
- Superelevation

#### Cross Section Templates (5)

- Circular
- Rectangular
- Steel I
- 610x1220(NY) Box Beam
- BT72 Prestressed Concrete I Girder

#### Component Object Templates (23)

- Concrete Deck
- Haunch
- Steel I Girder
- Left & Right Stiffener
- CrossFrame K Closed
- CrossFrame X Closed
- CrossFrame V Closed
- Bottom Lateral Brace

- Shear Stud
- Strands
- Bearing
- Pedestal
- Hammer Head Pier
- Multi-column Pier
- Pile
- Abutment U
- Integral Pile Abutment
- Longitudinal Rebar
- Transverse Rebar
- Web Connecting Plate (splice)
- Flange Connecting Plate (splice)
- Bolt

The intent of the review was to determine whether the bridge components were defined correctly, used terminology common to the bridge community, and could be used to develop a robust set of standards for use in BrIM models.

The second major work item was to develop documentation for standard bridge component templates. The documentation of a typical component template would be comprised of:

- A one page graphic representation of the component, with all variable dimensions defined. The graphic would include a plan view, elevation view, section view, and/or 3-D isometric view, as necessary to define the object. The base reference point for the object will be identified.
- An .xml file with the translation coding of the object. Variable names will match those on the graphic.
- A definition of how the object is used in the data schema.

The last major work item was to develop and deliver an industry outreach program with the goal of promoting the concept of BrIM and exchange information with the bridge engineering practice through webinars and workshops.

#### 2.1.2.2 Modified

As work commenced, some new developments took place that would impact the original scope of work. It was determined that the example bridge models were not available electronically, many of the components were not defined with variable parameters but with constant values, and the bridge models were not broken down into individual objects that could be readily turned into standards. Red Equation Corporation issued version 3 of the OpenBrIM application that had been used by SUNY Buffalo as the viewing/modeling demonstration program. Versions 1 and 2 were both local installations on user's computers. Version 3 is "cloud" based and has significantly more features than its predecessors, including an additional library app that is used to develop individual bridge component standards. The file format used for versions 1 and 2 was XML. Version 3 introduced ParamML, a variation of XML with a modified syntax for defining objects. While versions 1 and 2 were based on parametric modeling, version 3 added onto that concept by introducing how component standards can be developed and

assembled in a collaborative manner to create a bridge model. It was determined that more and better standards could be developed using Version 3. This resulted in less checking of the bridge models created by SUNY Buffalo, and more development of individual standardized library component objects.

The documentation of the standard library objects and the industry outreach program were still performed as originally planned.

### 2.1.3 Current Industry BrIM/BIM Capabilities

While Building Information Modeling (BIM) is a relatively mature business both internationally and in the US, BrIM is in the very early stages of development. According to the 2012 McGraw-Hill Construction SmartMarket Report, “The Business Value of BIM in North America”, BIM usage by North American companies was at 71%. A 2014 McGraw-Hill Construction SmartMarket Report, “The Business Value of BIM for Construction in Major Global Markets” shows only 14% BIM usage in the US on infrastructure projects (defined as roads, bridges, tunnels, dams, and water/wastewater). Based on this demographic, it appears that BrIM usage is lagging behind BIM usage.

Two of the key differences between BIM and BrIM are:

- Geometric definition for buildings is developed in a rectangular grid system, whereas bridges are defined with horizontal curved or straight alignments (stations and offsets), vertical grades and curve profiles (elevations), and varying cross-section (superelevation) definitions.
- The number of disciplines and construction trades involved in building structures is significantly higher than for bridges.

There are several software vendors who have developed BrIM based interfaces.

- Autodesk Revit, BIM 360
- ArchiBUS
- ArchiCAD (Hungary, 120,000 users, IFC)
- Bentley
- CodeBook (UK, database add-in )
- Data Design System AS (Norway, has IFC viewer)
- GRAITEC Advance BIM
- IDEA Architectural (full IFC compatibility)
- Tekla Structures and BIMsight (Finland, IFC compliant)
- VisualARQ (Spain, IFC)

A separate FHWA sponsored project, “Bridge Information Modeling Standardization”, is being performed in parallel with this project. The work is being undertaken by the National Institute of Building Sciences (NIBS) and will conclude with the following four volumes of documentation:

- Introduction
- Volume A – Information Exchanges
- Volume B – Schemas
- Volume C – Components

The goal of the NIBS project is to investigate the extension of existing BIM standards to bridges. The BIM standards use the Industry Foundation Class (IFC) protocol that has been developed over the past 20



years. The basic concept behind the NIBS project is that software vendors develop their programs to read and write standard translation files in the IFC format facilitating transfer of data to and from their application. This approach is quite different from the OpenBIM approach discussed in Section 2 of this document. It is quite possible that the bridge engineering industry may have need of both: a well-defined standard exchange format such as IFC and a fully flexible approach such as openBIM.



# Section 3 – OpenBrIM Concept

## 3.1 Overview

Traditional BIM/BrIM modeling relies on the use of vendor’s proprietary software to create models in a data format native to the application. For sharing data with other application platforms, organizations, and users, a translation of the data is required. In the building industry, this translation is generally done using the IFC standard previously mentioned in Section 2.1.3. Therefore the application’s native data format must be translated into the IFC format by creating a separate file. The file becomes the medium for sharing the data with others. Each time data is shared between different entities, a file is created to complete the transaction. While this is not the only way the system can work, it is the predominant way that it is currently being employed.

OpenBrIM is an alternative method for exchanging bridge information modeling data between different application platforms, organizations, and users. It is a community driven, free, open, on-cloud information modeling system designed for the bridge industry. With OpenBrIM, there is no file exchange. There’s one central data repository from which all participants operate (see Figure 1). Participants are allowed to access information from and to contribute information into the repository. OpenBrIM manages data, enforces security, assures integrity, and promotes collaboration.

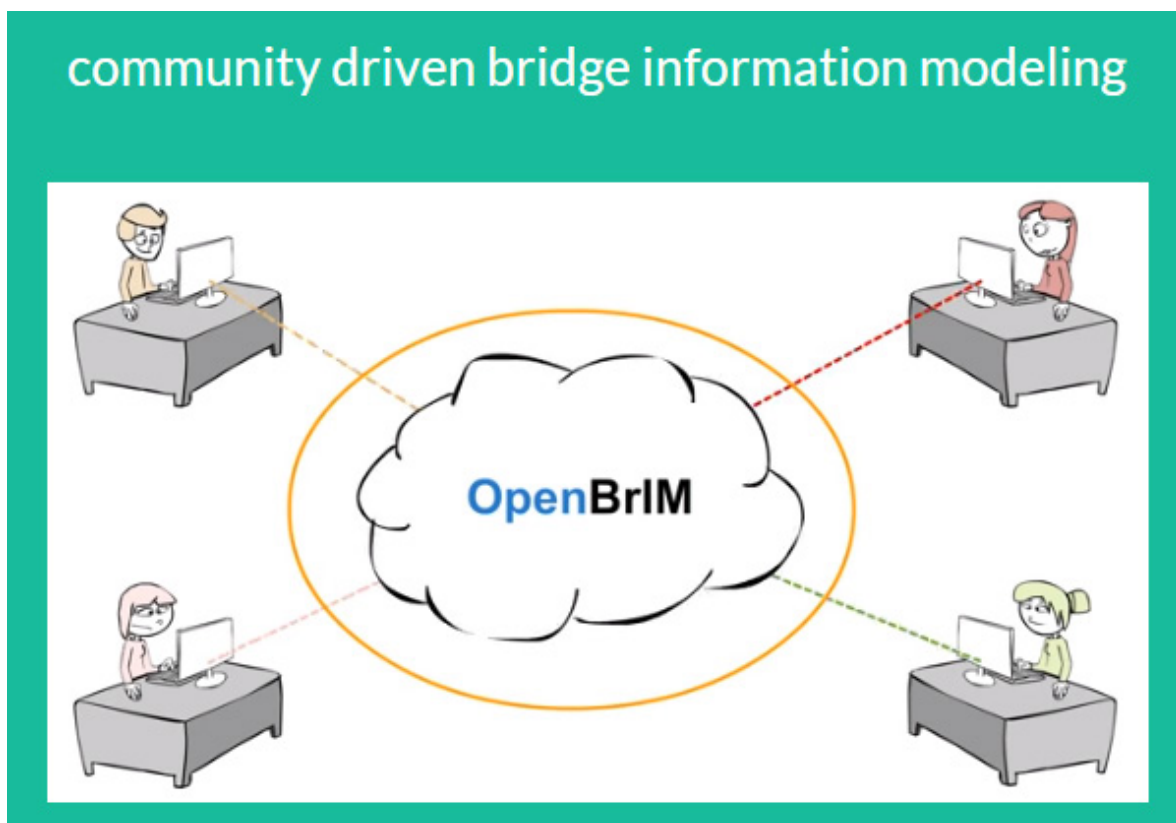

Figure 1 - OpenBrIM Concept

An informational video describing the process can be found on the OpenBrIM web page:

<https://www.openbrim.org/www/brim/>

It is also accessible through the following link:

<https://youtu.be/B6tXSv3BrSE>

## 3.2 Bridge Component Standards

Bridge structures can be envisioned as a collection of individual components such as the deck, traffic barriers, girders and cross-frames, bearings, piers and abutments. Components like piers and abutments are comprised of smaller components like piles, footings, columns, walls, caps, and steel reinforcing. All of these individual components can be defined with a relatively small number of parameters. Any component or object can be developed into a standard bridge component by identifying the minimum data parameters necessary to completely define it. A simple example is a rectangular concrete footing, where three variables – width, length, and thickness – can be used to define the outline shape. All similar rectangular footings for a bridge can use the same geometric definition, by defining separate width, length, and thickness variables for each individual footing. All that is needed is to locate their position in the overall structure by defining a reference point on the component, and its station, offset, and elevation along the bridge alignment. Other non-geometric data can also be associated with the component, such as material type or date constructed. All of these parameters form the standard data required to define the component. A complete bridge model is developed by combining all of the individual standard components into an assembly.

It is anticipated that there will need to be hundreds of individual bridge component objects developed to properly account for the complexity of bridge models. The OpenBrIM Library application provides a home where these objects can be developed, organized and hosted in an open and collaborative environment.

## 3.3 Data Structure/Format

OpenBrIM uses XML (eXtensible Markup Language) as the document format for OpenBrIM models. XML is the de-facto standard for digital document representation and exchange format across all disciplines and industries in the world today. OpenBrIM uses a subset of XML called Parametric Markup Language (ParamML). A thorough description of ParamML is given in [the ParamML author's guide](#). A detailed XSD data schema is available on the OpenBrIM website, at the following link:

<https://openbrim.appspot.com/schema.xsd?for=openbrim&v=3&format=xsd&version=1.1>.

Essentially, every line of data in a template file has either an object or a parameter tag. All objects contain parameters, and thus they generally contain a starting and ending tag. The syntax used for an object is:

```
<O>
...
</O>
```

Objects are further defined by attributes contained within the starting tag line. All objects require a mandatory **T**ype (T=) attribute, and optional **N**ame (N=), position/translation (**X**=, **Y**=, **Z**=), orientation/rotation (**R**X=, **R**Y=, **R**Z=), and rotation origin (**A**X=, **A**Y=, **A**Z=) attributes. If not explicitly stated, the position/translation attributes default to a value of 0.

Parameters are typically defined on a single line, therefore a shorter form of syntax can be used as follows:

```
<P ... />
```

Parameters are also defined with attributes. All parameters require a mandatory **N**ame (N=) attribute, and optional **T**ype (T=), **V**alue (V=), **D**escription (D=), **R**ole (Role=), **C**ategory (Category=), **U**nit **T**ype (UT=), and **U**nit **C**ategory (UC=) attributes. Most parameters will have a value. There is no required order to the attributes for either objects or parameters.

In its simplest form, OpenBrIM data used to describe a bridge component consists of an object with an easily recognized name. All of the parameters used to describe the object also have easily recognized names. The 3D representation of the rectangular footing example shown in Figure 2, is completely defined with the following data definition:

```
<O N="RectangularFooting" T="Project">
  <P N="Length" V="120" D="Footing Length (Along Bridge Alignment)" />
  <P N="Width" V="192" D="Footing Width (Transverse to Bridge Alignment)" />
  <P N="Depth" V="48" D="Footing Depth" />
  <P N="FootingConcrete" V="Concrete f'c 4 ksi" T="Material" />
  ...
</O>
```

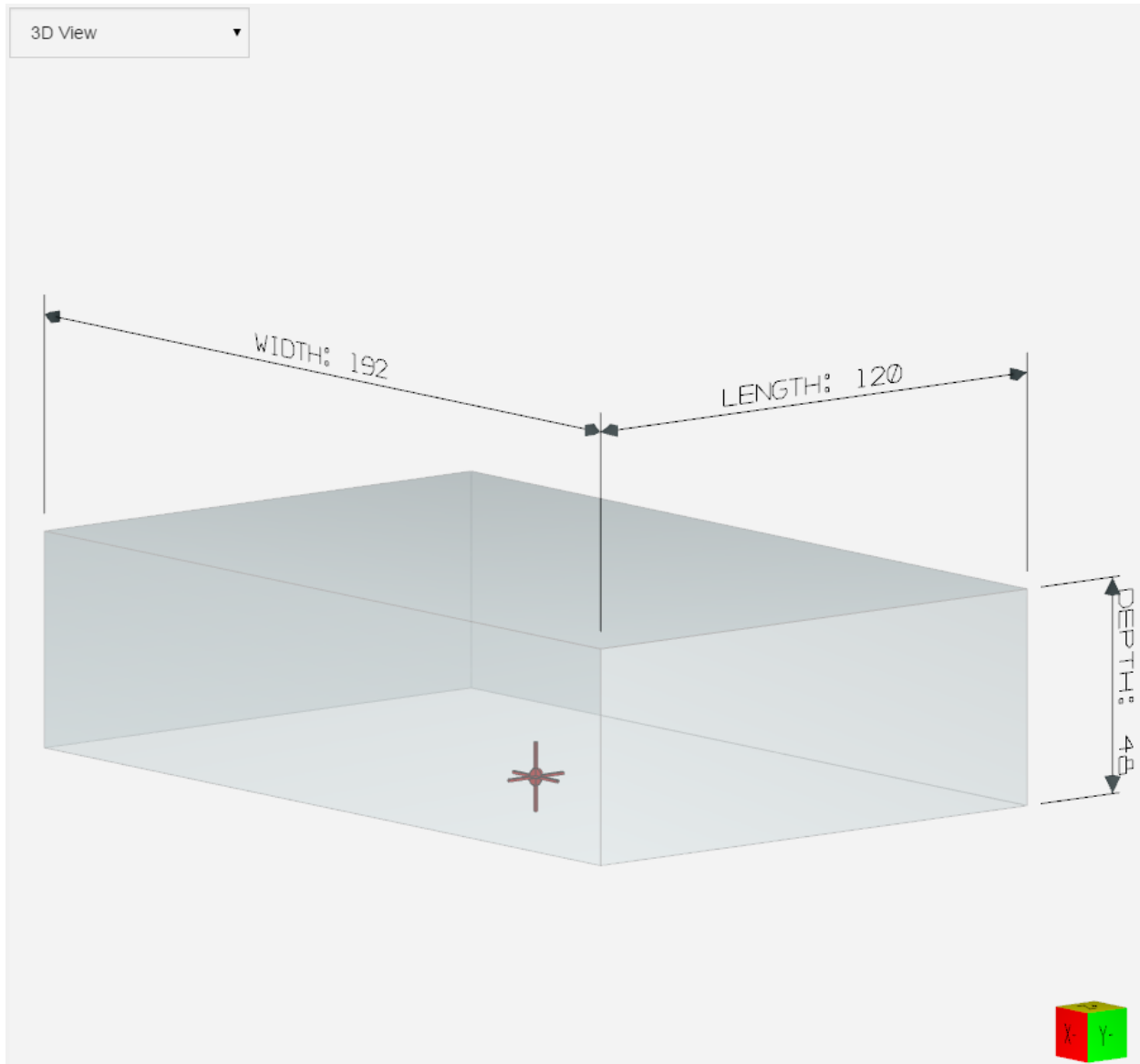

Figure 2 - Rectangular Footing Template View in OpenBrIM Library

There are additional lines of code in the template file required to create the graphical representation of the footing in the OpenBrIM application, and these features will be defined further in subsequent sections of the report. For other software applications, it is up to the developer to create the graphical representation of the component based only on the data defined. In describing the overall OpenBrIM

concept, the important point is that a small number of parameters with logical names can be used to describe a bridge component.

The object definition line for the rectangular footing example has both a name and type attribute. The type attribute, T="Project", is used as the first line of any template file. There is only one object with the project designation type allowed in any template file. However, a full bridge project model file can reference multiple component object templates, simply by using an object tag with the type attribute set to the name attribute of the component object.

```
<O N="Pier2Footing" T="RectangularFooting">
  <P N="Length" V="84" D="Footing Length (Along Bridge Alignment)" />
  <P N="Width" V="246" D="Footing Width (Transverse to Bridge Alignment)" />
  <P N="Depth" V="48" D="Footing Depth" />
  <P N="FootingConcrete" V="Concrete f'c 4 ksi" T="Material" />
</O>
```

Note that the three parameters used to describe the footing dimensions have different values than those from the template file. When referencing a component object from a project file, the values of the parameters from the project file override those in the component template. While the dimensions are not visible in the graphical project view (see Figure 3), they are visible in the parameter window on the right hand side of the figure.

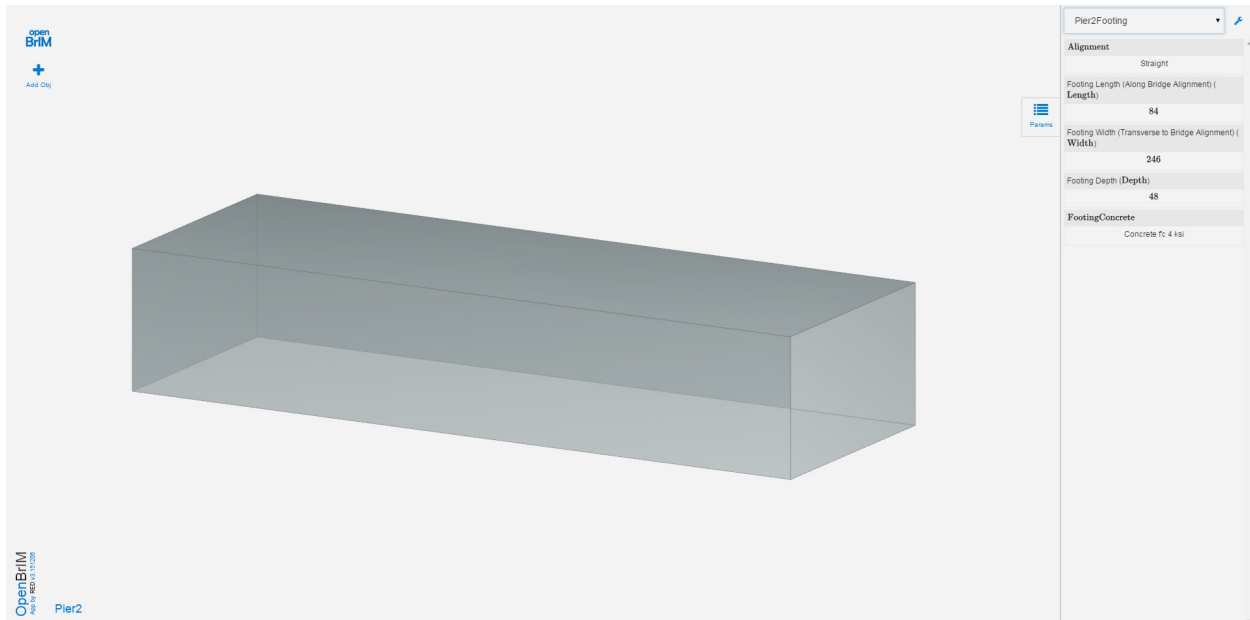

Figure 3 – Pier2Footing Shown in a Project

When an object is selected by clicking on it in the project window, it is highlighted in red, and the dimensions from the library are displayed on the view (see Figure 4).

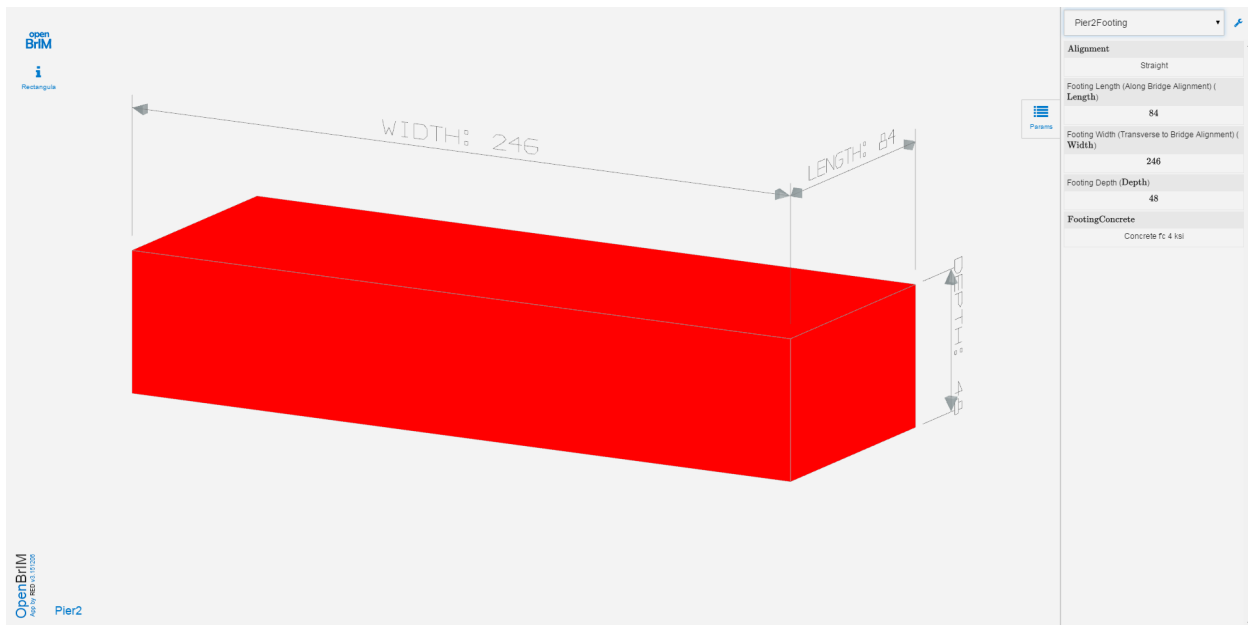

Figure 4 – Pier2Footing Selected Inside Project

While the previous example is for a simple object, it demonstrates how the process is intended to work. The more complex the component, the more data parameters required to properly define it.

## 3.4 Centralized Data Repository

One of the fundamental principles of the OpenBrIM concept is the use of an open bridge object data repository for BrIM models. This repository is currently organized as a central database on cloud. However, it has been designed as a distributed system where the leading organizations such as FHWA, state DOTs, standards organizations, etc., can host and manage their own open bridge libraries. These objects can be discovered and used by the community by sharing a simple URL.

OpenBrIM takes advantage of the already proven technologies of the IT industry to create a collaborative and secure environment. Information can be exchanged in XML format. Optionally, software vendors and end users can access the information directly online via a RESTful API. This API allows any authenticated user or application to interact with OpenBrIM data through simple web requests. Instead of file exchange, the data can be accessed directly from the hosting server. It is also possible to use OpenBrIM Connect, a free library developed and maintained by the OpenBrIM community allowing .NET and COM based applications to access the OpenBrIM object model. Using this library, software providers and/or the bridge industry community can create plug-ins/add-ons to integrate OpenBrIM into software applications utilized every day. Currently, open source plug-ins for AutoDesk AutoCAD, Bentley MicroStation, LARSA 4D and CSI SAP 2000 are available and it is expected and encouraged that more plug-ins be created by the community.

OpenBrIM is designed to work with OAuth and OpenID technologies to provide an open, and secure authentication experience. These technologies allow OpenBrIM to seamlessly integrate with existing user account management systems. Users can authenticate at their end and use OpenBrIM with their native organization account. This is expected to be an increasingly important feature as more of the organizations move to cloud based systems such as Google Apps and Office 365. All system components are designed to operate on SSL, a standard encrypted secure method for communication security.

OpenBrIM provides a version controlled data management back-end where no change to the project ever gets lost. The evolution of the project can be viewed through time along with the users who make the change and why the change has been made at each step.

The real advantage of a centralized data repository is the ability to eliminate the physical exchange of files between different participants. It does require that all software applications intended to access and update the model have the ability to read and write data in a single standardized format.

Ownership and stewardship of the centralized data repositories is yet to be determined. These details are an administrative issue that will need to be decided collaboratively by FHWA, AASHTO, and the rest of the bridge community. One possibility is that it becomes the responsibility of the FHWA or their designee. However, there are other options that should be investigated. The main focus of this report is on the technical aspects of the OpenBrIM approach.

## 3.5 Community Driven

Another key to OpenBrIM is the community driven concept, which is intended to promote collaboration. With this approach, the bridge component library objects are expected to be developed by bridge practitioners, including:

- Design engineers
- CADD technicians
- Software developers
- Steel fabricators
- Precast industry personnel
- Contractors
- Component manufacturers
- Owner's inspection, maintenance, and asset management staff

In addition to developing standard library objects, practitioners are needed to review and comment on proposed standards.

It is envisioned that an OpenBrIM organizational board will be established to moderate discussion and accept proposed objects for testing and standardization. Establishment of an OpenBrIM board is also an administrative issue to be decided by FHWA, AASHTO, and the rest of the bridge community.



# Section 4 – OpenBrIM Applications

## 4.1 Purpose

Although bridge information modeling is primarily management of the data associated with a bridge and its components, the data is easier to understand if it can be displayed graphically. Therefore it became a goal of the current work to not only define standard ways of describing bridge components and their data, but to have a robust tool to display those components in a graphical environment. OpenBrIM Version 3 is comprised of two modules – OpenBrIM App and OpenBrIM Library. The library tool is dedicated to creating 3-D bridge component objects from simple drawing primitives, whereas the OpenBrIM App is used to assemble entire bridge models from the library’s 3-D component objects. The App and Library are principally validation tools. If an object can be displayed graphically within the OpenBrIM applications, then it should also be capable of being modeled by other dedicated applications.

Neither of these tools are intended to take the place of existing 3-D bridge modeling applications that are already in use by engineers and owners. Traditional functions like high-resolution visualization, structural analysis and design, and clash detection, are intended to remain with the proprietary software vendors. OpenBrIM’s purpose is to facilitate interoperability between application platforms and users via an industry accepted data structure.

OpenBrIM has been primarily developed and tested on Google Chrome, however it also supports Internet Explorer version 11 or higher and Mozilla Firefox. It can run on a wide variety of platforms such as Mac OSX, Apple IOS, Android, and Microsoft phones and tablets. Access to OpenBrIM is free and available to anyone interested in collaborating with bridge industry colleagues by registering at the following URL:

<http://openbrim.org>

First time users must create an account by clicking on the button “Create an Account” on the opening screen shown in Figure 5, then completing the information requested in Figure 6. Once registered, returning users enter an email address and password for access.

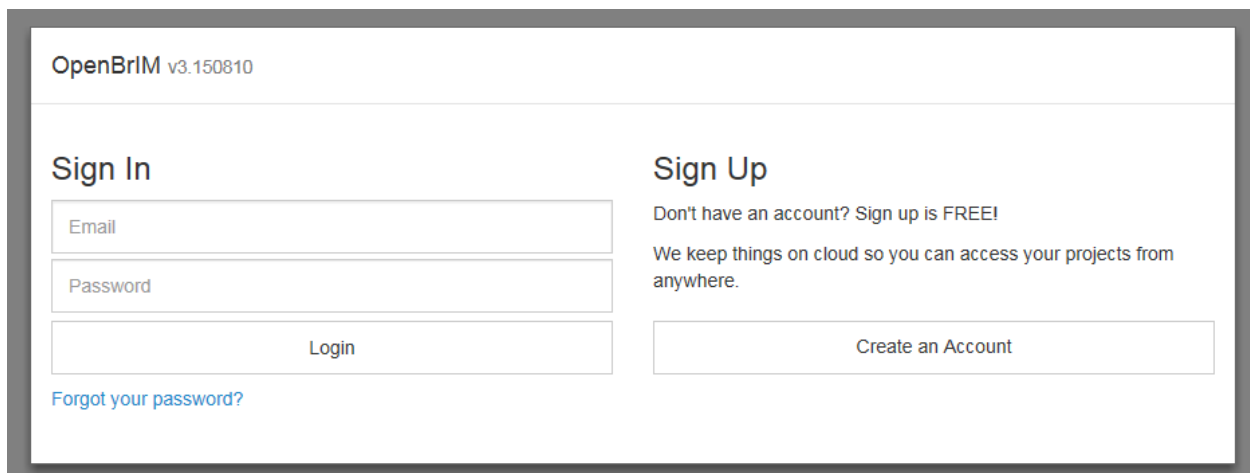

OpenBrIM v3.150810

**Sign In**

Email

Password

Login

[Forgot your password?](#)

**Sign Up**

Don't have an account? Sign up is FREE!

We keep things on cloud so you can access your projects from anywhere.

Create an Account

Figure 5 - OpenBrIM Opening Screen

The image shows a web form titled "Sign Up". At the top right, there is a link: "Already have a OpenBrIM account? Sign in now". The form contains the following input fields:

- Email
- Password
- First Name
- Last Name
- Organization
- Address
- Country
- Phone

At the bottom of the form is a "Sign Up" button.

Figure 6 - Initial Registration Screen

Registration provides use of the OpenBrIM App to create projects and library objects, and read-only access to other user's library objects. Being able to view other's library objects provides the perfect platform for collaboration. Users can copy those objects into their own library and experiment with them by making modifications or using portions of the code to develop their own similar objects.

#### 4.1.1 OpenBrIM Library

The Library App is a vital tool in the OpenBrIM concept. It is used for development of bridge component objects, which are the essential building blocks of BrIM models. Authors must determine a list of parameters to describe the object, write the ParamML code to display it, then document it properly. The OpenBrIM Library becomes the central repository for all bridge component objects.

The Library App has two windows (see Figure 7). The left window displays text, and the right displays graphics.

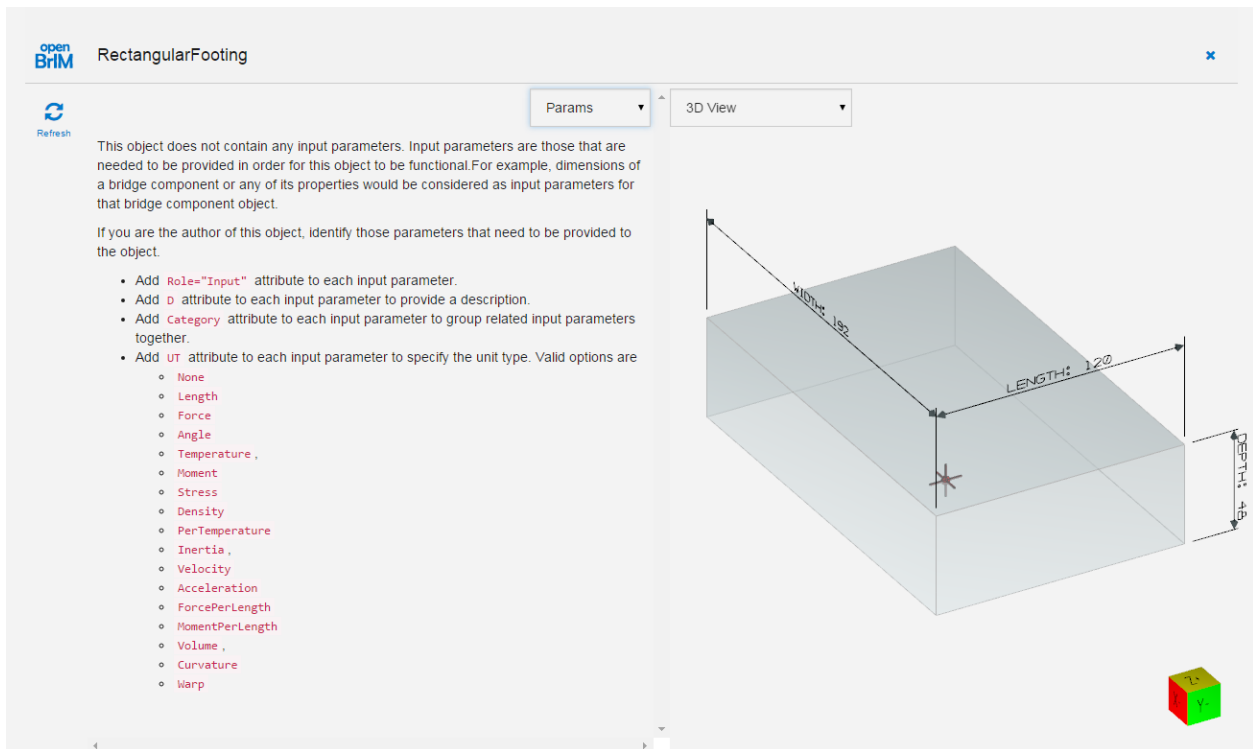

Figure 7 - OpenBrIM Library App Layout

In addition to being used to create component objects which are displayed in 3-D views, OpenBrIM Library is used to develop documentation to assist authors and reviewers to understand how the object is constructed and referenced from projects. The dropdown list in the text window includes three items specifically directed to documentation.

- **Docs** describes the purpose of the object and should be used to identify special features or limitations on its use (see Figure 8).

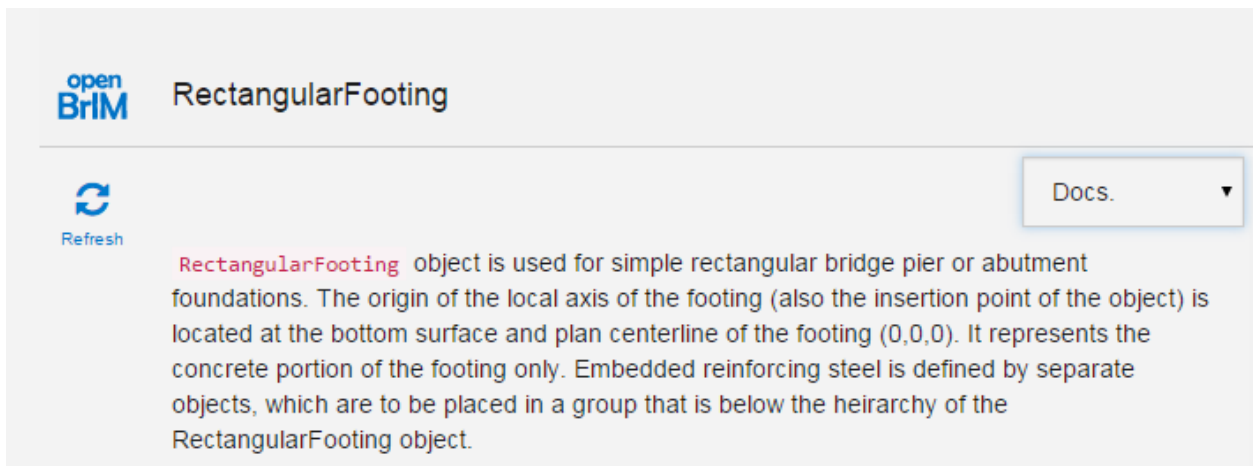

Figure 8 - Library Object Description

- **Params** identifies all of the parametric values used to define the object. By adding the attribute **Role="Input"** to key input parameters, they are automatically added to the Params screen to facilitate editing the data (see Figure 9). If there are a large number of parameters, they can be grouped by using the **Category** attribute. Multiple category names can be assigned for clarity and convenience.



Figure 9 - Library Object Parameters

- **XML View** contains the code to graphically display the object (see Figure 10). Lines 8-15 of the code are all that are needed to describe a rectangular surface extruded into a solid object by defining a thickness.

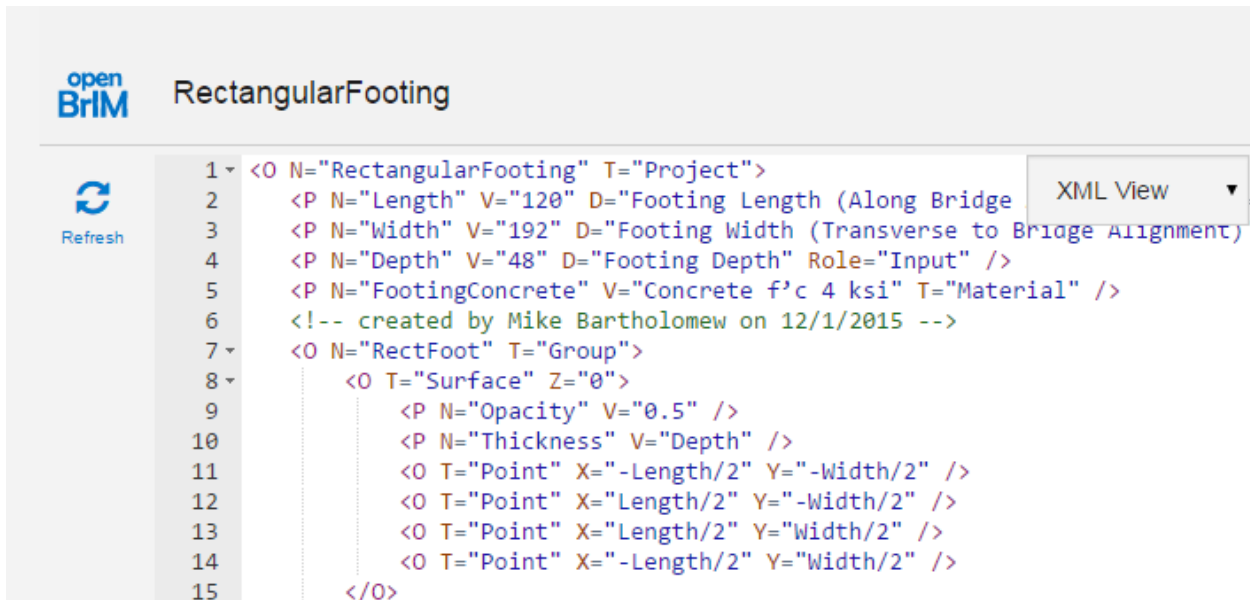

Figure 10 - XML Code

The graphical view in the right window is also considered a part of library object documentation. It includes the display of dimensions in the 3-D views. As the dimensional parameters are edited interactively, the graphical view is updated automatically.

In addition to the 3-D view, OpenBrIM has basic CADD graphics capabilities. CADD views can be created from scratch, or by using a special object called "CADDFrom3D, which can create views directly from the 3-D view. CADDFrom3D will incorporate dimensions developed on the 3-D view. Both of these methods assist in documentation.

The text window dropdown list also includes two items to assist in the process of object standardization: **Status** and **Discussions**. Objects must pass through the following series of steps to become a standard OpenBrIM object.

1. **In Development:** Object is currently under development.
2. **Proposed:** Object is open for community review.
3. **Accepted:** Object is accepted by the OpenBrIM board towards standardization.
4. **Incubation:** Object is in testing period.
5. **Standard:** Object is part of the OpenBrIM standard.

Objects are open to review and discussion from the bridge engineering community at all times. Discussions are moderated by the OpenBrIM board.

All objects created by authors have the initial status “In Development”. When the author determines that the object is adequately developed and fully documented, he or she can change the status to “Proposed”, and the object is opened for review and discussion. All comments by reviewers are emailed to the author, and are also recorded in the Discussions section of the object. When all comments and questions are resolved, the object is submitted to the OpenBrIM board for acceptance towards standardization. Upon board “Acceptance”, the object is opened up for a testing period, which will also generate review comments and discussion. Steps to achieve OpenBrIM “Accepted” and “Standard” status will require passing a set of criteria that is yet to be determined.

### 4.1.2 OpenBrIMApp

The OpenBrIM App is a modeling tool that works in conjunction with the OpenBrIM Library to create full bridge models. A project file is typically comprised only of object references to library component objects and their associated parameters. The object parameter data in the project file replaces the default data in the library file. While component objects can be created with the OpenBrIM App, those components are not accessible to other projects, which would result in a lot of copying of XML code from one project to the next. The real function of the OpenBrIM App is to place and orient component library objects in the bridge model with respect to the bridge alignment. Knowing the origin or reference insertion point of a library object, it can be positioned in the bridge model according to its longitudinal station, horizontal offset, and elevation. The object can be oriented so that its own local coordinate system is tangent, perpendicular or skewed to the horizontal alignment. And library objects such as bridge girders can be defined to follow horizontal or vertical curves as well as chorded through their endpoints. Girders can also be placed plumb or perpendicular to the roadway surface. A particularly useful feature is the ability for a bridge deck warp to follow a varying superelevation transition. How all of these features work will be described in Section 5 and 6 when describing bridge component modeling.

Objects in OpenBrIM can be grouped to follow a hierarchical scheme, where features or properties of higher order objects are inherited by lower order objects. Parameter data can be designated by categories to help organize input more clearly. Object groups are particularly useful for viewing exploded views of a project to more easily visualize connectivity of components.



# Section 5 – Bridge Component Modeling

## 5.1 Basic Geometric Constructs

The building blocks of an OpenBrIM model are the individual bridge component library objects. There are several basic types of objects that are used to graphically describe bridge components – Point, Surface, Volume, Line, Circle, Shape and Section. Every component can be constructed with these simple elements.

Point objects are used to define the end locations of Lines and the perimeter of Shape and Surface objects. A Shape object is defined in a 2-D plane using only X and Y coordinates. Neither Point nor Shape objects display graphically on their own in 3-D views. They are only used to construct other objects.

Section objects are created from one or more Shape objects, and do not display graphically in 3-D views either. A hollow Section object is constructed from two Shape objects, one defining the outside perimeter, and the other the hollow void. Figure 11 shows a typical hollow box beam Section object constructed from two Shape objects. The graphic was created using the 2-D CADD features of OpenBrIM, and depicts the input dimension parameters necessary to define the Section object.

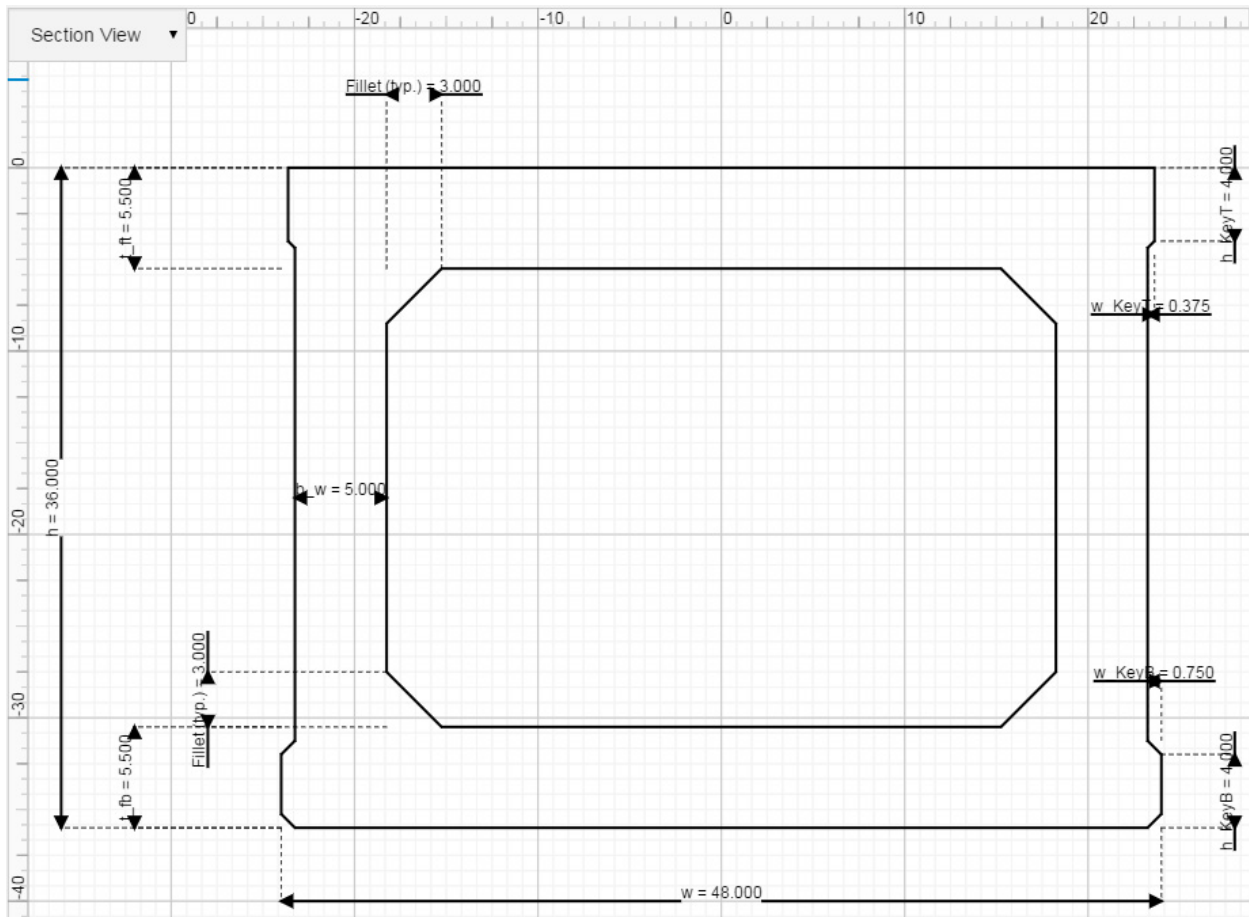

Figure 11 - Hollow Box Beam Section

The ParamML code to define the box beam is given in Figure 12. The input parameters are defined at the top of the file and correspond directly to those in the CADD graphic. A Shape object is constructed by defining the X and Y coordinates of the box beam perimeter. A second Shape object is constructed for the hollow void perimeter and uses the Parameter “IsCutOut” set equal to 1. These two Shape objects are placed within the Section object named “Hollow Box Beam”. The outside perimeter shape is defined first, followed by the void. Multiple voids can be defined. Note that when an object like this is developed as a standard library object, only the data defined with Role=“Input” is passed between a project file and the library. The ParamML code used to define the Shape, Section, and Line object is used only by the OpenBrIM App to create the 3-D graphic. Other software applications that access this data will use their own proprietary code routines to develop their graphic representations of the object.

```

1 <O N="HollowSectionExample" T="Project">
2 <!-- created by Mike Bartholomew on 12/11/2015 -->
3 <O N="Section Dimensions" T="Group">
4 <P N="w" V="48" D="overall width" Role="Input" Category="Section Dimensions" />
5 <P N="h" V="36" D="overall depth" Role="Input" Category="Section Dimensions" />
6 <P N="t_ft" V="5.5" D="Top flange thickness" Role="Input" Category="Section Dimensions" />
7 <P N="t_fb" V="5.5" D="Bottom flange thickness" Role="Input" Category="Section Dimensions" />
8 <P N="b_w" V="5" D="width of web" Role="Input" Category="Section Dimensions" />
9 <P N="Fillet" V="3" D="Inside fillet" Role="Input" Category="Section Dimensions" />
10 <P N="h_KeyT" V="4" D="Top key height" Role="Input" Category="Section Dimensions" />
11 <P N="t_KeyT" V="0.375" D="Top key width" Role="Input" Category="Section Dimensions" />
12 <P N="h_KeyB" V="4" D="Bottom key height" Role="Input" Category="Section Dimensions" />
13 <P N="w_KeyB" V="0.75" D="Bottom key width" Role="Input" Category="Section Dimensions" />
14 </O>
15 <O N="Hollow Box Beam" T="Section">
16 <O N="Perimeter" T="Shape">
17 <T="Point" Y="0" X="-w/2+w_KeyB-w_KeyT" />
18 <T="Point" Y="-h_KeyT" X="-w/2+w_KeyB-w_KeyT" />
19 <T="Point" Y="-h_KeyT-w_KeyT" X="-w/2+w_KeyB" />
20 <T="Point" Y="-h+h_KeyB+w_KeyB" X="-w/2+w_KeyB" />
21 <T="Point" Y="-h+h_KeyB" X="-w/2" />
22 <T="Point" Y="-h+w_KeyB" X="-w/2" />
23 <T="Point" Y="-h" X="-w/2+w_KeyB" />
24 <T="Point" Y="-h" X="w/2-w_KeyB" />
25 <T="Point" Y="-h+w_KeyB" X="w/2" />
26 <T="Point" Y="-h+h_KeyB" X="w/2" />
27 <T="Point" Y="-h+h_KeyB+w_KeyB" X="w/2-w_KeyB" />
28 <T="Point" Y="-h_KeyT-w_KeyT" X="w/2-w_KeyB" />
29 <T="Point" Y="-h_KeyT" X="w/2-w_KeyB+w_KeyT" />
30 <T="Point" Y="0" X="w/2-w_KeyB+w_KeyT" />
31 </O>
32 <O N="Void" T="Shape">
33 <P N="IsCutout" V="1" />
34 <T="Point" Y="-t_fb" X="-w/2+w_KeyB+b_w+Fillet" />
35 <T="Point" Y="-t_fb-Fillet" X="-w/2+w_KeyB+b_w" />
36 <T="Point" Y="-h+t_ft+Fillet" X="-w/2+w_KeyB+b_w" />
37 <T="Point" Y="-h+t_ft" X="-w/2+w_KeyB+b_w+Fillet" />
38 <T="Point" Y="-h+t_ft" X="w/2-w_KeyB-b_w-Fillet" />
39 <T="Point" Y="-h+t_ft+Fillet" X="w/2-w_KeyB-b_w" />
40 <T="Point" Y="-t_fb-Fillet" X="w/2-w_KeyB-b_w" />
41 <T="Point" Y="-t_fb" X="w/2-w_KeyB-b_w-Fillet" />
42 </O>
43 </O>
44 <O N="Girder 1" T="Line">
45 <P N="Opacity" V="0.75" />
46 <P N="Section" V="Hollow Box Beam" T="Section" />
47 <O T="Point" Z="0" Y="0" X="0" />
48 <O T="Point" Z="0" Y="0" X="480" />
49 </O>

```

Figure 12- ParamML Code for Hollow Section Line Object

Line objects are constructed from two Point objects (endpoints) and a Section object. The Section object is extruded between the two endpoints to make a 3-D object as shown in Figure 13. Sections are positioned normal to the line with their origin (0, 0) coincident with the line. The red line represents the actual endpoints of the line and is excluded from the actual object definition. It is shown to help clarify how the line extrusion works. Line objects are most often used when one dimension of a component is



significantly larger than the other two, the other two dimensions are constant, and the object is primarily horizontal. Bridge beams and girders are examples of components that are typically constructed using Line objects.

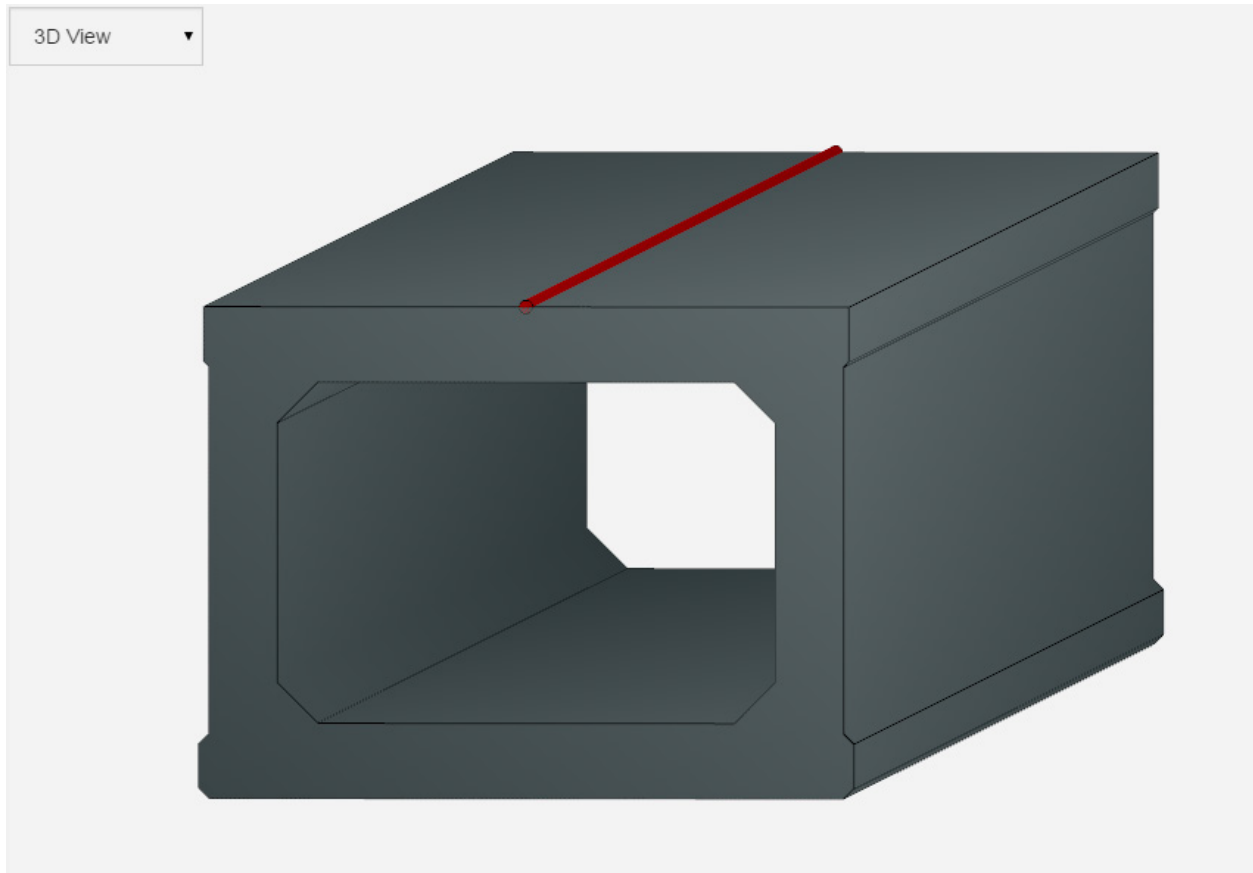

*Figure 13 – Line Object with Hollow Section*

A Surface object is similar to a Shape in that it must have all of its Point objects defined in a single plane. Unlike the Shape object, a Surface object is displayed graphically. An optional thickness parameter can be used to extrude the Shape into a 3-D object. The plane describing a Surface object can be oriented in 3-D space with additional Z coordinates for the Point objects. The first three points of a Surface define the 3-D plane of the object. All other points must be defined in that plane. Circle objects are a special case of a Shape object. Surface objects are most often used when one dimension is significantly smaller than the other two, and the other two are constant. Surface objects are ideal for defining steel plates with bolt holes, like the Bolted Gusset Plate shown in Figure 14.

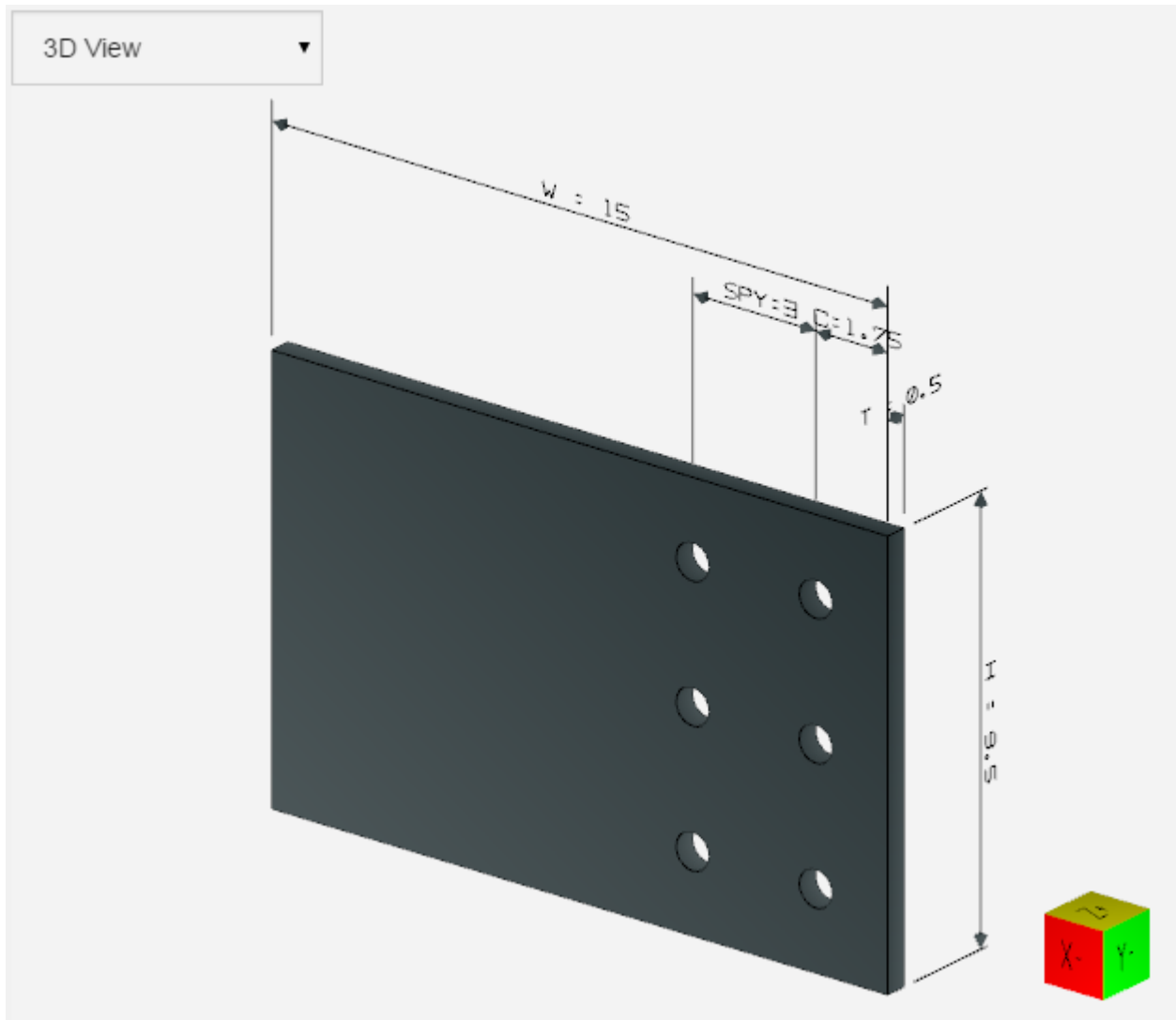

Figure 14 - Surface Object for Bolted Gusset Plate

Figure 15 shows the ParamML Code to define a Gusset Plate with bolt holes. As with the Line object, the input parameters are defined at the top of the file. The plate Surface object is constructed by simply defining the X and Y coordinates of the plate corners. In this case, the origin (0, 0, 0) or insertion point of the object is at the center of the plate on the plane of the defined surface, not the center of the thickness. A group of Circle objects are used to define the bolt holes. All holes have the Parameter "IsCutOut" set equal to 1. The plate outside perimeter is defined first, followed by the holes. A grid of holes are defined using nested Repeat objects, which are based on the number of rows, columns, and bolt spacing.

```

1 <O N="Bolted Gusset Test" T="Project">
2   <!-- created by Mike Bartholomew on 7/9/2015 -->
3   <O N="ObjDesc" T="Group">
4     <!--
5     <p> |Bolted Gusset Test| object is used for Cross Frame Gusset connection plates.
6     The plate is defined as a surface with thickness. It contain bolt holes as cutout
7     sub-surfaces. There are two nested Repeat objects that are used to create
8     holes in both Y and Z direction of the plate. The outer repeat is along the
9     Z axis (uses j control parameter) and the inner repeat is along Y axis
10    (uses i control parameter).spY and spZ are the spacing along Y and Z axis,
11    respectively. (locY, locZ) is the location of the hole.
12    </p>
13    -->
14    </O>
15    <O N="Plate Dimensions" T="Group">
16      <P N="w" V="15" D="width of the plate" Role="Input" Category="Plate Dimensions" />
17      <P N="h" V="9.5" D="height of the plate" Role="Input" Category="Plate Dimensions" />
18      <P N="t_g" V="0.5" D="thickness of the plate" Role="Input" Category="Plate Dimensions" />
19      <P N="nrows" V="3" D="number of horizontal rows" Role="Input" Category="Plate Dimensions" />
20      <P N="ncols" V="2" D="number of vertical columns" Role="Input" Category="Plate Dimensions" />
21      <P N="spY" V="3" D="horizontal spacing between bolt holes" Role="Input" Category="Plate Dimensions" />
22      <P N="spZ" V="3" D="vertical spacing between bolt holes" Role="Input" Category="Plate Dimensions" />
23      <P N="d_b" V="0.75" D="bolt diameter" Role="Input" Category="Plate Dimensions" />
24      <P N="c" V="1.75" D="clearance from edge" Role="Input" Category="Plate Dimensions" />
25    </O>
26    <O N="Plate" T="Group">
27      <O T="Surface">
28        <P N="Thickness" V="t_g" />
29        <P N="r" V="(d_b+1/16)/2" D="radius of bolt hole" />
30        <O T="Point" Y="w/2" Z="-h/2" />
31        <O T="Point" Y="-w/2" Z="-h/2" />
32        <O T="Point" Y="-w/2" Z="h/2" />
33        <O T="Point" Y="w/2" Z="h/2" />
34        <O T="Repeat" S="0" I="1" E="nrows-1" CTRL="j" j="0">
35          <O T="Repeat" S="0" I="1" E="ncols-1" CTRL="i" i="0">
36            <P N="locY" V="-w/2 + c + spY * i" D="Y location of the bolt hole" />
37            <P N="locZ" V="-h/2 + c + spZ * j" D="Z location of the bolt hole" />
38            <O T="Circle" Y="locY" Z="locZ" RY="PI/2">
39              <P N="IsCutout" V="1" />
40              <P N="Radius" V="r" />
41              <P N="Segments" V="20" />
42            </O>
43          </O>
44        </O>
45      </O>

```

Figure 15 - ParamML Code for Bolted Gusset Plate Surface Object

Volume objects are constructed by connecting Surface objects. Each Surface object is required to have the same number of points around the perimeter for proper extrusion. The Surface objects do not have to be in parallel planes. Simple Volume objects are constructed from two Surface objects. More complex Volume objects can be constructed from three or more connecting Surface objects. Volume objects are often used when components are non-prismatic or otherwise irregular. The following example of a doubly tapered bridge pier exhibits the power of the Volume object. The base of the column is a 48" wide by 96" deep rectangular shape with 6" chamfered corners. It has a longitudinal slope that decreases the width of the section to 24", and a transverse slope that increases the depth of the section to 144" with height. Figure 16 shows the elevation views with intended dimensions, Figure 17 shows the ParamML coding, and Figure 18 shows the 3-D representation of the tapered column.

Another type of Volume object is constructed similar to a Line object, by defining a Section object that connects two Point objects. This is most commonly used for defining primarily vertical members like pier columns.

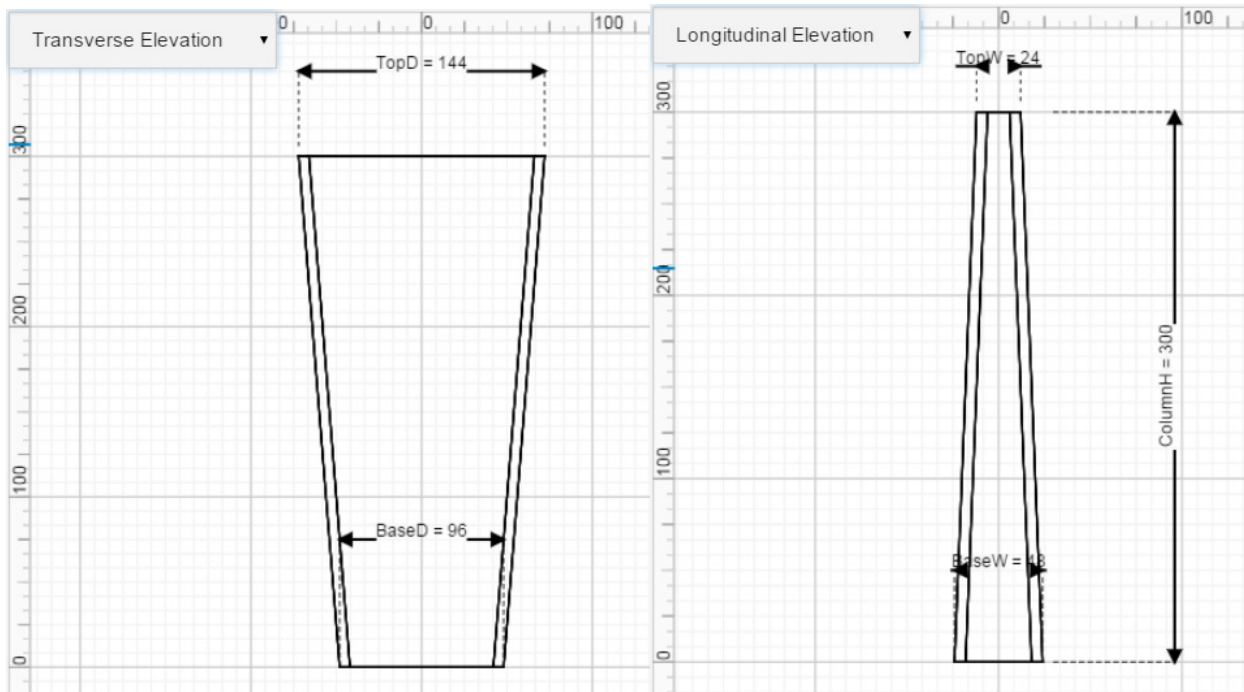

Figure 16 - Tapered Column Elevation Views

open  
Brim

TaperedColumn by Mike Bartholomew

Refresh

XML View

```

1 <O N="TaperedColumn" T="Project">
2   <P N="BaseW" V="48" Role="Input" />
3   <P N="BaseD" V="96" Role="Input" />
4   <P N="TopW" V="24" Role="Input" />
5   <P N="TopD" V="144" Role="Input" />
6   <P N="Chamfer" V="6" Role="Input" />
7   <P N="ColumnH" V="300" Role="Input" />
8   <P N="Opacity" V="0.7" />
9   <!-- created by Mike Bartholomew on 12/13/2015 -->
10  <O N="Column" T="Group">
11    <O N="Volume1" T="Volume">
12      <O T="Surface" Z="0">
13        <O T="Point" X="-BaseW/2" Y="-BaseD/2" C="Chamfer" />
14        <O T="Point" X="BaseW/2" Y="-BaseD/2" C="Chamfer" />
15        <O T="Point" X="BaseW/2" Y="BaseD/2" C="Chamfer" />
16        <O T="Point" X="-BaseW/2" Y="BaseD/2" C="Chamfer" />
17      </O>
18      <O T="Surface" Z="ColumnH">
19        <O T="Point" X="-TopW/2" Y="-TopD/2" C="Chamfer" />
20        <O T="Point" X="TopW/2" Y="-TopD/2" C="Chamfer" />
21        <O T="Point" X="TopW/2" Y="TopD/2" C="Chamfer" />
22        <O T="Point" X="-TopW/2" Y="TopD/2" C="Chamfer" />
23      </O>
24    </O>
  </O>

```

Figure 17 - ParamML Code for Tapered Column Volume Object

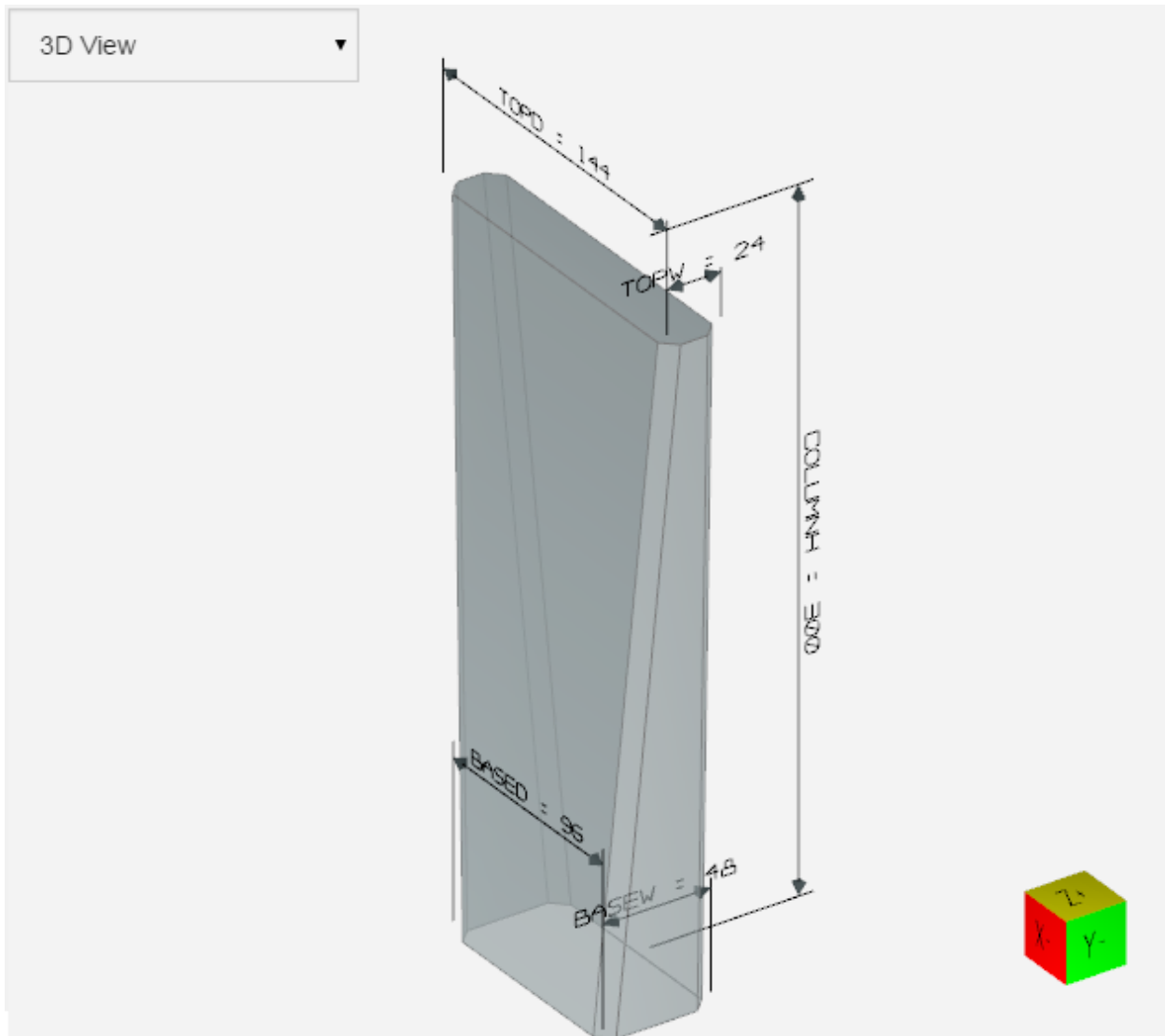

Figure 18 - Volume Object for Tapered Column

## 5.2 Parametric Modeling

Many bridge components have been developed into standards by the various public agency Departments of Transportation and Industry organizations. Virtually every state agency has a set of standards for precast, prestressed concrete girders. Typically these standards include at least one drawing showing the girder cross section, elevation, and plan views (see excerpt in Figure 19). A second drawing usually has a table for including data to describe dimensions, number of prestressing strands, and reinforcing bar sizes and spacing (see excerpt in Figure 20). These tables include a list of all of the parameters necessary to completely describe each girder on the project. Drawing standards like these are representative of the type of bridge component ideally suited for parametric modeling.

SECTION 5 – BRIDGE COMPONENT MODELING

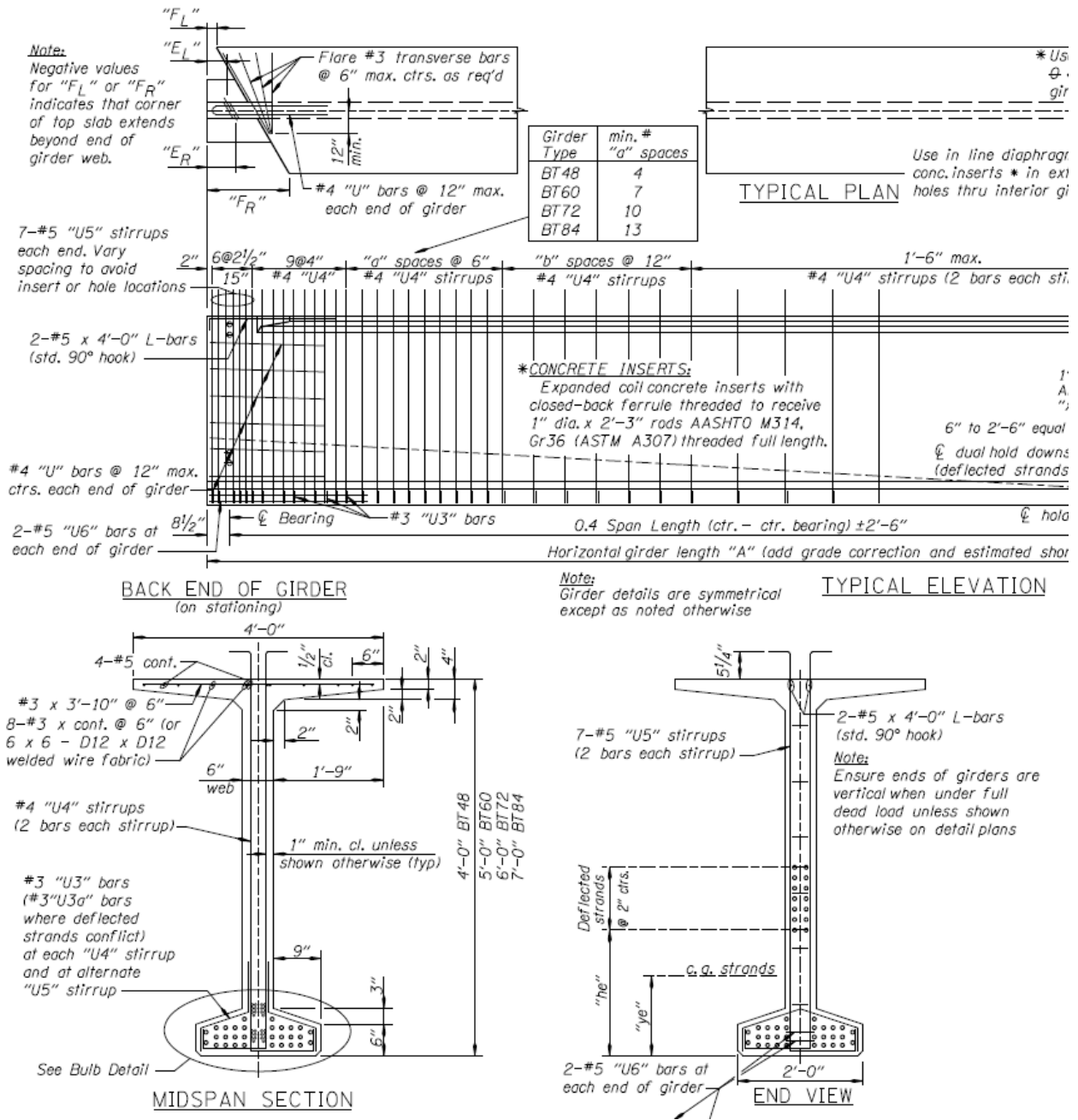

Figure 19 - Precast Girder Standard Drawing



## 5.3 Units

All models use an internal system of units for storing data as shown below:

```
<O N="Units" T="Group">
  <O N="Internal" T="Unit">
    <P N="Length" V="INCH" T="Text" />
    <P N="Force" V="KIPS" T="Text" />
    <P N="Angle" V="RADIANS" T="Text" />
    <P N="Temperature" V="FAHRENHEIT" T="Text" />
  </O>
  .
  .
  .
```

The internal unit for length is the inch and for angle is radians. Many bridge components are more conveniently described with length units of feet (e.g., span lengths, girder spacing, and elevations) or with angular units of degrees (e.g., skew). New Units group definitions are allowed to be applied to a model for clarity, by inserting a new object with the type attribute of Unit. The new definition, named “Layout” is inserted in the Group named “Units”.

```
  .
  .
  .
  <O N="Layout" T="Unit">
    <P N="Length" V="FEET" T="Text" />
    <P N="Force" V="KIPS" T="Text" />
    <P N="Angle" V="DEGREES" T="Text" />
    <P N="Temperature" V="FAHRENHEIT" T="Text" />
  </O>
</O>
```

When defining new Parameter objects where it is desired to use length units of feet instead of the inch internal system units, the definition needs to include attributes UT=“Length” and UC=“Layout”.



## 5.4 Alignment

Every component in a bridge can be located and oriented with respect to the roadway geometric alignment and cross section, which makes it one of the most important elements in the process of developing a BrIM model. The Alignment object and its Horizontal, Vertical and Cross Slope segments are basic built-in components of the OpenBrIM App. Figure 22 shows an exaggerated alignment containing all the various types of alignment definitions that can be modeled. In plan, the horizontal alignment includes a tangent section followed by spiral, circular, and spiral curves, then ends in a tangent section. Vertically, there is a constant upward grade transitioning through a parabolic vertical curve into a downward grade. The cross slope starts with a crown, then warps through the spiral curve to constant superelevation in the circular curve, then warps back to a crown through another spiral curve, then remains in a crown to the end. The red line in the longitudinal direction represents the Horizontal Control Line (HCL), and the red lines in the transverse direction represent break points in the Cross Slope. The shaded surface defines the entire roadway section and follows the horizontal and vertical curves, and warps to any superelevation transitions.

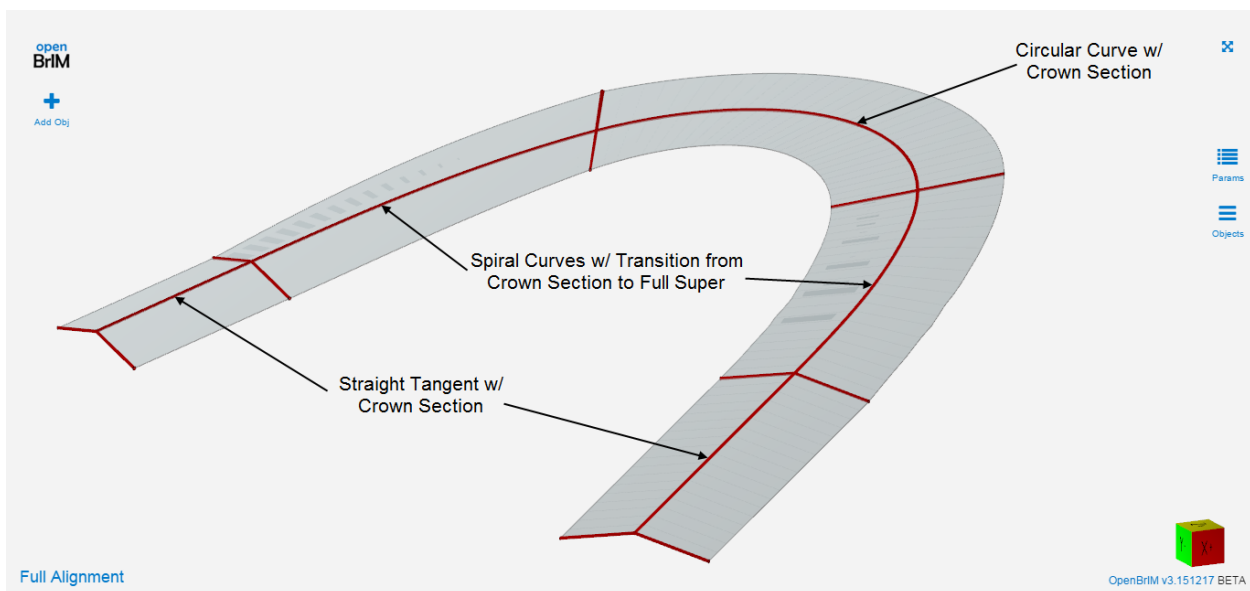

Figure 22 - Example Alignment

Most of the development work undertaken in this project was done using an example steel girder bridge provided by the FHWA. The project is Ramp 119 S-N over S.R. 51 on the Mon/Fayette Expressway, Uniontown to Brownsville Section, owned by the Pennsylvania Turnpike Commission. Plans were produced in 2008. The structure is a three-span (130'-180'-130') steel I-girder bridge on a horizontal alignment with a 764' radius section combined with a tangent section, a vertical 5.79% grade combined with a 550' vertical curve, and superelevation variation from 8% to 2% in five transitions. This geometry will be used to demonstrate how the alignment for an OpenBrIM model is developed.

The basic Alignment object requires a Name along with Station, and Azimuth Parameters. Azimuth 0 is defined as North, and displays the Y-direction in the X-Y plane shown on the computer screen. The Ramp 119 S-N project definition is shown below.

```
<O N="BL119S_N" T="Alignment">
  <P N="Station" V="6000*12" UT="Length" UC="Layout" />
  <P N="Azimuth" V="PI/2" UT="Angle" UC="Layout" />
  .
  .
```

</O>

The actual start station of the alignment is defined as 60+00 (in feet). The Value,  $V=6000 \times 12$ , is an expression which converts to 72000, and is stored in the internal inch units. The UT="Length" and UC="Layout" as discussed in Section 5.3, will display those units as feet in the program interface. The Azimuth value of  $\text{PI}/2$  ( $\pi/2$ ) or  $90^\circ$  defines the start of the alignment along the X-direction in the X-Y plane.

### 5.4.1 Horizontal Segment

Each Alignment object must contain one or more Horizontal Segment objects to define the Horizontal Control Line (HCL). Multiple segments can be stacked up in order to define the full horizontal alignment. Segment types can be either Straight, Circular, or Spiral. Straight segments need only a length parameter. In addition to a length parameter, a circular curve requires radius and direction parameters. The direction describes whether the alignment curves left or right when looking upstation.

The horizontal alignment for Ramp 119 S-N, shown in Figure 23, includes a right 764' radius circular curve at the start of the alignment, followed by a tangent section. The horizontal curve data is magnified in Figure 24.

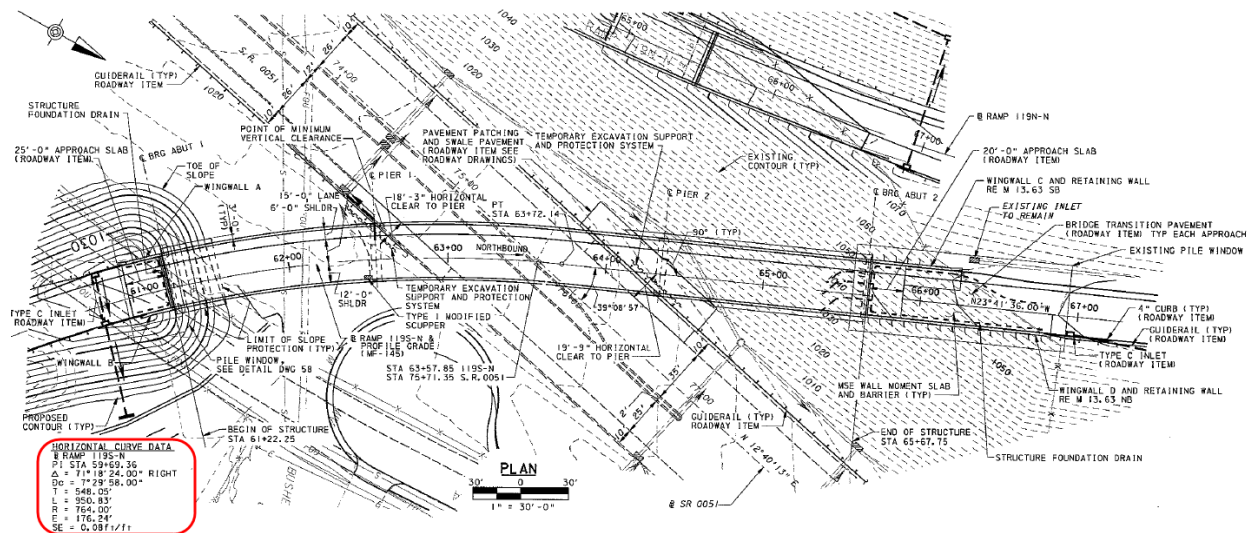

Figure 23 - Ramp 119 S-N Horizontal Alignment

HORIZONTAL CURVE DATA	
RAMP 119S-N	
PI STA	59+69.36
$\Delta$	$71^\circ 18' 24.00''$ RIGHT
$D_c$	$7^\circ 29' 58.00''$
T	548.05'
L	950.83'
R	764.00'
E	176.24'
SE	$0.08 f_t / f_r$

Figure 24 - Ramp 119 S-N Horizontal Curve Data

The ParamML code to create the entire horizontal alignment is shown below and contains only eight lines. The alignment starts and end beyond the ends of the bridge.

```

<O N="Curve_101" T="Circular">
  <P N="Length" V="372.14*12" UT="Length" UC="Layout" />
  <P N="Radius" V="764*12" UT="Length" UC="Layout" />
  <P N="Direction" V="Right" T="Text" />
</O>
<O N="TangentSeg_1" T="Straight">
  <P N="Length" V="602.86*12" />
</O>

```

Figure 25 shows a plan view of the alignment from the OpenBrIM App. The red line represents the HCL.

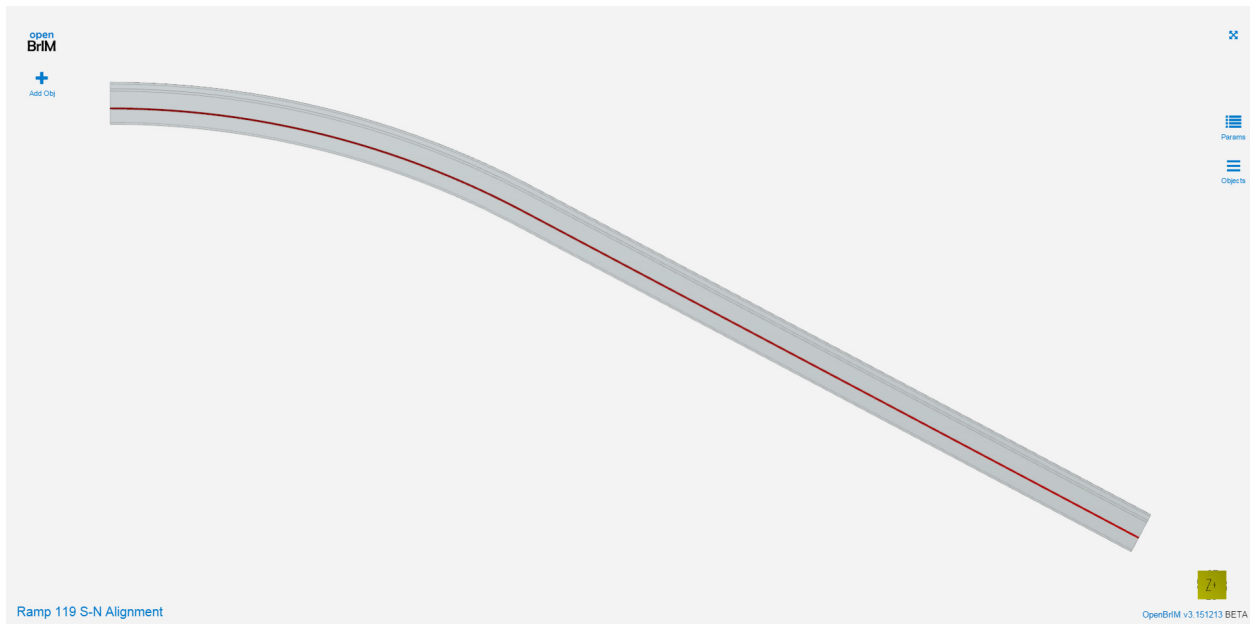

Figure 25 – Ramp 119 S-N Horizontal Alignment in OpenBrIM

## 5.4.2 Vertical Segment

Each Alignment object must contain one or more Vertical Segments to define the Profile Grade Line (PGL). Vertical geometry is specified by ElevationPoint objects with parameters Station, Grade, and Elevation. If multiple ElevationPoint objects are defined, they must be listed in order of increasing Station parameters. The vertical profile is constructed with parabolic vertical curves fit between the defined points. Figure 26 shows a vertical elevation view of the Ramp 119 S-N structure. The vertical profile data circled in red is shown magnified in Figure 27.

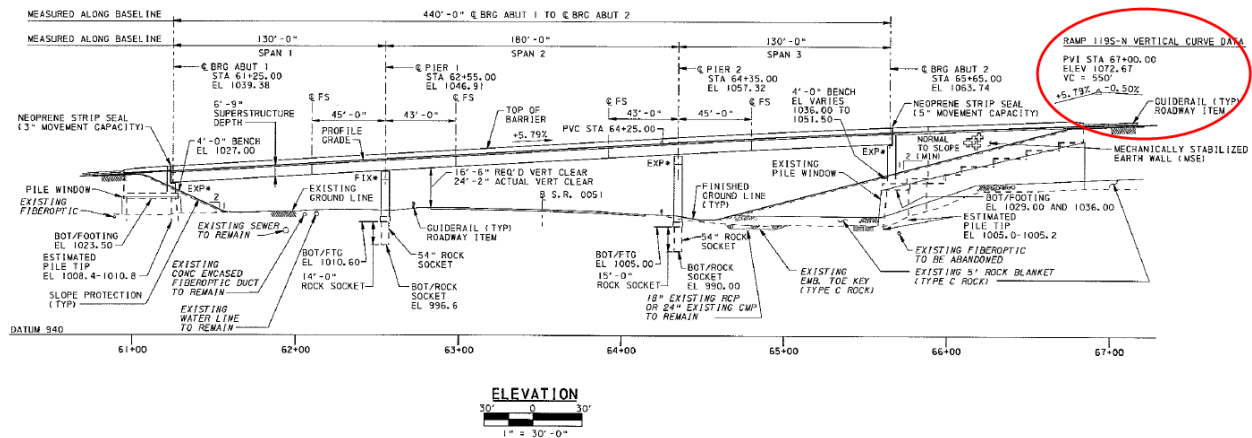

Figure 26 - Ramp 119 S-N Vertical Profile

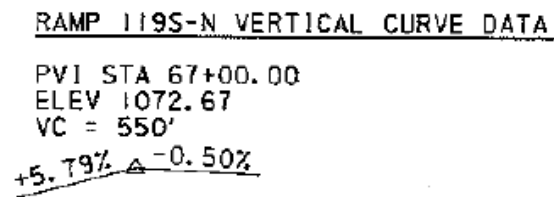

Figure 27 - Ramp 119 S-N Vertical Curve Data

Only three points are required to define the Ramp 119 S-N structure in OpenBrim. The first point corresponds to the beginning of the horizontal alignment. The second and third points define the VPC and VPT of the curve. The ParamML code is as follows:

```
<O N="Begin" T="ElevationPoint">
  <P N="Station" V="6000*12" UT="Length" UC="Layout" />
  <P N="Grade" V="0.0579" />
  <P N="Elevation" V="1032.14*12" UT="Length" UC="Layout" />
</O>
<O N="VPC_1" T="ElevationPoint">
  <P N="Station" V="6425*12" UT="Length" UC="Layout" />
  <P N="Grade" V="0.0579" />
  <P N="Elevation" V="1056.75*12" UT="Length" UC="Layout" />
</O>
<O N="VPT_1" T="ElevationPoint">
  <P N="Station" V="6975*12" UT="Length" UC="Layout" />
  <P N="Grade" V="-0.005" />
  <P N="Elevation" V="1067.795*12" UT="Length" UC="Layout" />
</O>
```

Figure 28 shows a developed elevation of the vertical profile in the OpenBrIM App.



Figure 28 – Ramp 119 S-N Vertical Profile in OpenBrIM

### 5.4.3 Cross Slope Segment

The roadway cross section can also be specified as part of the alignment data using one or more Cross Section objects. A Cross Section object must contain one or more Cross Section Segment objects, defined with a cross-slope and a segment width. Looking up station, starting from the left side, Cross Section Segment objects are stacked to define the cross-section. Figure 29 shows the Ramp 119 S-N contains 4 cross slopes, G1 to G4. These sections vary along the length of the bridge as defined by the table of cross slopes identified below the figure.

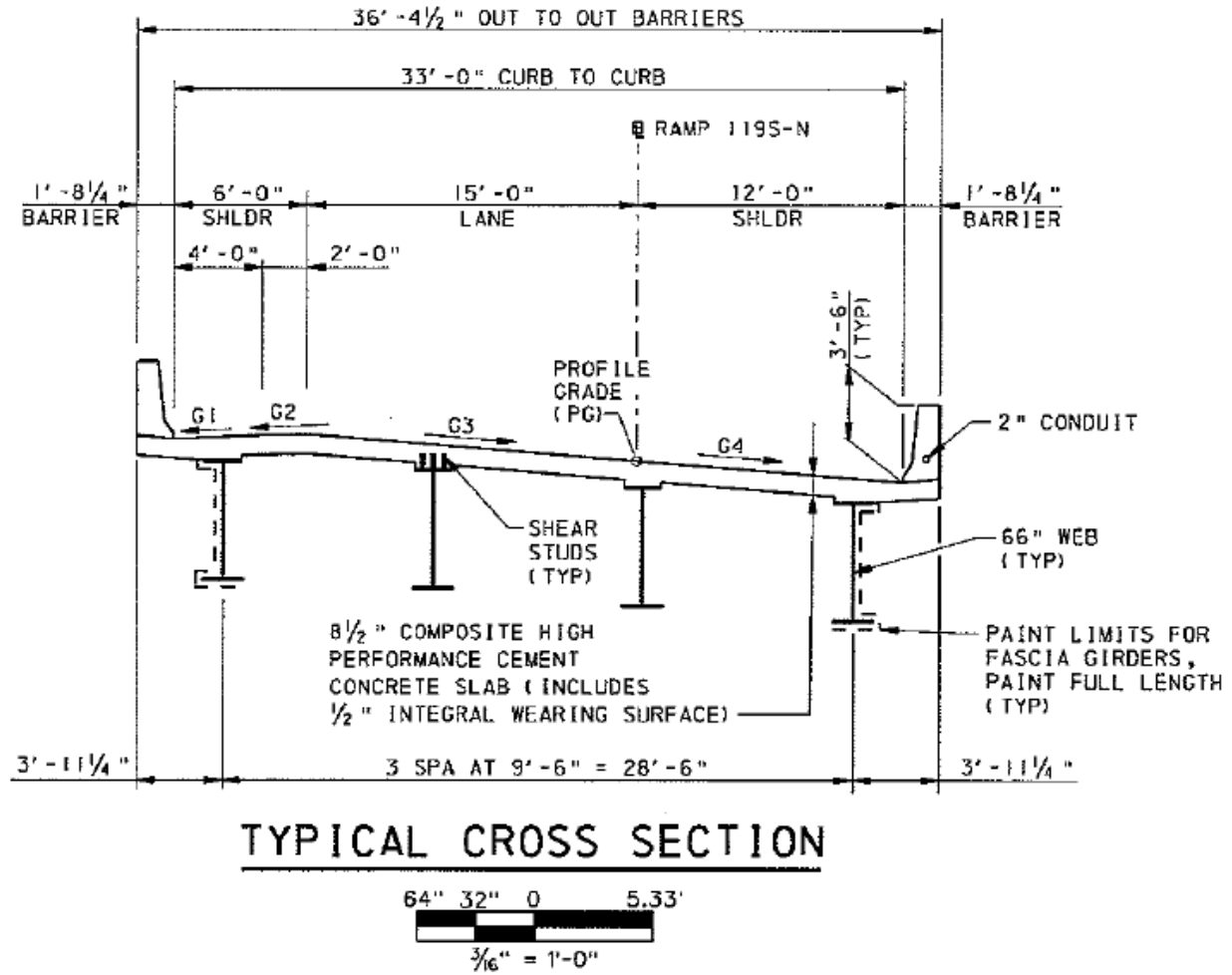

TABLE OF CROSS SLOPES				
STA	G1	G2	G3	G4
61+25.00	0.02	-0.02	0.08	0.08
63+72.14	0.02	-0.02	0.08	0.08
64+44.34	0.02	-0.02	0.06	0.06
65+16.54	0.02	0.02	0.04	0.04
65+88.73	0.04	0.04	0.02	0.04

**NOTE:**

POSITIVE CROSS SLOPE DIRECTIONS ARE SHOWN ON THE TYPICAL CROSS SECTION. NEGATIVE VALUES IN THE TABLE INDICATE THAT THE SLOPE IS IN THE OPPOSITE DIRECTION TO THAT SHOWN.

Figure 29 - Ramp 119 S-N Typical Cross Section

The ParamML code for one cross section is listed below. The sequence is repeated at each station where there is a change in any of the individual cross section segment slopes.

```

<O N="Sta_6125" T="CrossSection">
  <P N="Station" V="73500" UT="Length" UC="Layout" />
  <P N="LeftEdgeToHCL" V="272.25" UT="Length" UC="Layout" />
  <P N="ElevationAtHCL" V="0" UT="Length" UC="Layout" />
  <O N="Left Barrier" T="CrossSectionSegment">
    <P N="Slope" V="-0.09876543" />
    <P N="Width" V="20.25" UT="Length" UC="Layout" />
  </O>
  <O N="Left Shoulder" T="CrossSectionSegment">
    <P N="Slope" V="0.02" />
    <P N="Width" V="48" UT="Length" UC="Layout" />
  </O>
  <O N="Left Shy" T="CrossSectionSegment">
    <P N="Slope" V="-0.02" />
    <P N="Width" V="24" UT="Length" UC="Layout" />
  </O>
  <O N="Lane" T="CrossSectionSegment">
    <P N="Slope" V="-0.08" />
    <P N="Width" V="180" UT="Length" UC="Layout" />
  </O>
  <O N="Right Shoulder" T="CrossSectionSegment">
    <P N="Slope" V="-0.08" />
    <P N="Width" V="144" UT="Length" UC="Layout" />
  </O>
  <O N="Right Barrier" T="CrossSectionSegment">
    <P N="Slope" V="0.09876543" />
    <P N="Width" V="20.25" UT="Length" UC="Layout" />
  </O>
</O>

```

Figure 30 shows the five cross sections defining the variation in cross slopes. The figure was created by removing the horizontal curve from the alignment and creating a full width transverse line at each variation. This shows the change from an 8% cross slope in the travel lane at the beginning of the bridge to a 2% cross slope at the end of the bridge.

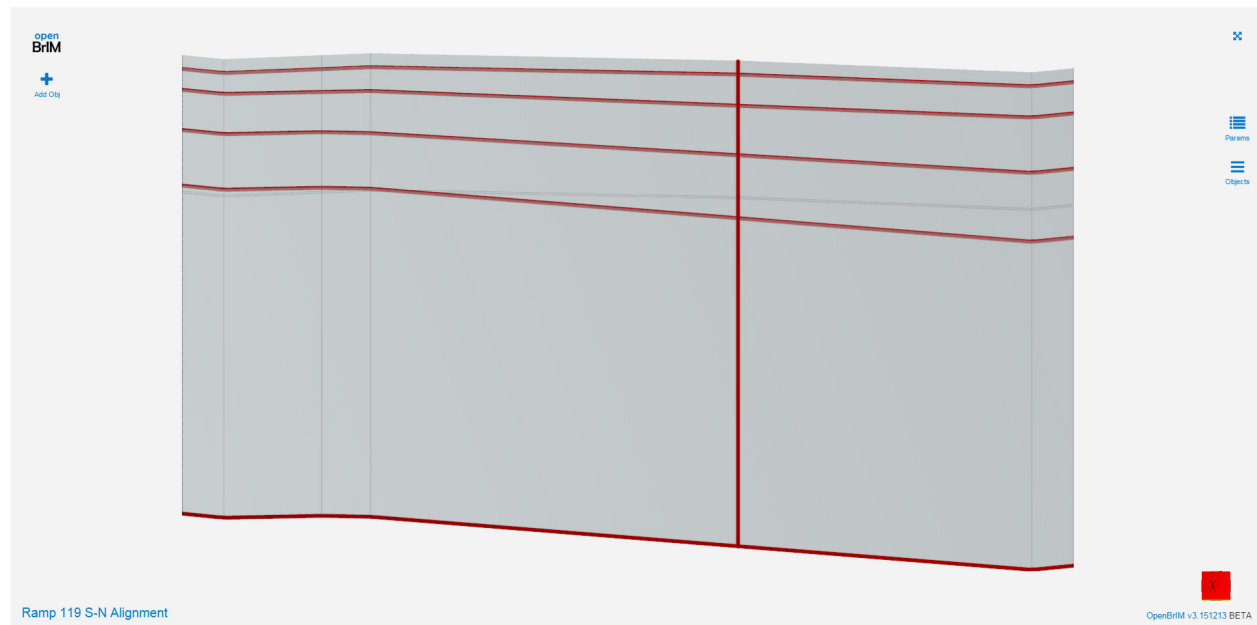

Figure 30 - Ramp 119 S-N Cross Slope Variation in OpenBrIM

#### 5.4.4 Alignment Functions

Once the alignment is fully defined, project can be set up to position objects on the alignment. If a graphical object is located on the bridge alignment, it needs to have an Alignment parameter with the name of the alignment as the value. Multiple alignments can be attached to a project. When developing library objects it is often convenient to switch back and forth between alignments to test how the object behaves in varying conditions.

There are three parameters used to define how an object is positioned and oriented.

- **AlignH:** allows control of the horizontal curve of the alignment on the object
- **AlignV:** allows control of the vertical curve of the alignment on the object
- **AlignT:** allows control of the transverse slope effect of the alignment on the object

Each of these parameters have three possible values.

- **None:** The object will be moved to its location on the alignment but it will not align (rotate) to the alignment.
- **Orient:** The object will be moved to its location on the alignment and it will rotate to match the heading.
- **Warp:** The object will be moved to its location on the alignment. It will not only rotate but also warp to match the horizontal, vertical, or cross section alignment.

Based on the type of type graphic primitive used (line, surface, or volume), many different alignment and orientation configurations can be modeled. In general, alignment parameters are used in the OpenBrIM project, not in the library app. However, there are exceptions to that rule. Examples of how these parameters are used will be addressed in Section 6.4

There are also two alignment features that can be used in library objects to handle some of the more complex geometry. The first feature includes several functions that are used to obtain global geometric information at a particular alignment station and offset. This information can be used to adjust the placement of an object.



- `alignHX(Alignment, station, tOff)` – Given an alignment, station and transverse offset, this returns the global X coordinate of a point.
- `alignHY(Alignment, station, tOff)` – Given an alignment, station and transverse offset, this returns the global Y coordinate of a point.
- `alignT(Alignment, station, tOff)` – Given an alignment, station and transverse offset, this returns the vertical distance from the alignment control line due to cross-slope adjustment.
- `alignTA(Alignment, station, tOff)` – Given an alignment, station and transverse offset, this returns the angle of the slope (in radians) above that point.
- `alignV(Alignment, station)` – Given an alignment and station, this returns vertical distance from the alignment control line due to vertical profile adjustment.

The second feature is meant for disregarding alignment cross-section adjustment of portions of an object such as a section or surface. There may be instances where the top of an object is intended to conform fully to the roadway vertical and cross slope alignment, but the bottom of the object is intended to be level or straight. In the definition of the surface or section, the parameter, `AlignTB="0"` is added to the point definition of any two or more points that are desired to be straight. An abutment backwall, and the buildup over girders in a deck are instances where this feature may be used.

The `alignT()` function and the `AlignTB` parameter were the only ones used during the development of this project, and both will be explained in Section 5.6 in the descriptions of the component library objects.

## 5.5 Developed Component Library Objects

One of the project scope objectives was to develop standard bridge component objects to evaluate the viability of the OpenBrIM concept. Most of the objects created by the project team were selected to model the Ramp 119 S-N. Approximately 30 separate library objects were created in the following major component categories (see Table 1):

- Abutments
- Piers
- Bearings
- Concrete Girders
- Steel Girders & Framing
- Decks
- Bridge Railings
- Miscellaneous

Reinforcing steel was not included as part of the overall bridge model, as the method to create reinforcing bar bends in the OpenBrIM Library and App was not developed in time. Straight reinforcing bars are constructed using the Line object and extruding a Circle object cross section between two points. A bent bar requires the extrusion to follow a series of straight and sharply curved line segments similar to a bridge alignment. In September 2015, a new Parameter, Polyline="1" was introduced for a Line object that enabled this capability. A single generic bar bend library object was developed from which any special bar bends can be accommodated.

In addition to the three CH2M project team members, OpenBrIM Library has five other active participants who have developed component objects. Those objects are not described in detail in this report, however they include several types of bridge railings, bearings, abutments and pier configurations. Recently a few library objects were developed for steel reinforcing bar bending patterns.

OpenBrIM Library objects are constructed to the following basic principles:

- Each object has an origin or reference insertion point, which is generally (X="0", Y="0", Z="0"). This point defines where the object will be positioned in a project with respect to the bridge alignment (i.e., station, offset, and elevation), and how it will be oriented (i.e., skew, plumb, parallel to cross slope, etc.).
- An internal unit set is used to define properties of the library objects. Default units are INCH for Length, RADIANS for Angle, FAHRENHEIT for Temperature, and KIPS for Force.
- Input parameters used to describe the object are assigned the attribute Role="Input", and for convenience can be assigned a group name using the attribute Category=" ".
- Objects should include documentation of dimensions placed on the 3D object view or in CADD views created by the author.

Many of the names used for library objects include initials of the author. User's libraries cannot be edited, so when collaborating, the objects have to be copied into other user's folders for review and editing. Each library object has to have a unique name, so adding author's initials became one way of handling it. Since project models reference the library objects many times, the names were left with the initials.

Table 1 - Component Library Objects

Major Component Categories	Sub-Component	Library Object Name
Abutments	Steel H-Pile	Pile (BB)
	U-Shaped Footing	Abutment U-Shaped Footing
	Stem Wall	Stem Abutment (BB)
	Backwall	Abutment Backwall 2
	Wingwall	Wingwall (BB)
	Cheekwall	Cheekwall
	Bearing Pedestal	ConcPedestal (BB)
Piers	Drilled Shaft	DrilledShaft
	Rectangular Footing	Rectangular Footing
	Rectangular Column	Rectangular Column
	Hammerhead Cap	Hammerhead Pier Cap (BB)
	Bearing Pedestal	ConcPedestal (BB)
Bearings	Pot Bearing	Pot Bearing
Concrete Girders	Prestressed Concrete Bulb-T Girder	OregonBulbT
	Prestressed Concrete Adjacent Box Girder	Std Box Beam
Steel Girders & Framing	Steel I-Girder	SteelGirderMB
	Vertical Stiffener/ Connection	VerticalStiffener
	Bolted Field Splice	BoltedFieldSplice (BB)
	Bolted Splice Plate	SplicePlate
	Bolt	Bolt (BB)
	Bolt Group	BoltGroup (BB)
	Shear Stud	Shear Stud
	Shear Stud Placement	Stud Placement
	Cross Frame Type K	CrossFrameTypeKTop
	Bolted Gusset	BoltedGusset
	Welded Gusset	WeldedGusset
	Cross Frame Layout	CrossFrameLayout
	Plate Diaphragm	Diaphragm
Deck	Deck	Deck
	Deck End Beam	DeckEndBeam
Bridge Railings	Traffic Barrier	PA Turnpike Barrier New
Miscellaneous	Generic Reinforcing Bar Bend	BentRebar

Sections that follow describe some of the individual library component objects by major component categories. The more complex objects will be described in detail. Full documentation on each library object can be found in Appendix A.

### 5.5.1 Abutments

Bridge abutments are configured in many different ways. The most common types are full-height, stub, spill-through, and integral. Because of this, developing a generic parametric abutment object would be difficult. Typically an abutment is comprised of sub-components, such as piles, footings, a stem wall for support of the superstructure, a backwall and wingwalls to retain the embankment, bearing pedestals, and cheek walls to hide and protect the bridge bearings. Figure 31 shows the full height abutment of Ramp 119 S-N and the different component library objects that can be used to define it. Those objects will be described in more detail below. The assembly into a bridge model will be detailed in Section 6.

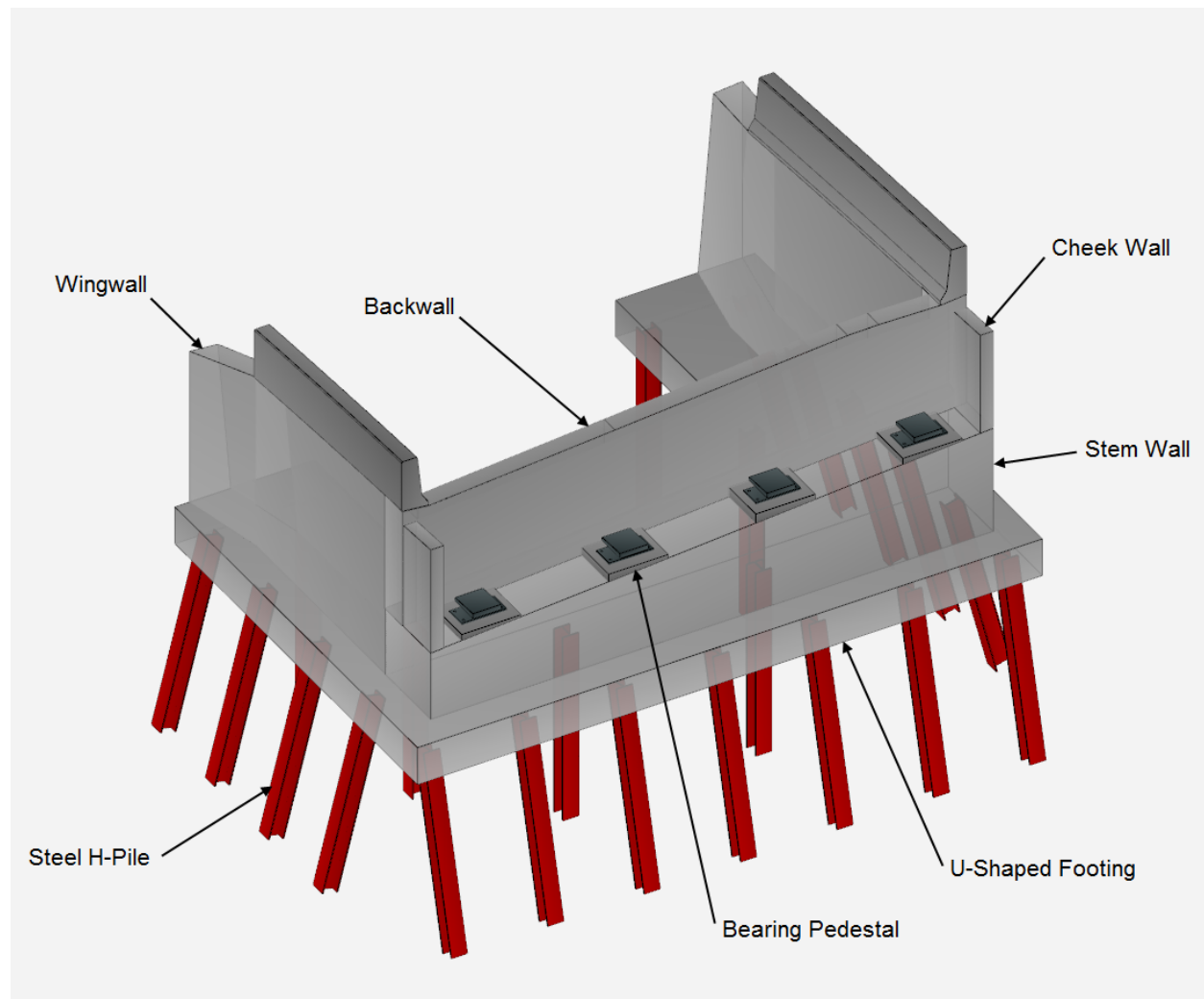

Figure 31 - Ramp 119 S-N Abutment 1

#### 5.5.1.1 Steel H-Pile

The Pile (BB) object is used for the steel H-Piles, which are generally defined as a Volume object by extruding a Section object between two Point objects. H-Piles can be battered with respect to the vertical axis, and while the direction of batter is most often parallel to either the longitudinal or transverse pier or abutment axis, the batter can be at 45 degrees to either of those directions (see Figure 32). Therefore they are defined with a batter slope, and a batter direction. In addition, the cross

section can be battered in the direction of either the web or the flanges. Each of these angles is defined as an input parameter as shown in Figure 33.

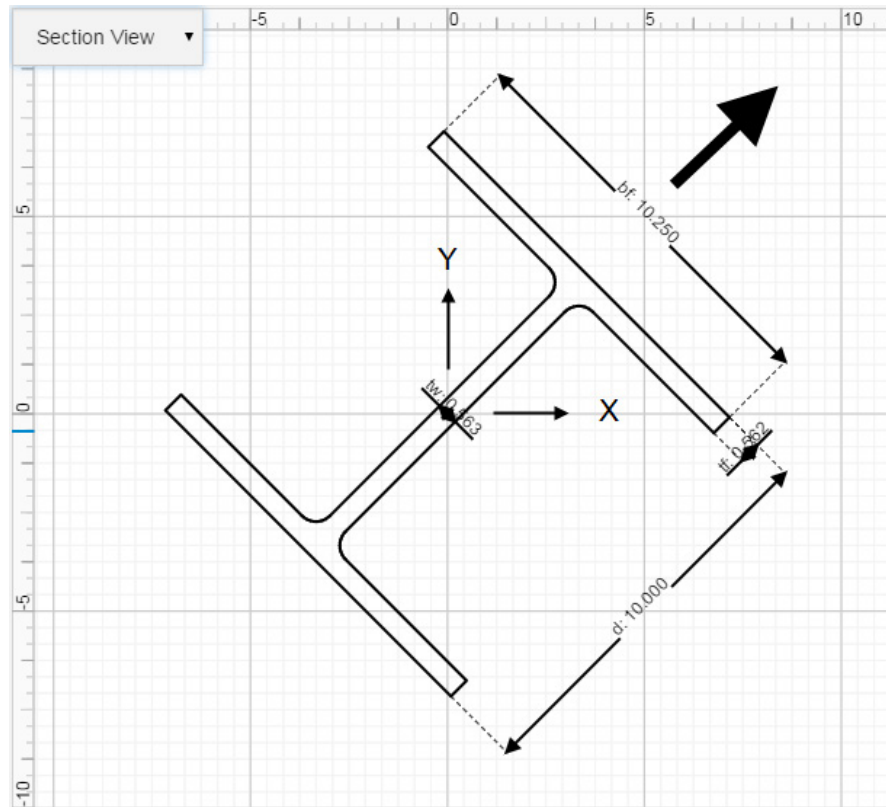

Figure 32 - H-Pile Batter Orientation, Phi Angle

Pile (BB)
BY BENJAMIN BLASEN

Params ▼

Refresh

<div style="border: 1px solid #ccc; padding: 2px; background-color: #f0f0f0; margin-bottom: 5px;">d Depth</div> <div style="border: 1px solid #ccc; padding: 5px; text-align: center; margin-bottom: 5px;">10</div>	<div style="border: 1px solid #ccc; padding: 2px; background-color: #f0f0f0; margin-bottom: 5px;">bf Flange width</div> <div style="border: 1px solid #ccc; padding: 5px; text-align: center; margin-bottom: 5px;">10.25</div>	<div style="border: 1px solid #ccc; padding: 2px; background-color: #f0f0f0; margin-bottom: 5px;">tf Flange Thickness</div> <div style="border: 1px solid #ccc; padding: 5px; text-align: center; margin-bottom: 5px;">0.5625</div>
<div style="border: 1px solid #ccc; padding: 2px; background-color: #f0f0f0; margin-bottom: 5px;">tw Web Thickness</div> <div style="border: 1px solid #ccc; padding: 5px; text-align: center; margin-bottom: 5px;">0.5625</div>	<div style="border: 1px solid #ccc; padding: 2px; background-color: #f0f0f0; margin-bottom: 5px;">fillet Fillet Radius</div> <div style="border: 1px solid #ccc; padding: 5px; text-align: center; margin-bottom: 5px;">0.5</div>	<div style="border: 1px solid #ccc; padding: 2px; background-color: #f0f0f0; margin-bottom: 5px;">L Length</div> <div style="border: 1px solid #ccc; padding: 5px; text-align: center; margin-bottom: 5px;">300</div>
<div style="border: 1px solid #ccc; padding: 2px; background-color: #f0f0f0; margin-bottom: 5px;">Batter Slope H v</div> <div style="border: 1px solid #ccc; padding: 5px; text-align: center; margin-bottom: 5px;"><math>\frac{3}{12} = 0.25</math></div>	<div style="border: 1px solid #ccc; padding: 2px; background-color: #f0f0f0; margin-bottom: 5px;">Phi Batter Orientation</div> <div style="border: 1px solid #ccc; padding: 5px; text-align: center; margin-bottom: 5px;"><math>\frac{\text{PI}}{4} = 0.7854</math></div>	<div style="border: 1px solid #ccc; padding: 2px; background-color: #f0f0f0; margin-bottom: 5px;">Beta Web Orientation</div> <div style="border: 1px solid #ccc; padding: 5px; text-align: center; margin-bottom: 5px;">0</div>

Figure 33 - Pile Parameters

### 5.5.1.2 U-Shaped Footing

A U-shape is common for an abutment footing for support of the stem wall and wingwalls. This is a simple object that requires ten parameters to completely describe as shown in Figure 34 and Figure 35.

open  
BrIM **Abutment U-Shaped Footing** BY MIKE BARTHOLOMEW

Refresh

Params ▾

Length Footing Length (Transverse to Bridge Alignment)	484.5	Width Footing Width (Along Bridge Alignment)	108	WWA_Length Footing Length (Transverse to Bridge Alignment)	384
WWA_Width Footing Width (Along Bridge Alignment)	108	WWB_Length Footing Length (Transverse to Bridge Alignment)	324	WWB_Width Footing Width (Along Bridge Alignment)	108
Depth Footing Depth	30	BotElev Footing Bottom Elevation	0	CL_Bearing CL Bearing to Front Edge of Footing	42
HCL_Offset HCL to Left Edge of Footing	188.25				

Figure 34 - Abutment U-Shaped Footing Parameters

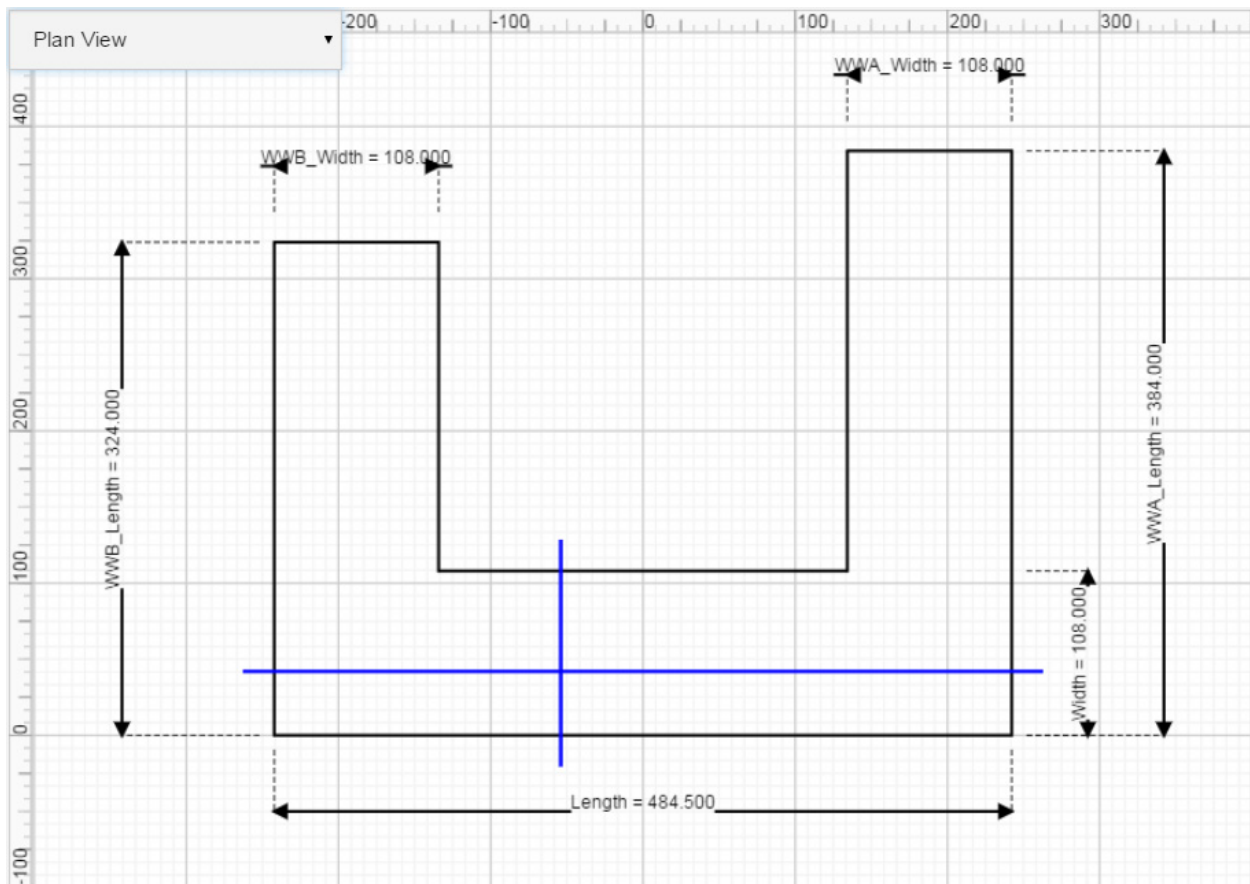

Figure 35 - Abutment U-Shaped Footing Graphical Representation of Parameters

The parametric data needed in the library object is as follows:

```
<O N="Abutment U-Shaped Footing" T="Project">
  <P N="Length" V="484.5" D="Footing Length (Transverse to Bridge Alignment)" Role="Input" />
  <P N="Width" V="108" D="Footing Width (Along Bridge Alignment)" Role="Input" />
```

```

<P N="WWA_Length" V="384" D="Footing Length (Transverse to Bridge Alignment)" Role="Input" />
<P N="WWA_Width" V="108" D="Footing Width (Along Bridge Alignment)" Role="Input" />
<P N="WWB_Length" V="324" D="Footing Length (Transverse to Bridge Alignment)" Role="Input" />
<P N="WWB_Width" V="108" D="Footing Width (Along Bridge Alignment)" Role="Input" />
<P N="Depth" V="30" D="Footing Depth" Role="Input" />
<P N="BotElev" V="0" D="Footing Bottom Elevation" Role="Input" />
<P N="CL_Bearing" V="42" D="CL Bearing to Front Edge of Footing" Role="Input" />
<P N="HCL_Offset" V="188.25" D="HCL to Left Edge of Footing" Role="Input" />
.
.
.

```

The same lines of code above are used in the project file, however any of the data values can be changed to achieve different sized footings. A surface object with thickness is used to create the graphical view of the footing. The surface is comprised of point objects defining the perimeter of the footing. ParamML code required to develop the object is as follows:

```

<O T="Surface" Z="BotElev">
  <P N="Thickness" V="Depth" />
  <O T="Point" X="-HCL_Offset" Y="-CL_Bearing" />
  <O T="Point" X="Length-HCL_Offset" Y="-CL_Bearing" />
  <O T="Point" X="Length-HCL_Offset" Y="WWA_Length-CL_Bearing" />
  <O T="Point" X="Length-HCL_Offset-WWA_Width" Y="WWA_Length-CL_Bearing" />
  <O T="Point" X="Length-HCL_Offset-WWA_Width" Y="Width-CL_Bearing" />
  <O T="Point" X="-HCL_Offset+WWB_Width" Y="Width-CL_Bearing" />
  <O T="Point" X="-HCL_Offset+WWB_Width" Y="WWB_Length-CL_Bearing" />
  <O T="Point" X="-HCL_Offset" Y="WWB_Length-CL_Bearing" />
</O>

```

Additional code is required to create the CADD view with dimensioning. Those views are primarily to help with visualization of the object for documentation purposes.

### 5.5.1.3 Stem Wall

The stem wall, named Stem Abutment (BB), is supported on an abutment footing and provides support for the bridge superstructure and the backwall. The bottom of the stem wall is level to match the footing, however the top may be either level or sloped. Input parameters required for definition are the length, width, and height of the stem at the centerline, and the transverse slope of the top support. The slope is used to compute the stem wall heights at each end. The object is developed as a Volume by extruding two rectangular Surface objects between the transverse limits of the abutment length. The stem wall incorporates the bearing pedestal library object ConcPedestal (BB).

### 5.5.1.4 Backwall

The Abutment Backwall library object is meant to be placed on top of Stem Abutment (BB) object. This object has the option of a blockout for support of an approach panel. The blockout can extend full width of the backwall, or it can be limited on either end by a left stub and right stub. The graphic construct is a Volume object extruded longitudinally along the bridge alignment from Surface objects corresponding to the back face and front face of the backwall and two at the pavement seat.

A unique feature provided with the Backwall object is the ability to have its top surface match the varying roadway cross slope, and the bottom surface remain constant to match the Stem Wall. Ignoring for the moment, the additional definition needed for the pavement seat blockout, the library Volume object could be defined with only two end surfaces each with four corner points as shown in Figure 36. However, in the project, if the Abutment Backwall object is defined with the AlignT="Warp" parameter,

it will force the top of the backwall to conform to the transverse cross section alignment profile. By defining only the two bottom points for each surface, and assigning the AlignTB="0" attribute to them, the bottom will be straight as shown in Figure 37.

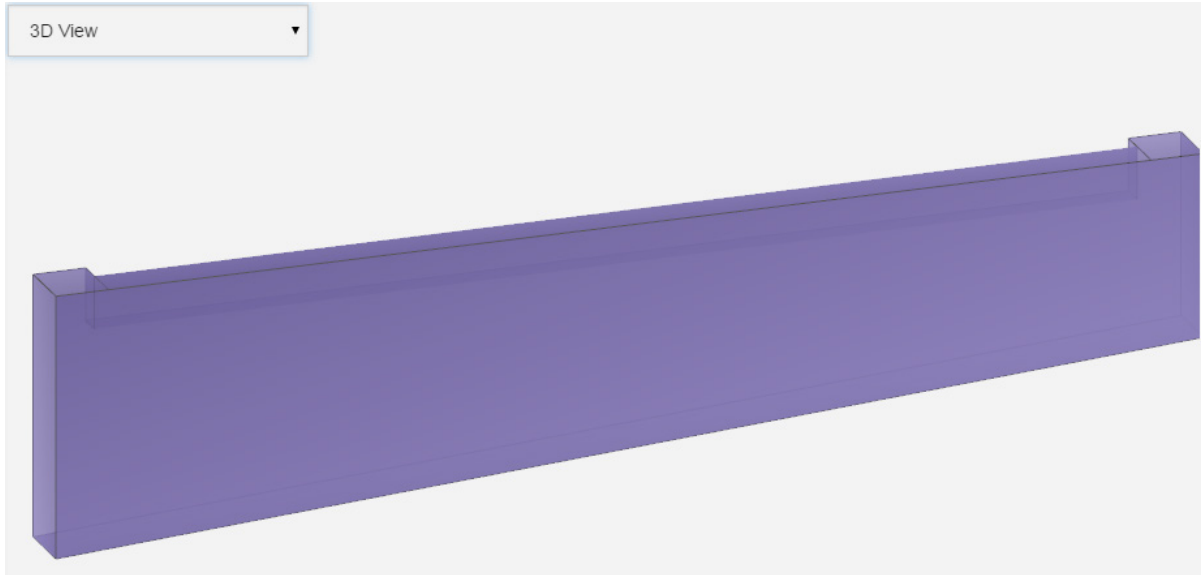

Figure 36 - Abutment Backwall Library Object

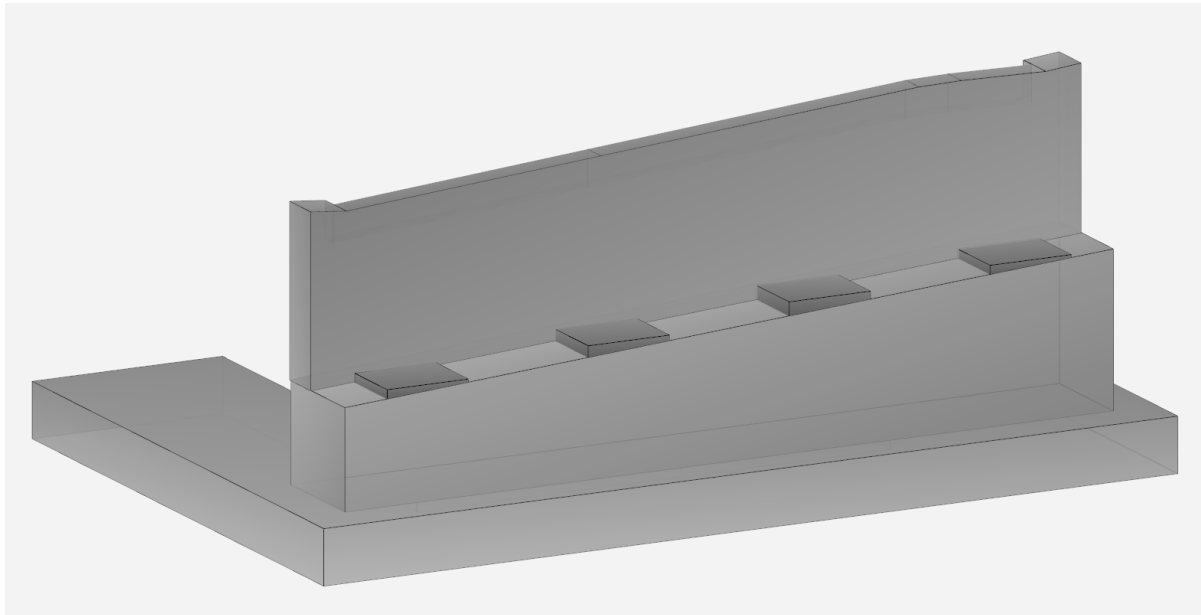

Figure 37 - Abutment Backwall in the Project

The ParamML code to do this for one surface object is as follows:

```
<O T="Volume" AlignH="Warp" AlignT="Warp">
  <O T="Surface" X="-StemWidth/2">
    <P N="SegmentsAround" V="1" />
    <P N="SegmentsAlong" V="1" />
    <O T="Point" X="0" Z="PedSlope*AbutLength/2-ADJLF" Y="-AbutLength/2" AlignTB="0" />
    <O T="Point" X="0" Z="BackWallHeight" Y="-AbutLength/2">
    <O T="Point" X="0" Z="BackWallHeight" Y="AbutLength/2">
    <O T="Point" X="0" Z="-PedSlope*AbutLength/2-ADJRF" Y="AbutLength/2" AlignTB="0" />
```



</O>

#### 5.5.1.5 Wingwall

Wingwall objects are typically placed on top of Footing objects. The walls are often tapered so that the thicker section is at the footing level. The top of the wall can follow the bridge vertical profile, while the bottom is level.

#### 5.5.1.6 Cheekwall

The Cheekwall library object is meant to be placed on top of Stem Abutment (BB) library object. This object is placed outside of the girders on the edge of the abutment as a visual cover and protection of the bearing connection. The top of the cheekwall has the option to slope using the "TopSlope" parameter. The bottom of the cheekwall has the option to follow a stem pedestal slope using the "PedSlope" parameter.

#### 5.5.1.7 Bearing Pedestal

The ConcPedestal (BB) library object is for providing level bearing seats on top of the Stem Abutment (BB) or Hammerhead Pier Cap (BB) library objects. If the support abutment or pier cap seat is sloped, the thickness of the pedestal is variable. The top and bottom widths can also vary.

The Wingwall, Cheekwall, and Bearing Pedestal objects are all relatively simple objects and are shown in Figure 31.

## 5.5.2 Piers

Piers, like abutments, can take on many configurations and developing a generic parametric pier object would also be difficult. The most common types of piers are multiple column drop cap, hammerhead, pile bents, etc. Typically piers are comprised of sub-components, such as piles or drilled shafts, footings, columns, and a pier cap and bearing pedestals. Figure 38 shows piers for Ramp 119 S-N and the typical components that have been turned into library objects.

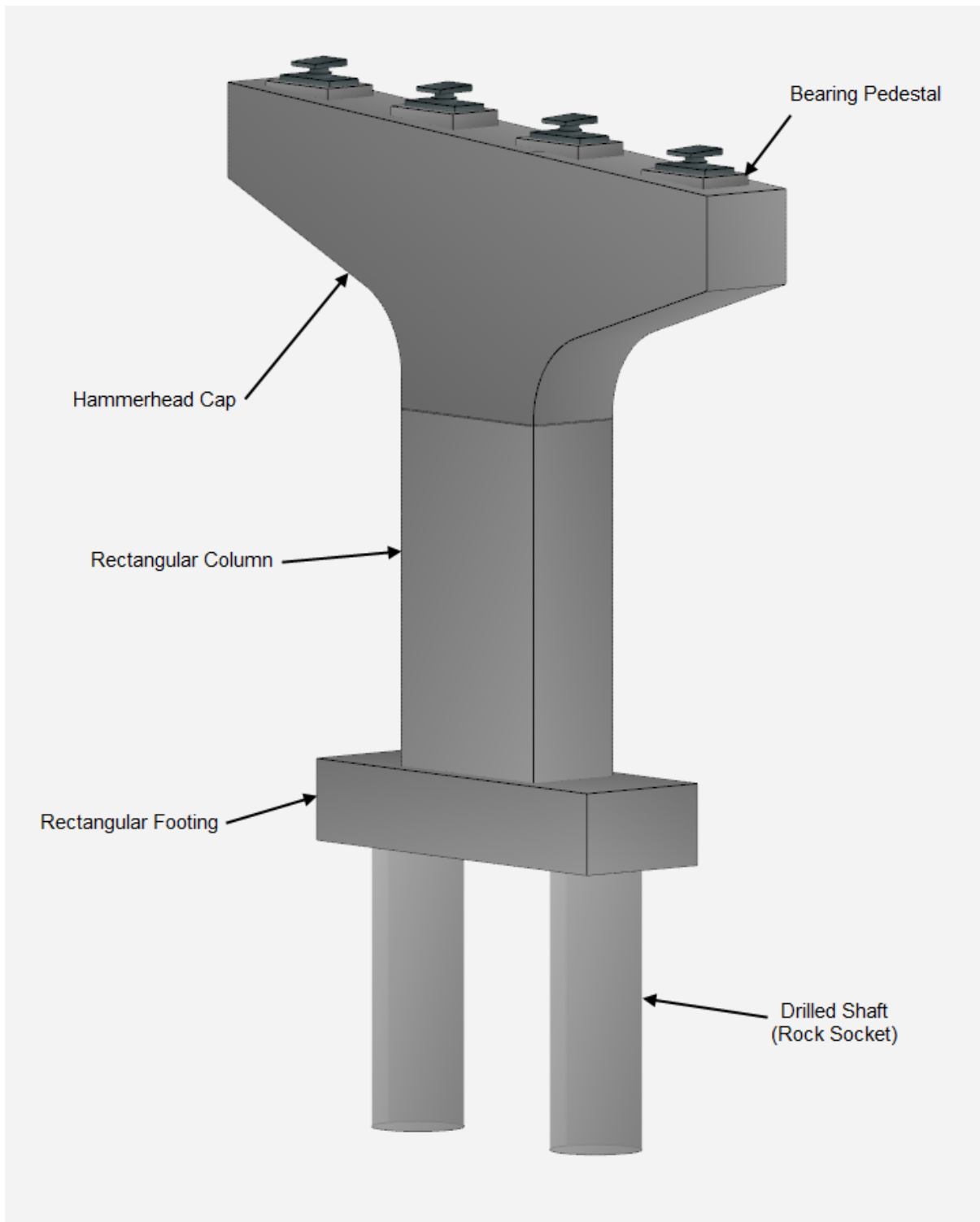

Figure 38 - Ramp 119 S-N Hammerhead Pier

#### 5.5.2.1 Drilled Shaft

The DrilledShaft library object is constructed as a Volume object using a Circle object extruded between two Point objects, similar to a Line object. The reference insertion point is at the center of the top of the shaft. The only parameters necessary are the diameter of the shaft and its length.

### 5.5.2.2 Rectangular Footing

The Rectangular Footing library object is constructed as a Surface object with a thickness. Its reference insertion point is at the bottom of the footing.

### 5.5.2.3 Rectangular Column

The Rectangular Column object is also constructed as a Volume object, but using a Section object extruded between Point objects. Its reference insertion point is at the top of the footing.

### 5.5.2.4 Hammerhead Cap

The Hammerhead Cap connects to the Rectangular Column and is constructed as a Surface object with a thickness. The surface is in the Y-Z plane, and is comprised of nine perimeter points. The width of the cap is the thickness parameter. The top surface of the cap can be crowned as shown in Figure 39.

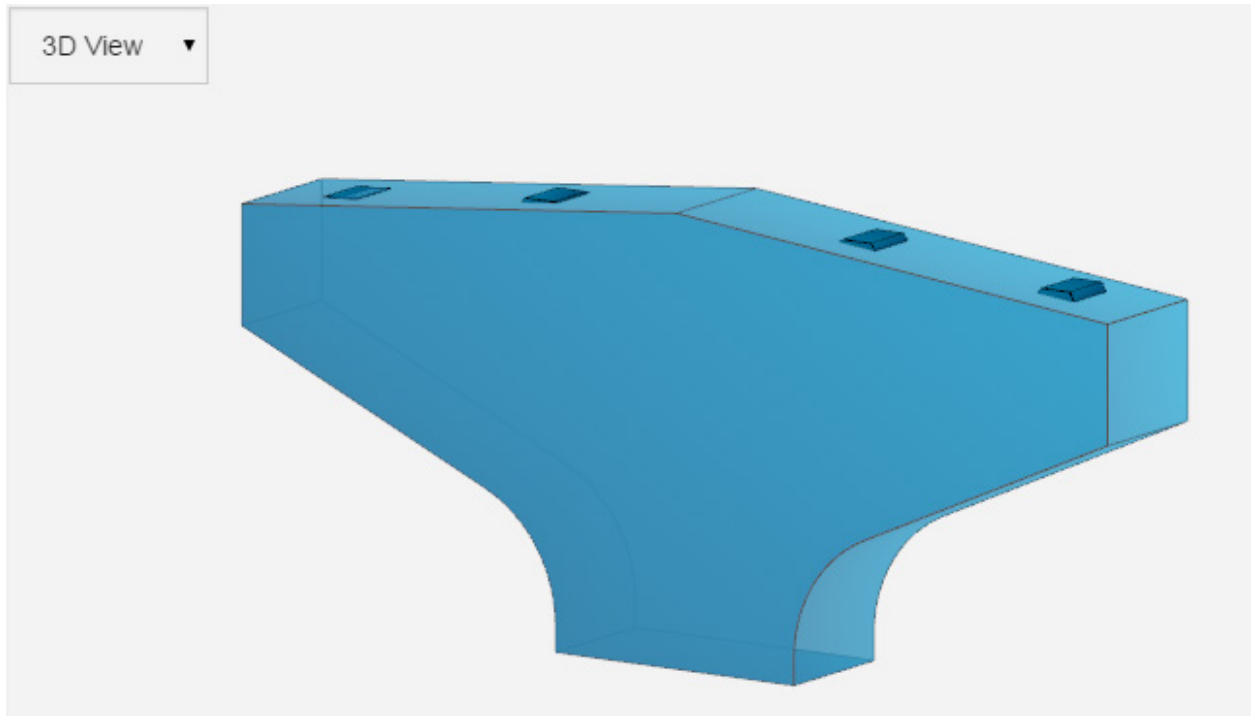

Figure 39 - Hammerhead Pier Cap with Crown

The intersecting points connecting the Rectangular Column to the cantilever arms of the cap have a large radius fillet. Any interior corner point on a Surface or Section object can be assigned a parameter to denote that the intersection is formed by a fillet radius or a straight chamfer. The following highlighted ParmML code exhibits how a fillet radius is made. In addition to having X, Y, and Z coordinates, a Point object can also have the expression  $R=60$  to denote that radius is to be applied.

```
<O T="Surface" X="PierWidth/2">
  <P N="Thickness" V="PierWidth" />
  <O T="Point" Z="(PierLength/2-DistanceToCrown)*PCrossSlopeL" Y="-PierLength/2" />
  <O T="Point" Z="0" Y="-DistanceToCrown" />
  <O T="Point" Z="(PierLength/2+DistanceToCrown)*PCrossSlopeR" Y="PierLength/2" />
  <O T="Point" Z="(PierLength/2+DistanceToCrown)*PCrossSlopeR-MinD_R" Y="PierLength/2" />
  <O T="Point" Z="(PierLength/2+DistanceToCrown)*PCrossSlopeR-MaxD_R" Y="PierLength/2-
ExtensionR" R="ColumnRadius" />
```

```

<O T="Point" Z="(PierLength/2+DistanceToCrown)*PCrossSlopeR-MaxD_R-ColumnExt"
Y="PierLength/2-ExtensionR" />
<O T="Point" Z="(PierLength/2+DistanceToCrown)*PCrossSlopeR-MaxD_R-ColumnExt" Y="-
PierLength/2+ExtensionL" />
<O T="Point" Z="(PierLength/2-DistanceToCrown)*PCrossSlopeL-MaxD_L" Y="-
PierLength/2+ExtensionL" R="ColumnRadius" />
<O T="Point" Z="(PierLength/2-DistanceToCrown)*PCrossSlopeL-MinD_L" Y="-PierLength/2" />
</O>

```

## 5.5.3 Bearings

### 5.5.3.1 Pot Bearing

Pot Bearing is a schematic representation of a bearing system with masonry base plate, pot & piston, and a top sole plate. The masonry plate is a rectangle with four anchor bolts in the corners, and the pot and piston are cylinders, all constructed as Surface objects with thicknesses. The top sole plate has a tapered thickness to account for the vertical grade of the girders, and is constructed as a Volume object. The average sole plate thickness is an input parameter, and the tapered dimensions are developed by OpenBrIM based on the vertical grade at the bearing location. The 3-D representation is shown in Figure 40.

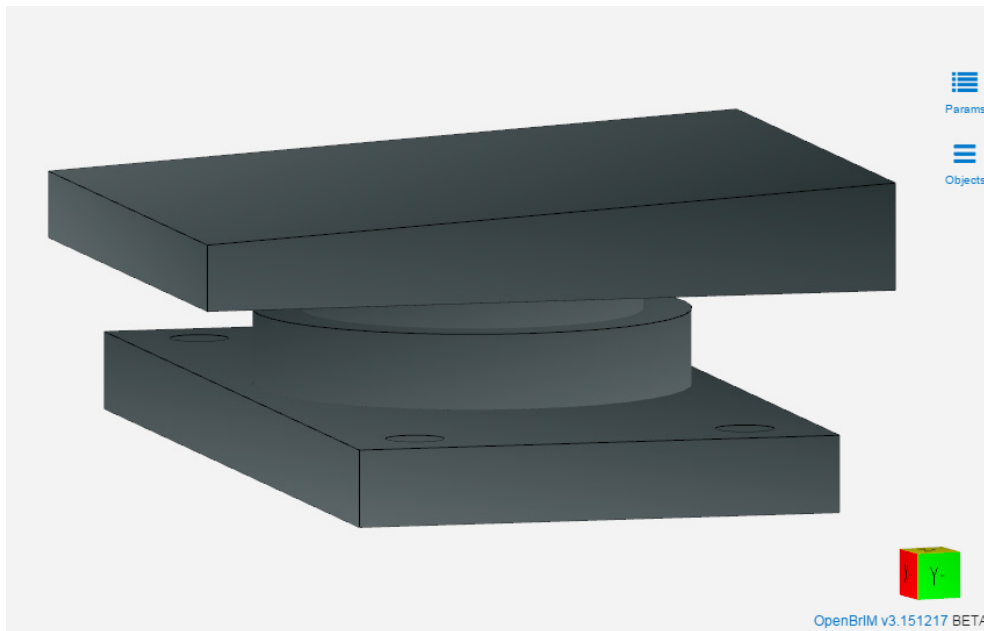

Figure 40 - Pot Bearing

## 5.5.4 Concrete Girders

### 5.5.4.1 Prestressed Concrete Bulb-T Girder

The OregonBulbT library object is based on the Oregon DOT standard for precast prestressed concrete girders. The bottom bulb of the girders is always normal to the longitudinal axis, however for skewed alignments, the top flange follows the skew of the pier. The girder is constructed as a Section object extruded between end points. To accommodate the skew on the top flange, two different cross sections are used, on three different Line objects.

#### 5.5.4.2 Prestressed Concrete Adjacent Box Girder

The Std Box Beam (BB) library object is based on New York State DOT standard for adjacent box beams. Beams are hollow and have intermediate and end diaphragms.

Limitations:

- 1) Girders must be straight.
- 2) Girders must have the same skew at beginning and end.
- 3) Alignment may contain curves, however the piers must be parallel.
- 4) There must be a least one interior diaphragm.

## 5.5.5 Steel Girders

### 5.5.5.1 Steel I-Girder

SteelGirderMB object is used for creating Bridge Steel Plate I-Girders. Girders can be defined as a single object for the entire length of the bridge, or as individual field sections. The cross section is comprised of a web and top and bottom flange plates. The widths and thicknesses of the plates can vary in steps along the length of the girder as shown in Figure 41.

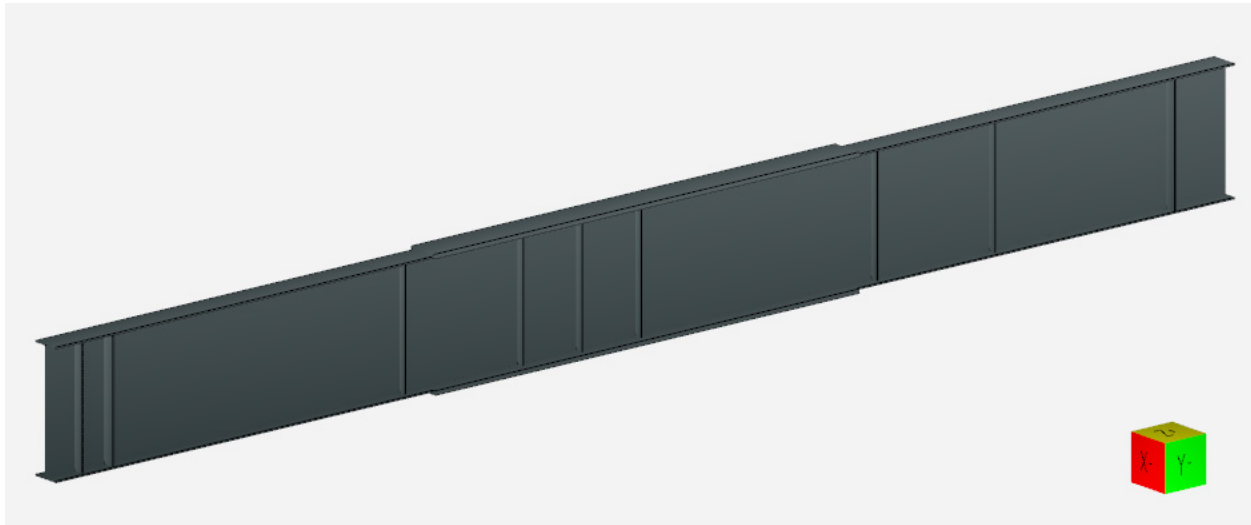

Figure 41 - Steel I-Girder

The parameters defining the cross section include the web depth (dw) and thickness (tw), the top flange width (bft) and thickness (tft), and the bottom flange width (bfb) and thickness (tfb) are seen in the data entry screen (see Figure 42). The array of numbers for the flanges are range variables and further explained below. Only Line objects can utilize this feature.

SteelGirderMB by Mike Bartholomew

Girder Cross Section Data ▾

Refresh
Length Length of Field Section

1000

dw Web depth of the I girder

90

tw Web thickness of the I girder

0.75

tfb Thickness of the bottom flange of the I girder

[0, 320, 1, 320, 680, 3, 680, 1000, 1]

bft Width of the top flange of the I girder

[0, 320, 20, 320, 680, 24, 680, 1000, 20]

tft Thickness of the top flange of the I girder

[0, 320, 1, 320, 680, 3, 680, 1000, 1]

bfb Width of the bottom flange of the I girder

[0, 320, 20, 320, 680, 24, 680, 1000, 20]

Figure 42 - Steel I-Girder Section Data

For the thickness of the top flange, the data shown in Figure 43 uses the following double bracket expression for the range variable tft, `[[0, 600], 1, [600, 1000], 3]`. This means that from 0 to 600 inches along the girder, the top flange is 1" thick, and from 600 to 1000 inches, it is 3" thick. This nomenclature allows any number of plate size changes within a single girder field section. For every thickness, there needs to be a bracketed range preceding it. Once a range variable is set up in the library object, any number of parameters can be referenced from the project. A single value results in a constant dimension for the entire object. To account for five plate changes, will require five non overlapping ranges and five values. Any type of step variation can be specified.

Thickness of the top flange of the I girder (tft) x

[[0, 320], 1, [320, 680], 3, [680, 1000], 1]

[[0, 320], 1, [320, 680], 3, [680, 1000], 1] = 0,320,1,320,680,3,680,1000,1

Cancel OK

Figure 43 - Top Flange Range Variable Data

The girder also includes provisions for various types of vertical stiffeners, including shear stiffeners, cross frame connection plates, bearing stiffeners at supports, and jacking stiffeners near supports for future bearing replacement. Figure 44 shows the parameters needed to define shear stiffeners. Cross frame connection plates, as well as bearing and jacking stiffeners are defined similarly. Stiffener dimensional parameters are passed through the SteelGirderMB object to the Vertical Stiffener object described in the next sub-section. The parameter WebStiffOrient determines which side of the web the stiffener is located, by the values L, R, B, or N, for left, right, both, or none. By selecting N, the stiffener dimensional data can be left out. The WebStiffLoc parameter locates the stiffener along the length of the girder section.

open BrIM SteelGirderMB by Mike Bartholomew

Refresh ShearStiffener ▾

WebStiffOrient Side of Web stiffened, L = Left, R = Right, B = Both N = None R	WebStiffT Shear Stiffener Thickness 0.25	WebStiffW Shear Stiffener Width 6
WebStiffHeight Shear Stiffener Height 90	WebStiffClipH Shear Stiffener Horizontal Clip 1.5	WebStiffClipV Shear Stiffener Vertical Clip 2.5
WebStiffLoc Shear Stiffener locations [300, 400, 500, 700, 800]		

Figure 44 - Shear Stiffener Location Data

The following excerpt is from the ParamML code for the object. Point, Shape, Section, and Line objects are used to draw the basic girder. The girder parameters tft, bft, dw, tw, tfb, and bfb are used to develop the Point objects to create individual flange and web Shape objects that are then combined into a Section object. The hierarchy of the different objects can be seen in the indentation of the code lines. A Line object is used to extrude the Section between the defined end points of the girder.

```
<O N="GirderFieldSection" T="Group">
  <O N="IGirder" T="Section">
    <O N="Top Flange" T="Shape">
      <P N="Material" V="STEEL" T="Material" D="Material" />
      <O T="Point" Y="tft" X="-bft/2" />
      <O T="Point" Y="tft" X="bft/2" />
      <O T="Point" Y="0" X="bft/2" />
      <O T="Point" Y="0" X="-bft/2" />
    </O>
    <O N="Web" T="Shape">
      <P N="Material" V="STEEL" T="Material" D="Material" />
```



```

    <O T="Point" Y="0" X="tw/2" />
    <O T="Point" Y="-dw" X="tw/2" />
    <O T="Point" Y="-dw" X="-tw/2" />
    <O T="Point" Y="0" X="-tw/2" />
  </O>
  <O N="Bottom Flange" T="Shape">
    <P N="Material" V="STEEL" T="Material" D="Material" />
    <O T="Point" Y="-dw" X="bfb/2" />
    <O T="Point" Y="-dw-tfb" X="bfb/2" />
    <O T="Point" Y="-dw-tfb" X="-bfb/2" />
    <O T="Point" Y="-dw" X="-bfb/2" />
  </O>
</O>
<O T="Line">
  <P N="Section" V="IGirder" T="Section" />
  <O T="Point" Y="0" X="0" Z="0" />
  <O T="Point" Y="0" X="Length" Z="0" />
</O>
.
.
.
</O>

```

Vertical stiffeners are added to the girder from within the SteelGirderMB object. There are four different types of stiffeners that all use similar code. Only one is shown below. There are several new ParamML features that are introduced in this object's code - Guard, AlignH and AlignV parameters, Repeat object, and length and alignT functions

Guard is used to inactivate objects based on how other parameters are set. There are three different Guard parameters used in the code. All test the value of the parameter WebStiffOrient. If it is "None", then the rest of the code is skipped. The other tests are for "R" or "B" and "L" or "B" to see if the stiffeners should be placed on the right, left, or both sides of the web.

The Repeat object is used to generate multiple stiffeners and place them along the girder based on the array of values in the WebStiffLoc parameter. Repeat requires parameters "S" for start value, "E" for end value, "I" for increment, and "CTRL" for the variable that is incremented. In this case it is the index of the WebstiffLoc parameter array. The "E" value parameter is the length of the WebStiffLoc array.

When the VerticalStiffener object is referenced, the parameter, AlignH="Warp" is used to position the stiffener to follow any horizontal curves in the alignment, and the parameter AlignV="Orient" adjusts for the vertical grade. AlignT would be used when the object is expected to be placed normal to the cross slope. Since steel plate I-girders have their webs vertical, AlignT should be set to "None", which is the default setting, so it is not necessary to include it. Normally, the AlignH, AlignV, and AlignT parameters are not included in library objects. In this instance it is necessary to compensate for vertical cross-slope variation. When stiffeners are placed on only one side of the web, their centroid is offset from the centerline of the girder. All objects are positioned and oriented based on their station and offset on the project alignment. They are also adjusted for cross slope. Since the stiffener centroid does not coincide with the girder centroid, the stiffener will be positioned slightly higher or lower than the girder by the value of cross slope times the transverse difference in centroids. The alignT() function is used to compute the vertical elevations of the roadway at both the girder and stiffener offsets (Parameters CL, GR, and GL). The difference between the elevation at CL and GL or GR is then computed and used to adjust the vertical position of the stiffener so that it aligns properly with the girder. The intermediate parameters AdjR and AdjL are used as a correction to the stiffener vertical position Z.

```

<O N="Shear Stiffeners" T="Group">
  <P N="Guard" V="WebStiffOrient.NE.None" />
  <O T="Repeat">
    <P N="S" V="1" />
    <P N="E" V="length(WebStiffLoc)" />
    <P N="I" V="1" />
    <P N="CTRL" V="spi" T="Text" />
    <P N="spi" V="0" />
    <O N="Draw Right" T="Group">
      <P N="Guard" V="(WebStiffOrient.EQ.R).OR.(WebStiffOrient.EQ.B)" />
      <P N="CL" V="alignT(Alignment, StartStation+WebStiffLoc[spi-1], Offset)" />
      <P N="GR" V="alignT(Alignment, StartStation+WebStiffLoc[spi-1], Offset+tw/2+WebStiffW/2)"
    />
    <P N="AdjR" V="CL-GR" />
    <O T="VerticalStiffener" Y="tw/2" X="WebStiffLoc[spi-1]" Z="AdjR" AlignH="Warp"
  AlignV="Orient">
    <P N="t" V="WebStiffT" D="Thickness" />
    <P N="w" V="WebStiffW" D="Width" />
    <P N="h" V="WebStiffHeight" D="Height" />
    <P N="clipV" V="WebStiffClipV" D="Vertical clip height" />
    <P N="clipH" V="WebStiffClipH" D="Horizontal clip width" />
  </O>
</O>
  <O N="Draw Left" T="Group">
    <P N="Guard" V="(WebStiffOrient.EQ.L).OR.(WebStiffOrient.EQ.B)" />
    <P N="CL" V="alignT(Alignment, StartStation+WebStiffLoc[spi-1], Offset)" />
    <P N="GL" V="alignT(Alignment, StartStation+WebStiffLoc[spi-1], Offset-tw/2-WebStiffW/2)"
  />
  <P N="AdjL" V="CL-GL" />
  <O T="VerticalStiffener" Y="-tw/2" X="WebStiffLoc[spi-1]" Z="AdjL" RZ="PI" AlignH="Warp"
AlignV="Orient">
  <P N="t" V="WebStiffT" D="Thickness" />
  <P N="w" V="WebStiffW" D="Width" />
  <P N="h" V="WebStiffHeight" D="Height" />
  <P N="clipV" V="WebStiffClipV" D="Vertical clip height" />
  <P N="clipH" V="WebStiffClipH" D="Horizontal clip width" />
</O>
</O>
</O>
</O>

```

#### 5.5.5.2 Vertical Stiffener

Stiffeners are defined as a Surface object with a thickness. A typical stiffener is rectangular with corner clips at the girder web/flange intersection. Figure 45 shows the required input parameters in the CADD view, and Figure 46 shows on the parameter input screen.

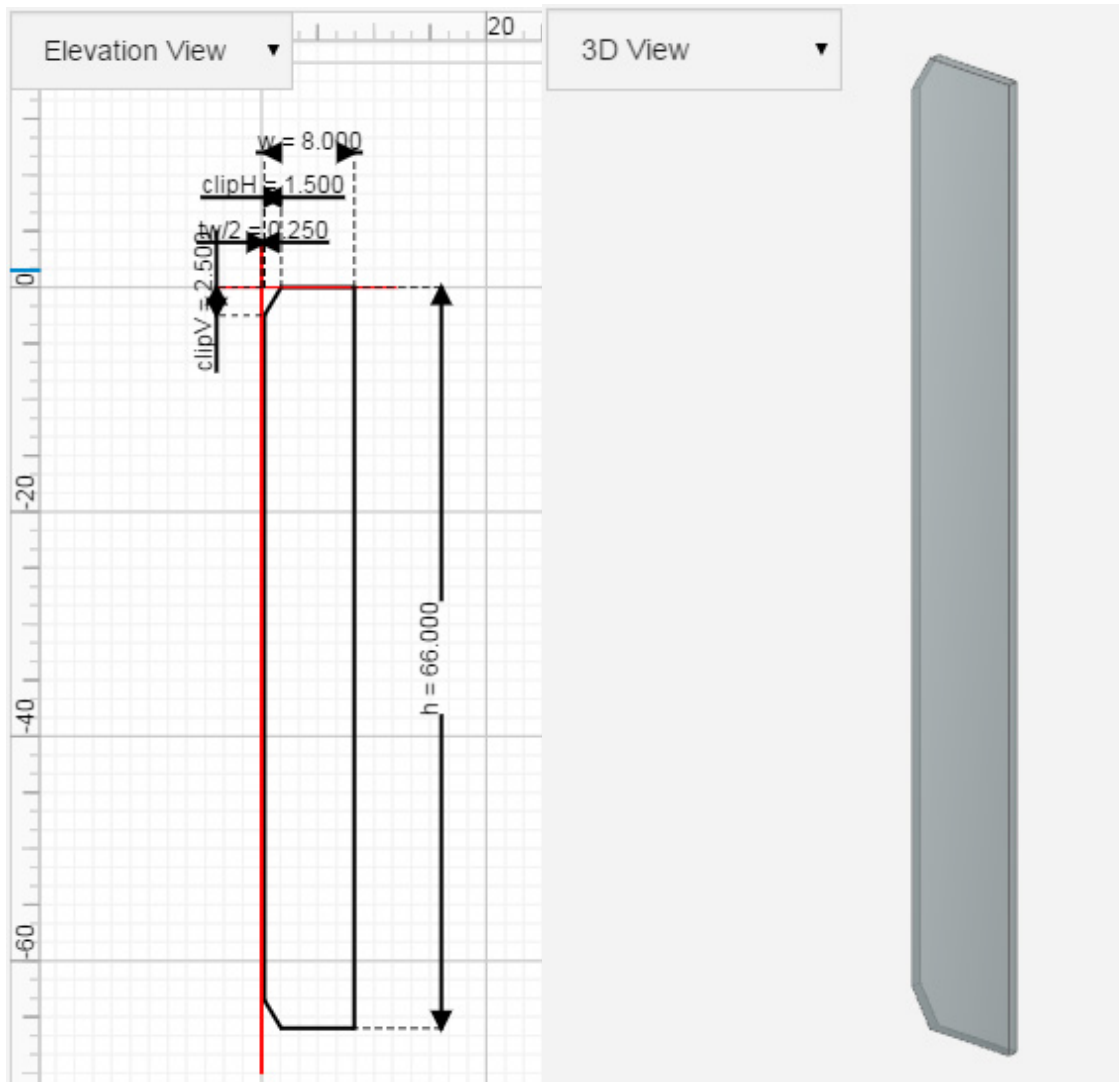

Figure 45 - Shear Stiffener Object

open  
Brim VerticalStiffener BY MIKE BARTHOLOMEW

Refresh

Dimensions

W Width	8	h Height	66	t Thickness	0.75
clipV Vertical clip height	2.5	clipH Horizontal clip width	1.5	tw Girder web thickness	0.5

Figure 46 - Shear Stiffener Input Data

The ParamML code for this type of element shown below is very simple. The additional code to develop the CADD view is included in Appendix A.

```

<O N="VerticalStiffener" T="Project">
  <O N="Dimensions" T="Group">
    <P N="w" V="8" D="Width" Role="Input" Category="Dimensions" />
    <P N="h" V="66" D="Height" Role="Input" Category="Dimensions" />
    <P N="t" V="0.75" D="Thickness" Role="Input" Category="Dimensions" />
    <P N="clipV" V="2.5" D="Vertical clip height" Role="Input" Category="Dimensions" />
    <P N="clipH" V="1.5" D="Horizontal clip width" Role="Input" Category="Dimensions" />
    <P N="tw" V="0.5" D="Girder web thickness" Role="Input" Category="Dimensions" />
  </O>
  <O T="Surface" X="t/2">
    <P N="Thickness" V="t" />
    <O T="Point" Y="clipH" Z="0" />
    <O T="Point" Y="w" Z="0" />
    <O T="Point" Y="w" Z="-h" />
    <O T="Point" Y="clipH" Z="-h" />
    <O T="Point" Y="0" Z="-h+clipV" />
    <O T="Point" Y="0" Z="-clipV" />
  </O>
</O>

```

### 5.5.5.3 Bolted Field Splice

One of the more complicated objects developed was the BoltedFieldSplice (BB) to join two girders with different plate thicknesses (see Figure 47). The object is comprised of multiple connection plates which are constructed as Surface objects with a thickness. All plates include holes for bolts. To account for the variation in web and flange thickness, additional fill plates are included on the thinner side of the connection. The BoltedFieldSplice (BB) object references other objects, including SplicePlate, Bolt (BB), and BoltGroup (BB).

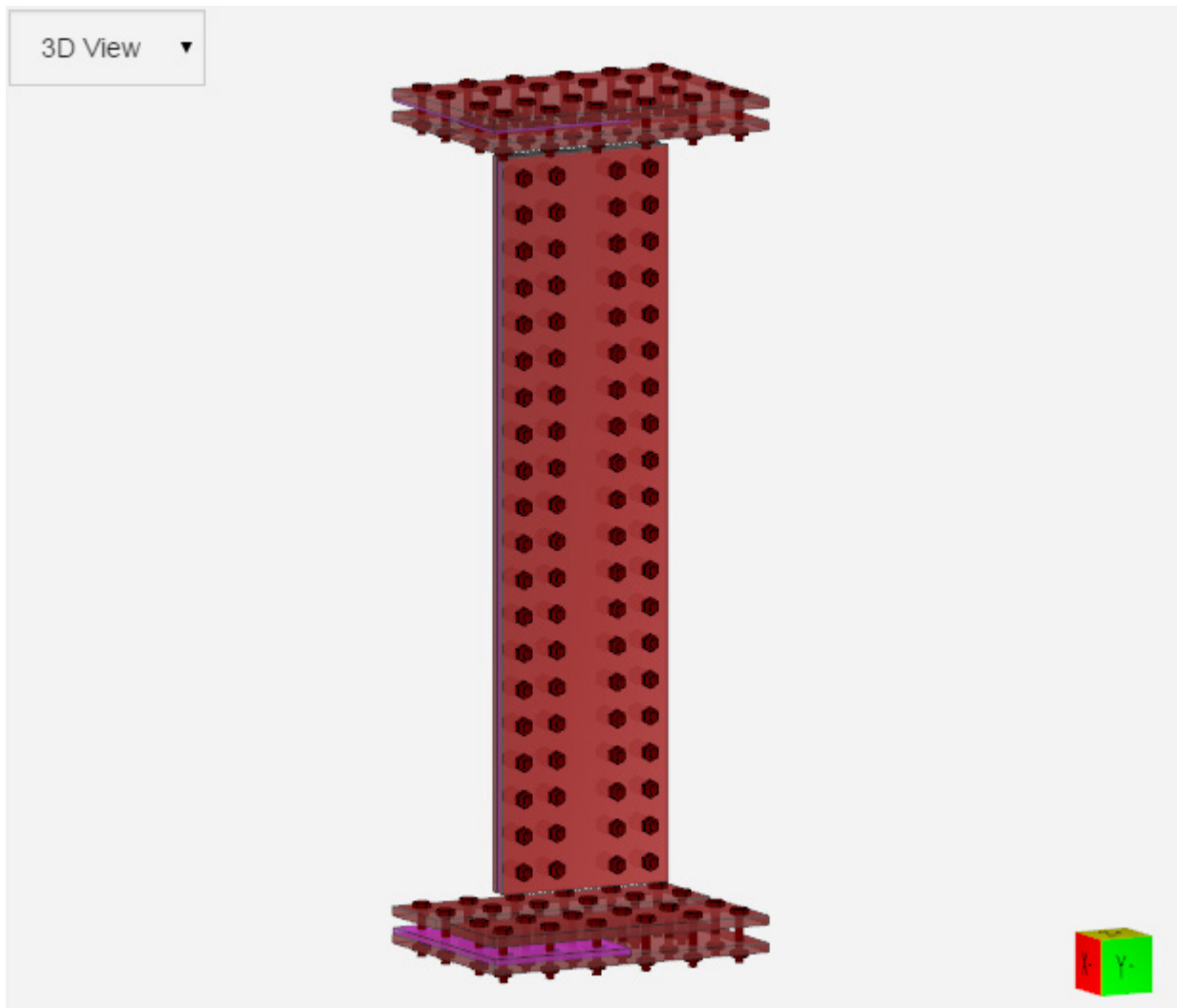

Figure 47 - Girder Bolted Field Splice

In addition to the flange and web splice plate thicknesses, the necessary input parameters for the BoltedFieldSplice (BB) object are the number and spacing of bolts on the flanges and web, and the edge distances for the bolts. See Figure 48 and Figure 49. The bolt spacing and edge distances determine the splice plate sizes.

While the splice object appears to be complex, it is constructed out of 12 individual plate Surface objects with thickness. The complexity is all in aligning the individual pieces together into a unit.

open BrIM BoltedFieldSplice (BB) BY BENJAMIN BLASEN

Refresh

Web Bolt Pattern ▼

WNUM_X the number of bolt columns in longitudinal axis per side	WSPC_X the spacing at center in longitudinal axis	WSP_X the spacing between bolts in longitudinal axis
2	5.5	3
wed_X the edge clearance in longitudinal axis	WNUM_Y the number of bolt rows in vertical axis	WSP_Y the spacing between bolts along vertical axis
1.75	20	3
wed_Y the edge clearance in vertical axis		
1.75		

Figure 48 - Web Field Splice Bolt Pattern Input

open BrIM BoltedFieldSplice (BB) BY BENJAMIN BLASEN

Refresh

Flange Bolt Pattern ▼

fnum_X the number of equally spaced bolts in longitudinal axis	fspc_X the spacing at center in longitudinal axis	fsp_X the spacing between bolts in longitudinal axis
3	4.5	4.25
fed_X the edge clearance in longitudinal axis	fnum_Y the number of equally spaced bolts in transverse axis	fsp_Y the spacing between bolts along transverse axis
1.75	2	4.25
fed_Y the edge clearance in transverse axis	fspc_Y the spacing at center in longitudinal axis	
1.75	6	

Figure 49 - Flange Field Splice Bolt Pattern Input

#### 5.5.5.4 Bolt

The Bolt (BB) object represents a bolt clamping two or more plates between two arbitrary points in space.

#### 5.5.5.5 Bolt Group

The Bolt Group (BB) object is a collection of bolts spaced in a rectangular grid. The bolt spacing in the two directions may be different, but all spaces in each direction are constant.

#### 5.5.5.6 Shear Stud

The Shear Stud object represents a shear connector welded to the top flange of a steel girder. It consists of a circular shaft and a larger diameter circular head. Both shaft and head are defined as Volume objects constructed using the Circle object between two points.

#### 5.5.5.7 Shear Stud Placement

The Stud Placement object is used to space groups of Shear Stud objects along the length of a steel girder. Objects can be spaced in multiple groups with variable spacing.

#### 5.5.5.8 Cross Frame Type K

This object is used for steel K-Type cross frame objects placed between steel I-girders. The basic geometry is defined by work point offsets from the top and bottom of web at the girder centerline. This configuration uses horizontal top and bottom chords, and two diagonals that intersect at the mid-length of the top chord. Chords and Diagonals are constructed from Line objects. The chords and diagonals are connected by welds to gusset plates. The four corner gusset plates include holes for a bolt group to be connected to stiffeners on the girders. The top center gusset plate is connected by welds only to the top chord and diagonals. The corner gusset plates reference the library object BoltedGusset, and the top center gusset plate uses the library object WeldedGusset.

The CADD drawing (Figure 50) depicts the configuration of the library object with the work points defined by the intersection of the red lines representing the center of gravity of the chords and diagonals. The girders are both at the same elevation. When positioned in a project with an alignment, the cross frame racks to take into account the girder geometric drop from the variable cross slope of the bridge deck (see Figure 51).

CrossFrameTypeKTop is the library name for this object, and it and any other types of cross frame are positioned in the bridge using the CrossFrameLayout object.

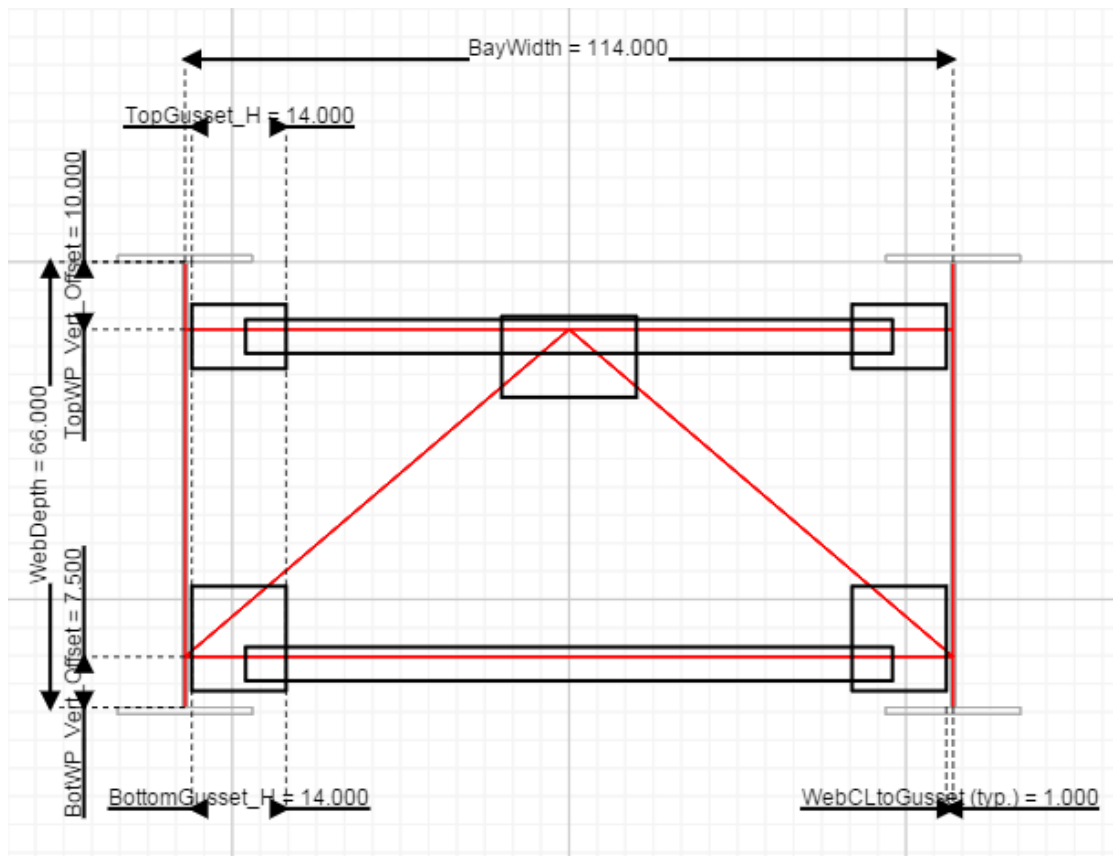

Figure 50 - Cross Frame Geometry from Library

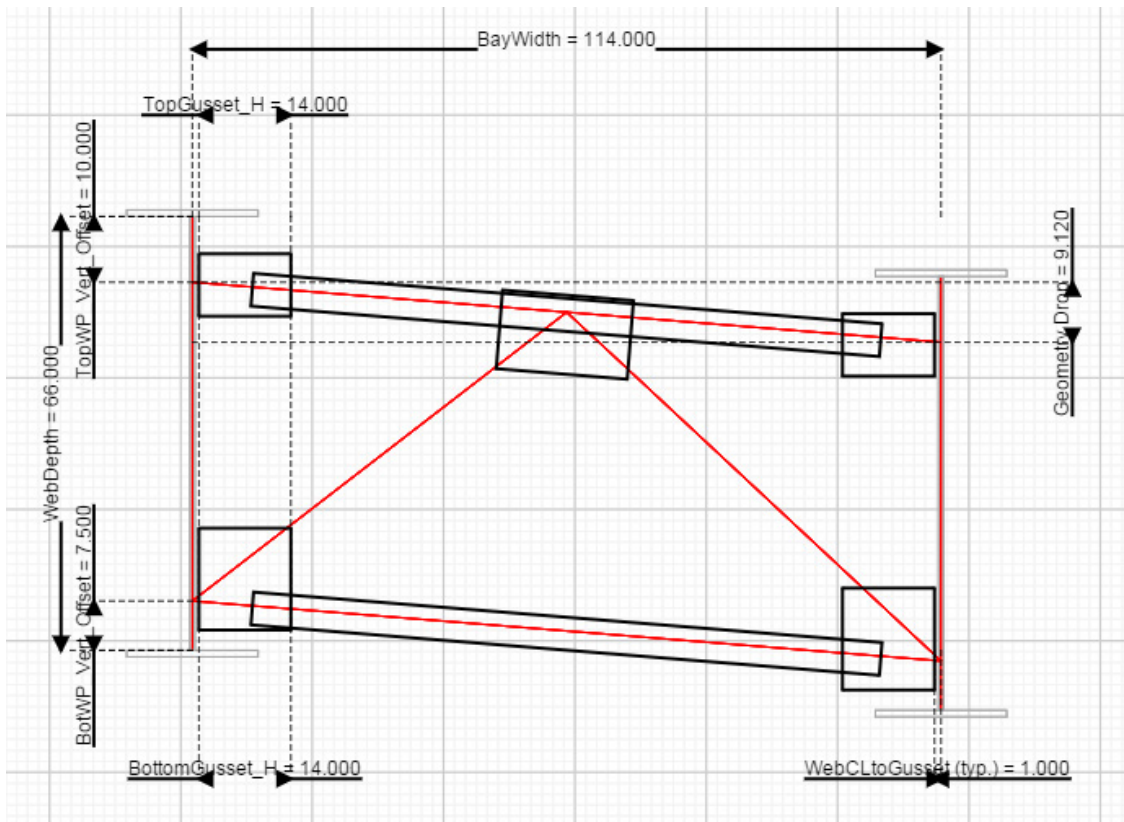

Figure 51 - Cross Frame Geometry in Project



#### 5.5.5.9 Bolted Gusset

**BoltedGusset** object is used for Cross Frame Gusset connection plates. The plate is defined as a surface with thickness. It contains bolt holes as cutout sub-surfaces. There are two nested Repeat objects that are used to create holes in both Y and Z direction of the plate. The outer repeat is along the Z axis (uses j control parameter) and the inner repeat is along Y axis (uses i control parameter). Parameters spY and spZ are the spacing along Y and Z axis, respectively. Parameters locY and locZ define the location of the hole.

#### 5.5.5.10 Welded Gusset

**WeldedGusset** object is used for Cross Frame Gusset connection plates. The plate is defined as a surface with thickness, and is intended for fully shop welded connections.

#### 5.5.5.11 Cross Frame Layout

**CrossFrameLayout** uses the Repeat object to generate multiple cross frames along a bridge at locations determined by the array parameter CrossFrameLocations. This array contains the stations along the alignment line where the cross frames are positioned longitudinally. Cross frames are located in bays defined by the transverse horizontal offsets of the two girders that they connect. All cross frames have been assumed to be oriented normal to the alignment line.

#### 5.5.5.12 Plate Diaphragm

**Diaphragm** object is used for creating a steel girder type diaphragm. Diaphragms can be defined as a single object for the entire cross section of the bridge, or as individual sections between girders. The cross section is comprised of a web and top and bottom flange plates. The diaphragm also allows for inclusion of jacking stiffeners, fill plates, and splice plates. Because the plate diaphragms are located at the abutments, they are used for to accommodate future bearing replacement and have their bottom flanges horizontal. The top flanges serve as a support for the end of the bridge deck, and therefore follow the slope of the roadway. The webs of the ends of each diaphragm are bolted to the bearing stiffeners of the girders with splice plates (see Figure 52).

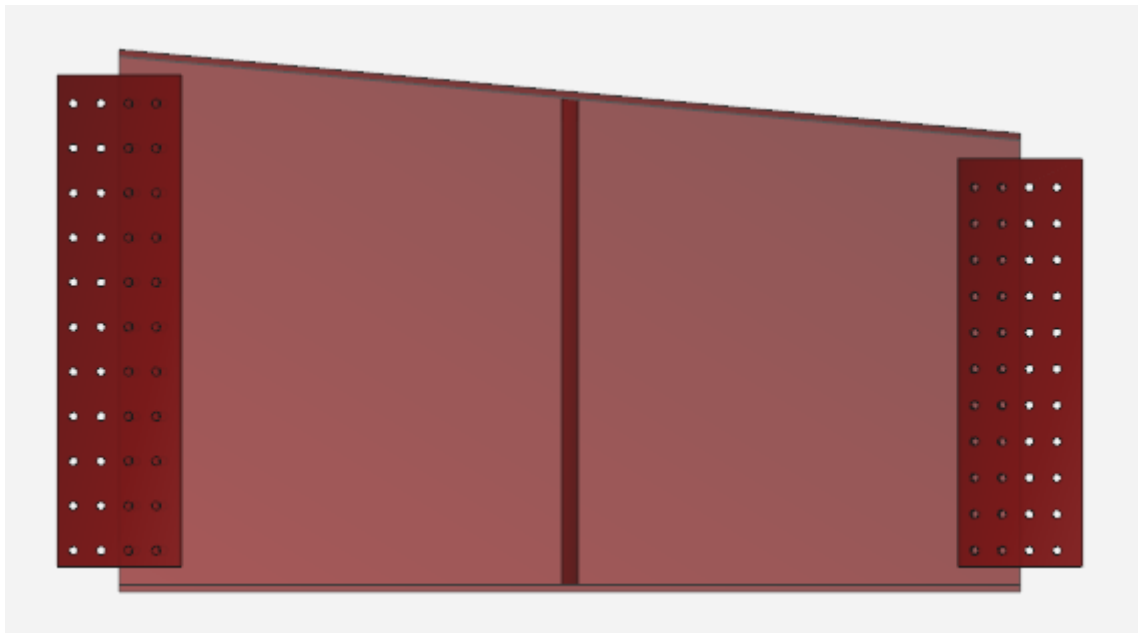

Figure 52 - Plate Diaphragm

## 5.5.6 Decks

### 5.5.6.1 Deck

Deck object is used for creating cast-in-place concrete bridge decks on girders. The cross section of the top of deck follows the alignment cross slope of the bridge, and the bottom of deck includes the build-up or haunches for the girders. The deck object also follows the horizontal alignment and vertical profile. Girder deck overhang options include constant thickness, or variable thickness from deck edge to the exterior girder haunch. The deck component is defined as a Volume object created as an extrusion between two Surface objects. The Surface objects are the cross sections at each end of the deck section. Currently it is limited to a constant width roadway. Deck geometric configuration is shown in Figure 53. An alignment was included in the library object definition to show how variable cross slope is handled.

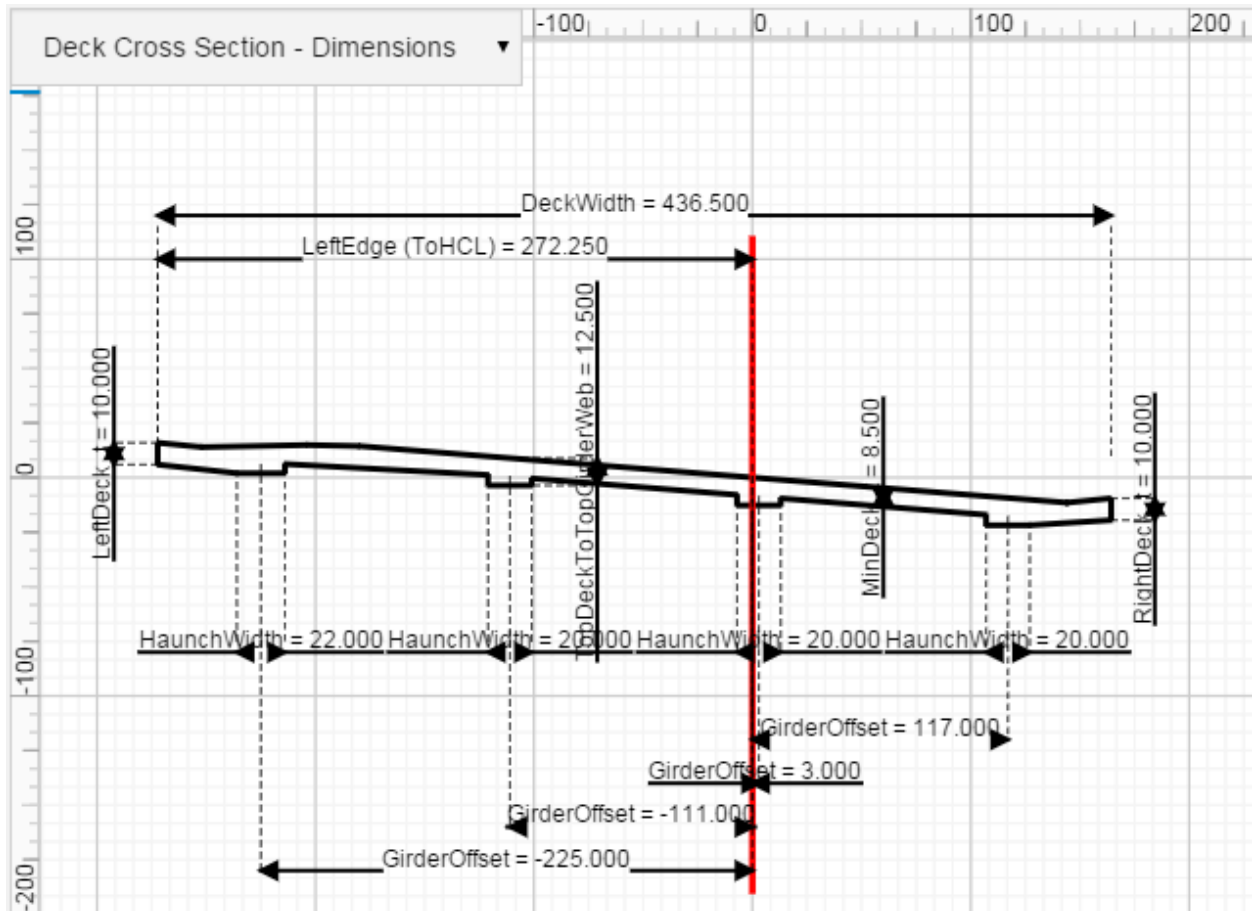

Figure 53 - Deck Cross Section

The corresponding input parameters are shown on the data entry screen in Figure 54, and consist of the overall deck width, distance from the left edge of deck to the HCL, the deck thickness between girders, at each edge, and at the girder centerline haunches, and the girder transverse offsets from the HCL and the haunch widths (as arrays). Changing the number of values in the array for transverse offsets allows the use of any number and spacing of girders. This can be done without modifying the code for the deck object, which makes it very versatile. 3-D representations of a portion of a deck are shown in Figure 55 and Figure 56. The views illustrate how the deck can vary with an exaggerated change in cross slope over a short distance, even with a very minimal amount of data definition.

open  
BrIM Deck BY MIKE BARTHOLOMEW

Refresh

Deck Parameters ▾

DeckWidth	436.5	MinDeck_t	8.5	TopDeckToTopGirderWeb	12.5
LeftDeck_t	10	RightDeck_t	10	LeftOverhangType	1
RightOverhangType	1	LeftEdge	272.25	GirderOffset	[117, 3, - 111, - 225]
HaunchWidth	[20, 20, 20, 22]				

Figure 54 - Deck Input Parameters

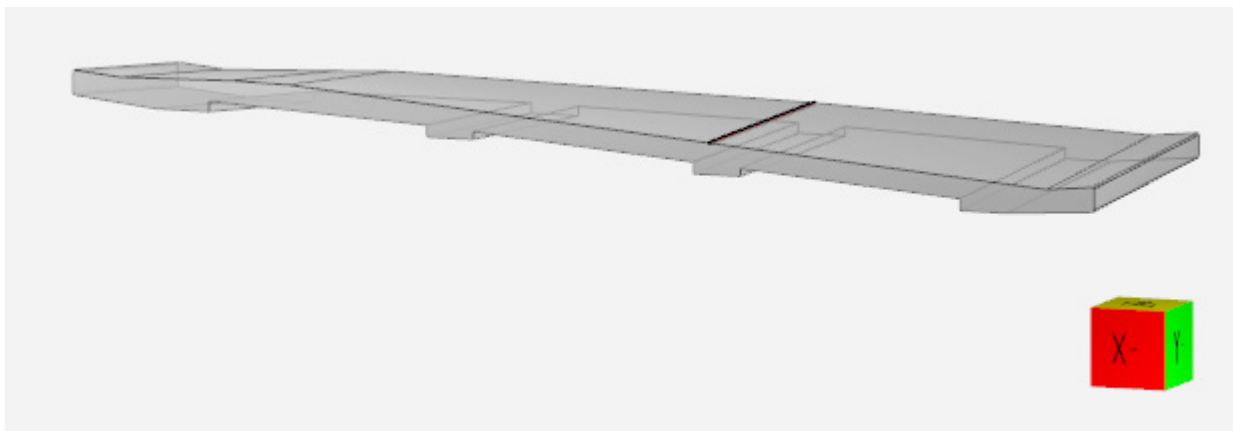

Figure 55 - 3-D Representation of Deck

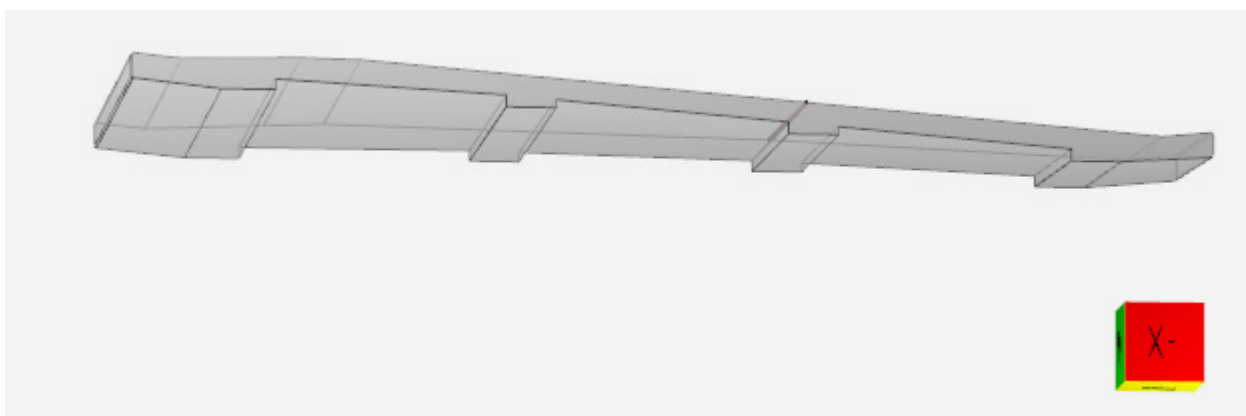

Figure 56 - 3-D Representation of Deck from Below

The following code is used to create one Surface object consisting of only four points to define the top and bottom edges of the deck slab, four points for each interior girder haunch, and either three or four

points for each of the two exterior girder haunches, depending on the overhang type selected. The code uses the Repeat object to create the haunch corner points, the Guard parameter to eliminate one point when the deck overhang thickness varies from the exterior girder haunch to the edge. In addition the alignT() function is used to adjust the bottom of the haunch to be level over the girders when there is a cross slope of the top of the deck. A second surface is created at the ending station, and the start surface is extruded to the end surface. When rendering a deck, one hundred additional intermediate surfaces are created between the two end surfaces.

```
<O N="Section1" T="Surface" X="StartStation">
  <O T="Point" C="0.75" Z="0" Y="RightEdge" />
  <O T="Point" C="0.75" Z="-RightDeck_t" Y="RightEdge" AlignTB="0" />
  <O T="Repeat" index="S" CTRL="index" I="1" E="numGirders-1" S="0">
    <P N="GA" V="alignT(CSAlignment, StartStation, GirderOffset[index]-0.5*HaunchWidth[index])" />
    <P N="CL" V="alignT(CSAlignment, StartStation, GirderOffset[index])" />
    <P N="GB" V="alignT(CSAlignment, StartStation, GirderOffset[index]+0.5*HaunchWidth[index])" />
    <P N="ElevCorrA" V="GA-CL" />
    <P N="ElevCorrB" V="GB-CL" />
    <O T="Point" Z="-MinDeck_t" Y="GirderOffset[index]+0.5*HaunchWidth[index]" AlignTB="0">
      <P N="Guard" V="(RightOverhangType.NE.1).OR.(index.NE.S)" />
    </O>
    <O T="Point" Z="-TopDeckToTopGirderWeb-ElevCorrB" Y="GirderOffset[index]+0.5*HaunchWidth[index]"
AlignTB="0" />
    <O T="Point" Z="-TopDeckToTopGirderWeb-ElevCorrA" Y="GirderOffset[index]-0.5*HaunchWidth[index]"
AlignTB="0" />
    <O T="Point" Z="-MinDeck_t" Y="GirderOffset[index]-0.5*HaunchWidth[index]" AlignTB="0">
      <P N="Guard" V="(LeftOverhangType.NE.1).OR.(index.NE.E)" />
    </O>
  </O>
  <O T="Point" C="0.75" Z="-LeftDeck_t" Y="-LeftEdge" AlignTB="0" />
  <O T="Point" C="0.75" Z="0" Y="-LeftEdge" />
</O>
```

#### 5.5.6.2 Deck End Beam

DeckEndBeam object is used for creating the thickened end beam for cast-in-place concrete bridge decks on girders. The beam accounts for the slab bending at the free edge of deck, and accommodates an expansion joint blockout. The cross section of the top of deck follows the alignment cross slope of the bridge. The thickened section transitions to the typical deck cross section where the bottom of the deck includes the build-up or haunches for the girders.

### 5.5.7 Bridge Railings

#### 5.5.7.1 Traffic Barrier

The PA Turnpike Barrier object is another object created by extruding a Section object along a Line object. In this case the Line is at the top of the deck at the inside face of barrier. The Section uses fixed dimensions for this particular barrier shape.

### 5.5.8 Miscellaneous

#### 5.5.8.1 Bent Rebar

BentRebar object is used as the basic template for all bent reinforcing steel bars. It is anticipated that individual bar bend types will be developed parametrically with their own library objects, and will reference this object. Any number of legs can be incorporated by the BentRebar object by increasing the number of array elements for the input parameters Length, AngleX, AngleY, and AngleZ. BentRebar uses

the Line object with the Polyline="1" parameter. The polyline is created along the centerline of the bar. Standard bar bend diagrams are detailed with to out-to-out dimensions, so individual bar bend objects will need to account for the difference in leg lengths and the bend radius. An example stirrup bar is shown in Figure 57.



Figure 57 - Reinforcing Stirrup Bar Bend



# Section 6 – Bridge Modeling

To test the capability of OpenBrIM to build a complete bridge model from standard components, the Ramp 119 S-N structure previously identified in Section 5 was used. The complete model template file is attached in Appendix B, and an overall graphic view is shown in Figure 58.

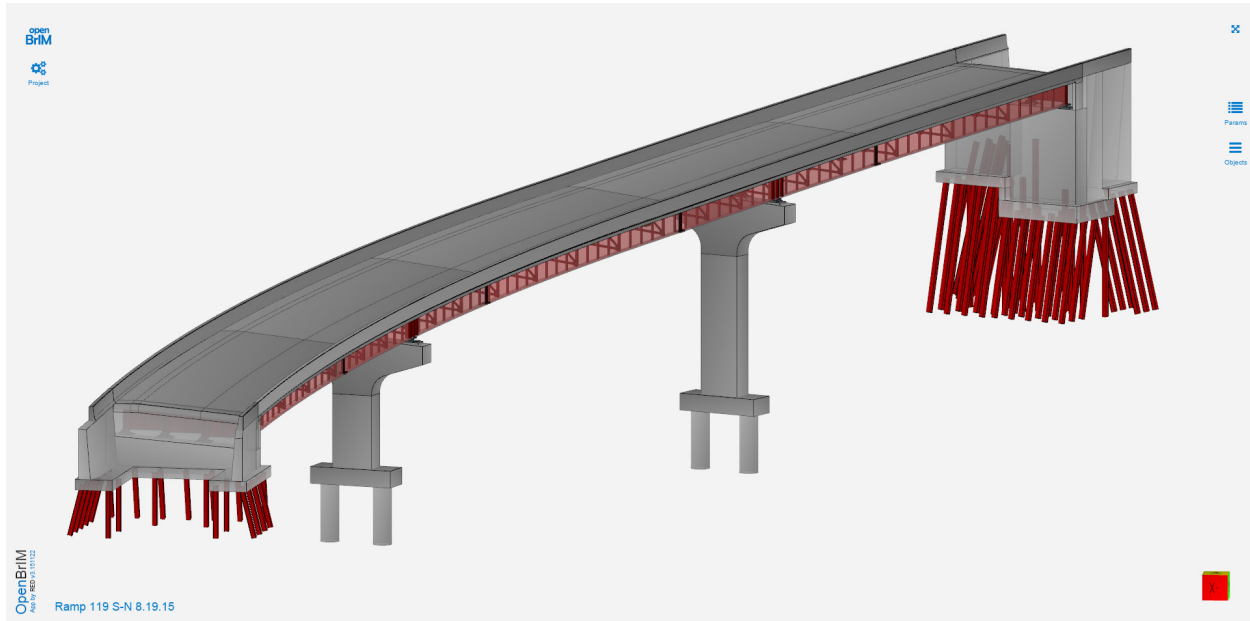

Figure 58 - Full Model of Ramp 119 S-N

## 6.1 Building BrIM Models

OpenBrIM App supports model building through the GUI. Figure 59 - OpenBrIM App Interface show the steps required to start creating a model.

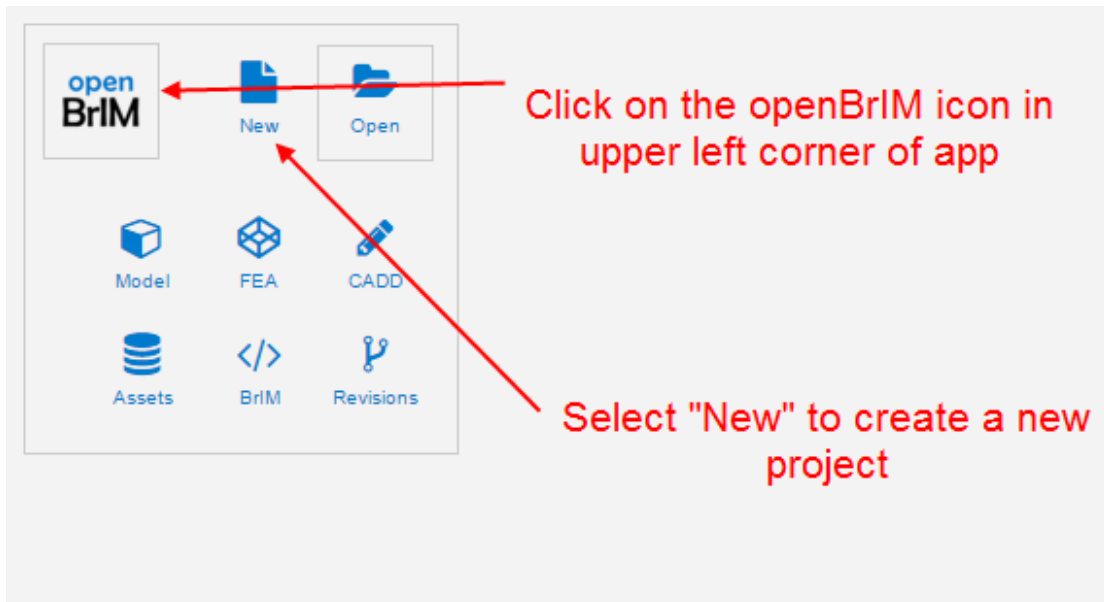

Figure 59 - OpenBrIM App Interface

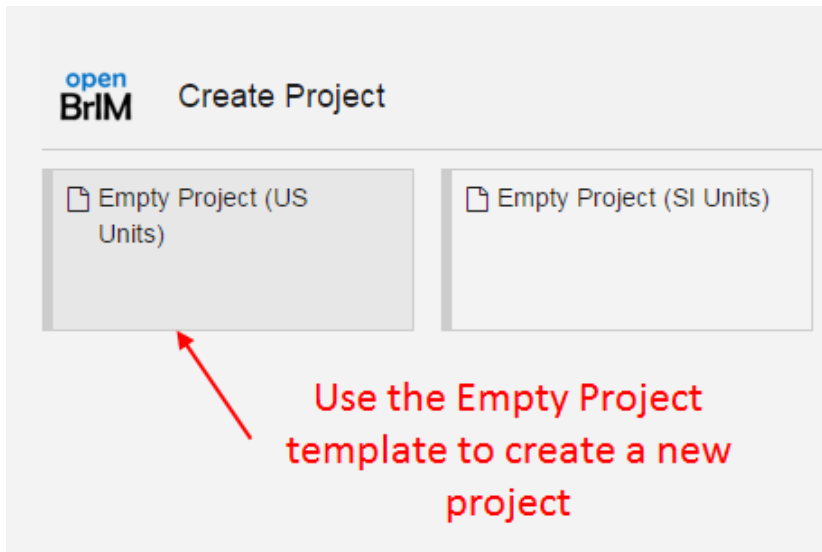

Figure 60 - OpenBrIM App - Create Project



Figure 61 - OpenBrIM App Add Object

The New Object dialog box (see Figure 62) lists different types of objects in a dropdown list including Basic, Alignment, Geometry, and user's libraries. The figure below shows a Drilled Shaft user library object for selection.

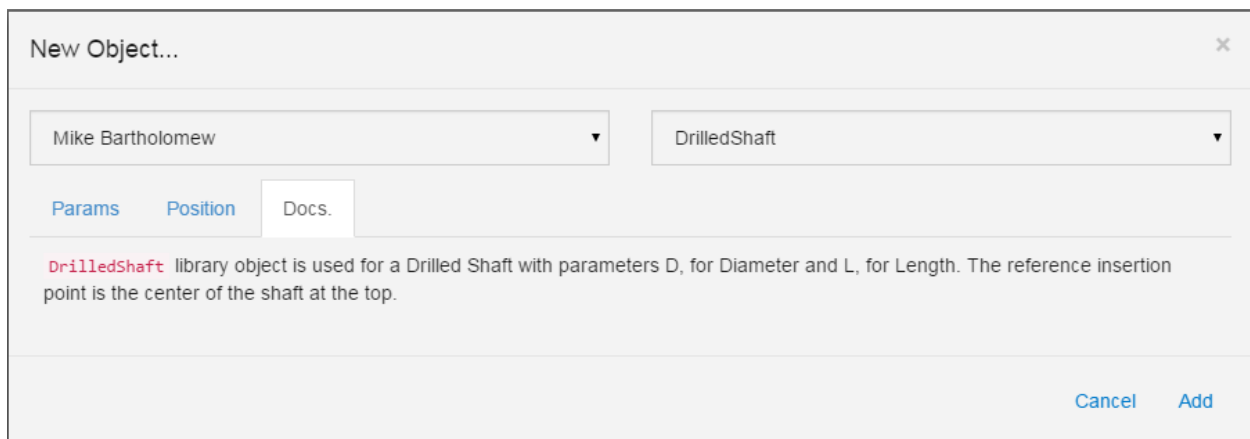

Figure 62 - New Object Documentation Dialog Box



### 6.1.1 Example Object Creation

Objects generally contain tabs for parameters to define the shape of the object, the geometric location within the project, and documentation on its use.

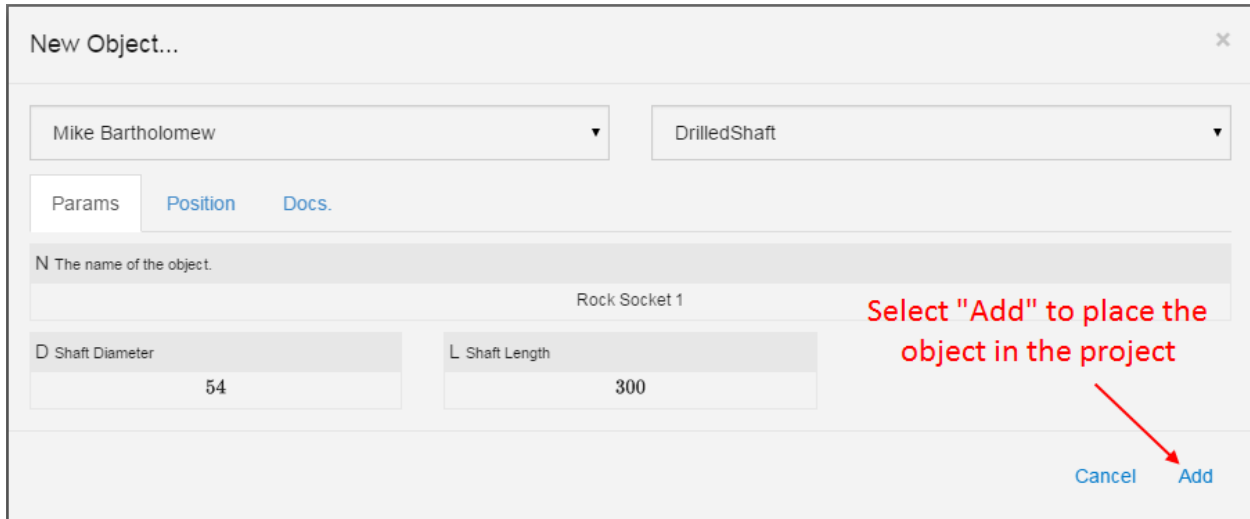

Figure 63 - New Object Parameters Dialog Box

The new object is added with either the default values shown in the dialog box or with user entered values (see Figure 63). When the object is selected in the 3-D view, it is highlighted in red, and any dimensions that are associated with it are displayed.

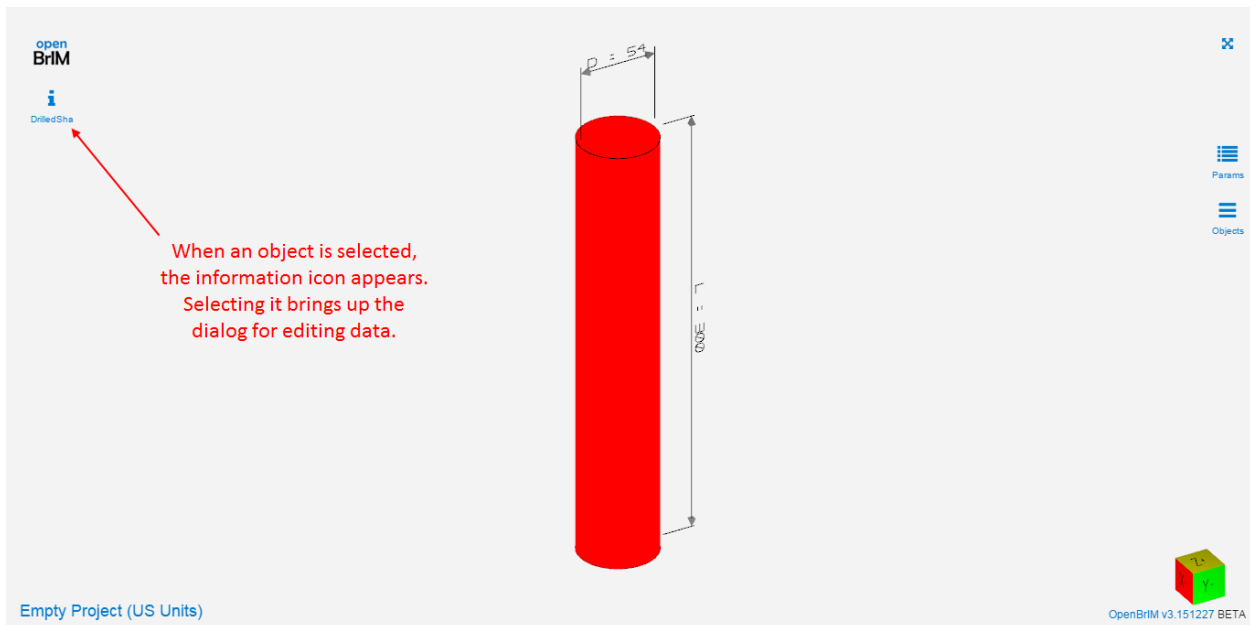

Figure 64 - Model View of Added Object

## 6.2 Positioning Component Objects

The major categories of structural components for bridges have already been identified in Section 5 as abutments, piers, bearings, girders and framing, deck, and railings/barriers. Substructure components, like abutments and piers, are essentially smaller structures that are designed and built within their own reference coordinate systems. Abutments use their own transverse centerline and the longitudinal centerline of bearing as their plan reference system. Piers generally are defined relative to their own transverse and longitudinal centerlines. It is standard convention to define and group all abutment and pier sub-components relative to their own plan reference systems. Often the centerline reference system for substructure units is offset transversely from the principal roadway horizontal control line (HCL). Both abutments and piers are located so that their top surfaces (or bearing seats) are positioned with respect to the superstructure depth, vertical profile grade line (PGL), and cross slope geometry. Foundations for substructures are generally positioned vertically based on the existing or future ground surface. Superstructure items, like girder framing, decks, and railings/barriers can be located in the bridge by referencing station and offset on the HCL and elevation from the PGL.

### 6.2.1 Example Object Positioning

The drilled shaft object that was created in the previous section was automatically placed at a position of X=0, Y=0, and Z=0 in the project. To reposition it, select the object, then select the information icon in the upper left corner of the 3-D view to bring up the Edit object dialog box. On the Position tab there are data entry locations for translation in, or rotations about the X, Y, and Z axes (see Figure 65).

The screenshot shows the 'Edit DrilledShaft...' dialog box with the 'Position' tab selected. The dialog is divided into three columns for X, Y, and Z axes. Each column has three input fields: translation (TX, TY, TZ), rotation (RX, RY, RZ), and rotation origin (AX, AY, AZ). The TY field is highlighted with a red arrow and a red text label: 'Translate the object -81 units in the Y-direction'. The TY field contains the value '-81'. Other fields contain '0'. At the bottom, there are 'Delete', 'Cancel', and 'Apply' buttons.

TX Translation along X axis to move the object.	TY Translation along Y axis to move the object.	TZ Translation along Z axis to move the object.
0	-81	0
RX Rotation about X axis to rotate the object.	RY Rotation about Y axis to rotate the object.	RZ Rotation about Z axis to rotate the object.
0	0	0
AX X location of the rotation origin.	AY Y location of the rotation origin.	AZ Z location of the rotation origin.
0	0	0

Figure 65 - Edit Object Dialog Box

A second drilled shaft can be positioned as it is created. The selected shaft in Figure 66 was created at TY = 81 units. Now the project has two shafts 162 units apart.

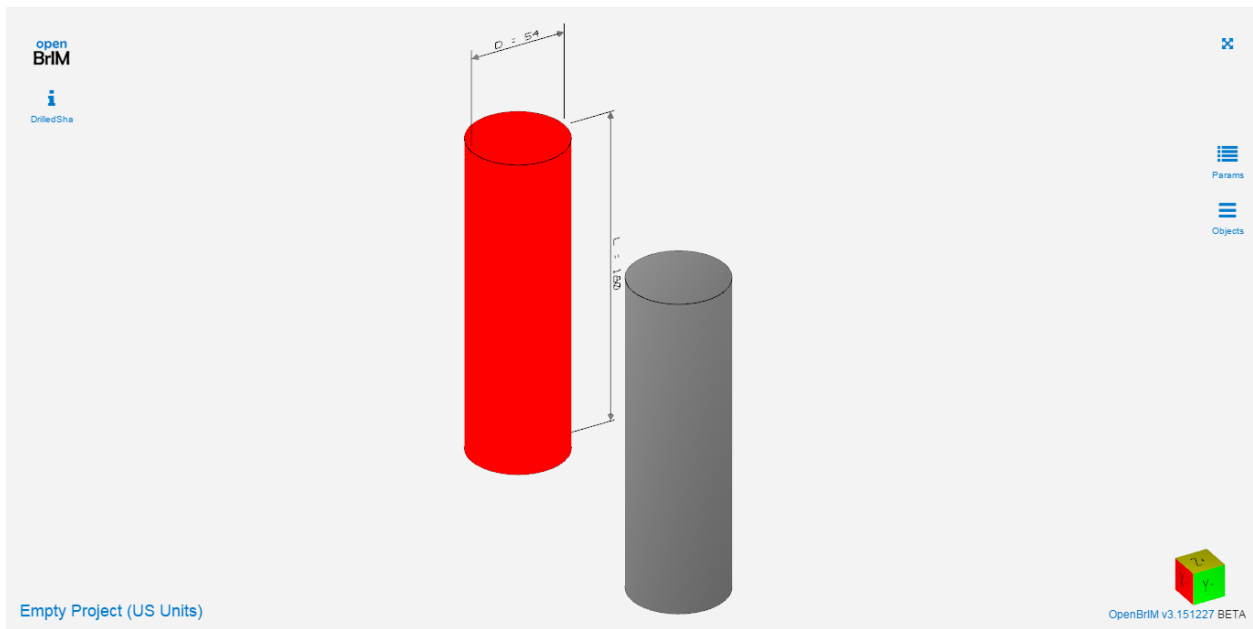

Figure 66 – Model View of Multiple Drilled Shafts

The ParamML code generated by this process is:

```

<O N="Rock Socket 1" T="DrilledShaft" Y="-81">
  <P N="L" V="180" />
  <P N="D" V="54" />
</O>
<O N="Rock Socket 2" T="DrilledShaft" Y="81">
  <P N="L" V="180" />
  <P N="D" V="54" />
</O>

```

## 6.3 Grouping and Hierarchy of Components

Grouping of objects is an important feature of the OpenBrIM App and of the data structure. Group objects are primarily used for organizational purposes to collect logically related items together. Groups can contain Objects and Parameters, and even other Groups. Groups can be nested in a multiple level hierarchical structure. When objects are grouped, the OpenBrIM App allows individual objects or object groups to be visible or not visible by using the Object Explorer (see Figure 67).

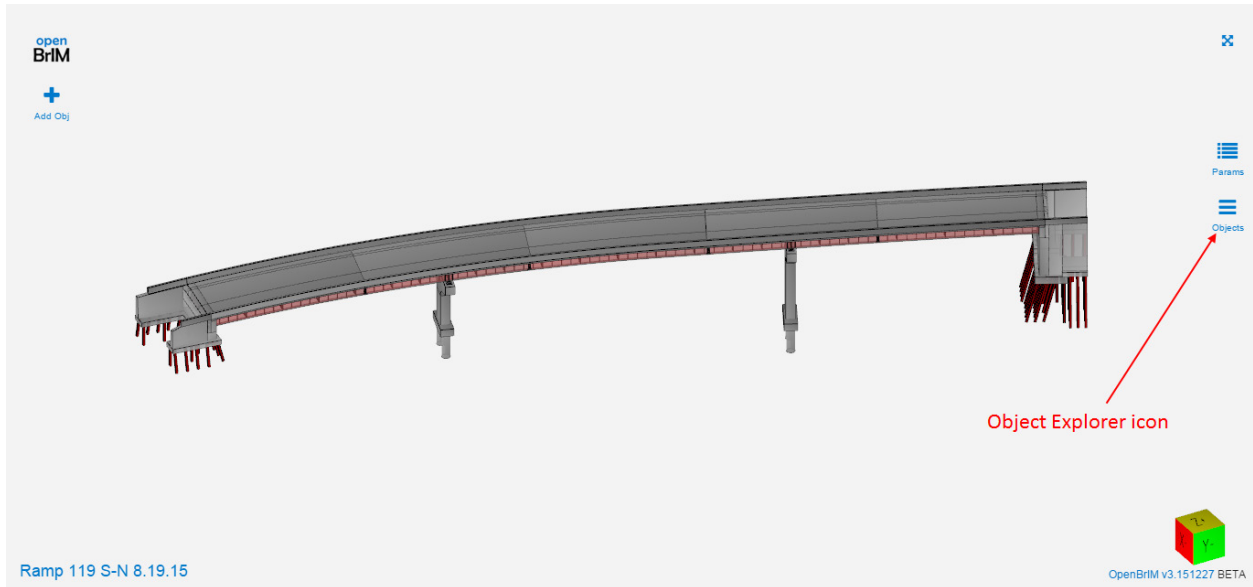

Figure 67 - Model View Object Explorer

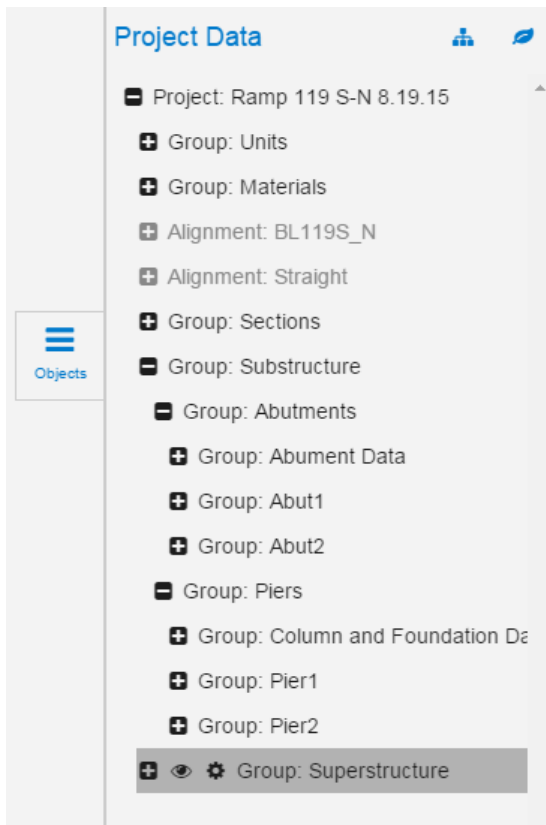

Figure 68 - Object Explorer Window

Figure 68 shows the OpenBrIM App Object Explorer window. The associated ParamML code (without all of the objects and parameters inside the groups) is as follows:

```
<O N="Substructure" T="Group">
  <O N="Abutments" T="Group">
    <O N="Abument Data" T="Group">
      </O>
    <O N="Abut1" T="Group">
      </O>
    <O N="Abut2" T="Group">
      </O>
    </O>
  <O N="Piers" T="Group">
    <O N="Column and Foundation Data" T="Group">
      </O>
    <O N="Pier1" T="Group">
      </O>
    <O N="Pier2" T="Group">
      </O>
    </O>
  </O>
</O>
```

It is convenient to make an entire group not visible to make it easier to view portions of the model. This is done by toggling the visibility icon on and off for a large group such as the Superstructure shown in Figure 69.

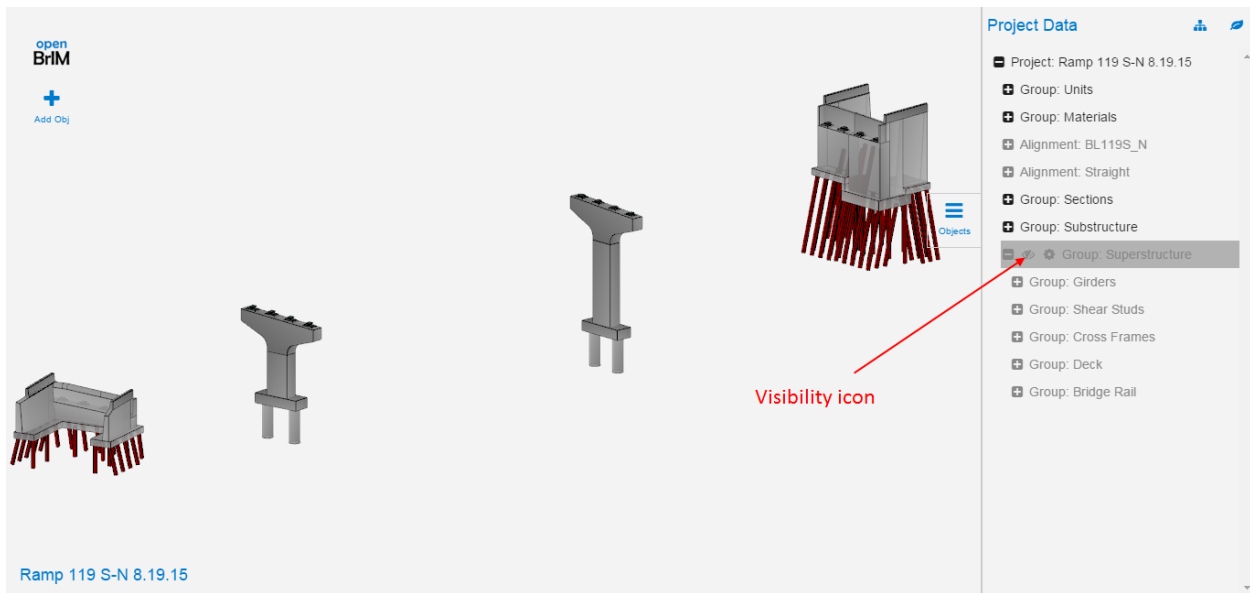

Figure 69 - Model View with Object Explorer Open

One of the most useful features of grouping is that objects in groups inherit the properties of the group. If all of the objects in a pier are part of the same group, then the whole pier unit can be positioned or oriented by applying a translation or rotation to the group.

### 6.3.1 Example Object Grouping

In the previous example, the two individual drilled shaft objects can be placed in the same group simply by enclosing the two objects within a starting and ending Group object tag, as shown below.

```
<O N="DrilledShafts" T="Group">
  <O N="Rock Socket 1" T="DrilledShaft" Y="-81">
    <P N="L" V="180" />
    <P N="D" V="54" />
  </O>
  <O N="Rock Socket 2" T="DrilledShaft" Y="81">
    <P N="L" V="180" />
    <P N="D" V="54" />
  </O>
</O>
```

Rotating the two shafts 90° or  $\pi/2$  radians about the group centroid is accomplished by adding the parameter  $RZ=\pi/2$  to the DrilledShafts group object. The results are shown in Figure 70.

```
<O N="DrilledShafts" T="Group" RZ="PI/2">
  <O N="Rock Socket 1" T="DrilledShaft" Y="-81">
    <P N="L" V="180" />
    <P N="D" V="54" />
  </O>
  <O N="Rock Socket 2" T="DrilledShaft" Y="81">
    <P N="L" V="180" />
    <P N="D" V="54" />
  </O>
</O>
```

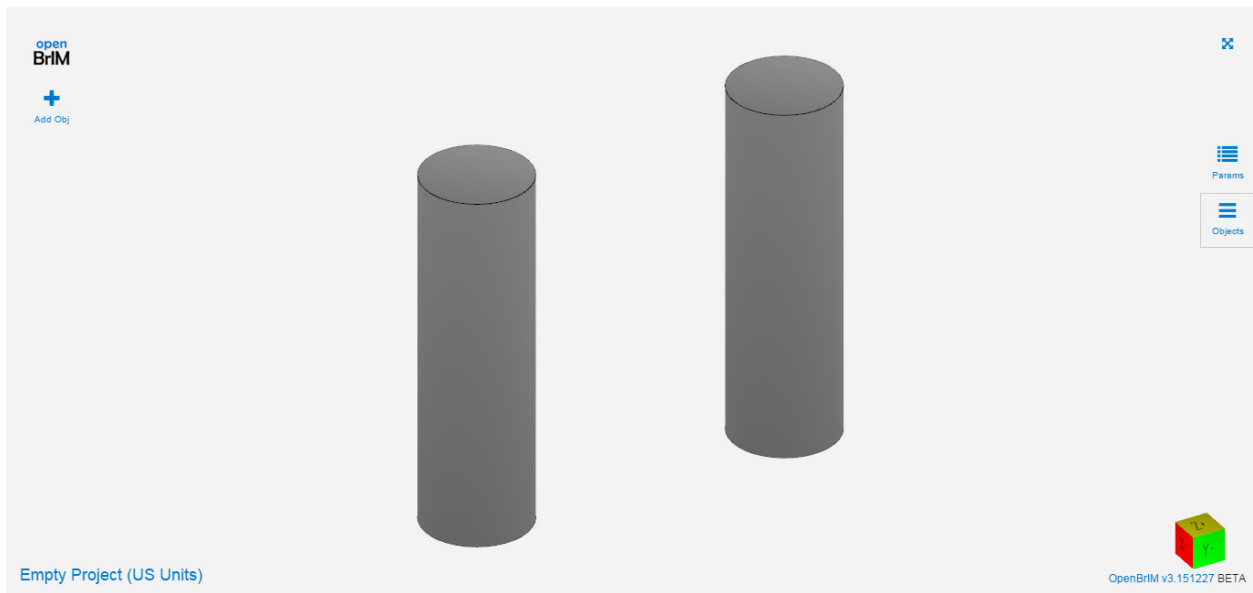

Figure 70 - Model View of Drilled Shafts Rotated 90°

## 6.4 Locating and Orienting Components to Alignments

The real power of OpenBrIM is its ability to position component objects to a project alignment. All bridge components are located according to their station and transverse offset from the HCL, and their vertical offset from the PGL. The project alignment is a coordinate system in itself, with stationing denoted as X, transverse offset as Y, and vertical offset as Z, and is not to be confused with a traditional X, Y, and Z axes of a Cartesian coordinate system. In OpenBrIM, position of an object is generally included on the object definition line as:

```
<O N="FieldSection1" T="SteelGirderMB" X="1000" Y="48" Z="-12">
```

In addition, components must be oriented with respect to the HCL, PGL, and the Cross Slope of the roadway using the AlignH, AlignV, and AlignT parameters given in Section 5.4.4. These parameters have three settings, "Warp", "Orient", and "None", and the setting type is a function of the type of primitive object that the component is defined from (Line, Surface, or Volume). For Line objects, there is also a different behavior for vertically oriented versus horizontally oriented. Figure 71 shows a plan view of a test project used to visualize the behavior. The alignment is a sharp horizontal curve. The blue components are Volume objects, red are Line objects, and green are Surface objects. There are five test groups for bridge deck components, vertical columns, straight beams, horizontally curved beams, and beams tilted along their primary axis.

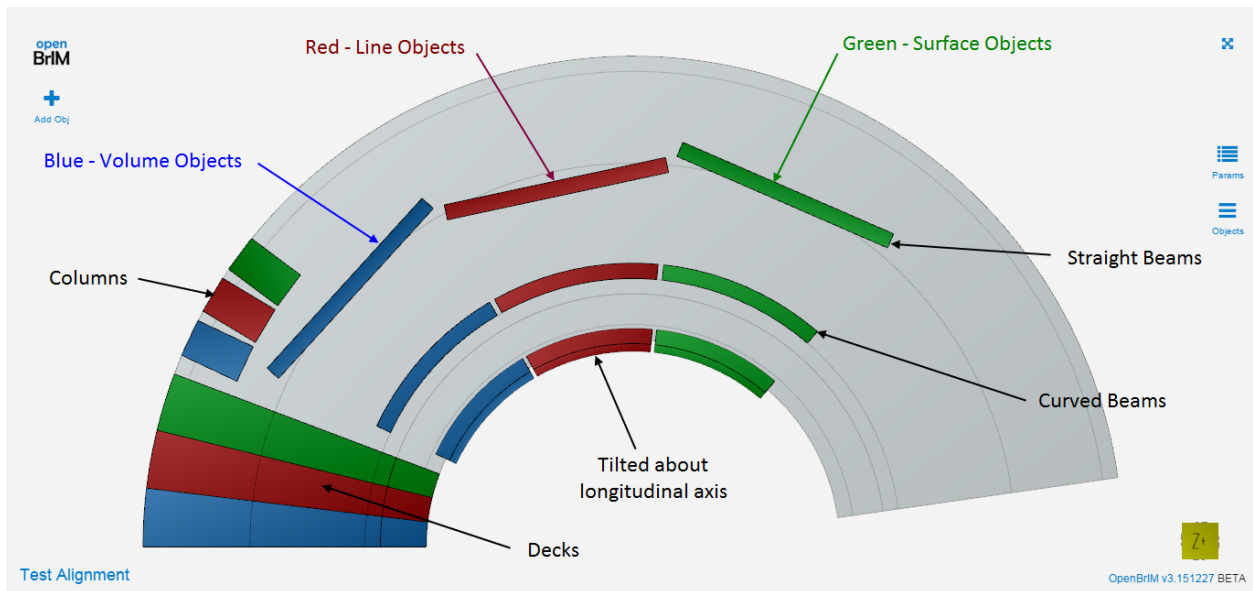

Figure 71 - Use of Align Parameters

The only noticeable difference in any of the test cases is the straight beam behavior, which uses the parameters `AlignH="Orient"`, `AlignV="None"`, and `AlignT="None"` for both Volume and Surface objects. For the Line object, `AlignH="None"`. The close-up, Figure 72, shows that the Line object for a straight horizontal beam has its end points located on the alignment, whereas the Volume and Surface objects have their centroid on the alignment. For beams chorded along a curved alignment, it is simpler to define the beam library component with the Line object for use in a project.

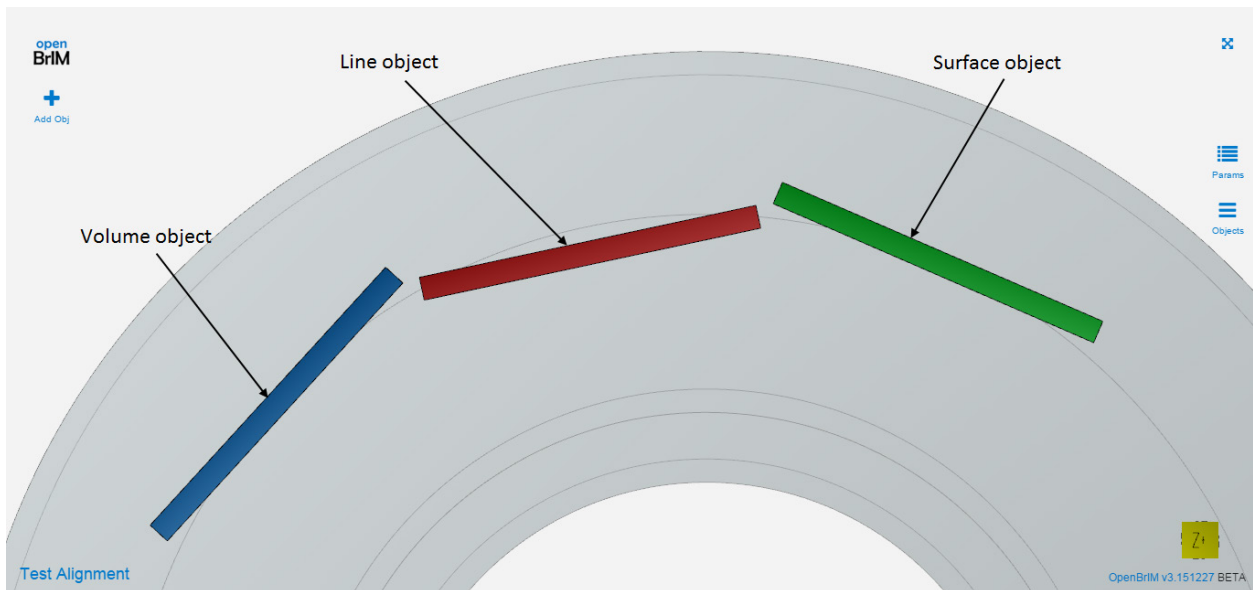

Figure 72 - Straight Beam Behavior

Typically, when the parameter `AlignH="Warp"`, the object will follow the horizontal alignment. If in a curve, the object will be curved, and when in a tangent section, it will be straight. This is the typical orientation setting for a horizontally curved steel girder bridge. If the girder is intended to be chorded around the horizontal curve, `AlignH="None"` is the appropriate setting. If the setting is `AlignH="Orient"`, and the girder is constructed with a Line object, it will have the same behavior as the Volume and



Surface objects, where the point at mid-span is on the alignment. When `AlignV="Warp"`, objects follow the vertical curve profile. `AlignT="Warp"` is typically used for bridge deck sections or surfaces normal to the HCL being extruded along the HCL. The top edge of such an object will take on the transverse cross section profile of the alignment without having to specifically define break points in the object.

### 6.4.1 Example Deck Section

The bridge deck section for Ramp 119 S-N seen in Figure xxx, uses an insertion point definition as the HCL at the top of deck. Therefore, the horizontal and vertical are zero, which is the default value for the Y and Z-coordinates. To use this deck section in a project, requires the following minimal ParamML code.

```
<O N="Deck" T="Group" AlignT="Warp" AlignH="Warp" AlignV="Warp">
  <P N="DeckWidth" V="436.5" />
  <P N="MinDeck_t" V="8.5" />
  <P N="TopDeckToTopGirderWeb" V="12.5" />
  <P N="LeftDeck_t" V="10" />
  <P N="RightDeck_t" V="10" />
  <P N="LeftOverhangType" V="1" />
  <P N="RightOverhangType" V="1" />
  <P N="LeftEdge" V="272.25" />
  <P N="GirderOffset" V="[117, 3, -111, -225]" />
  <P N="HaunchWidth" V="[18, 16, 16, 22]" />
  <O N="DeckPour1" T="Deck">
    <P N="StartStation" V="73525.75" />
    <P N="EndStation" V="74520" />
  </O>
</O>
```

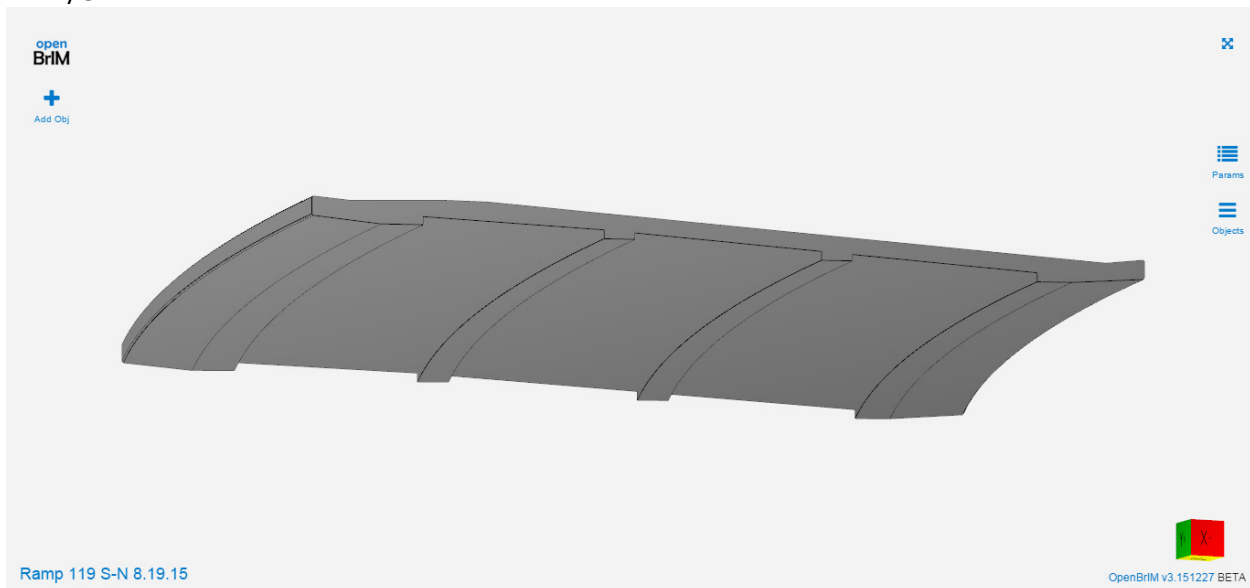

The `AlignH`, `AlignV`, and `AlignT` parameters are all set to “Warp” for the entire “Deck” group. This makes the deck follow the HCL, PGL, and the cross section variation. The ten parameters define the shape of the deck. Those parameters are inherited by the object named “DeckPour1”, which references the standard library object “Deck”. Each deck pour section requires only the parameters “StartStation” and “EndStation”, which are its X-coordinates at each end. The parameter “TopDeckToTopGirderWeb” shown in Figure 73, not only defines the haunch or build-up thickness for all of the deck sections, it is

also important as the insertion point for all of the girders on the project. This provides an excellent example of how the concept of parametric modeling is meant to be used.

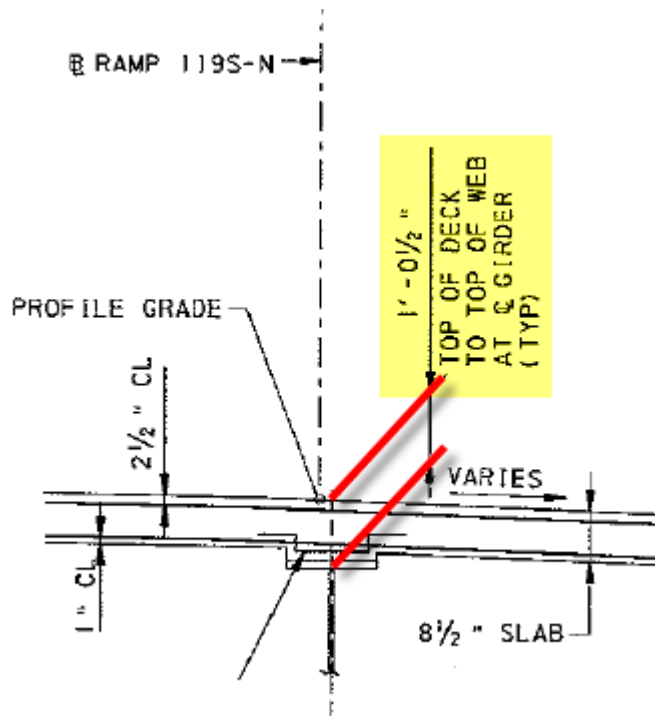

Figure 73 - Ramp 119 S-N Deck/Girder Key Parameter

## 6.4.2 Example Girder Section

Girders are also defined in reference to the alignment. A portion of the framing plan is shown in Figure 74, and a partial girder elevation in Figure 75. The starting point for the girders is 1'-1" before Abutment 1 centerline bearing station 61+25.00, or an X-coordinate of 73,487". The horizontal offset from the HCL to Girder 1 is 9'-9" to the right, or a Y-coordinate of -117". The insertion point of the girder library object is defined as the top of the web, so the Z-coordinate is -12.5" from the PGL.

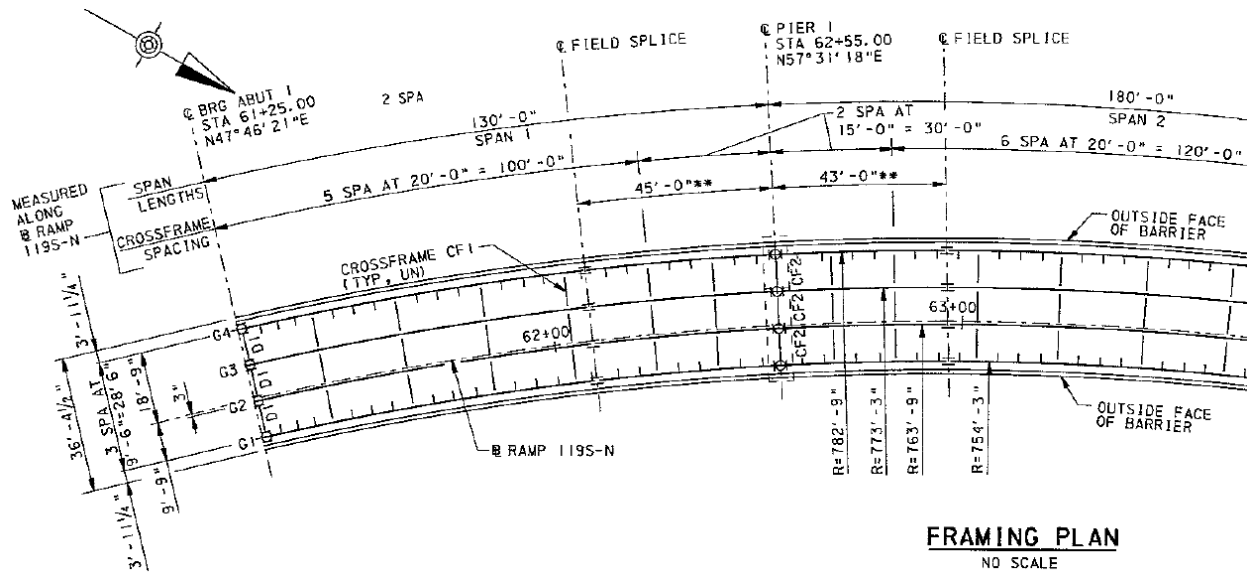

Figure 74 - Ramp 119 S-N Girder Framing Plan

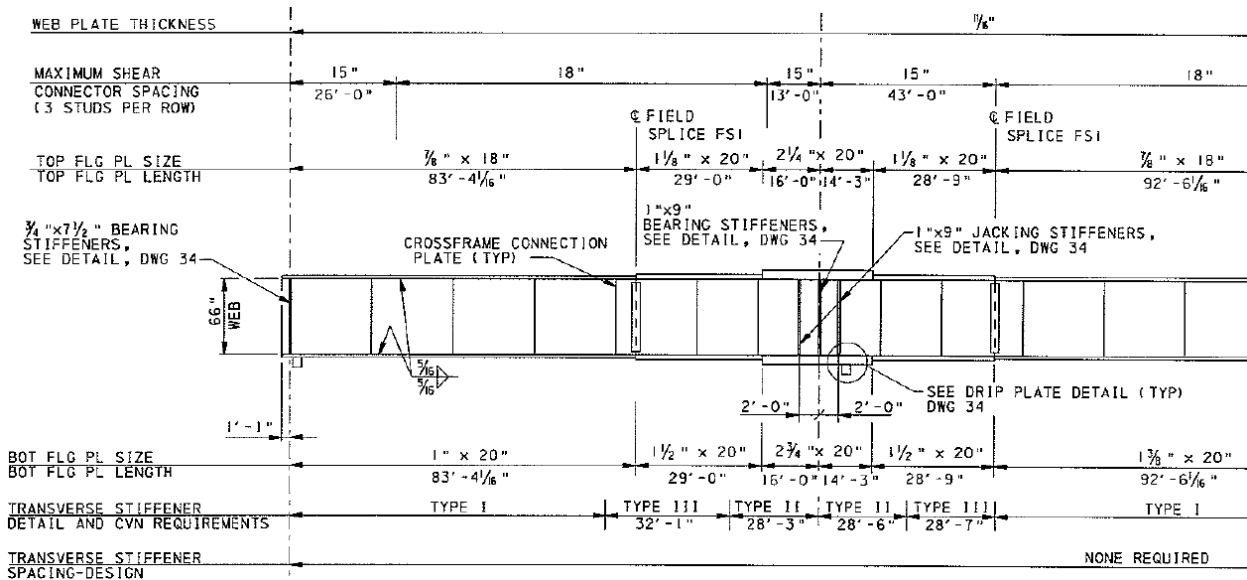

Figure 75 - Ramp 119 S-N Girder 1 Elevation

Girder 1 field section 1 is 130'-0" less 45'-0" from centerline bearing of Abutment 1, making the overall length of the piece 86'-1" or 1,033". Since the girder follows both the HCL and PGL, but is oriented so that the web is vertical its AlignH and AlignV parameters are set to "Warp", and the AlignT parameter is set to "None". The ParamML code required to position and orient this girder section (stiffeners omitted for clarity) is as follows:

```

<O N="Superstructure" T="Group">
  <O N="Girders" T="Group">
    <P N="Color" V="#991111" T="Text" />
    <P N="Opacity" V="0.7" />
    <O N="Girder 1" T="Group">
      <O N="G1FS1" T="SteelGirderMB" Z="-12.5" Y="117" X="BridgeLayoutData.Abut1Sta-13"
AlignV="Warp" AlignH="Warp" AlignT="None">

```

```

<P N="StartStation" V="G1FS1.X" />
<P N="Offset" V="G1FS1.Y" />
<P N="Length" V="1033" />
<P N="dw" V="66" D="Web depth of the I girder" />
<P N="tw" V="0.6875" D="Web thickness of the I girder" />
<P N="bft" V="18" D="Width of the top flange of the I girder" />
<P N="tft" V="0.875" D="Thickness of the top flange of the I girder" />
<P N="bfb" V="20" D="Width of the bottom flange of the I girder" />
<P N="tfb" V="1" D="Thickness of the bottom flange of the I girder" />
</O>
</O>
</O>
</O>

```

Girder 1 field section 1, this time including the stiffeners, is shown in Figure 76.

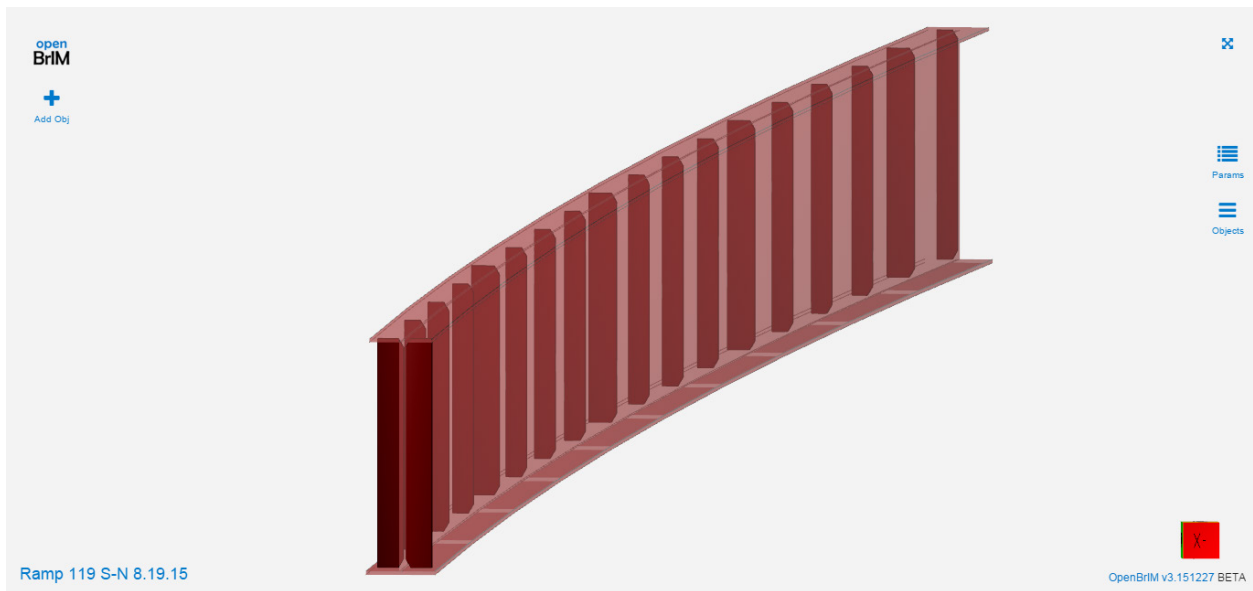

Figure 76 - Ramp 119 S-N Girder 1 Field Section 1

Figure 77 shows the connectivity of the girder to the deck.

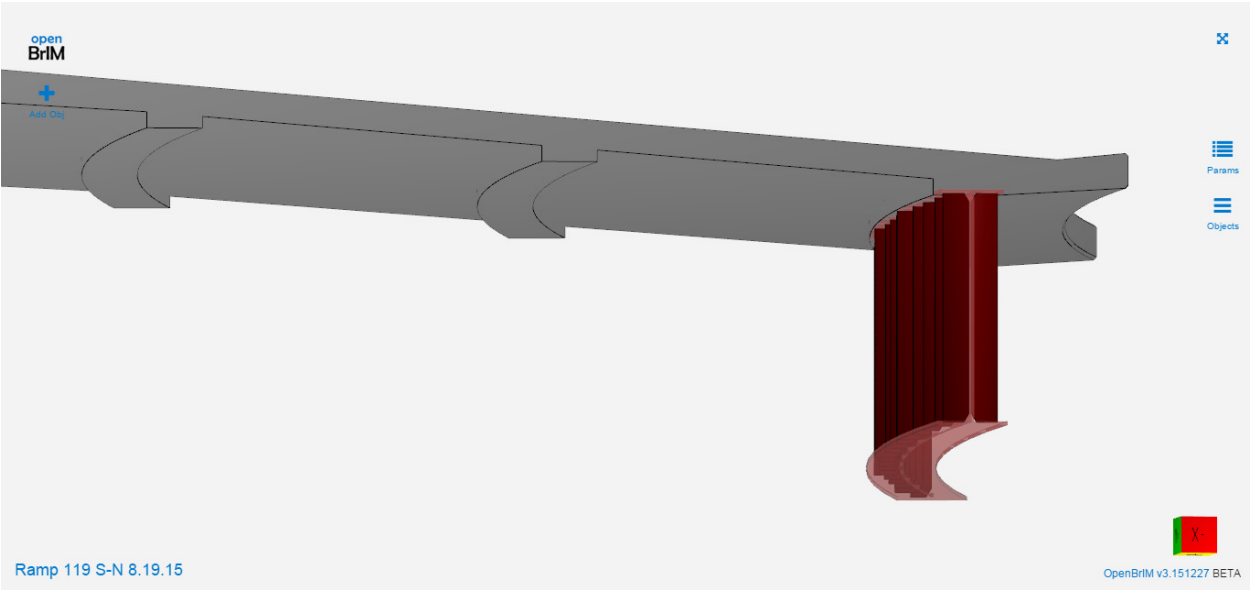

Figure 77- Ramp 119 S-N Girder/Deck Interface

### 6.4.3 Example Cross Frame

The cross frames are the other major component of a steel bridge superstructure. Ramp 119 S-N cross frame configuration based on workpoints from the girders, is shown in Figure 78.

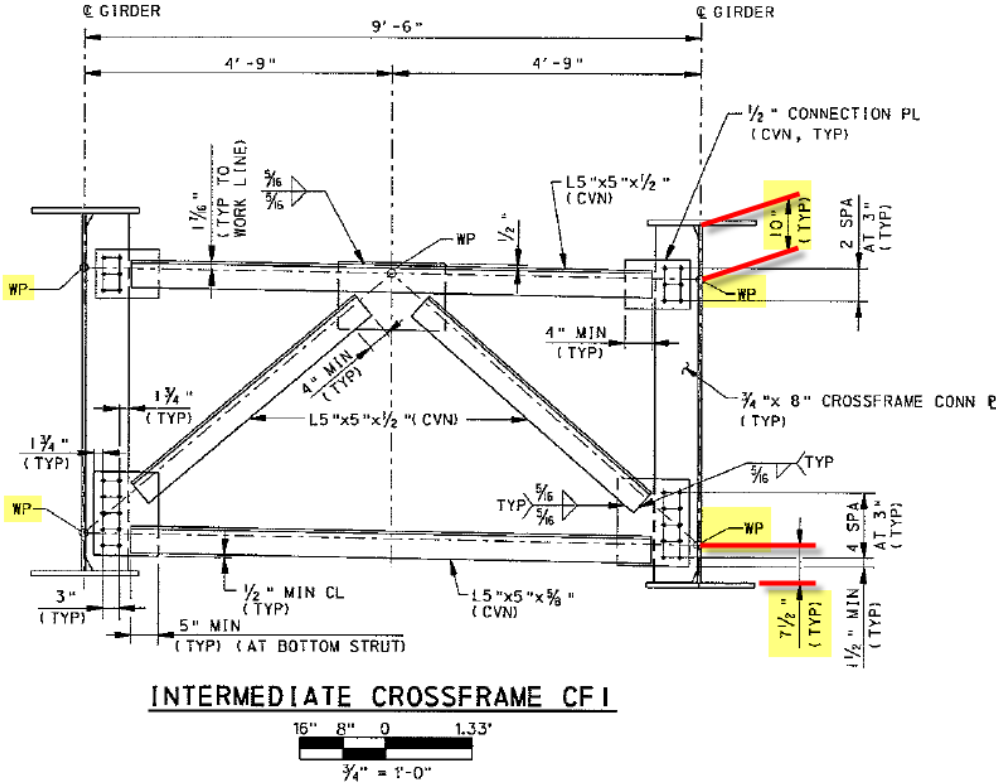

Figure 78 - Ramp 119 S-N Cross Frame

The top chords have workpoints 10" below the previously defined girder workpoint at the top of the web. The bottom workpoints are 7.5" above the 66" constant depth web. The configuration of the library object was described in Section 5.5.5.8. Because the workpoints are referenced to the girders, which are referenced from the deck, it allows the changing roadway cross section geometry to be accounted for automatically in the positioning of the cross frames. The girder horizontal offsets from the HCL provide the parameters for transverse position. Longitudinally, the cross frames are positioned at the connection stiffeners of the girders, corrected by the stiffener plate thickness. Cross frames are located longitudinally by distance from the starting reference, which is the Abutment 1 station. The ParamML code in the project file (neglecting the gusset plate data for clarity) to generate all cross frames in one bay is as follows:

```
<O N="CrossFrames" T="Group">
  <O N="CF1" T="Group">
    <O N="Bay1" T="CrossFrameLayout" X="Abut1Sta-(ConnStiffT+thickness)/2">
      <P N="CrossFrameType" V="CrossFrameTypeKTop" T="Text" />
      <P N="CrossFrameLocations" V="[240,480,720,960,1200,1380,1740,1920,2160,2400,2640,
        2880,3120,3360,3540,3900,4080,4380,4680,4980]" />
      <P N="StartStation" V="Bay1.X" />
      <P N="GirderA_Horiz_Offset" V="GirderOffset[1]" D="Girder A (Left) CL Offset from HCL" />
      <P N="GirderB_Horiz_Offset" V="GirderOffset[0]" D="Girder B (Right) CL Offset from HCL" />
      <P N="WebDepth" V="66" />
      <P N="TopWP_Vert_Offset" V="10" D="Top Work Point offset from top of Girder web" />
      <P N="TopWP_Horiz_Offset" V="0" D="Top Work Point offset from CL of Girder web" />
      <P N="BotWP_Vert_Offset" V="7.5" D="Bottom Work Point offset from bottom of Girder web" />
      <P N="BotWP_Horiz_Offset" V="0" D="Bottom Work Point offset from CL of Girder web" />
      <P N="BoltDia" V="0.75" D="Diameter of bolt" />
      <P N="EdgeDist" V="1.75" D="Distance from edge of Plate to CL of Bolt Hole" />
      <P N="ConnStiffT" V="0.75" D="Connector Stiffener Thickness" />
      <O N="Cross Frame Member Data" T="Group">
        <P N="TopChord" V="L5X5X1over2" T="Section" />
        <P N="BotChord" V="L5X5X1over2" T="Section" />
        <P N="Diagonal" V="L5X5X1over2" T="Section" />
      </O>
    </O>
  </O>
</O>
```

A view of the cross frame is shown in Figure 79. Note that in the ParamML code, there are no Align parameters in the project code for this more complex object. Because the corner gusset plates remain normal to the girders, but the top center gusset plate follows the slope of the top chord, those individual elements have their own Align parameter requirements, which must be contained within the library object code. Because of the roadway section has variations in cross slope across the width, Girders 3 and 4 do not have the same vertical elevation difference as Girders 1 and 2 and Girders 2 and 3. The cross frame library object takes into account the variation as can be seen in Figure 80.

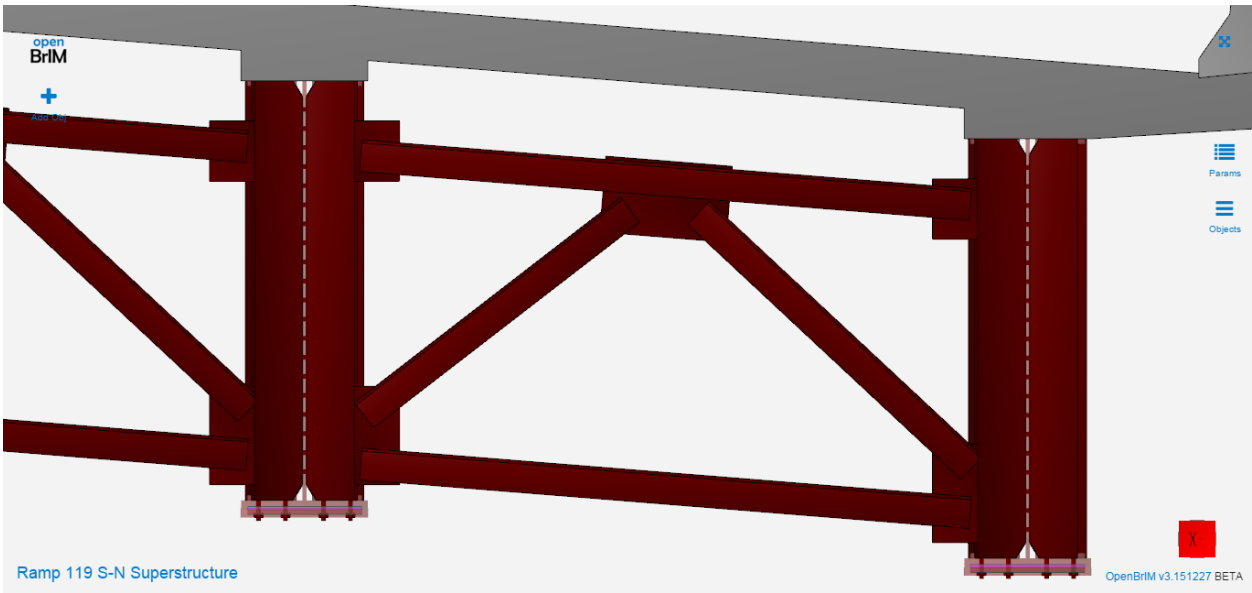

Figure 79 - Ramp 119 S-N Cross Frame Racking

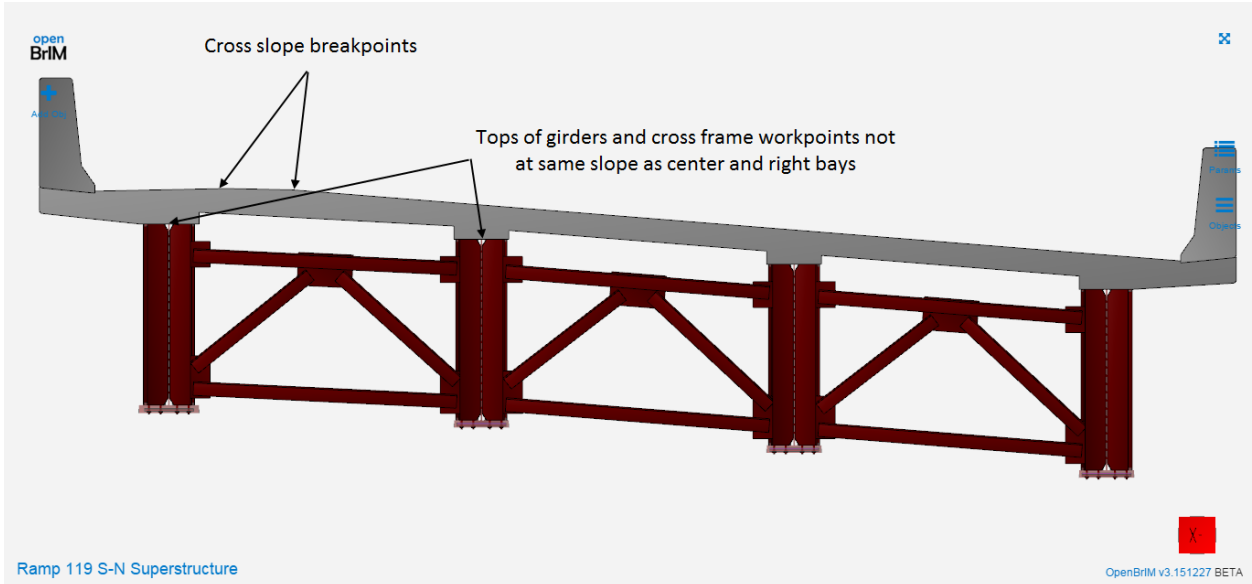

Figure 80- Ramp 119 S-N Cross Frame Variations





# Section 7 – Gaps

Development of OpenBrIM is still in the early stages. This work was intended to define and document the definitions of some of the most common bridge objects and test the feasibility of using the OpenBrIM approach in modeling representative bridge types. Although a number of bridge component library templates have been established, there are many more that need to be developed. Some of the gaps in component objects are:

- Accommodating skew
- Incorporating girder structural cambers and construction deformations
- Incorporating steel girder cross frame drops for no-load, steel dead load, and total load conditions
- Welding details
- Steel reinforcing bar bend details to incorporate standard hooks, etc.
- Additional development of standard precast concrete components
- Pretensioning and Post-Tensioning details
- Additional bearing types
- Expansion Joints
- Drainage components
- Lighting, signs and utility attachment components
- Architectural treatment such as inset surface patterns and details on components
- Digital terrain modeling of site work to represent existing and future ground contours

Non-graphical information gaps include:

- Metadata storage for geotechnical (soil borings) and hydraulic reports
- Metadata storage for as-constructed details, inspection reporting, scheduled maintenance, and repairs for Asset Management, and durability monitoring

Probably the biggest gap in the OpenBrIM concept is in defining how the system will be owned, implemented, and maintained.



# Section 8 – Industry Outreach

A key component of the project scope of work included industry outreach in the form of the following webinars, conference presentations, and workshops.

- 2015 AASHTO SCOBST-19 presentation, Saratoga Springs, NY, April 20, 2015
- Standardization of Bridge Information Modeling (BrIM) Webinar, April 27, 2015
- 2015 Cooperative Agreement Annual Meeting, Bethlehem, PA, May 28, 2015
- IBC Workshop – Bridge Information Modeling (BrIM) Standardization & Interoperability, Pittsburgh, PA, June 11, 2015
- FHWA Bridge Information Modeling (BrIM) Workshop, Washington, DC, August 25-26, 2015

The first three of these were primarily informational presentations, where material about the OpenBrIM and NIBS projects were given. The first workshop held at the International Bridge Conference also included several presentations and perspectives from the project teams, owners, and industry trade organizations.

Most of the development of the OpenBrIM standard library objects and the example bridge model were completed prior to the formal FHWA Bridge Information Modeling (BrIM) Workshop in Washington, DC. During the workshop, the OpenBrIM concept and the current building standards using the Industry Foundations Class (IFC) concept were presented to a group of approximately 35 bridge community representatives from FHWA, AASHTO, industry trade organizations, academia, contractors, consultants, and software vendors. The goal of the workshop was to help build consensus for an open standards based approach for Bridge Information Modeling. While the workshop generated a lot of discussion on the merits of two different approaches, it may have created more questions than answers on the path forward. This report is focused on the findings of the OpenBrIM approach.

Some of the key questions, comments, concerns, and discussion from the DC workshop participants are as follows:

1. Steel fabricators want to use 3-D BrIM models to eliminate the need for shop drawings.
2. There is a concern over liability when electronic data files take the place of 2-D paper drawings.
3. Contracting and procurement will require changes to procedures.
4. Data is needed to show cost savings and/or return on investment (ROI) when moving to BrIM technology.
5. Qualitative examples and case studies are needed to educate public sector DOT's in the use of BrIM.
6. Can this technology be extended for identifying utility interferences, and how is that data obtained and incorporated into models?
7. How can rehabilitations/widenings of existing bridges be handled, and what is the level of work required to model an existing bridge?
8. How can BrIM data be made available and separated from software that produces models?
9. How is compatibility and version control ensured between OpenBrIM objects that are created by many different authors? Objects are extendable in OpenBrIM, meaning they can be copied into a new user's library and modified to suit the new user's preferences. These modifications cannot be changed by anyone else.

10. An open format library concept will need oversight and QA/QC.
11. How are OpenBrIM library objects certified/validated? The library has a section for discussions. Objects go through a development and discussion phases prior to becoming a standard. All development is overseen by a committee, which needs to be defined.
12. Do Owners have the desire to create a library of their own digital definition of objects?
13. States want to leverage what other industries are doing. What is standard to one state is not common to others.
14. Is an “open” library really what is needed? More openness requires more governance, and who will govern OpenBrIM?
15. Should an AASHTO committee be created for vetting the certification process for OpenBrIM?
16. What can be done to incorporate both OpenBrIM and IFC? Are they compatible? Open BrIM is a great platform to test and determine data requirements. OpenBrIM is a way to conceptualize objects that can then become part of an IFC standard.
17. Software vendors need to step back to listen to the Owners/practitioners.
18. How would software vendors convert to OpenBrIM?
19. Original goal of OpenBrIM was to create a central repository of objects that could be used to eliminate exchanges.

Future work on OpenBrIM development will need to focus on addressing the above questions. Work to date has been in the discovery mode, which often develops additional questions and issues to solve.

# Section 9 - Conclusions

## 9.1 Advantages of OpenBrIM

There are several very advantageous features of the OpenBrIM approach.

- OpenBrIM places the responsibility of standards development in the good hands of the bridge community, thus its slogan “Community Driven Bridge Information Modeling”. This creates an opportunity for the actual users of the information to define the data necessary for the standard bridge components they are the most knowledgeable about, instead of having a software programmer who may have little connection to the bridge industry develop the standards.
- OpenBrIM makes use of centralized on-cloud data storage for individual bridge models and the library of component standards. The bridge model data is accessible to all authorized users for a particular project. This eliminates the need for physical file exchange, at least initially.
- OpenBrIM offers complete independence from any local software installation. The program gains enormous flexibility by providing information through the internationally accepted XML standard, requiring only minimal hardware resources with a web browser connected to the internet. For example, a conference room computer could quickly access a model during a meeting, or an inspector could verify a bridge component in the field with their smartphone.
- OpenBrIM is based on ParamML, an XML derivative, which uses a text based format. Bridge component objects and their data parameters are given common English language names and descriptors, allowing them to be readily understood by a large group of users. These names can be developed to correspond with common bridge industry terminology. Standards can also be developed in other languages for use internationally.
- The ability to review, manipulate, and build projects in OpenBrIM without having extensive knowledge of programming or ability to read computer code will significantly facilitate adoption of this standard by the broader bridge design and construction community.
- Bridge component library objects are defined parametrically, allowing repeated use for similar components by varying the geometric and/or physical property data. Common data can be defined globally within a project and automatically update all affected objects. For example, the industry standard workpoint for a steel I-girder bridge is the top of web at the centerline of the girder. That workpoint is a constant distance below the roadway surface elevation. In addition to defining the steel girder geometry, it controls the depth of the concrete deck haunch, and it's the control point used in defining cross-frame geometry. Using that control location in girder, deck, and cross-frame objects assures that all of those components are synchronized to retain their connectivity when the parameter's dimension is modified.
- The OpenBrIM library of bridge component standards are open to everyone. This promotes collaboration within the industry to develop new objects based on already developed standards. For example, as part of this project, a versatile steel bridge K-type cross frame object was developed. When another user needs to define an X-type cross frame, he or she can start with the available K-type cross frame as a guide.

There are also some challenges to implement the OpenBrIM system.

- OpenBrIM will require some type of organizational board to be the steward for the overall system. This includes ownership and maintenance of the centralized data repositories, and moderating the standards development process. Thus far, these issues have only been identified. There will be costs

with an on-cloud server system that will require a funding source. There will likely be a significant amount of discussion and cooperation necessary to come to agreement on how such an organization will operate.

- While there are approximately 30 or more OpenBrIM bridge component library objects available, they are in various stages of development. To date, there are none that are considered to be fully developed standards for use. All of the objects lack steel reinforcement. Promoting OpenBrIM will require a more complete library of standard component objects to be developed to show the robustness of the concept. OpenBrIM is still essentially in Beta testing mode and not fully production ready.
- While we have extensively developed and tested compilation of library objects in project files through ParamML coding, more development and experimentation is needed with similar project construction through the user interface. It may continue to be a challenge to provide quick load times for projects that contain increasing levels of detail and complexity.

## 9.2 Next Steps

The first thing that must happen for OpenBrIM to become a viable solution is to address some of the gaps identified in Section 7. The most significant gap that absolutely has to be addressed is the incorporation of reinforcing and pre- and post-tensioning steel into the concrete components. Those capabilities now exist within OpenBrIM, but were developed too late to incorporate into this report. Digital terrain modeling of the existing and proposed ground surfaces is also necessary for developing a complete 3-D representation of a project. Finally, expansion joint components will need to be developed.

Further validation of the OpenBrIM approach will likely require that it be implemented on a pilot test project for a state Department of Transportation. There is probably little incentive for a state to do this with a system that is not production ready. However, there are several sources for funding available through the following FHWA programs that may be considered to further develop OpenBrIM:

- Accelerated Innovation Deployment (AID) Funding
- State Transportation Innovation Council (STIC) Incentive Funds
- MAP-21 Section 1304 Innovative Project Delivery Funding

Once one or more example bridge projects are modeled in OpenBrIM, the next step would be to make presentations at AASHTO SCOBS and other bridge oriented national and regional conferences to promote its use.

## 9.3 Concluding Remarks

OpenBrIM is a powerful open, parametric approach with ability to model any bridge component conceivable and standardize to support detailing practices for individual owners. Further development of OpenBrIM as one approach for bridge information modeling should be continued until such time that owners and industry can achieve consensus. If the next steps outlined above can be followed, the power of OpenBrIM will be demonstrated, which will allow it to gain the momentum necessary to obtain broader implementation by the bridge community.

There is however, the possibility that the building industry IFC system may be the choice of the bridge community for standardization. If that is the case, there may be an opportunity to merge the two systems. The IFC data structure could become the exchange standard and OpenBrIM, with its logical interface could be used to develop bridge component objects and libraries. Recently, OpenBrIM developed the capability of creating an IFC format file for any library object that it creates.

## Appendix A – Library Object Definitions





# Pile (BB)

open BrIM Pile (BB) BY BENJAMIN BLASSEN

Refresh Params

d Depth	10	bf Flange width	10.25	tf Flange Thickness	0.5625
tw Web Thickness	0.5625	fillet Fillet Radius	0.5	L Length	300
Batter Slope H v	$\frac{3}{12} = 0.25$	Phi Batter Orientation	0	Beta Web Orientation	0

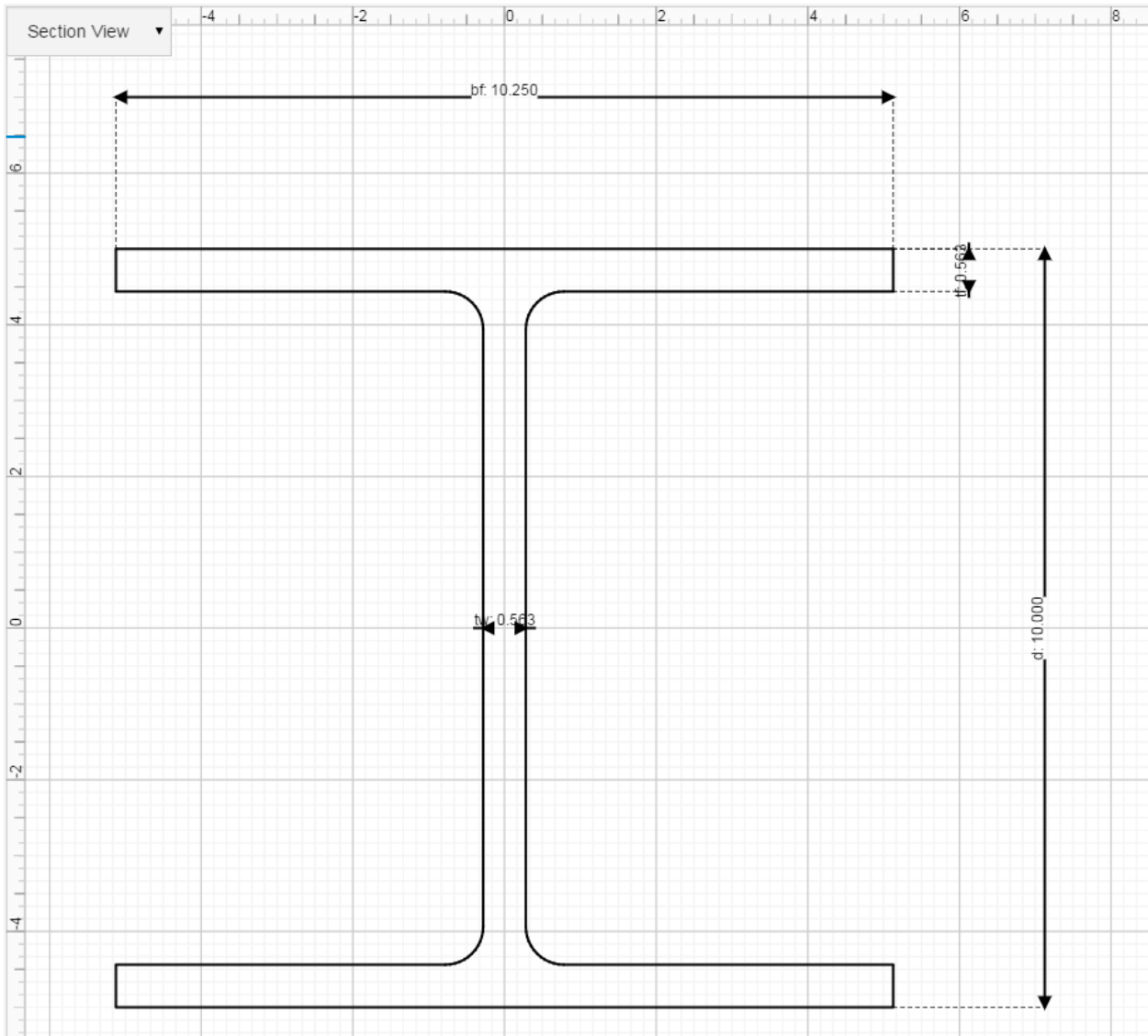

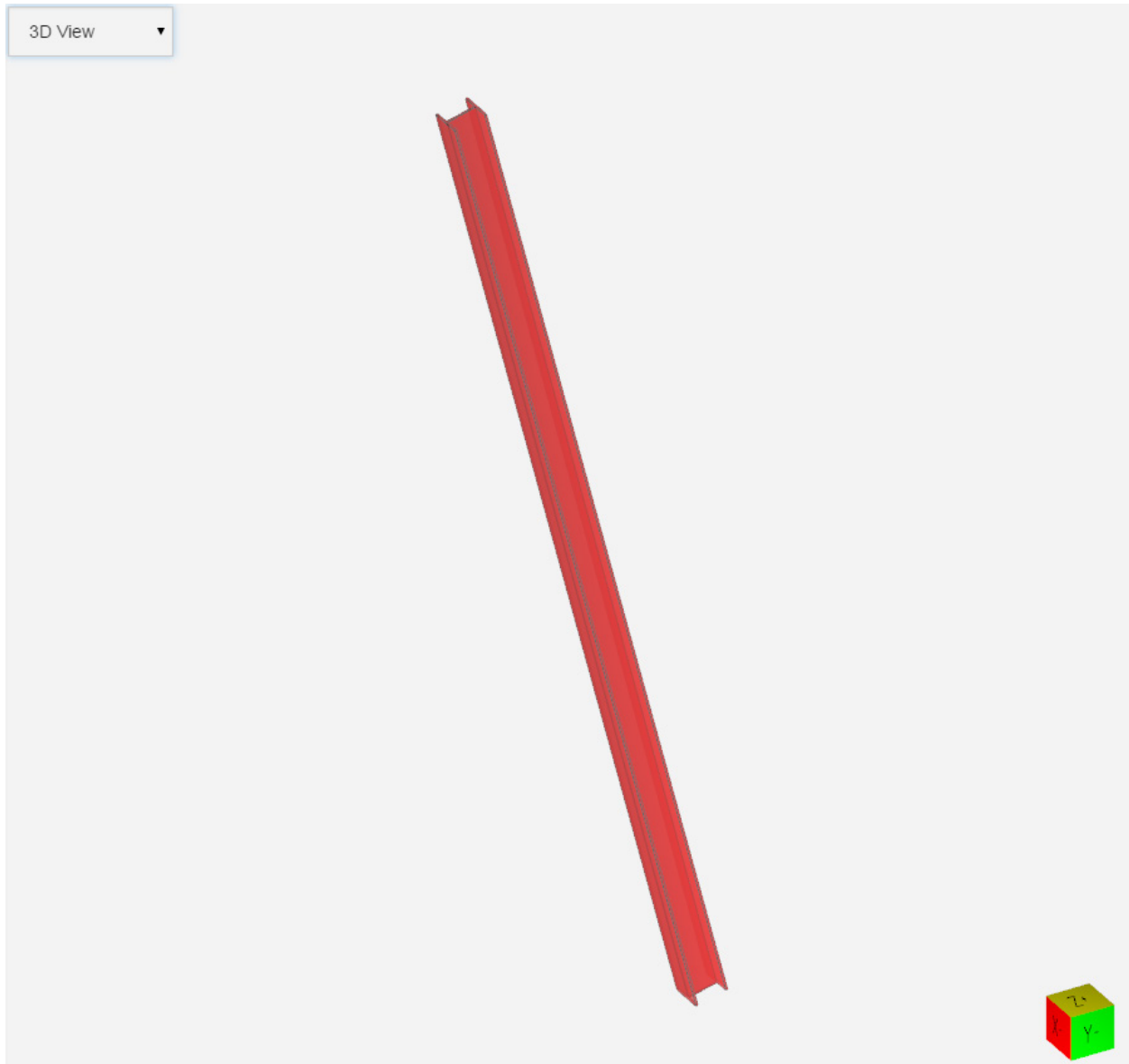

ParamML Code

```

<O N="Pile (BB)" T="Project">
  <P N="d" V="10" D="Depth" Role="Input" />
  <P N="bf" V="10.25" D="Flange width" Role="Input" />
  <P N="tf" V="0.5625" D="Flange Thickness" Role="Input" />
  <P N="tw" V="0.5625" D="Web Thickness" Role="Input" />
  <P N="fillet" V="0.5" D="Fillet Radius" Role="Input" />
  <P N="L" V="300" D="Length" Role="Input" />
  <P N="Batter" V="3/12" D="Batter Slope H:V" Role="Input" />
  <P N="Phi" V="0" D="Batter Orientation" Role="Input" />
  <P N="Beta" V="0" D="Web Orientation" Role="Input" />
  <P N="PileSection" V="H-Pile Section" T="Section" />
  <O N="ObjDesc" T="Group">
    <!--<p> |Pile (BB)| library object.</p>-->
    <!-- <i>Created by <b>Mike Bartholomew</b> on 6/2/2015 -->
    <!-- Updated by <b>Benjamin Blasen</b> on 8/12/2015</i> -->
  
```

```

<!--
-->
</O>
<O N="H-Pile Section" T="Section">
  <O T="Point" X="-bf/2" Y="d/2" />
  <O T="Point" X="bf/2" Y="d/2" />
  <O T="Point" X="bf/2" Y="d/2-tf" />
  <O T="Point" X="tw/2" Y="d/2-tf" />
  <O T="Point" X="tw/2" Y="-d/2+tf" />
  <O T="Point" X="bf/2" Y="-d/2+tf" />
  <O T="Point" X="bf/2" Y="-d/2" />
  <O T="Point" X="-bf/2" Y="-d/2" />
  <O T="Point" X="-bf/2" Y="-d/2+tf" />
  <O T="Point" X="-tw/2" Y="-d/2+tf" />
  <O T="Point" X="-tw/2" Y="d/2-tf" />
  <O T="Point" X="bf/2" Y="d/2-tf" />
</O>
<O T="Volume">
  <P N="Color" V="ff0000" T="Text" />
  <P N="Opacity" V="0.75" />
  <P N="BetaAngle" V="Beta" />
  <P N="Section" V="PileSection" T="Section" />
  <O T="Point" Y="0" Z="0" X="0" />
  <O T="Point" Y="L*sin(Phi)*sin(Batter)" Z="-L*cos(Batter)" X="L*sin(Batter)*cos(Phi)" />
</O>
<O N="Section View" T="CADD">
  <P N="margin" V="1" />
  <O T="CADDShape" Y="0" X="0" RZ="Phi">
    <P N="Color" V="rgb(0, 0, 0)" T="Text" />
    <P N="Thickness" V="2" />
    <P N="IsClosed" V="T" T="Text" />
    <O T="Point" X="-bf/2" Y="d/2" />
    <O T="Point" X="bf/2" Y="d/2" />
    <O T="Point" X="bf/2" Y="d/2-tf" />
    <O T="Point" X="tw/2" Y="d/2-tf" R="fillet" />
    <O T="Point" X="tw/2" Y="-d/2+tf" R="fillet" />
    <O T="Point" X="bf/2" Y="-d/2+tf" />
    <O T="Point" X="bf/2" Y="-d/2" />
    <O T="Point" X="-bf/2" Y="-d/2" />
    <O T="Point" X="-bf/2" Y="-d/2+tf" />
    <O T="Point" X="-tw/2" Y="-d/2+tf" R="fillet" />
    <O T="Point" X="-tw/2" Y="d/2-tf" R="fillet" />
    <O T="Point" X="bf/2" Y="d/2-tf" />
  </O>
  <O T="CADDDimensionLine" Y="0" X="0" RZ="Phi">
    <P N="Label" V="d: %d" T="Text" />
    <O T="Point" Y="-d/2" X="bf/2" />
    <O T="Point" Y="d/2" X="bf/2" />
    <O T="Point" Y="0" X="bf/2+2*margin" />
  </O>
  <O T="CADDDimensionLine" Y="0" X="0" RZ="Phi">
    <P N="Label" V="tw: %d" T="Text" />
    <O T="Point" Y="0" X="-tw/2" />
    <O T="Point" Y="0" X="tw/2" />
    <O T="Point" Y="0" X="0" />
  </O>

```

```
</O>  
<O T="CADDDimensionLine" Y="0" X="0" RZ="Phi">  
  <P N="Label" V="tf: %d" T="Text" />  
  <O T="Point" Y="d/2-tf" X="bf/2" />  
  <O T="Point" Y="d/2" X="bf/2" />  
  <O T="Point" Y="0" X="bf/2+margin" />  
</O>  
<O T="CADDDimensionLine" Y="0" X="0" RZ="Phi">  
  <P N="Label" V="bf: %d" T="Text" />  
  <O T="Point" Y="d/2" X="-bf/2" />  
  <O T="Point" Y="d/2" X="bf/2" />  
  <O T="Point" Y="d/2+2*margin" X="0" />  
</O>  
</O>  
</O>
```

## Abutment U-Shaped Footing

open  
BrIM **Abutment U-Shaped Footing** BY MIRA BARTHOLDIEN

Refresh Params ▾

Length Footing Length (Transverse to Bridge Alignment)	484.5	Width Footing Width (Along Bridge Alignment)	108	WWA_Length Footing Length (Transverse to Bridge Alignment)	384
WWA_Width Footing Width (Along Bridge Alignment)	108	WWB_Length Footing Length (Transverse to Bridge Alignment)	324	WWB_Width Footing Width (Along Bridge Alignment)	108
Depth Footing Depth	30	BotElev Footing Bottom Elevation	0	CL_Bearing CL Bearing to Front Edge of Footing	42
HCL_Offset HCL to Left Edge of Footing	188.25				

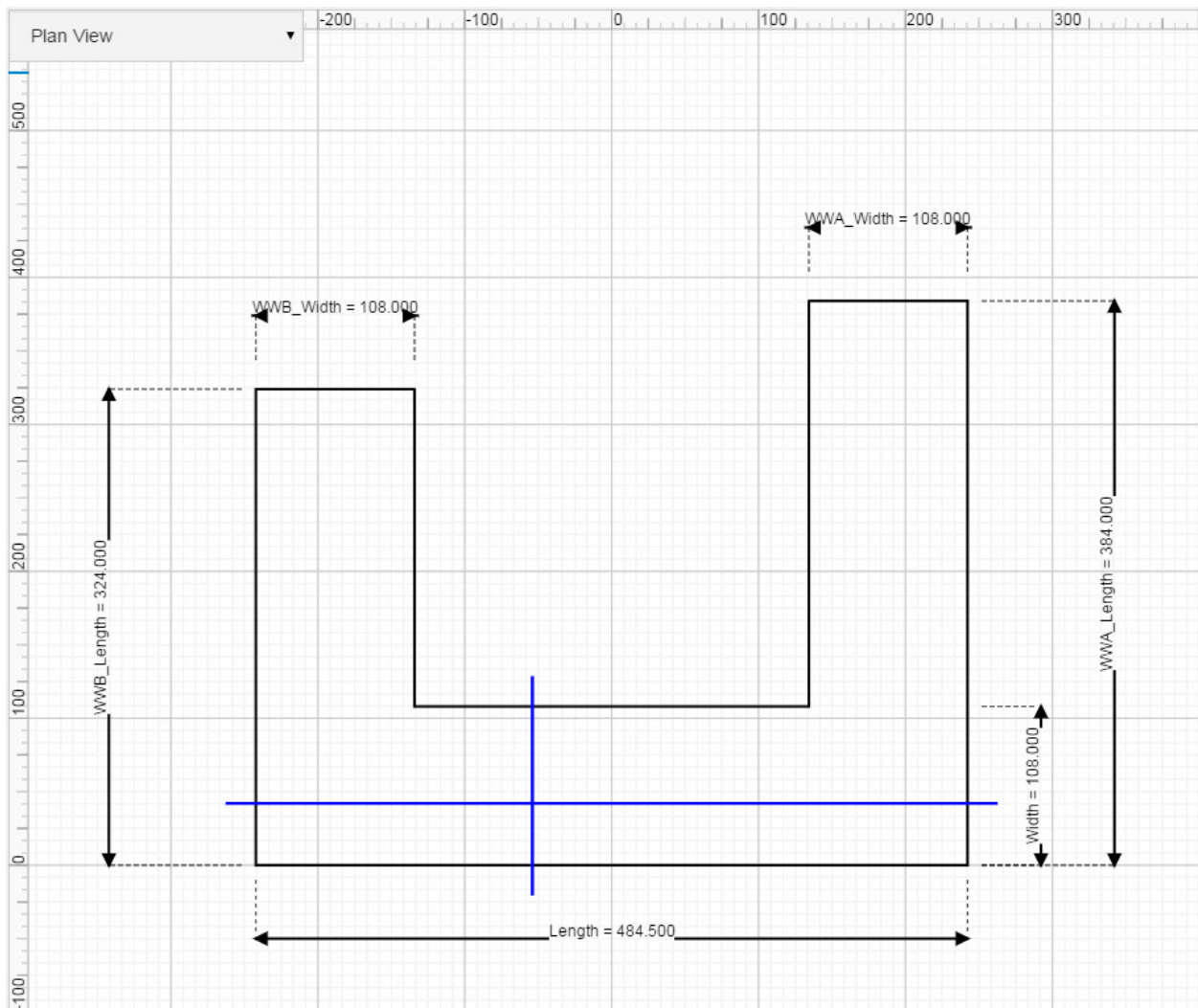

ParamML Code

```

<O N="Abutment U-Shaped Footing" T="Project">
  <P N="Length" V="484.5" D="Footing Length (Transverse to Bridge Alignment)" Role="Input" />
  <P N="Width" V="108" D="Footing Width (Along Bridge Alignment)" Role="Input" />
  <P N="WWA_Length" V="384" D="Footing Length (Transverse to Bridge Alignment)" Role="Input" />
  <P N="WWA_Width" V="108" D="Footing Width (Along Bridge Alignment)" Role="Input" />
  <P N="WWB_Length" V="324" D="Footing Length (Transverse to Bridge Alignment)" Role="Input" />
  <P N="WWB_Width" V="108" D="Footing Width (Along Bridge Alignment)" Role="Input" />
  <P N="Depth" V="30" D="Footing Depth" Role="Input" />
  <P N="BotElev" V="0" D="Footing Bottom Elevation" Role="Input" />
  <P N="CL_Bearing" V="42" D="CL Bearing to Front Edge of Footing" Role="Input" />
  <P N="HCL_Offset" V="188.25" D="HCL to Left Edge of Footing" Role="Input" />
  <!-- created by Mike Bartholomew on 6/18/2015 -->
  <O T="Surface" Z="BotElev">
    <P N="Thickness" V="Depth" />
    <O T="Point" X="-HCL_Offset" Y="-CL_Bearing" />
    <O T="Point" X="Length-HCL_Offset" Y="-CL_Bearing" />
    <O T="Point" X="Length-HCL_Offset" Y="WWA_Length-CL_Bearing" />
    <O T="Point" X="Length-HCL_Offset-WWA_Width" Y="WWA_Length-CL_Bearing" />
    <O T="Point" X="Length-HCL_Offset-WWA_Width" Y="Width-CL_Bearing" />
    <O T="Point" X="-HCL_Offset+WWB_Width" Y="Width-CL_Bearing" />
    <O T="Point" X="-HCL_Offset+WWB_Width" Y="WWB_Length-CL_Bearing" />
    <O T="Point" X="-HCL_Offset" Y="WWB_Length-CL_Bearing" />
  </O>
  <O N="Plan View" T="CADD">
    <P N="margin" V="10" />
    <O T="CADDShape" Y="0" X="0" RZ="0">
      <P N="Color" V="rgb(0, 0, 0)" T="Text" />
      <P N="Thickness" V="2" />
      <P N="IsClosed" V="T" T="Text" />
      <O T="Point" X="-Length/2" Y="0" />
      <O T="Point" X="Length/2" Y="0" />
      <O T="Point" X="Length/2" Y="WWA_Length" />
      <O T="Point" X="Length/2-WWA_Width" Y="WWA_Length" />
      <O T="Point" X="Length/2-WWA_Width" Y="Width" />
      <O T="Point" X="-Length/2+WWB_Width" Y="Width" />
      <O T="Point" X="-Length/2+WWB_Width" Y="WWB_Length" />
      <O T="Point" X="-Length/2" Y="WWB_Length" />
    </O>
    <O T="CADDShape" Y="0" X="0" RZ="0">
      <P N="Color" V="rgb(0, 0, 999)" T="Text" />
      <P N="Thickness" V="2" />
      <P N="IsClosed" V="F" T="Text" />
      <O T="Point" X="-54" Y="0-2*margin" />
      <O T="Point" X="-54" Y="Width+2*margin" />
    </O>
    <O T="CADDShape" Y="0" X="0" RZ="0">
      <P N="Color" V="rgb(0, 0, 999)" T="Text" />
      <P N="Thickness" V="2" />
      <P N="IsClosed" V="F" T="Text" />
      <O T="Point" X="-Length/2-2*margin" Y="42" />
      <O T="Point" X="Length/2+2*margin" Y="42" />
    </O>
    <O T="CADDDimensionLine" Y="0" X="0" RZ="0">
      <P N="Label" V="Length = %d" T="Text" />
      <O T="Point" X="-Length/2" Y="-margin" />
      <O T="Point" X="Length/2" Y="-margin" />
      <O T="Point" X="0" Y="-5*margin" />
    </O>
    <O T="CADDDimensionLine" Y="0" X="0" RZ="0">
      <P N="Label" V="Width = %d" T="Text" />

```

```

<O T="Point" X="Length/2+margin" Y="0" />
<O T="Point" X="Length/2+margin" Y="Width" />
<O T="Point" X="Length/2+5*margin" Y="Width/2" />
</O>
<O T="CADDDimensionLine" Y="0" X="0" RZ="0">
  <P N="Label" V="WWA_Length = %d" T="Text" />
  <O T="Point" X="Length/2+margin" Y="0" />
  <O T="Point" X="Length/2+margin" Y="WWA_Length" />
  <O T="Point" X="Length/2+10*margin" Y="WWA_Length" />
</O>
<O T="CADDDimensionLine" Y="0" X="0" RZ="0">
  <P N="Label" V="WWA_Width = %d" T="Text" />
  <O T="Point" X="Length/2-WWA_Width" Y="WWA_Length+2*margin" />
  <O T="Point" X="Length/2" Y="WWA_Length+2*margin" />
  <O T="Point" X="Length/2" Y="WWA_Length+5*margin" />
</O>
<O T="CADDDimensionLine" Y="0" X="0" RZ="0">
  <P N="Label" V="WWB_Length = %d" T="Text" />
  <O T="Point" X="-Length/2-margin" Y="0" />
  <O T="Point" X="-Length/2-margin" Y="WWB_Length" />
  <O T="Point" X="-Length/2-10*margin" Y="WWB_Length" />
</O>
<O T="CADDDimensionLine" Y="0" X="0" RZ="0">
  <P N="Label" V="WWB_Width = %d" T="Text" />
  <O T="Point" X="-Length/2" Y="WWB_Length+2*margin" />
  <O T="Point" X="-Length/2+WWB_Width" Y="WWB_Length+2*margin" />
  <O T="Point" X="Length/2" Y="WWB_Length+5*margin" />
</O>
</O>
<O N="Longitudinal Elevation View" T="CADD">
  <P N="margin" V="2" />
  <O T="CADDShape" Y="0" X="0" RZ="0">
    <P N="Color" V="rgb(0, 0, 0)" T="Text" />
    <P N="Thickness" V="2" />
    <P N="IsClosed" V="T" T="Text" />
    <O T="Point" X="-Length/2" Y="BotElev" />
    <O T="Point" X="Length/2" Y="BotElev" />
    <O T="Point" X="Length/2" Y="Depth" />
    <O T="Point" X="-Length/2" Y="Depth" />
  </O>
  <O T="CADDDimensionLine" Y="0" X="0" RZ="0">
    <P N="Label" V="Length = %d" T="Text" />
    <O T="Point" X="-Length/2" Y="Depth+margin" />
    <O T="Point" X="Length/2" Y="Depth+margin" />
    <O T="Point" X="Length/2" Y="Depth+5*margin" />
  </O>
  <O T="CADDDimensionLine" Y="0" X="0" RZ="0">
    <P N="Label" V="Depth = %d" T="Text" />
    <O T="Point" X="Length/2+margin" Y="BotElev" />
    <O T="Point" X="Length/2+margin" Y="BotElev+Depth" />
    <O T="Point" X="Length/2+10*margin" Y="0" />
  </O>
</O>
</O>
</O>

```

**Stem Abutment (BB)**

[Stem Abutment (BB)] library object is central object of compiling associated abutment objects. Other abutment objects that are related include [Abutment Backwall 2], [ConcPedestal (BB)], [Pot Bearing], [Footing], [Stem Wall (BB)], [Cheekwall], [Pile (BB)], and [Wing Wall (BB)]. The library object includes placement of pedestals; independent placement of pedestals can be accomplished by setting PedestalDepth[0] and PedestalLocations1[0]. The stem height (StemH) is set at centerline and the top slope of the stem varies about centerline based on the "PedSlope" parameter.

open BrIM Stem Abutment (BB) BY BENJAMIN BLASEN

Refresh PedestalData

<b>PedestalTopWidth</b> Top Width of the Girder Supports 36	<b>PedestalBotWidth</b> Bottom Width of the Girder Supports 46	<b>PedestalL1</b> Length of Girder Support 1 36
<b>PedestalDepth</b> Depth of Girder Supports [0, 6, 4, 2]	<b>PedestalLocations1</b> Location of Pedestal set 1 from CL Abut [- 171, - 57, 57, 171]	<b>PedestalOffset1</b> Location of girder support set 1 from CL Cap 0

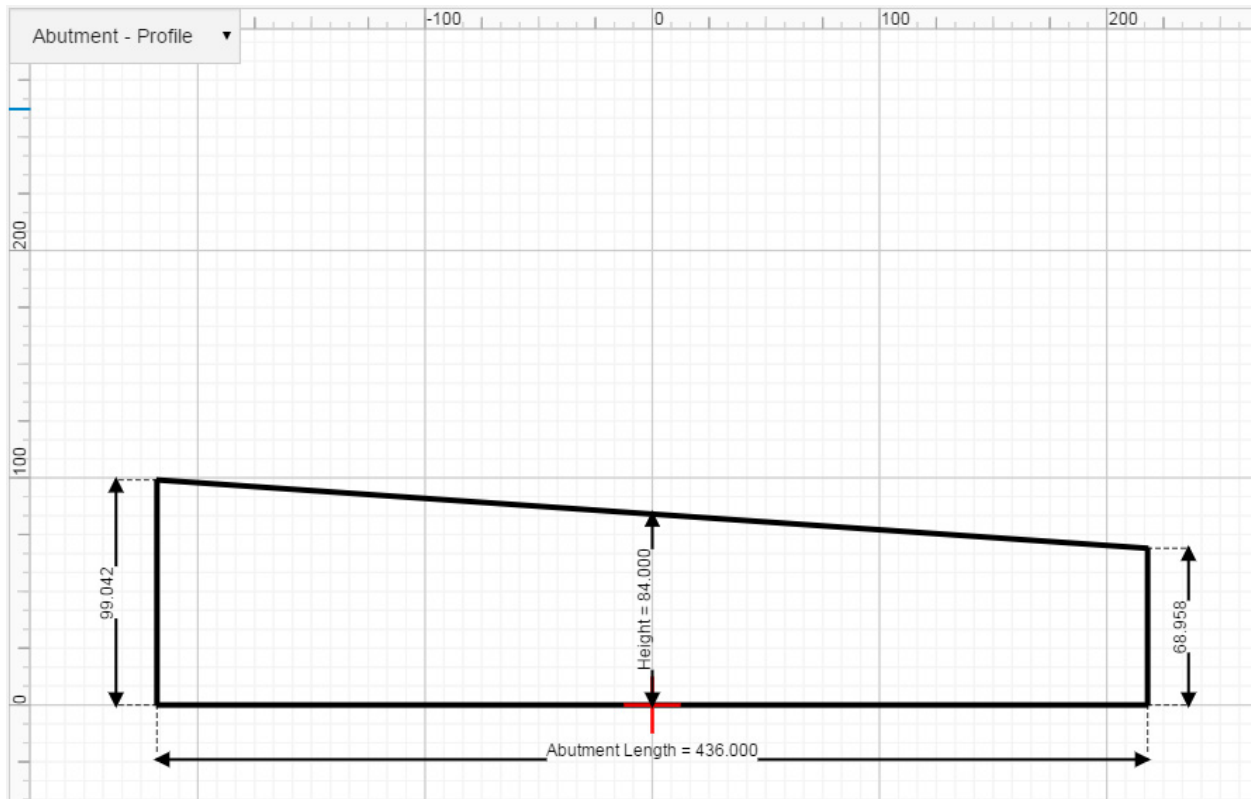



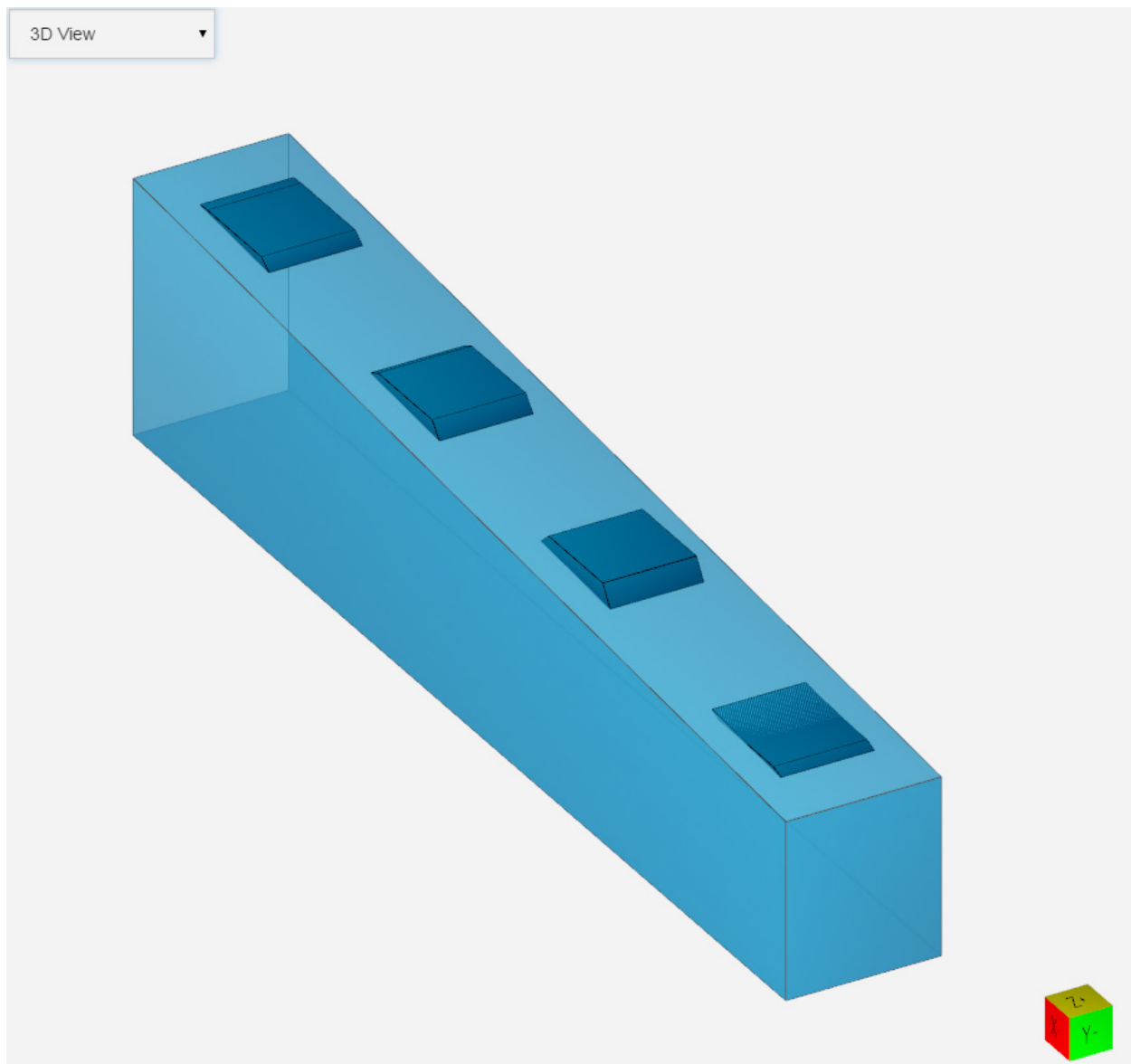

### ParamML Code

```

<O N="Stem Abutment (BB)" T="Project">
  <P N="Color" V="#00B2EE" T="Text" />
  <P N="Opacity" V="0.8" />
  <O N="ObjDesc" T="Group">
    <!--<p> |Stem Abutment (BB)| library object is central object of compiling associated
      abutment objects. Other abutment objects that are related include |Abutment Backwall 2|, |ConcPedestal
(BB)|
      , |Pot Bearing|, |Footing|, |Stem Wall (BB)|, |Cheekwall|, |Pile (BB)|, and |Wing Wall (BB)|.
      The library object includes placement of pedestals; independent placement of pedestals can be
      accomplished by setting PedestalDepth[0] and PedestalLocations1[0].</p>
      <p>
      The stem height (StemH) is set at centerline and the top slope of the stem varies about
      centerline based on the "PedSlope" parameter.
      </p-->
    <!-- <i>created by <b>Alex Harrison</b> on 6/8/2015</i> -->
    <!-- <i>updated by <b>Mike Bartholomew</b> on 6/18/2015</i> -->
    <!-- <i>updated by <b>Benjamin Blasen</b> on 7/8/2015</i> -->
  </O>
</O>

```

```

<!--
-->
</O>
<O N="AbutData" T="Group">
  <P N="AbutLength" V="436" D="Total Abut Length" Role="Input" Category="AbutData" UT="Length"
UC="Properties" />
  <P N="StemWidth" V="60" D="Abut Width" Role="Input" Category="AbutData" UT="Length" UC="Properties"
/>
  <P N="PedSlope" V="0.069" D="Slope of surface for pedestal mounts" Role="Input" Category="AbutData"
UT="Length" UC="Properties" />
  <P N="BackWallHeight" V="85" D="" Role="Input" Category="AbutData" UT="Length" UC="Properties" />
  <P N="BackWallThick" V="24" D="" Role="Input" Category="AbutData" UT="Length" UC="Properties" />
  <P N="BackWallNotchH" V="9" D="" Role="Input" Category="AbutData" UT="Length" UC="Properties" />
  <P N="BackWallNotchV" V="20" D="" Role="Input" Category="AbutData" UT="Length" UC="Properties" />
  <P N="StemH" V="84" D="Min Depth at Center" Role="Input" Category="AbutData" UT="Length"
UC="Properties" />
</O>
<O N="PedestalData" T="Group">
  <P N="PedestalTopWidth" V="36" D="Top Width of the Girder Supports" Role="Input"
Category="PedestalData" UT="Length" UC="Properties" />
  <P N="PedestalBotWidth" V="46" D="Bottom Width of the Girder Supports" Role="Input"
Category="PedestalData" UT="Length" UC="Properties" />
  <P N="PedestalL1" V="36" D="Length of Girder Support 1" Role="Input" Category="PedestalData" UT="Length"
UC="Properties" />
  <P N="PedestalDepth" V="[0,6,4,2]" D="Depth of Girder Supports" Role="Input" Category="PedestalData"
UT="Length" UC="Properties" />
  <P N="PedestalLocations1" V="[-171, -57, 57, 171]" D="Location of Pedestal set 1 from CL Abut" Role="Input"
Category="PedestalData" UT="Length" UC="Properties" />
  <P N="PedestalOffset1" V="0" D="Location of girder support set 1 from CL Cap" Role="Input"
Category="PedestalData" UT="Length" UC="Properties" />
</O>
<O T="Volume">
  <O N="A" T="Surface">
    <O T="Point" X="-StemWidth/2" Z="-(AbutLength/2)*PedSlope" Y="-AbutLength/2" />
    <O T="Point" X="StemWidth/2" Z="-(AbutLength/2)*PedSlope" Y="-AbutLength/2" />
    <O T="Point" X="StemWidth/2" Z="-StemH" Y="-AbutLength/2" />
    <O T="Point" X="-StemWidth/2" Z="-StemH" Y="-AbutLength/2" />
  </O>
  <O N="B" T="Surface">
    <O T="Point" X="-StemWidth/2" Z="(AbutLength/2)*PedSlope" Y="AbutLength/2" />
    <O T="Point" X="StemWidth/2" Z="(AbutLength/2)*PedSlope" Y="AbutLength/2" />
    <O T="Point" X="StemWidth/2" Z="-StemH" Y="AbutLength/2" />
    <O T="Point" X="-StemWidth/2" Z="-StemH" Y="AbutLength/2" />
  </O>
</O>
<O T="Group">
  <P N="Guard" V="PedestalL1.GT.0" />
  <O T="Repeat">
    <P N="S" V="0" />
    <P N="E" V="length(PedestalLocations1)" />
    <P N="I" V="1" />
    <P N="CTRL" V="hnl" T="Text" />
    <P N="hnl" V="0" />
  </O>
  <O T="Group">
    <P N="Guard" V="hnl.GT.0" />

```

```

    <O T="Group">
      <O N="GirdSupport" T="ConcPedestal (BB)" Z="PedestalLocations1[hnl-1]*PedSlope"
Y="PedestalLocations1[hnl-1]">
        <P N="SupportSlope" V="PedSlope" D="T" />
        <P N="SupportTopWidth" V="PedestalTopWidth" />
        <P N="SupportBotWidth" V="PedestalBotWidth" />
        <P N="SupportL" V="PedestalL1" />
        <P N="PedestalOffset" V="PedestalOffset1" />
        <P N="SupportDepth" V="PedestalDepth[hnl-1]" />
      </O>
    </O>
  </O>
</O>
<O N="Abutment - Profile" T="CADD">
  <P N="margin" V="6" />
  <O T="CADDShape">
    <P N="Color" V="rgb(0, 0, 0)" T="Text" />
    <P N="Thickness" V="4" />
    <P N="IsClosed" V="T" T="Text" />
    <O T="Point" X="0" Y="0" />
    <O T="Point" X="-AbutLength/2" Y="0" />
    <O T="Point" X="-AbutLength/2" Y="StemH+PedSlope*AbutLength/2" />
    <O T="Point" X="0" Y="StemH" />
    <O T="Point" X="AbutLength/2" Y="StemH-PedSlope*AbutLength/2" />
    <O T="Point" X="AbutLength/2" Y="0" />
  </O>
  <O T="CADDLine">
    <P N="Color" V="#FF0000" T="Text" />
    <P N="Thickness" V="2" />
    <O T="Point" X="0" Y="-12" />
    <O T="Point" X="0" Y="12" />
  </O>
  <O T="CADDLine">
    <P N="Color" V="#FF0000" T="Text" />
    <P N="Thickness" V="2" />
    <O T="Point" X="12" Y="0" />
    <O T="Point" X="-12" Y="0" />
  </O>
  <O T="CADDDimensionLine" Y="0" X="0" RZ="0">
    <P N="Label" V="Abutment Length = %d" T="Text" />
    <O T="Point" Y="0" X="-AbutLength/2" />
    <O T="Point" Y="0" X="AbutLength/2" />
    <O T="Point" Y="-margin*4" X="0" />
  </O>
  <O T="CADDDimensionLine" Y="0" X="0" RZ="0">
    <P N="Label" V="%d" T="Text" />
    <O T="Point" Y="0" X="-AbutLength/2" />
    <O T="Point" Y="StemH+PedSlope*AbutLength/2" X="-AbutLength/2" />
    <O T="Point" Y="0" X="-AbutLength/2-margin*3" />
  </O>
  <O T="CADDDimensionLine" Y="0" X="0" RZ="0">
    <P N="Label" V="%d" T="Text" />
    <O T="Point" Y="0" X="AbutLength/2" />
    <O T="Point" Y="StemH-PedSlope*AbutLength/2" X="AbutLength/2" />
    <O T="Point" Y="0" X="AbutLength/2+margin*3" />
  </O>

```

```
</O>  
<O T="CADDDimensionLine" Y="0" X="0" RZ="0">  
  <P N="Label" V="Height = %d" T="Text" />  
  <O T="Point" Y="0" X="0" />  
  <O T="Point" Y="StemH" X="0" />  
  <O T="Point" Y="0" X="0" />  
</O>  
</O>  
</O>
```

### Abutment Backwall 2

[Abutment Backwall] library object is meant to be placed on top of [Stem Abutment (BB)] library object. This object has the option of a notch which can be limited on either end by a left stub and right stub. The bottom of the backwall can follow a straight pedestal slope from the stem. The top of the backwall can warp to follow the transverse contour of the roadway.

If the top of the backwall is warping to the roadway, it is important to achieve the correct adjustment of the bottom points of the backwall through the use of the 'ADJ' factors; these factors are automated for a backwall which is centered on the centerline of the roadway, but require adjustment for their y-position if used otherwise. Additionally, the station parameter "S1" and orientation parameter "ADJside" are used for this adjustment and can be neglected when the warp is not being used.

open BrIM Abutment Backwall 2 BY BENJAMIN BLASEN

Refresh AbutData

AbutLength Total Abut Length, in.	436	StemWidth Abutment Width, in.	60	BackWallHeight Back Wall Height, in.	85
BackWallThick Back Wall Thickness, in.	24	BackWallNotchH Back Wall Notch Thickness, in.	9	BackWallNotchV Back Wall Notch Height, in.	20
stubL Length of Left Stub in Back Wall (from cutout), in.	20	stubR Length of Right Stub in Back Wall (from cutout), in.	20	PedSlope Slope of surface for pedestal mounts	0.069



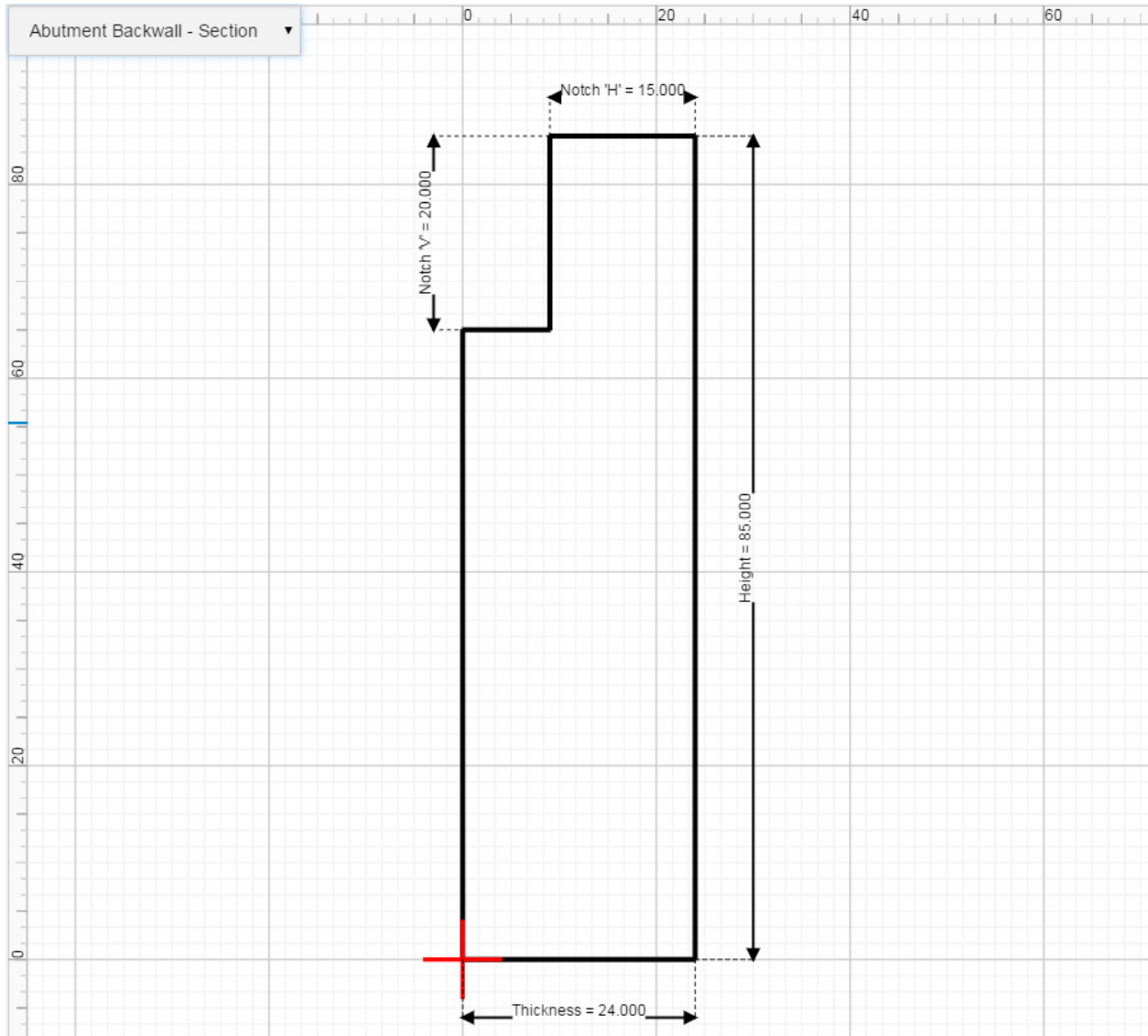

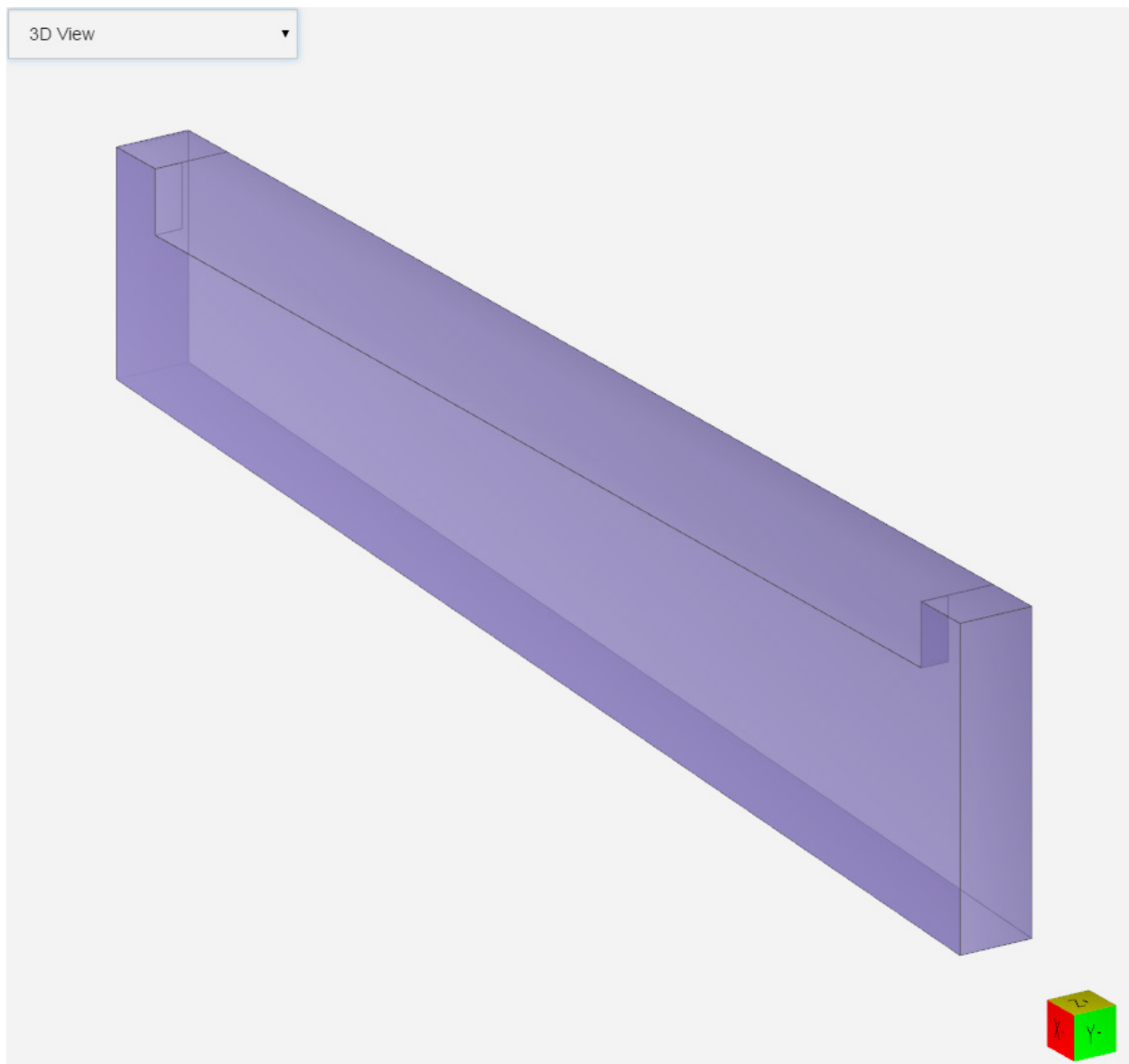

### ParamML Code

```

<O N="Abutment Backwall 2" T="Project">
  <P N="Color" V="#9988DD" T="Text" />
  <P N="Opacity" V="0.8" />
  <O N="ObjDesc" T="Group">
    <!--<p> |Abutment Backwall| library object is meant to be placed on top of
    |Stem Abutment (BB)| library object. This object has the option of a notch which
    can be limited on either end by a left stub and right stub. The bottom of the backwall
    can follow a straight pedestal slope from the stem. The top of the backwall can warp to
    follow the transverse contour of the roadway. </p>
    <p>
    If the top of the backwall is warping to the roadway, it is important to achieve the
    correct adjustment of the bottom points of the backwall through the use of the 'ADJ' factors;
    these factors are automated for a backwall which is centered on the centerline of the roadway,
    but require adjustment for their y-position if used otherwise. Additionally, the station
    parameter "S1" and orientation parameter "ADJside" are used for this adjustment and can be
    neglected when the warp is not being used.
    </p-->
  </O>
</O>

```

```

<!-- <i>created by <b>Benjamin Blasen</b> on 7/17/2015</i> -->
<!--

-->
</O>
<O N="AbutData" T="Group">
  <P N="AbutLength" V="436" D="Total Abut Length, in." Role="Input" Category="AbutData" UT="Length" UC="Properties" />
  <P N="StemWidth" V="60" D="Abutment Width, in." Role="Input" Category="AbutData" UT="Length" UC="Properties" />
  <P N="BackWallHeight" V="85" D="Back Wall Height, in." Role="Input" Category="AbutData" UT="Length" UC="Properties"
/>
  <P N="BackWallThick" V="24" D="Back Wall Thickness, in." Role="Input" Category="AbutData" UT="Length"
UC="Properties" />
  <P N="BackWallNotchH" V="9" D="Back Wall Notch Thickness, in." Role="Input" Category="AbutData" UT="Length"
UC="Properties" />
  <P N="BackWallNotchV" V="20" D="Back Wall Notch Height, in." Role="Input" Category="AbutData" UT="Length"
UC="Properties" />
  <P N="stubL" V="20" D="Length of Left Stub in Back Wall (from cutout), in." Role="Input" Category="AbutData"
UT="Length" UC="Properties" />
  <P N="stubR" V="20" D="Length of Right Stub in Back Wall (from cutout), in." Role="Input" Category="AbutData"
UT="Length" UC="Properties" />
  <P N="PedSlope" V="0.069" D="Slope of surface for pedestal mounts" Role="Input" Category="AbutData" UT="Length"
UC="Properties" />
  <P N="S1" V="0" />
  <P N="ADJside" V="1" D="Determines the appropriate side for the vertical adjustment based on whether the backwall is
facing forward on station (1) or back on station (-1)." />
  <P N="ADJLF" V="-alignT(Alignment, S1-StemWidth/2+BackWallThick, -AbutLength/2*ADJside)" D="Adjustment needed on
the left side of the start haunch" />
  <P N="ADJRF" V="-alignT(Alignment, S1-StemWidth/2+BackWallThick, AbutLength/2*ADJside)" D="Adjustment needed on
the right side of the start haunch" />
  <P N="ADJLB" V="-alignT(Alignment, S1-StemWidth/2, -AbutLength/2*ADJside)" D="Adjustment needed on the left side of
the start haunch" />
  <P N="ADJRB" V="-alignT(Alignment, S1-StemWidth/2, AbutLength/2*ADJside)" D="Adjustment needed on the right side of
the start haunch" />
  <P N="ADJLM" V="-alignT(Alignment, S1-StemWidth/2+BackWallNotchH, -AbutLength/2*ADJside)" D="Adjustment needed
on the left side of the start haunch" />
  <P N="ADJRM" V="-alignT(Alignment, S1-StemWidth/2+BackWallNotchH, AbutLength/2*ADJside)" D="Adjustment needed
on the right side of the start haunch" />
</O>
<O T="Volume" AlignH="Warp" AlignT="Warp">
  <O T="Surface" X="-StemWidth/2">
    <P N="SegmentsAround" V="1" />
    <P N="SegmentsAlong" V="1" />
    <O T="Point" X="0" Z="PedSlope*AbutLength/2-ADJLF" Y="-AbutLength/2" AlignTB="0" />
    <O T="Point" X="0" Z="BackWallHeight-BackWallNotchV" Y="-AbutLength/2">
      <P N="Guard" V="stubL.EQ.0" />
    </O>
    <O T="Point" X="0" Z="BackWallHeight" Y="-AbutLength/2">
      <P N="Guard" V="stubL.NE.0" />
    </O>
    <O T="Point" X="0" Z="BackWallHeight" Y="-AbutLength/2+stubL">
      <P N="Guard" V="stubL.NE.0" />
    </O>
    <O T="Point" X="0" Z="BackWallHeight-BackWallNotchV" Y="-AbutLength/2+stubL" />
    <O T="Point" X="0" Z="BackWallHeight-BackWallNotchV" Y="AbutLength/2-stubR" />
    <O T="Point" X="0" Z="BackWallHeight" Y="AbutLength/2-stubR">
      <P N="Guard" V="stubR.NE.0" />
    </O>
    <O T="Point" X="0" Z="BackWallHeight" Y="AbutLength/2">
      <P N="Guard" V="stubR.NE.0" />
    </O>
    <O T="Point" X="0" Z="BackWallHeight-BackWallNotchV" Y="AbutLength/2">
      <P N="Guard" V="stubR.EQ.0" />
    </O>
  </O>
</O>

```



```

</O>
<O T="Point" X="0" Z="-PedSlope*AbutLength/2-ADJRF" Y="AbutLength/2" AlignTB="0" />
</O>
<O T="Surface" X="-StemWidth/2+BackWallNotchH">
  <P N="SegmentsAround" V="1" />
  <P N="SegmentsAlong" V="1" />
  <O T="Point" X="0" Z="PedSlope*AbutLength/2-ADJLM" Y="-AbutLength/2" AlignTB="0" />
  <O T="Point" X="0" Z="BackWallHeight-BackWallNotchV" Y="-AbutLength/2">
    <P N="Guard" V="stubL.EQ.0" />
  </O>
  <O T="Point" X="0" Z="BackWallHeight" Y="-AbutLength/2">
    <P N="Guard" V="stubL.NE.0" />
  </O>
  <O T="Point" X="0" Z="BackWallHeight" Y="-AbutLength/2+stubL">
    <P N="Guard" V="stubL.NE.0" />
  </O>
  <O T="Point" X="0" Z="BackWallHeight-BackWallNotchV" Y="-AbutLength/2+stubL" />
  <O T="Point" X="0" Z="BackWallHeight-BackWallNotchV" Y="AbutLength/2-stubR" />
  <O T="Point" X="0" Z="BackWallHeight" Y="AbutLength/2-stubR">
    <P N="Guard" V="stubR.NE.0" />
  </O>
  <O T="Point" X="0" Z="BackWallHeight" Y="AbutLength/2">
    <P N="Guard" V="stubR.NE.0" />
  </O>
  <O T="Point" X="0" Z="BackWallHeight-BackWallNotchV" Y="AbutLength/2">
    <P N="Guard" V="stubR.EQ.0" />
  </O>
  <O T="Point" X="0" Z="-PedSlope*AbutLength/2-ADJRM" Y="AbutLength/2" AlignTB="0" />
</O>
<O T="Surface" X="-StemWidth/2+BackWallNotchH">
  <P N="SegmentsAround" V="1" />
  <P N="SegmentsAlong" V="1" />
  <P N="Thickness" V="-BackWallThick+BackWallNotchH" />
  <O T="Point" X="0" Z="PedSlope*AbutLength/2-ADJLM" Y="-AbutLength/2" AlignTB="0" />
  <O T="Point" X="0" Z="BackWallHeight" Y="-AbutLength/2">
    <P N="Guard" V="stubL.EQ.0" />
  </O>
  <O T="Point" X="0" Z="BackWallHeight" Y="-AbutLength/2">
    <P N="Guard" V="stubL.NE.0" />
  </O>
  <O T="Point" X="0" Z="BackWallHeight" Y="-AbutLength/2+stubL">
    <P N="Guard" V="stubL.NE.0" />
  </O>
  <O T="Point" X="0" Z="BackWallHeight" Y="-AbutLength/2+stubL" />
  <O T="Point" X="0" Z="BackWallHeight" Y="AbutLength/2-stubR" />
  <O T="Point" X="0" Z="BackWallHeight" Y="AbutLength/2-stubR">
    <P N="Guard" V="stubR.NE.0" />
  </O>
  <O T="Point" X="0" Z="BackWallHeight" Y="AbutLength/2">
    <P N="Guard" V="stubR.NE.0" />
  </O>
  <O T="Point" X="0" Z="BackWallHeight" Y="AbutLength/2">
    <P N="Guard" V="stubR.EQ.0" />
  </O>
  <O T="Point" X="0" Z="-PedSlope*AbutLength/2-ADJRM" Y="AbutLength/2" AlignTB="0" />
</O>
<O T="Surface" X="-StemWidth/2+BackWallThick">
  <P N="SegmentsAround" V="1" />
  <P N="SegmentsAlong" V="1" />
  <O T="Point" X="0" Z="PedSlope*AbutLength/2-ADJLB" Y="-AbutLength/2" AlignTB="0" />
  <O T="Point" X="0" Z="BackWallHeight" Y="-AbutLength/2">
    <P N="Guard" V="stubL.EQ.0" />
  </O>

```

```

</O>
<O T="Point" X="0" Z="BackWallHeight" Y="-AbutLength/2">
  <P N="Guard" V="stubL.NE.0" />
</O>
<O T="Point" X="0" Z="BackWallHeight" Y="-AbutLength/2+stubL">
  <P N="Guard" V="stubL.NE.0" />
</O>
<O T="Point" X="0" Z="BackWallHeight" Y="-AbutLength/2+stubL" />
<O T="Point" X="0" Z="BackWallHeight" Y="AbutLength/2-stubR" />
<O T="Point" X="0" Z="BackWallHeight" Y="AbutLength/2-stubR">
  <P N="Guard" V="stubR.NE.0" />
</O>
<O T="Point" X="0" Z="BackWallHeight" Y="AbutLength/2">
  <P N="Guard" V="stubR.NE.0" />
</O>
<O T="Point" X="0" Z="BackWallHeight" Y="AbutLength/2">
  <P N="Guard" V="stubR.EQ.0" />
</O>
<O T="Point" X="0" Z="-PedSlope*AbutLength/2-ADJRB" Y="AbutLength/2" AlignTB="0" />
</O>
</O>
<O N="Abutment Backwall - Profile" T="CADD">
  <P N="margin" V="6" />
  <O T="CADDShape">
    <P N="Color" V="rgb(0, 0, 0)" T="Text" />
    <P N="Thickness" V="4" />
    <P N="IsClosed" V="T" T="Text" />
    <O T="Point" Y="PedSlope*AbutLength/2" X="-AbutLength/2" AlignTB="0" />
    <O T="Point" Y="BackWallHeight-BackWallNotchV" X="-AbutLength/2">
      <P N="Guard" V="stubL.EQ.0" />
    </O>
    <O T="Point" Y="BackWallHeight" X="-AbutLength/2">
      <P N="Guard" V="stubL.NE.0" />
    </O>
    <O T="Point" Y="BackWallHeight" X="-AbutLength/2+stubL">
      <P N="Guard" V="stubL.NE.0" />
    </O>
    <O T="Point" Y="BackWallHeight-BackWallNotchV" X="-AbutLength/2+stubL" />
    <O T="Point" Y="BackWallHeight-BackWallNotchV" X="AbutLength/2-stubR" />
    <O T="Point" Y="BackWallHeight" X="AbutLength/2-stubR">
      <P N="Guard" V="stubR.NE.0" />
    </O>
    <O T="Point" Y="BackWallHeight" X="AbutLength/2">
      <P N="Guard" V="stubR.NE.0" />
    </O>
    <O T="Point" Y="BackWallHeight-BackWallNotchV" X="AbutLength/2">
      <P N="Guard" V="stubR.EQ.0" />
    </O>
    <O T="Point" Y="-PedSlope*AbutLength/2" X="AbutLength/2" AlignTB="0" />
  </O>
</O>
<O T="CADDLine">
  <P N="Thickness" V="3" />
  <O T="Point" X="-AbutLength/2+stubL" Y="BackWallHeight" />
  <O T="Point" X="AbutLength/2-stubR" Y="BackWallHeight" />
</O>
<O T="CADDLine">
  <P N="Color" V="#FF0000" T="Text" />
  <P N="Thickness" V="2" />
  <O T="Point" X="0" Y="-12" />
  <O T="Point" X="0" Y="12" />
</O>
<O T="CADDLine">

```

```

<P N="Color" V="#FF0000" T="Text" />
<P N="Thickness" V="2" />
<O T="Point" X="12" Y="0" />
<O T="Point" X="-12" Y="0" />
</O>
<O T="CADDDimensionLine" Y="0" X="0" RZ="0">
  <P N="Guard" V="stubL.NE.0" />
  <P N="Label" V="Left Stub = %d" T="Text" />
  <O T="Point" Y="BackWallHeight" X="-AbutLength/2" />
  <O T="Point" Y="BackWallHeight" X="-AbutLength/2+stubL" />
  <O T="Point" Y="BackWallHeight+margin*3" X="0" />
</O>
<O T="CADDDimensionLine" Y="0" X="0" RZ="0">
  <P N="Guard" V="stubR.NE.0" />
  <P N="Label" V="Right Stub = %d" T="Text" />
  <O T="Point" Y="BackWallHeight" X="AbutLength/2-stubR" />
  <O T="Point" Y="BackWallHeight" X="AbutLength/2" />
  <O T="Point" Y="BackWallHeight+margin*3" X="0" />
</O>
<O T="CADDDimensionLine" Y="0" X="0" RZ="0">
  <P N="Label" V="Abutment Length = %d" T="Text" />
  <O T="Point" Y="0" X="-AbutLength/2" />
  <O T="Point" Y="0" X="AbutLength/2" />
  <O T="Point" Y="-margin*4" X="0" />
</O>
<O T="CADDDimensionLine" Y="0" X="0" RZ="0">
  <P N="Label" V="%d" T="Text" />
  <O T="Point" Y="PedSlope*AbutLength/2" X="-AbutLength/2" />
  <O T="Point" Y="BackWallHeight" X="-AbutLength/2" />
  <O T="Point" Y="BackWallHeight/2" X="-AbutLength/2-margin*3" />
</O>
<O T="CADDDimensionLine" Y="0" X="0" RZ="0">
  <P N="Label" V="%d" T="Text" />
  <O T="Point" Y="-PedSlope*AbutLength/2" X="AbutLength/2" />
  <O T="Point" Y="BackWallHeight" X="AbutLength/2" />
  <O T="Point" Y="BackWallHeight/2" X="AbutLength/2+margin*3" />
</O>
</O>
<O N="Abutment Backwall - Section" T="CADD">
  <P N="margin" V="2" />
  <O T="CADDShape">
    <P N="Color" V="rgb(0, 0, 0)" T="Text" />
    <P N="Thickness" V="4" />
    <P N="IsClosed" V="T" T="Text" />
    <O T="Point" X="0" Y="0" />
    <O T="Point" X="BackWallThick" Y="0" />
    <O T="Point" X="BackWallThick" Y="BackWallHeight" />
    <O T="Point" X="BackWallNotchH" Y="BackWallHeight" />
    <O T="Point" X="BackWallNotchH" Y="BackWallHeight-BackWallNotchV" />
    <O T="Point" X="0" Y="BackWallHeight-BackWallNotchV" />
  </O>
  <O T="CADDLine">
    <P N="Color" V="#FF0000" T="Text" />
    <P N="Thickness" V="3" />
    <O T="Point" X="0" Y="-4" />
    <O T="Point" X="0" Y="4" />
  </O>
  <O T="CADDLine">
    <P N="Color" V="#FF0000" T="Text" />
    <P N="Thickness" V="3" />
    <O T="Point" X="4" Y="0" />
    <O T="Point" X="-4" Y="0" />
  </O>

```

```

</O>
<O T="CADDDimensionLine" Y="0" X="0" RZ="0">
  <P N="Label" V="Height = %d" T="Text" />
  <O T="Point" Y="0" X="BackWallThick" />
  <O T="Point" Y="BackWallHeight" X="BackWallThick" />
  <O T="Point" Y="BackWallHeight/2" X="BackWallThick+margin*3" />
</O>
<O T="CADDDimensionLine" Y="0" X="0" RZ="0">
  <P N="Label" V="Notch 'V' = %d" T="Text" />
  <O T="Point" Y="BackWallHeight-BackWallNotchV" X="BackWallNotchH" />
  <O T="Point" Y="BackWallHeight" X="BackWallNotchH" />
  <O T="Point" Y="0" X="BackWallNotchH-margin*6" />
</O>
<O T="CADDDimensionLine" Y="0" X="0" RZ="0">
  <P N="Label" V="Notch 'H' = %d" T="Text" />
  <O T="Point" Y="BackWallHeight" X="BackWallNotchH" />
  <O T="Point" Y="BackWallHeight" X="BackWallThick" />
  <O T="Point" Y="BackWallHeight+margin*2" X="0" />
</O>
<O T="CADDDimensionLine" Y="0" X="0" RZ="0">
  <P N="Label" V="Thickness = %d" T="Text" />
  <O T="Point" Y="0" X="0" />
  <O T="Point" Y="0" X="BackWallThick" />
  <O T="Point" Y="-margin*3" X="0" />
</O>
</O>
</O>

```

**Wingwall (BB)**

[Wing Wall (BB)] object can be placed on either side of an abutment with or without a sloped side and angled end. The top of the Wing Wall may also slope based upon the relative difference between the "Top Wall Height", "Crown Height", and "Lower Wall Height." The side of the wall which is straight or sloped can be controlled with the "Slope" parameter.

Limitations:

- 1) Does not include wingwall barrier
- 2) Does not include reinforcement
- 3) Does not include architectural details



**Wing Wall (BB)** BY BENJAMIN BLASLEN

WingWallData ▾

Refresh

<div style="border: 1px solid #ccc; padding: 2px;"> <small>Length</small> Total Wall Longitudinal Length, in.  <div style="text-align: center; font-weight: bold; margin-top: 5px;">299.5</div> </div>	<div style="border: 1px solid #ccc; padding: 2px;"> <small>DistanceToCrown</small> Distance from left side to Crown, in.  <div style="text-align: center; font-weight: bold; margin-top: 5px;">234</div> </div>	<div style="border: 1px solid #ccc; padding: 2px;"> <small>Base_Width</small> Wall Width at Base, in.  <div style="text-align: center; font-weight: bold; margin-top: 5px;">60</div> </div>
<div style="border: 1px solid #ccc; padding: 2px;"> <small>Top_Width</small> Ratio of Wall Width at Top to Height, x/y  <div style="text-align: center; font-weight: bold; margin-top: 5px;"><math>\frac{1}{12} = 0.0833</math></div> </div>	<div style="border: 1px solid #ccc; padding: 2px;"> <small>Top_Wall_Height</small> Height of wall at higher end, in.  <div style="text-align: center; font-weight: bold; margin-top: 5px;">215.4</div> </div>	<div style="border: 1px solid #ccc; padding: 2px;"> <small>Crown_Height</small> Height of wall at crown, in.  <div style="text-align: center; font-weight: bold; margin-top: 5px;">200.76</div> </div>
<div style="border: 1px solid #ccc; padding: 2px;"> <small>Lower_Wall_Height</small> Height of wall at lower end, in.  <div style="text-align: center; font-weight: bold; margin-top: 5px;">186.6</div> </div>	<div style="border: 1px solid #ccc; padding: 2px;"> <small>rSlope</small> Slope of rail on top of wall.  <div style="text-align: center; font-weight: bold; margin-top: 5px;">0.0988</div> </div>	<div style="border: 1px solid #ccc; padding: 2px;"> <small>Skew</small> Skew angle of end of wall, rad  <div style="text-align: center; font-weight: bold; margin-top: 5px;">0.3</div> </div>
<div style="border: 1px solid #ccc; padding: 2px;"> <small>Slope</small> Wall sloped to the '1' for Right, or '2' for Left  <div style="text-align: center; font-weight: bold; margin-top: 5px;">2</div> </div>		

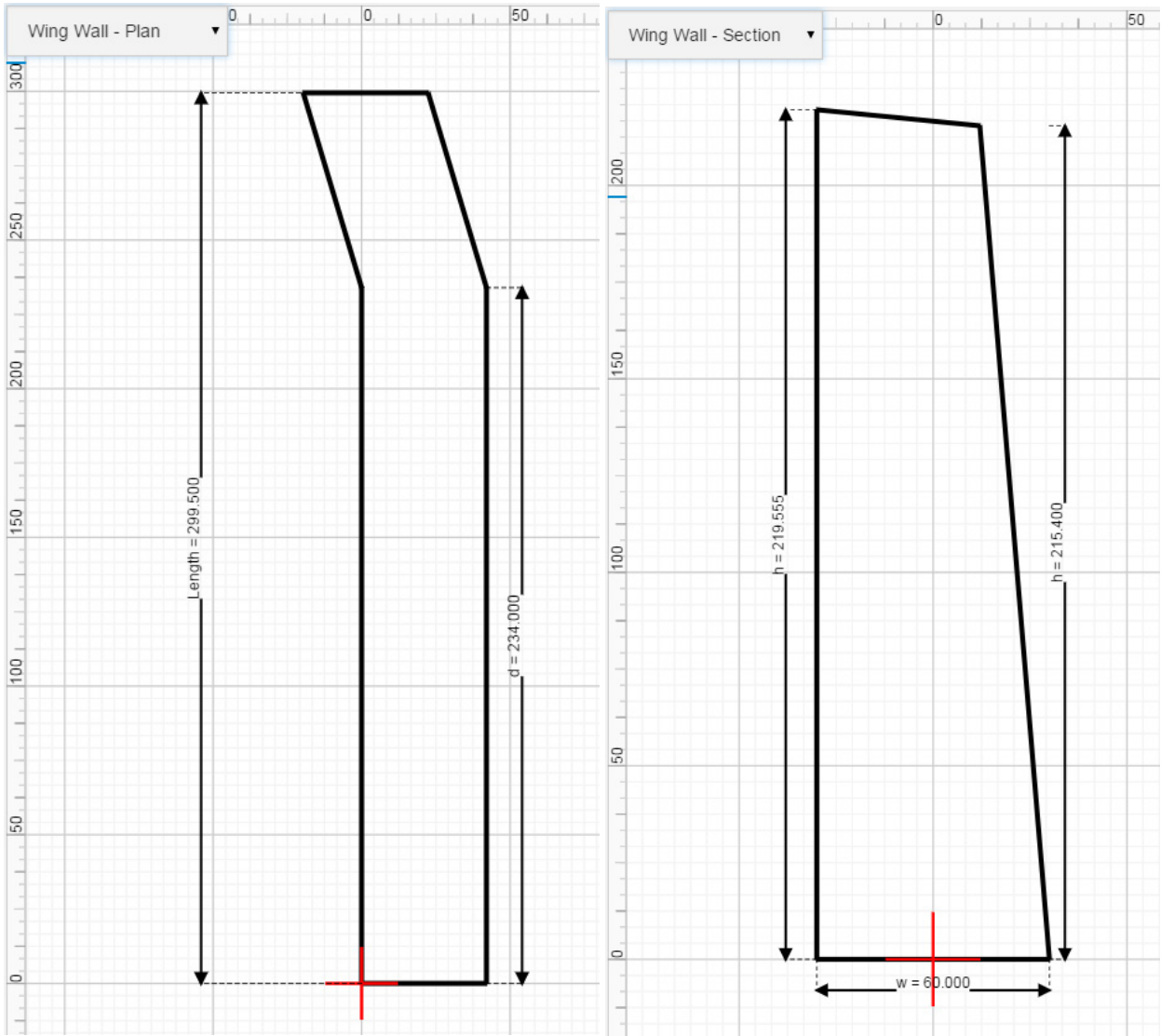

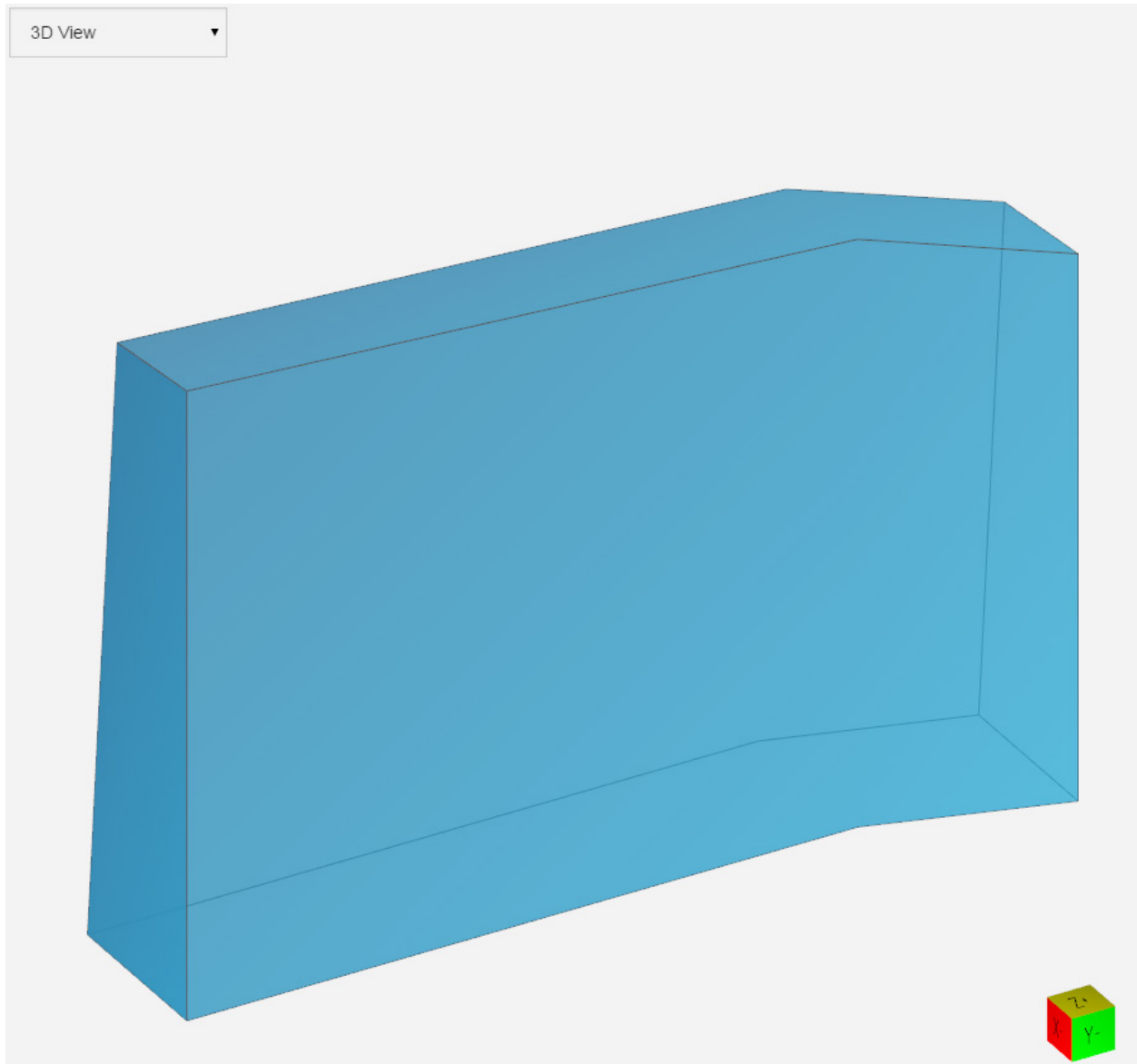

### ParamML Code

```

<O N="Wing Wall (BB)" T="Project">
  <P N="Color" V="#00B2EE" T="Text" />
  <P N="Opacity" V="0.8" />
  <O N="ObjDesc" T="Group">
    <!--
    <p> |Wing Wall (BB)| object can be placed on either side of an abutment with
    or without a sloped side and angled end. The top of the Wing Wall may also slope
    based upon the relative difference between the "Top Wall Height", "Crown Height",
    and "Lower Wall Height." The side of the wall which is straight or sloped can be controlled with
    the "Slope" parameter.
    </p>
    -->
    <!--<p>
    <i>Created <b>Benjamin Blasen</b> on 7/9/2015</i>
    </p-->
  </O>
</O>

```

```

    <!--<p>
Limitations:
<br>1) Does not include wingwall barrier</br>
<br>2) Does not include reinforcement</br>
<br>3) Does not include architectural details</br>
</p-->
</O>
<O N="WingWallData" T="Group">
  <P N="Length" V="299.5" D="Total Wall Longitudinal Length, in." Role="Input" Category="WingWallData" />
  <P N="DistanceToCrown" V="234" D="Distance from left side to Crown, in." Role="Input"
Category="WingWallData" />
  <P N="Base_Width" V="60" D="Wall Width at Base, in." Role="Input" Category="WingWallData" />
  <P N="Top_Width" V="1/12" D="Ratio of Wall Width at Top to Height, x/y" Role="Input"
Category="WingWallData" />
  <P N="Top_Wall_Height" V="215.4" D="Height of wall at higher end, in." Role="Input"
Category="WingWallData" />
  <P N="Crown_Height" V="200.76" D="Height of wall at crown, in." Role="Input" Category="WingWallData" />
  <P N="Lower_Wall_Height" V="186.6" D="Height of wall at lower end, in." Role="Input"
Category="WingWallData" />
  <P N="rSlope" V="0.0988" D="Slope of rail on top of wall." Role="Input" Category="WingWallData" />
  <P N="Skew" V="0.3" D="Skew angle of end of wall, rad" Role="Input" Category="WingWallData" />
  <P N="Slope" V="2" D="Wall sloped to the '1' for Right, or '2' for Left" Role="Input" Category="WingWallData"
/>
</O>
<O N="Sloped to the right" T="Volume">
  <P N="Guard" V="Slope.EQ.1" />
  <O T="Surface" D="1st Plane, Insertion Point at center of base width">
    <O T="Point" X="0" Z="0" Y="-Base_Width/2" />
    <O T="Point" X="0" Z="Top_Wall_Height" Y="Base_Width/2-(Base_Width-Top_Width*Top_Wall_Height)" />
    <O T="Point" X="0" Z="Top_Wall_Height+rSlope*(Base_Width-Top_Width*Top_Wall_Height)"
Y="Base_Width/2" />
    <O T="Point" X="0" Z="0" Y="Base_Width/2" />
  </O>
  <O T="Surface" D="2nd Plane, located at crown">
    <O T="Point" X="DistanceToCrown" Z="0" Y="-Base_Width/2" />
    <O T="Point" X="DistanceToCrown" Z="Crown_Height" Y="Base_Width/2-(Base_Width-
Top_Width*Crown_Height)" />
    <O T="Point" X="DistanceToCrown" Z="Crown_Height+rSlope*(Base_Width-Top_Width*Top_Wall_Height)"
Y="Base_Width/2" />
    <O T="Point" X="DistanceToCrown" Z="0" Y="Base_Width/2" />
  </O>
  <O T="Surface" D="3rd Plane, end of wall which may skew">
    <O T="Point" X="Length" Z="0" Y="-Base_Width/2+Skew*(Length-DistanceToCrown)" />
    <O T="Point" X="Length" Z="Lower_Wall_Height" Y="Base_Width/2-(Base_Width-
Top_Width*Lower_Wall_Height)+Skew*(Length-DistanceToCrown)" />
    <O T="Point" X="Length" Z="Lower_Wall_Height+rSlope*(Base_Width-Top_Width*Top_Wall_Height)"
Y="Base_Width/2+Skew*(Length-DistanceToCrown)" />
    <O T="Point" X="Length" Z="0" Y="Base_Width/2+Skew*(Length-DistanceToCrown)" />
  </O>
</O>
<O N="Sloped to the left" T="Volume" X="0" Y="0">
  <P N="Guard" V="Slope.EQ.2" />
  <O T="Surface" D="1st Plane, Insertion Point at center of base width">
    <O T="Point" X="0" Z="0" Y="-Base_Width/2" />
    <O T="Point" X="0" Z="Top_Wall_Height+rSlope*(Base_Width-Top_Width*Top_Wall_Height)" Y="-
Base_Width/2" />

```



```

    <O T="Point" X="0" Z="Top_Wall_Height" Y="Base_Width/2-(Top_Width*Top_Wall_Height)" />
    <O T="Point" X="0" Z="0" Y="Base_Width/2" />
  </O>
  <O T="Surface" D="2nd Plane, located at crown">
    <O T="Point" X="DistanceToCrown" Z="0" Y="-Base_Width/2" />
    <O T="Point" X="DistanceToCrown" Z="Crown_Height+rSlope*(Base_Width-Top_Width*Top_Wall_Height)"
Y="-Base_Width/2" />
    <O T="Point" X="DistanceToCrown" Z="Crown_Height" Y="Base_Width/2-(Top_Width*Crown_Height)" />
    <O T="Point" X="DistanceToCrown" Z="0" Y="Base_Width/2" />
  </O>
  <O T="Surface" D="3rd Plane, end of wall which may skew">
    <O T="Point" X="Length" Z="0" Y="-Base_Width/2+Skew*(Length-DistanceToCrown)*-1" />
    <O T="Point" X="Length" Z="Lower_Wall_Height+rSlope*(Base_Width-Top_Width*Top_Wall_Height)" Y="-
Base_Width/2+Skew*(Length-DistanceToCrown)*-1" />
    <O T="Point" X="Length" Z="Lower_Wall_Height" Y="Base_Width/2-
(Top_Width*Lower_Wall_Height)+Skew*(Length-DistanceToCrown)*-1" />
    <O T="Point" X="Length" Z="0" Y="Base_Width/2+Skew*(Length-DistanceToCrown)*-1" />
  </O>
</O>
<!--
  CADD Section for BrIM Object Standard documentation
-->
<O N="Wing Wall - Section" T="CADD">
  <P N="margin" V="2" />
  <O T="CADDShape" Y="0" X="0" RZ="-PI/2">
    <P N="Color" V="rgb(0, 0, 0)" T="Text" />
    <P N="Thickness" V="4" />
    <P N="IsClosed" V="T" T="Text" />
    <O T="Point" X="0" Y="-Base_Width/2" />
    <O T="Point" X="Top_Wall_Height" Y="Base_Width/2-(Base_Width-Top_Width*Top_Wall_Height)" />
    <O T="Point" X="Top_Wall_Height+rSlope*(Base_Width-Top_Width*Top_Wall_Height)" Y="Base_Width/2"
/>
    <O T="Point" X="0" Y="Base_Width/2" />
  </O>
  <O T="CADDLine">
    <P N="Color" V="#FF0000" T="Text" />
    <P N="Thickness" V="2" />
    <O T="Point" X="0" Y="-12" />
    <O T="Point" X="0" Y="12" />
  </O>
  <O T="CADDLine">
    <P N="Color" V="#FF0000" T="Text" />
    <P N="Thickness" V="2" />
    <O T="Point" X="12" Y="0" />
    <O T="Point" X="-12" Y="0" />
  </O>
  <O T="CADDDimensionLine" Y="0" X="0" RZ="0">
    <P N="Label" V="w = %d" T="Text" />
    <O T="Point" Y="0" X="-Base_Width/2" />
    <O T="Point" Y="0" X="Base_Width/2" />
    <O T="Point" Y="-margin*4" X="0" />
  </O>
  <O T="CADDDimensionLine" Y="0" X="0" RZ="0">
    <P N="Label" V="h = %d" T="Text" />
    <O T="Point" Y="0" X="-Base_Width/2" />

```

```

    <O T="Point" Y="Top_Wall_Height+rSlope*(Base_Width-Top_Width*Top_Wall_Height)" X="-Base_Width/2"
/>
  <O T="Point" Y="0" X="-Base_Width/2-margin*4" />
</O>
<O T="CADDDimensionLine" Y="0" X="0" RZ="0">
  <P N="Label" V="h = %d" T="Text" />
  <O T="Point" Y="0" X="Base_Width/2" />
  <O T="Point" Y="Top_Wall_Height" X="Base_Width/2" />
  <O T="Point" Y="0" X="Base_Width/2+margin*2" />
</O>
</O>
<O N="Wing Wall - Plan" T="CADD">
  <P N="margin" V="2" />
  <P N="top" V="(Base_Width-Top_Width*Top_Wall_Height)" />
  <O T="CADDShape" Y="0" X="0" RZ="0">
    <P N="Color" V="rgb(0, 0, 0)" T="Text" />
    <P N="Thickness" V="4" />
    <P N="IsClosed" V="T" T="Text" />
    <O T="Point" Y="0" X="0" />
    <O T="Point" Y="DistanceToCrown" X="0" />
    <O T="Point" Y="Length" X="-(Length-DistanceToCrown)*Skew" />
    <O T="Point" Y="Length" X="-(Length-DistanceToCrown)*Skew+top" />
    <O T="Point" Y="DistanceToCrown" X="top" />
    <O T="Point" Y="0" X="top" />
  </O>
  <O T="CADDLine">
    <P N="Color" V="#FF0000" T="Text" />
    <P N="Thickness" V="2" />
    <O T="Point" X="0" Y="-12" />
    <O T="Point" X="0" Y="12" />
  </O>
  <O T="CADDLine">
    <P N="Color" V="#FF0000" T="Text" />
    <P N="Thickness" V="2" />
    <O T="Point" X="12" Y="0" />
    <O T="Point" X="-12" Y="0" />
  </O>
  <O T="CADDDimensionLine" Y="0" X="0" RZ="0">
    <P N="Label" V="d = %d" T="Text" />
    <O T="Point" Y="0" X="top" />
    <O T="Point" Y="DistanceToCrown" X="top" />
    <O T="Point" Y="DistanceToCrown/2" X="top+6*margin" />
  </O>
  <O T="CADDDimensionLine" Y="0" X="0" RZ="0">
    <P N="Label" V="Length = %d" T="Text" />
    <O T="Point" Y="0" X="0" />
    <O T="Point" Y="Length" X="0" />
    <O T="Point" Y="DistanceToCrown/2" X="-top-6*margin" />
  </O>
</O>
</O>
</O>

```

## Cheekwall

[Cheekwall] library object is meant to be placed on top of [Stem Abutment (BB)] library object. This object is placed outside of the girders on the edge of the abutment as a visual cover and protection of the bearing connection. The top of the cheekwall has the option to slope using the "TopSlope" parameter. The bottom of the cheekwall has the option to follow a stem pedestal slope using the "PedSlope" parameter.

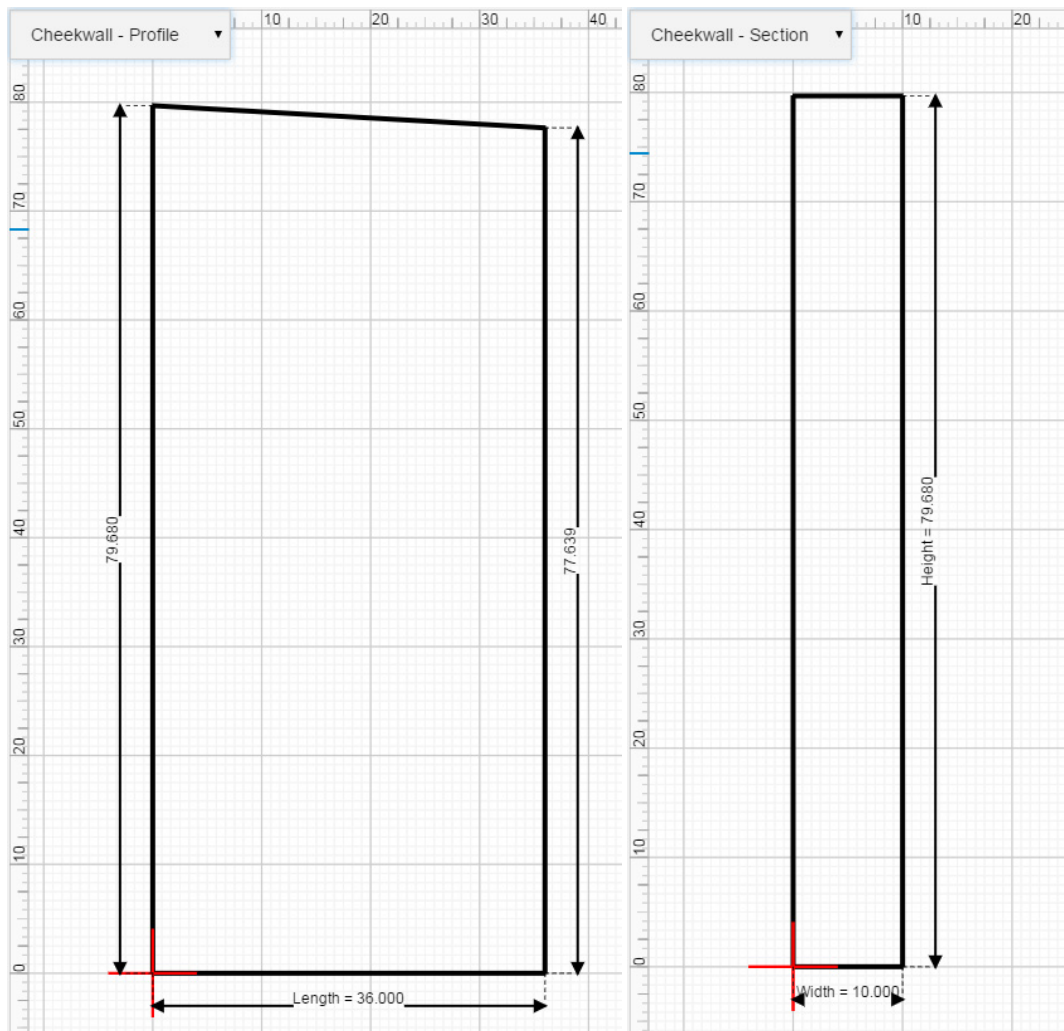

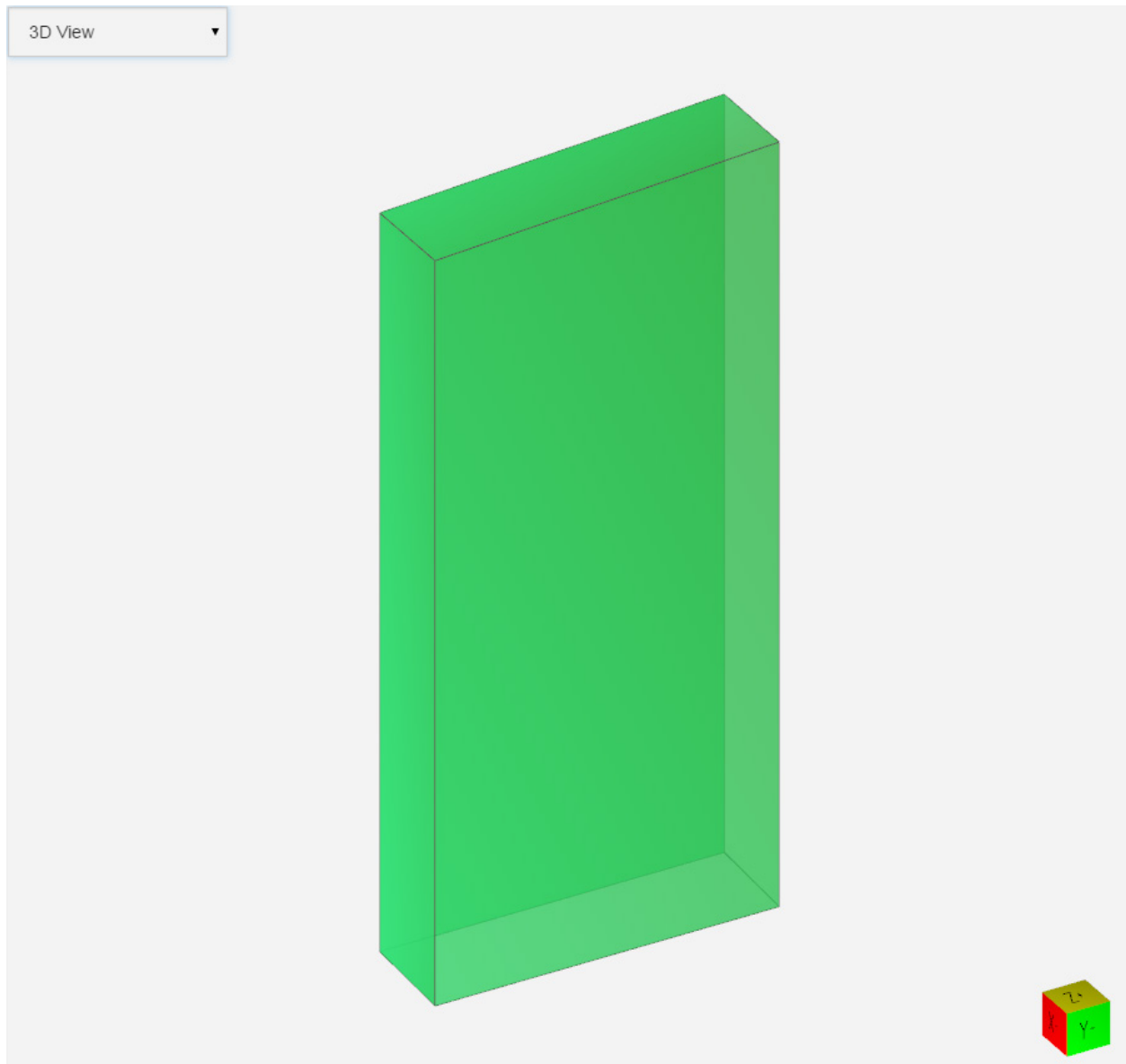

### ParamML Code

```

<O N="Cheekwall" T="Project">
  <P N="Color" V="#00FF66" T="Text" />
  <P N="Opacity" V="0.8" />
  <O N="ObjDesc" T="Group">
    <!--<p> |Cheekwall| library object is meant to be placed on top of
    |Stem Abutment (BB)| library object. This object is placed outside of the girders
    on the edge of the abutment as a visual cover and protection of the bearing connection.</p>
    <p>
    The top of the cheekwall has the option to slope using the "TopSlope" parameter. The bottom of
    the cheekwall has the option to follow a stem pedestal slope using the "PedSlope" parameter.
    </p-->
    <!-- <i>created by <b>Benjamin Blasen</b> on 7/17/2015</i> -->
    <!--
  -->

```

```

</O>
<O T="Group">
  <P N="Height" V="79.68" D="Cheekwall height at front face, in." Role="Input" UT="Length" UC="Properties" />
  <P N="Width" V="10" D="Abutment Width, in." Role="Input" UT="Length" UC="Properties" />
  <P N="Length" V="36" D="Abutment Width, in." Role="Input" UT="Length" UC="Properties" />
  <P N="PedSlope" V="0.069" D="Slope of surface for pedestal mounts" Role="Input" UT="Length"
UC="Properties" />
  <P N="TopSlope" V="-0.0567" D="Slope of top of cheekwall" Role="Input" UT="Length" UC="Properties" />
</O>
<O T="Volume">
  <O T="Surface" X="Length">
    <O T="Point" Y="Width/2" Z="Width/2*PedSlope" />
    <O T="Point" Y="Width/2" Z="Height" />
    <O T="Point" Y="-Width/2" Z="Height" />
    <O T="Point" Y="-Width/2" Z="-Width/2*PedSlope" />
  </O>
  <O T="Surface" X="0">
    <O T="Point" Y="Width/2" Z="Width/2*PedSlope" />
    <O T="Point" Y="Width/2" Z="Height+Length*TopSlope" />
    <O T="Point" Y="-Width/2" Z="Height+Length*TopSlope" />
    <O T="Point" Y="-Width/2" Z="-Width/2*PedSlope" />
  </O>
</O>
<O N="Cheekwall - Section" T="CADD">
  <P N="margin" V="3" />
  <O T="CADDShape">
    <P N="Color" V="rgb(0, 0, 0)" T="Text" />
    <P N="Thickness" V="4" />
    <P N="IsClosed" V="T" T="Text" />
    <O T="Point" X="0" Y="0" />
    <O T="Point" X="Width" Y="0" />
    <O T="Point" X="Width" Y="Height" />
    <O T="Point" X="0" Y="Height" />
  </O>
  <O T="CADDLine">
    <P N="Color" V="#FF0000" T="Text" />
    <P N="Thickness" V="2" />
    <O T="Point" X="0" Y="-4" />
    <O T="Point" X="0" Y="4" />
  </O>
  <O T="CADDLine">
    <P N="Color" V="#FF0000" T="Text" />
    <P N="Thickness" V="2" />
    <O T="Point" X="4" Y="0" />
    <O T="Point" X="-4" Y="0" />
  </O>
  <O T="CADDDimensionLine" Y="0" X="0" RZ="0">
    <P N="Label" V="Width = %d" T="Text" />
    <O T="Point" Y="0" X="0" />
    <O T="Point" Y="0" X="Width" />
    <O T="Point" Y="-margin" X="0" />
  </O>
  <O T="CADDDimensionLine" Y="0" X="0" RZ="0">
    <P N="Label" V="Height = %d" T="Text" />
    <O T="Point" Y="0" X="Width" />
    <O T="Point" Y="Height" X="Width" />
  </O>

```

```

    <O T="Point" Y="0" X="Width+margin" />
  </O>
</O>
<O N="Cheekwall - Profile" T="CADD">
  <P N="margin" V="3" />
  <O T="CADDShape">
    <P N="Color" V="rgb(0, 0, 0)" T="Text" />
    <P N="Thickness" V="4" />
    <P N="IsClosed" V="T" T="Text" />
    <O T="Point" X="0" Y="0" />
    <O T="Point" X="Length" Y="0" />
    <O T="Point" X="Length" Y="Height+Length*TopSlope" />
    <O T="Point" X="0" Y="Height" />
  </O>
  <O T="CADDLine">
    <P N="Color" V="#FF0000" T="Text" />
    <P N="Thickness" V="2" />
    <O T="Point" X="0" Y="-4" />
    <O T="Point" X="0" Y="4" />
  </O>
  <O T="CADDLine">
    <P N="Color" V="#FF0000" T="Text" />
    <P N="Thickness" V="2" />
    <O T="Point" X="4" Y="0" />
    <O T="Point" X="-4" Y="0" />
  </O>
  <O T="CADDDimensionLine" Y="0" X="0" RZ="0">
    <P N="Label" V="Length = %d" T="Text" />
    <O T="Point" Y="0" X="0" />
    <O T="Point" Y="0" X="Length" />
    <O T="Point" Y="-margin" X="0" />
  </O>
  <O T="CADDDimensionLine" Y="0" X="0" RZ="0">
    <P N="Label" V="%d" T="Text" />
    <O T="Point" Y="0" X="Length" />
    <O T="Point" Y="Height+Length*TopSlope" X="Length" />
    <O T="Point" Y="0" X="Length+margin" />
  </O>
  <O T="CADDDimensionLine" Y="0" X="0" RZ="0">
    <P N="Label" V="%d" T="Text" />
    <O T="Point" Y="0" X="0" />
    <O T="Point" Y="Height" X="0" />
    <O T="Point" Y="0" X="-margin" />
  </O>
</O>
</O>
</O>

```

**ConcPedestal (BB)**

|ConcPedestal (BB)| library object is for providing level bearing seats on top of |Stem Abutment (BB)| or |Hammerhead Pier Cap (BB)| library objects. If the support seat is sloped, the thickness of the pedestal is variable. The top and bottom widths can also vary.

open Brim		ConcPedestal (BB) <small>BY BULHANN BLASIN</small>	
 Refresh			PedestalData ▾
SupportSlope Slope of support.	SupportTopWidth Top width.	SupportBotWidth Bottom width.	
0.069	36	46	
SupportL Support longitudinal length.	SupportDepth Depth of pedestal.		
36	4		

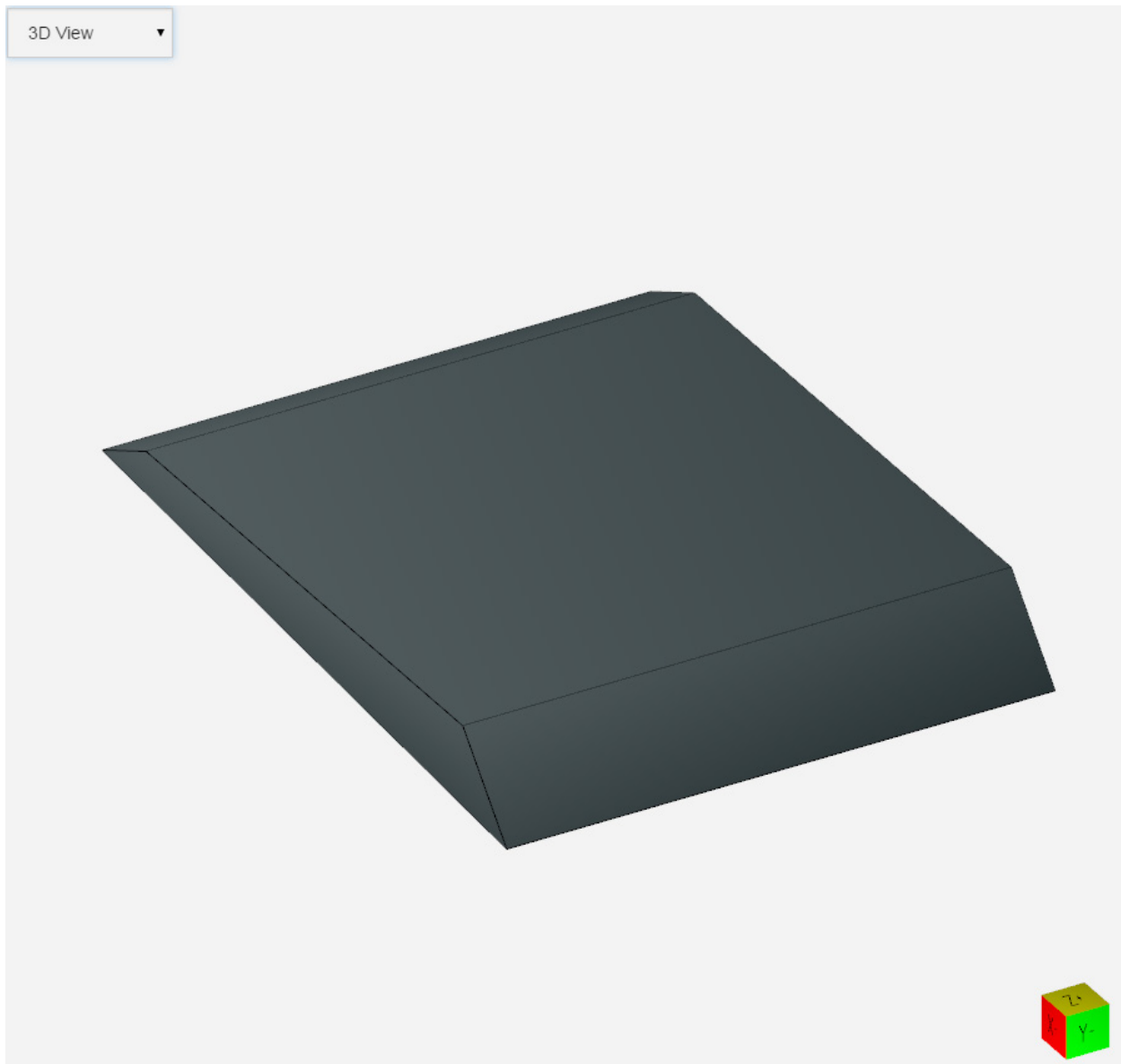

ParamML Code

```

<O N="ConcPedestal (BB)" T="Project">
  <O N="ObjDesc" T="Group">
    <!--<p> |ConcPedestal (BB)| library object is meant to be placed on top of
    abutments or piers.</p>-->
    <!-- <i>Created by <b>Alex Harrison</b> on 6/3/2015</i>-->
    <!-- <i>Updated by <b>Benjamin Blasen</b> on 7/27/2015</i>-->
    <!--
  -->
</O>
<O N="PedestalData" T="Group">
  <P N="PedestalOffset" V="0" D="Location of edge of pedestal, in." Role="Input" Category="PedestalData"
  UT="Length" UC="Properties" />
  <P N="SupportSlope" V=".069" D="Slope of support." Role="Input" Category="PedestalData" />
  <P N="SupportTopWidth" V="36" D="Top width." Role="Input" Category="PedestalData" />
  <P N="SupportBotWidth" V="46" D="Bottom width." Role="Input" Category="PedestalData" />
  <P N="SupportL" V="36" D="Support longitudinal length." Role="Input" Category="PedestalData" />
  <P N="SupportDepth" V="4" D="Depth of pedestal." Role="Input" Category="PedestalData" />
</O>
<O N="Pedestal" T="Volume">
  <P N="xStart" V="PedestalOffset-SupportL/2" />
  <P N="xEnd" V="PedestalOffset+SupportL/2" />
  <O T="Section">
    <O T="Point" X="xStart" Y="SupportBotWidth/2" Z="SupportBotWidth/2*SupportSlope" />
    <O T="Point" X="xEnd" Y="SupportBotWidth/2" Z="SupportBotWidth/2*SupportSlope" />
    <O T="Point" X="xEnd" Y="-SupportBotWidth/2" Z="-SupportBotWidth/2*SupportSlope" />
    <O T="Point" X="xStart" Y="-SupportBotWidth/2" Z="-SupportBotWidth/2*SupportSlope" />
  </O>
  <O T="Section" Z="SupportDepth">
    <O T="Point" X="xStart" Y="SupportTopWidth/2" />
    <O T="Point" X="xEnd" Y="SupportTopWidth/2" />
    <O T="Point" X="xEnd" Y="-SupportTopWidth/2" />
    <O T="Point" X="xStart" Y="-SupportTopWidth/2" />
  </O>
</O>
<O T="Private">
  <O N="Reference" T="InsertionPoint">
    <P N="Size" V="1" />
  </O>
</O>
<O N="Elev from 3D" T="CADDFrom3D" RX="PI/2" RZ="PI/2">
  <P N="Obj3D" V="Pedestal" T="Group" />
</O>
</O>

```



## Drilled Shaft

|DrilledShaft| library object is used for a Drilled Shaft with parameters D, for Diameter and L, for Length. The reference insertion point is the center of the shaft at the top surface.

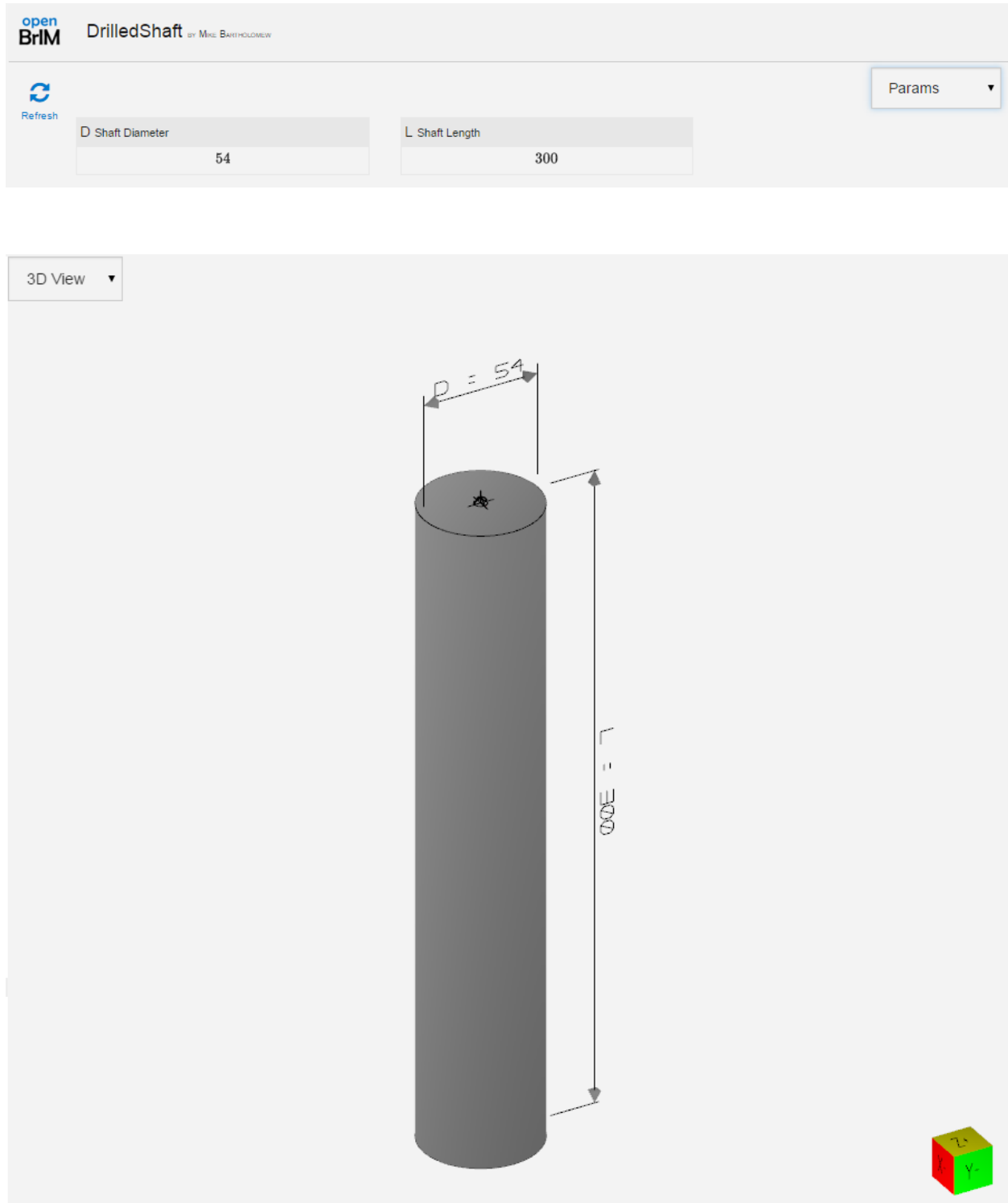

ParamML Code

```

<O N="DrilledShaft" T="Project"> <P N="D" V="54" D="Shaft Diameter" Role="Input" />

  <P N="L" V="300" D="Shaft Length" Role="Input" />
  <P N="Color" V="#D3D3D3" T="Text" />
  <!-- created by Mike Bartholomew on 12/21/2015 -->
  <O N="ObjDesc" T="Group">
    <!--<p> |DrilledShaft| library object is used for a Drilled Shaft with
      parameters D, for Diameter and L, for Length. The reference insertion point
      is the center of the shaft at the top.</p-->
  </O>
  <O N="ShaftSection" T="Section">
    <O T="Circle">
      <P N="Radius" V="D/2" />
    </O>
  </O>
  <O T="Volume">
    <P N="Section" V="ShaftSection" T="Section" />
    <O T="Point" Y="0" Z="0" X="0" />
    <O T="Point" Y="0" Z="-L" X="0" />
  </O>
  <O N="Dimension Lines" T="Group" AlignH="Warp" AlignT="None" AlignV="Warp">
    <P N="DimLineFontSize" V="L / 50" />
    <P N="DimLineArrowSize" V="L / 50" />
    <P N="DimLineMargin" V="L / 50" />
    <O T="DimensionLine" FontSize="DimLineFontSize" ArrowSize="DimLineArrowSize">
      <P N="Label" V="L = |d|" T="Text" />
      <O T="Point" Y="0" X="D/2 + DimLineMargin" Z="0" />
      <O T="Point" Y="0" X="D/2 + DimLineMargin" Z="-L" />
      <O T="Point" Y="0" X="D" Z="0" />
    </O>
    <O T="DimensionLine" FontSize="DimLineFontSize" ArrowSize="DimLineArrowSize">
      <P N="Label" V="D = |d|" T="Text" />
      <O T="Point" Y="0" X="-D/2" Z="DimLineMargin" />
      <O T="Point" Y="0" X="D/2" Z="DimLineMargin" />
      <O T="Point" Y="0" X="0" Z="D" />
    </O>
  </O>
  <O T="Private">
    <O N="Reference" T="InsertionPoint">
      <P N="Size" V="DimLineMargin" />
    </O>
  </O>
</O>

```

**Rectangular Footing**

open  
BrIM

Rectangular Footing BY MIKE BARTHOLMEW

Refresh

Params

Length Footing Length (Along Bridge Alignment)	Width Footing Width (Transverse to Bridge Alignment)	Depth Footing Depth
120	192	48
BotElev Footing Bottom Elevation		
0		

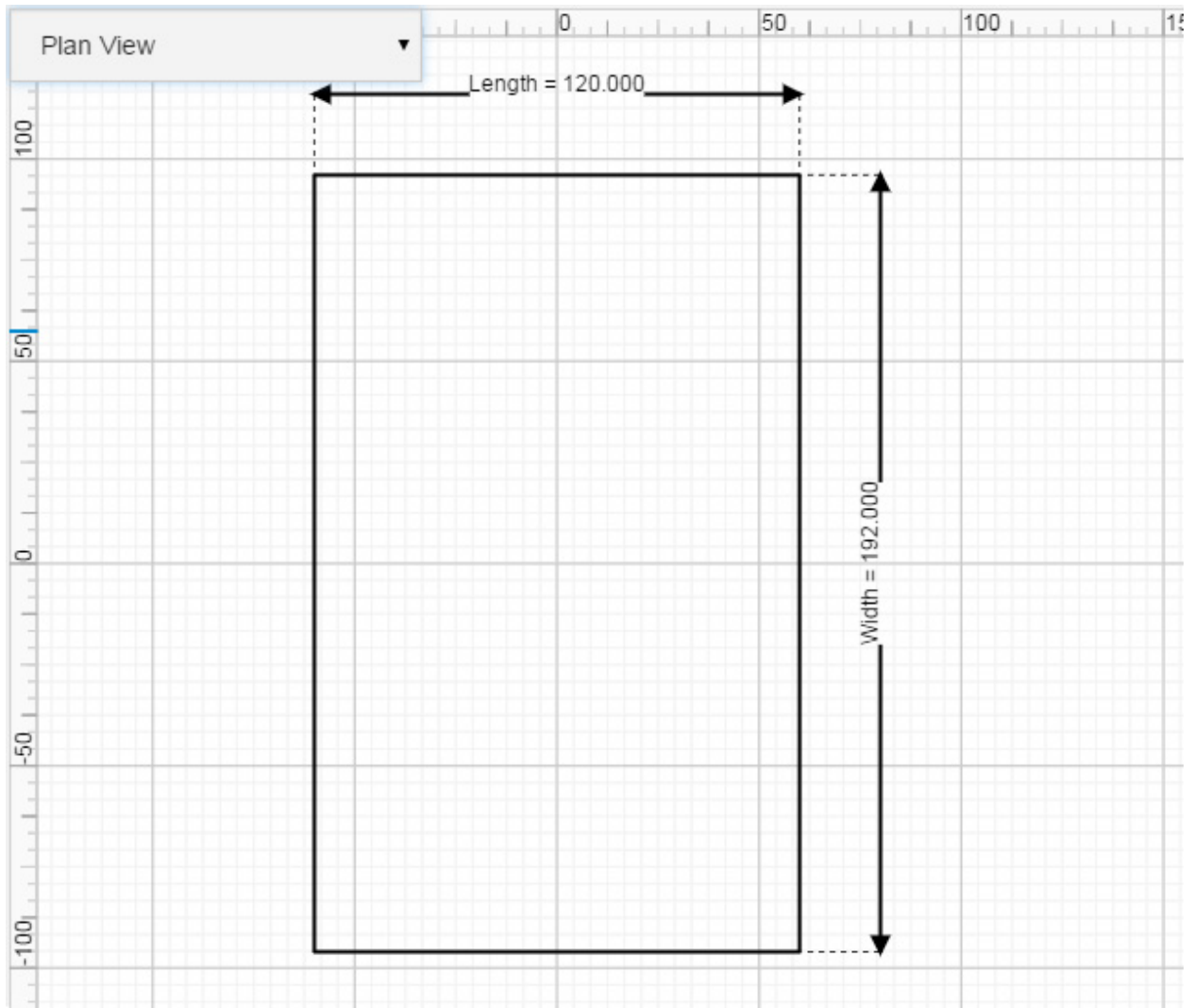

ParamML Code

```

<O N="Rectangular Footing" T="Project">
  <P N="Length" V="120" D="Footing Length (Along Bridge Alignment)" Role="Input" />
  <P N="Width" V="192" D="Footing Width (Transverse to Bridge Alignment)" Role="Input" />
  <P N="Depth" V="48" D="Footing Depth" Role="Input" />
  <P N="BotElev" V="0" D="Footing Bottom Elevation" Role="Input" />
  <P N="Opacity" V="0.8" />
  <!-- created by Mike Bartholomew on 6/2/2015 -->
  <O T="Surface" Z="BotElev">
    <P N="Thickness" V="Depth" />
    <O T="Point" X="-Length/2" Y="-Width/2" />
    <O T="Point" X="Length/2" Y="-Width/2" />
    <O T="Point" X="Length/2" Y="Width/2" />
    <O T="Point" X="-Length/2" Y="Width/2" />
  </O>
  <O N="Plan View" T="CADD">
    <P N="margin" V="2" />
    <O T="CADDShape" Y="0" X="0" RZ="0">
      <P N="Color" V="rgb(0, 0, 0)" T="Text" />
      <P N="Thickness" V="2" />
      <P N="IsClosed" V="T" T="Text" />
      <O T="Point" X="-Length/2" Y="-Width/2" />
      <O T="Point" X="Length/2" Y="-Width/2" />
      <O T="Point" X="Length/2" Y="Width/2" />
      <O T="Point" X="-Length/2" Y="Width/2" />
    </O>
    <O T="CADDDimensionLine" Y="0" X="0" RZ="0">
      <P N="Label" V="Width = %d" T="Text" />
      <O T="Point" X="Length/2+margin" Y="-Width/2" />
      <O T="Point" X="Length/2+margin" Y="Width/2" />
      <O T="Point" X="Length/2+10*margin" Y="Width/2" />
    </O>
    <O T="CADDDimensionLine" Y="0" X="0" RZ="0">
      <P N="Label" V="Length = %d" T="Text" />
      <O T="Point" X="-Length/2" Y="Width/2+margin" />
      <O T="Point" X="Length/2" Y="Width/2+margin" />
      <O T="Point" X="0" Y="Width/2+10*margin" />
    </O>
  </O>
  <O N="Longitudinal Elevation View" T="CADD">
    <P N="margin" V="2" />
    <O T="CADDShape" Y="0" X="0" RZ="0">
      <P N="Color" V="rgb(0, 0, 0)" T="Text" />
      <P N="Thickness" V="2" />
      <P N="IsClosed" V="T" T="Text" />
      <O T="Point" X="-Length/2" Y="BotElev" />
      <O T="Point" X="Length/2" Y="BotElev" />
      <O T="Point" X="Length/2" Y="Depth" />
      <O T="Point" X="-Length/2" Y="Depth" />
    </O>
    <O T="CADDDimensionLine" Y="0" X="0" RZ="0">
      <P N="Label" V="Length = %d" T="Text" />
      <O T="Point" X="-Length/2" Y="Depth+margin" />
      <O T="Point" X="Length/2" Y="Depth+margin" />
      <O T="Point" X="Length/2" Y="Depth+10*margin" />
    </O>
  </O>

```

```
</O>  
<O T="CADDDimensionLine" Y="0" X="0" RZ="0">  
  <P N="Label" V="Depth = %d" T="Text" />  
  <O T="Point" X="Length/2+margin" Y="BotElev" />  
  <O T="Point" X="Length/2+margin" Y="BotElev+Depth" />  
  <O T="Point" X="Length/2+10*margin" Y="0" />  
</O>  
</O>  
</O>
```

## Rectangular Column

**open**  
**BRIM** Rectangular Column BY MIKE BARTHOLOMEW

 Refresh

**Params** ▼

Depth Column Depth (Along Bridge Alignment)	Width Column Width (Transverse to Bridge Alignment)	TopElev Column Top Elevation
80	90	800
BotElev Column Bottom Elevation		
0		

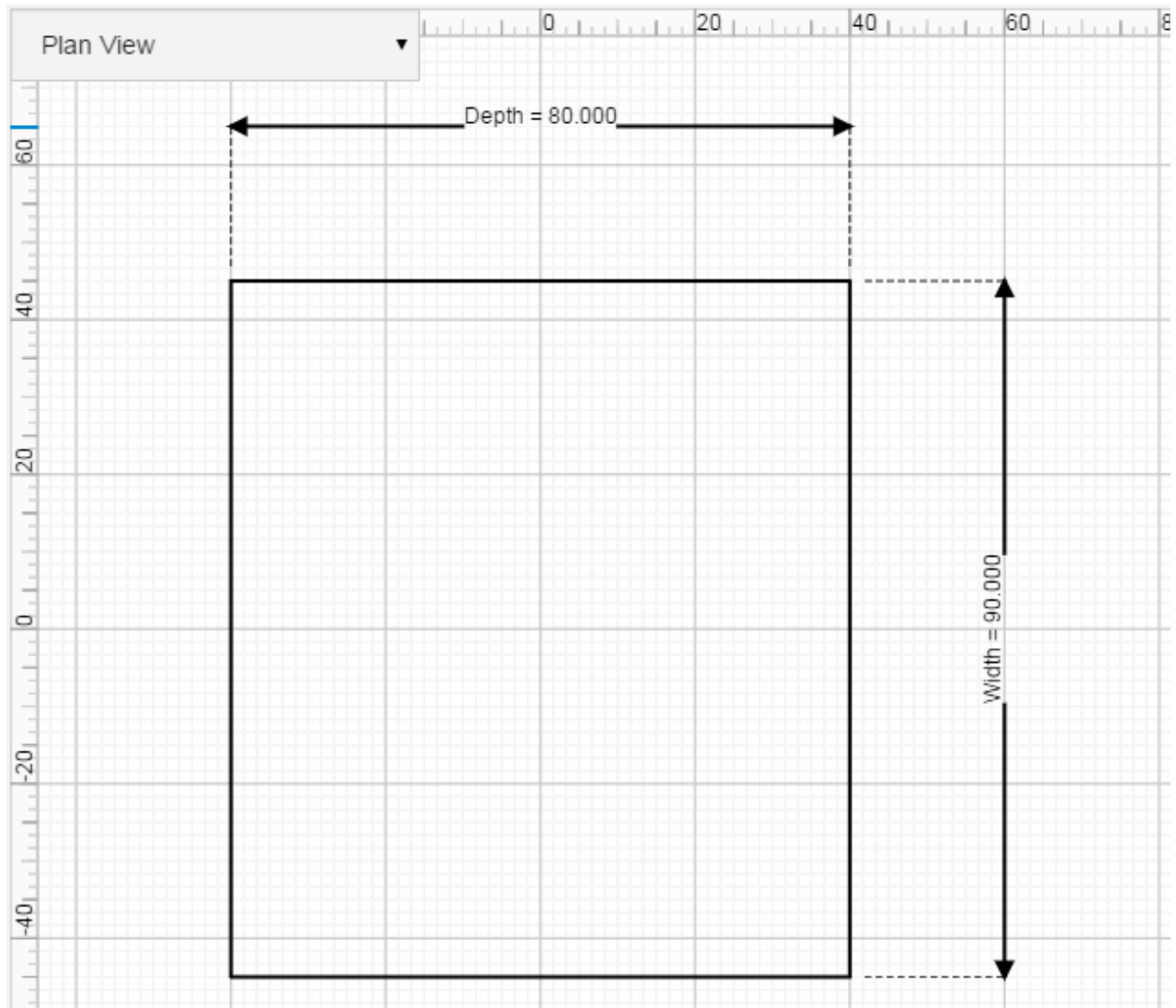

ParamML Code

```

<O N="Rectangular Column" T="Project">
  <P N="Depth" V="80" D="Column Depth (Along Bridge Alignment)" Role="Input" />
  <P N="Width" V="90" D="Column Width (Transverse to Bridge Alignment)" Role="Input" />
  <P N="TopElev" V="800" D="Column Top Elevation" Role="Input" />
  <P N="BotElev" V="0" D="Column Bottom Elevation" Role="Input" />
  <P N="Height" V="TopElev-BotElev" D="Column Height" />
  <!-- created by Mike Bartholomew on 6/2/2015 -->
  <O T="Surface">
    <P N="Opacity" V="0.8" />
    <P N="Thickness" V="Height" />
    <O T="Point" X="-Depth/2" Y="-Width/2" Z="BotElev" />
    <O T="Point" X="Depth/2" Y="-Width/2" Z="BotElev" />
    <O T="Point" X="Depth/2" Y="Width/2" Z="BotElev" />
    <O T="Point" X="-Depth/2" Y="Width/2" Z="BotElev" />
  </O>
  <O N="Plan View" T="CADD">
    <P N="margin" V="2" />
    <O T="CADDShape" Y="0" X="0" RZ="0">
      <P N="Color" V="rgb(0, 0, 0)" T="Text" />
      <P N="Thickness" V="2" />
      <P N="IsClosed" V="T" T="Text" />
      <O T="Point" X="-Depth/2" Y="-Width/2" />
      <O T="Point" X="Depth/2" Y="-Width/2" />
      <O T="Point" X="Depth/2" Y="Width/2" />
      <O T="Point" X="-Depth/2" Y="Width/2" />
    </O>
    <O T="CADDDimensionLine" Y="0" X="0" RZ="0">
      <P N="Label" V="Width = %d" T="Text" />
      <O T="Point" X="Depth/2+margin" Y="-Width/2" />
      <O T="Point" X="Depth/2+margin" Y="Width/2" />
      <O T="Point" X="Depth/2+10*margin" Y="Width/2" />
    </O>
    <O T="CADDDimensionLine" Y="0" X="0" RZ="0">
      <P N="Label" V="Depth = %d" T="Text" />
      <O T="Point" X="-Depth/2" Y="Width/2+margin" />
      <O T="Point" X="Depth/2" Y="Width/2+margin" />
      <O T="Point" X="0" Y="Width/2+10*margin" />
    </O>
  </O>
  <O N="Longitudinal Elevation View" T="CADD">
    <P N="margin" V="2" />
    <O T="CADDShape" Y="0" X="0" RZ="0">
      <P N="Color" V="rgb(0, 0, 0)" T="Text" />
      <P N="Thickness" V="2" />
      <P N="IsClosed" V="T" T="Text" />
      <O T="Point" X="-Depth/2" Y="BotElev" />
      <O T="Point" X="Depth/2" Y="BotElev" />
      <O T="Point" X="Depth/2" Y="BotElev+Height" />
      <O T="Point" X="-Depth/2" Y="BotElev+Height" />
    </O>
    <O T="CADDDimensionLine" Y="0" X="0" RZ="0">
      <P N="Label" V="Depth = %d" T="Text" />
      <O T="Point" X="-Depth/2" Y="BotElev+Height+2*margin" />
      <O T="Point" X="Depth/2" Y="BotElev+Height+2*margin" />
    </O>
  </O>

```

```
<O T="Point" X="Depth/2" Y="BotElev+Height+20*margin" />
</O>
<O T="CADDDimensionLine" Y="0" X="0" RZ="0">
  <P N="Label" V="Height = %d" T="Text" />
  <O T="Point" X="Depth/2+margin" Y="BotElev" />
  <O T="Point" X="Depth/2+margin" Y="BotElev+Height" />
  <O T="Point" X="Depth/2+40*margin" Y="0" />
</O>
</O>
</O>
```



### Hammerhead Pier Cap (BB)

The |Hammerhead Pier Cap (BB)| object is used as the superstructure support base for a rectangular single column pier. It serves as an extension of the pier column. The cap can have a constant cross slope or a crown section, and can have either a single or double row of |ConcPedestal (BB)| objects for bearing supports.

open BrIM Hammerhead Pier Cap (BB) BY BENJAMIN BLASEN

Refresh Pier Data ▾

PierLength Total Pier Length	PierWidth Pier Width	DistanceToCrown Distance from Left edge to Crown
436	60	1
PCrossSlopeL Cross Slope to left of Crown	PCrossSlopeR Cross Slope to Right of Crown	MinD_R Left Min Depth
-0.1	-0.1	52
MaxD_R Left Max Depth	ColumnExt Upper part of column	ColumnRadius Radius from Pier Cap to Colum
123	50	59.7
ExtensionL Left Sloped Section	ExtensionR Right Sloped Section	MinD_L Right Min Depth
158	158	52
MaxD_L Right Max Depth		
123		

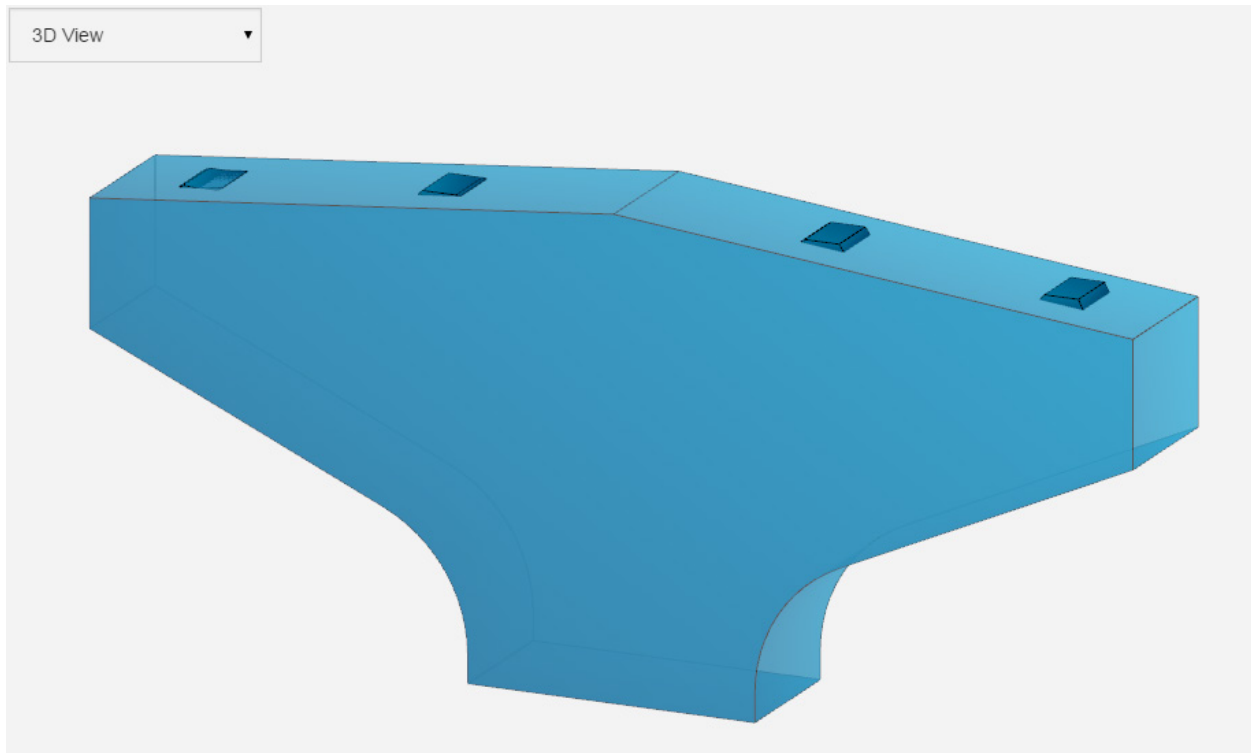

ParamML Code

```
<O N="Hammerhead Pier Cap (BB)" T="Project">
  <P N="Color" V="#00B2EE" T="Text" />
  <P N="Opacity" V="0.8" />
  <O N="ObjDesc" T="Group">
    <!--<p> | Hammerhead Pier Cap (BB) | library object.</p>-->
    <!-- <i>created by Alex Harrison on 6/3/2015 -->
    <!-- edited by Mike Bartholomew on 6/15/2015 -->
    <!-- edited by Benjamin Blasen on 7/24/2015</i> -->
    <!--<br>
```

## Limitations

- 1) 1 Crown/2 Slopes
- 2) Oriented Along a layout line
- 3) Ends of cap are normal to cap lay out line</br>

--&gt;

```
</O>
<O N="PierData" T="Group">
  <P N="PierLength" V="436" D="Total Pier Length" Role="Input" Category="Pier Data" />
  <P N="PierWidth" V="60" D="Pier Width" Role="Input" Category="Pier Data" />
  <P N="DistanceToCrown" V="1" D="Distance from Left edge to Crown" Role="Input" Category="Pier Data" />
  <P N="PCrossSlopeL" V="-0.1" D="Cross Slope to left of Crown" Role="Input" Category="Pier Data" />
  <P N="PCrossSlopeR" V="-0.1" D="Cross Slope to Right of Crown" Role="Input" Category="Pier Data" />
  <P N="MinD_R" V="52" D="Left Min Depth" Role="Input" Category="Pier Data" />
  <P N="MaxD_R" V="123" D="Left Max Depth" Role="Input" Category="Pier Data" />
  <P N="ColumnExt" V="50" D="Upper part of column" Role="Input" Category="Pier Data" />
  <P N="ColumnRadius" V="59.7" D="Radius from Pier Cap to Colum" Role="Input" Category="Pier Data" />
  <P N="ExtensionL" V="158" D="Left Sloped Section" Role="Input" Category="Pier Data" />
  <P N="ExtensionR" V="158" D="Right Sloped Section" Role="Input" Category="Pier Data" />
  <P N="MinD_L" V="52" D="Right Min Depth" Role="Input" Category="Pier Data" />
  <P N="MaxD_L" V="123" D="Right Max Depth" Role="Input" Category="Pier Data" />
</O>
<O N="Pedestal" T="Group">
  <P N="PedestalTopWidth" V="14" D="Top Width of the Girder Supports" Role="Input" Category="Pedestal Data" />
  <P N="PedestalBotWidth" V="18" D="Bottom Width of the Girder Supports" Role="Input" Category="Pedestal Data" />
  <P N="PedestalL1" V="24" D="Length of Girder Support 1" Role="Input" Category="Pedestal Data" />
  <P N="PedestalL2" V="0" D="Length of Girder Support 2" Role="Input" Category="Pedestal Data" />
  <P N="PedestalDepth" V="[0,1,2,3,4]" D="Depth of Girder Supports" Role="Input" Category="Pedestal Data" />
  <P N="PedestalLocations1" V="[-180, -80, 80, 180]" D="Location of Pedestal set 1 from CL Pier" Role="Input" Category="Pedestal Data" />
  <P N="PedestalLocations2" V="[-180, -80, 80, 180]" D="Location of girder Support set 2 from left edge of deck" Role="Input" Category="Pedestal Data" />
  <P N="PedestalOffset1" V="0" D="Location of girder support set 1 from CL Cap" Role="Input" Category="Pedestal Data" />
  <P N="PedestalOffset2" V="0" D="Location of girder support set 2 from CL Cap" Role="Input" Category="Pedestal Data" />
</O>
<O N="Column and Foundation Data" T="Group">
  <P N="ColumnH" V="60" D="Column Height" Role="Input" Category="Column Data" />
  <P N="ColumnV" V="120" D="Column Width" Role="Input" Category="Column Data" />
  <P N="FootTopElev" V="-40" D="" />
  <P N="FootH" V="200" D="" />
```

```

<P N="FootV" V="200" D="" />
<P N="PierDown" V="-80" D="" />
<P N="CIDH_Dia" V="120" D="" />
<P N="CIDH_Tip" V="-500" D="" />
</O>
<O N="Internal Parameters" T="Group" />
<O T="Surface" X="PierWidth/2">
  <P N="ElvBottomLeft" V="DistanceToCrown*PCrossSlopeL-MaxD_L" />
  <P N="ElvBottomRight" V="(-DistanceToCrown+PierLength)*PCrossSlopeR-MaxD_R" />
  <P N="Thickness" V="PierWidth" />
  <O T="Point" Z="(PierLength/2-DistanceToCrown)*PCrossSlopeL" Y="-PierLength/2" />
  <O T="Point" Z="0" Y="-DistanceToCrown" />
  <O T="Point" Z="(PierLength/2+DistanceToCrown)*PCrossSlopeR" Y="PierLength/2" />
  <O T="Point" Z="(PierLength/2+DistanceToCrown)*PCrossSlopeR-MinD_R" Y="PierLength/2" />
  <O T="Point" Z="(PierLength/2+DistanceToCrown)*PCrossSlopeR-MaxD_R" Y="PierLength/2-ExtensionR"
R="ColumnRadius" />
  <O T="Point" Z="(PierLength/2+DistanceToCrown)*PCrossSlopeR-MaxD_R-ColumnExt" Y="PierLength/2-
ExtensionR" />
  <O T="Point" Z="(PierLength/2+DistanceToCrown)*PCrossSlopeR-MaxD_R-ColumnExt" Y="-
PierLength/2+ExtensionL" />
  <O T="Point" Z="(PierLength/2-DistanceToCrown)*PCrossSlopeL-MaxD_L" Y="-PierLength/2+ExtensionL"
R="ColumnRadius" />
  <O T="Point" Z="(PierLength/2-DistanceToCrown)*PCrossSlopeL-MinD_L" Y="-PierLength/2" />
</O>
<O T="Group">
  <P N="Guard" V="PedestalL1.GT.0" />
  <O T="Repeat">
    <P N="S" V="0" />
    <P N="E" V="length(PedestalLocations1)" />
    <P N="I" V="1" />
    <P N="CTRL" V="hnl" T="Text" />
    <P N="hnl" V="0" />
    <O T="Group">
      <P N="Guard" V="hnl.GT.0" />
      <O T="Group">
        <P N="Guard" V="PedestalLocations1[hnl-1].GT.DistanceToCrown" />
        <O T="ConcPedestal (BB)" Z="-(-PedestalLocations1[hnl-1]+DistanceToCrown)*PCrossSlopeL" Y="-
PedestalLocations1[hnl-1]">
          <P N="SupportSlope" V="-PCrossSlopeL" D="T" />
          <P N="SupportTopWidth" V="PedestalTopWidth" />
          <P N="SupportBotWidth" V="PedestalBotWidth" />
          <P N="SupportL" V="PedestalL1" />
          <P N="SupportDepth" V="PedestalDepth[hnl-1]" />
          <P N="DistToCrown" V="PedestalLocations1[hnl-1]-DistanceToCrown" />
        </O>
      </O>
    </O>
  </O>
  <O T="Group">
    <P N="Guard" V="PedestalLocations1[hnl-1].EQ.DistanceToCrown" />
    <O T="ConcPedestal (BB)" Z="0" Y="PedestalLocations1[hnl-1]">
      <P N="SupportSlope" V="-(PCrossSlopeR+PierDataPCrossSlopeL)/2" D="T" />
      <P N="SupportTopWidth" V="PedestalTopWidth" />
      <P N="SupportBotWidth" V="PedestalBotWidth" />
      <P N="SupportL" V="PedestalL1" />
      <P N="SupportDepth" V="PedestalDepth[hnl-1]" />
      <P N="DistToCrown" V="-PedestalLocations1[hnl-1]+DistanceToCrown" />
    </O>
  </O>
</O>

```

```

</O>
<O T="Group">
  <P N="Guard" V="PedestalLocations1[hnl-1].LT.DistanceToCrown" />
  <O T="ConcPedestal (BB)" Z="- (PedestalLocations1[hnl-1]-DistanceToCrown)*PCrossSlopeR" Y="-
PedestalLocations1[hnl-1]">
    <P N="SupportSlope" V="PCrossSlopeR" D="T" />
    <P N="SupportTopWidth" V="PedestalTopWidth" />
    <P N="SupportBotWidth" V="PedestalBotWidth" />
    <P N="SupportL" V="PedestalL1" />
    <P N="SupportDepth" V="PedestalDepth[hnl-1]" />
    <P N="DistToCrown" V="PedestalLocations1[hnl-1]-DistanceToCrown" />
  </O>
</O>
</O>
<O T="Group">
  <P N="Guard" V="PedestalL2.GT.0" />
  <O T="Repeat">
    <P N="S" V="0" />
    <P N="E" V="length(PedestalLocations2)" />
    <P N="I" V="1" />
    <P N="CTRL" V="hnl" T="Text" />
    <P N="hnl" V="0" />
  <O T="Group">
    <P N="Guard" V="hnl.GT.0" />
    <O T="Group">
      <P N="Guard" V="PedestalLocations2[hnl-1].GT.DistanceToCrown" />
      <O T="ConcPedestal (BB)" Z="- (-PedestalLocations2[hnl-1]+DistanceToCrown)*PCrossSlopeL" Y="-
PedestalLocations2[hnl-1]">
        <P N="SupportSlope" V="-PCrossSlopeL" D="T" />
        <P N="SupportTopWidth" V="PedestalTopWidth" />
        <P N="SupportBotWidth" V="PedestalBotWidth" />
        <P N="SupportL" V="PedestalL2" />
        <P N="SupportDepth" V="PedestalDepth[hnl-1]" />
        <P N="DistToCrown" V="PedestalLocations2[hnl-1]-DistanceToCrown" />
      </O>
    </O>
  </O>
  <O T="Group">
    <P N="Guard" V="PedestalLocations2[hnl-1].EQ.DistanceToCrown" />
    <O T="ConcPedestal (BB)" Z="0" Y="PedestalLocations2[hnl-1]">
      <P N="SupportSlope" V="- (PCrossSlopeR+PCrossSlopeL)/2" D="T" />
      <P N="SupportTopWidth" V="PedestalTopWidth" />
      <P N="SupportBotWidth" V="PedestalBotWidth" />
      <P N="SupportL" V="PedestalL2" />
      <P N="SupportDepth" V="PedestalDepth[hnl-1]" />
      <P N="DistToCrown" V="-PedestalLocations2[hnl-1]+DistanceToCrown" />
    </O>
  </O>
  <O T="Group">
    <P N="Guard" V="PedestalLocations2[hnl-1].LT.DistanceToCrown" />
    <O T="ConcPedestal (BB)" Z="- (PedestalLocations2[hnl-1]-DistanceToCrown)*PCrossSlopeR" Y="-
PedestalLocations2[hnl-1]">
      <P N="SupportSlope" V="PCrossSlopeR" D="T" />
      <P N="SupportTopWidth" V="PedestalTopWidth" />
      <P N="SupportBotWidth" V="PedestalBotWidth" />
      <P N="SupportL" V="PedestalL2" />
    </O>
  </O>

```

```
<P N="SupportDepth" V="PedestalDepth[hnl-1]" />  
<P N="DistToCrown" V="PedestalLocations2[hnl-1]-DistanceToCrown" />  
</O>  
</O>  
</O>  
</O>  
</O>  
</O>  
</O>
```

## Pot Bearing

|Pot Bearing| is a simplified bearing system which uses a masonry base plate, pot and piston, and a top sole plate. The sole plate can vary in thickness based on the slope of the bottom of the girders that it supports.

Pot Bearing BY BENJAMIN BLASEN

Parameters ▾

Refresh

<div style="border: 1px solid #ccc; padding: 2px; margin-bottom: 5px;"> <small>W Width of the masonry plate (B), in.</small>  <div style="text-align: center; border: 1px solid #ccc; padding: 2px;">16.75</div> </div>	<div style="border: 1px solid #ccc; padding: 2px; margin-bottom: 5px;"> <small>h Length of the masonry plate (C), in.</small>  <div style="text-align: center; border: 1px solid #ccc; padding: 2px;">34.5</div> </div>	<div style="border: 1px solid #ccc; padding: 2px; margin-bottom: 5px;"> <small>t Thickness of the masonry plate (A), in.</small>  <div style="text-align: center; border: 1px solid #ccc; padding: 2px;">2.625</div> </div>
<div style="border: 1px solid #ccc; padding: 2px; margin-bottom: 5px;"> <small>D Distance of bolt holes from CL (D), in.</small>  <div style="text-align: center; border: 1px solid #ccc; padding: 2px;">14.625</div> </div>	<div style="border: 1px solid #ccc; padding: 2px; margin-bottom: 5px;"> <small>d Diameter of bolt holes, in.</small>  <div style="text-align: center; border: 1px solid #ccc; padding: 2px;">1</div> </div>	<div style="border: 1px solid #ccc; padding: 2px; margin-bottom: 5px;"> <small>C Bearing depth of piston compression, in.</small>  <div style="text-align: center; border: 1px solid #ccc; padding: 2px;">0.75</div> </div>
<div style="border: 1px solid #ccc; padding: 2px; margin-bottom: 5px;"> <small>Sta x-Station</small>  <div style="text-align: center; border: 1px solid #ccc; padding: 2px;">0</div> </div>	<div style="border: 1px solid #ccc; padding: 2px; margin-bottom: 5px;"> <small>nR Number of rows of bolt holes.</small>  <div style="text-align: center; border: 1px solid #ccc; padding: 2px;">2</div> </div>	<div style="border: 1px solid #ccc; padding: 2px; margin-bottom: 5px;"> <small>nB Number of equally spaced bolts per row.</small>  <div style="text-align: center; border: 1px solid #ccc; padding: 2px;">2</div> </div>
<div style="border: 1px solid #ccc; padding: 2px; margin-bottom: 5px;"> <small>Cl Clearance of holes from edges (C/2-D).</small>  <div style="text-align: center; border: 1px solid #ccc; padding: 2px;"> <math>\frac{h}{2} - D = 2.625</math> </div> </div>	<div style="border: 1px solid #ccc; padding: 2px; margin-bottom: 5px;"> <small>Thickness Masonry plate thickness.</small>  <div style="text-align: center; border: 1px solid #ccc; padding: 2px;">t = 2.625</div> </div>	<div style="border: 1px solid #ccc; padding: 2px; margin-bottom: 5px;"> <small>M Pot diameter.</small>  <div style="text-align: center; border: 1px solid #ccc; padding: 2px;">14.875</div> </div>
<div style="border: 1px solid #ccc; padding: 2px; margin-bottom: 5px;"> <small>J Sole plate length.</small>  <div style="text-align: center; border: 1px solid #ccc; padding: 2px;">21.5</div> </div>	<div style="border: 1px solid #ccc; padding: 2px; margin-bottom: 5px;"> <small>K Sole plate width.</small>  <div style="text-align: center; border: 1px solid #ccc; padding: 2px;">24</div> </div>	

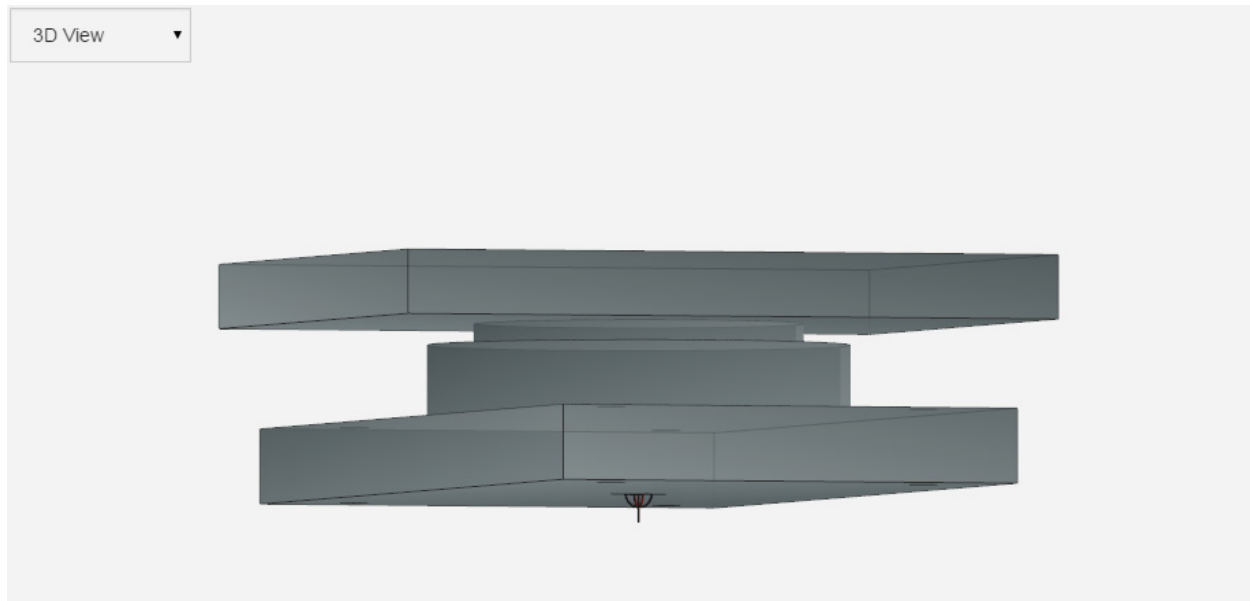

### ParamML Code

```

<O N="Pot Bearing" T="Project">
  <P N="Opacity" V="0.9" />
  <O N="ObjDesc" T="Group">
    <!--
    <p> |Pot Bearing| is a simplified bearing system which shows a masonry base plate,
  
```

the pot & piston, and a top sole plate. The default total thickness of the system is 8.1875 inches.

</p>

-->

<!--<p>

<i>Created <b>Benjamin Blasen</b> on 7/20/2015 </i>

</p>-->

<!--<p>

Limitations:

<br>1) Does not include gaskets</br>

<br>2) Only the masonry base plate is variable based on user input.</br>

</p>-->

</O>

<O N="Parameters" T="Group">

<P N="EndUserInputFields" V="1" />

<P N="w" V="16.75" D="Width of the masonry plate (B), in." Role="Input" Category="Parameters" />

<P N="h" V="34.5" D="Length of the masonry plate (C), in." Role="Input" Category="Parameters" />

<P N="t" V="2.625" D="Thickness of the masonry plate (A), in." Role="Input" Category="Parameters" />

<P N="D" V="14.625" D="Distance of bolt holes from CL (D), in." Role="Input" Category="Parameters" />

<P N="d" V="1.00" D="Diameter of bolt holes, in." Role="Input" Category="Parameters" />

<P N="c" V="0.75" D="Bearing depth of piston compression, in." Role="Input" Category="Parameters" />

<P N="Sta" V="0" D="x-Station" Role="Input" Category="Parameters" />

</O>

<O N="PotBearing" T="Group">

<O N="MASONRY" T="Surface">

<P N="nr" V="2" D="Number of rows of bolt holes." Role="Input" Category="Parameters" />

<P N="nb" V="2" D="Number of equally spaced bolts per row." Role="Input" Category="Parameters" />

<P N="cl" V="h/2-D" D="Clearance of holes from edges (C/2-D)." Role="Input" Category="Parameters" />

<P N="Thickness" V="t" D="Masonry plate thickness." Role="Input" Category="Parameters" />

<P N="spX" V="(w-cl\*2)/(nb-1)" D="spacing between bolt holes along X direction" />

<P N="spY" V="(h-cl\*2)/(nr-1)" D="spacing between bolt holes along Y direction" />

<O T="Point" X="-w/2" Y="-h/2" Z="0" />

<O T="Point" X="w/2" Y="-h/2" Z="0" />

<O T="Point" X="w/2" Y="h/2" Z="0" />

<O T="Point" X="-w/2" Y="h/2" Z="0" />

<O T="Repeat" S="0" I="1" E="nr-1" CTRL="j" j="0">

<O T="Repeat" S="0" I="1" E="nb-1" CTRL="i" i="0">

<P N="locX" V="-w/2 + cl + spX \* i" D="X location of the bolt hole" />

<P N="locY" V="-h/2 + cl + spY \* j" D="Y location of the bolt hole" />

<O T="Circle" X="locX" Y="locY">

<P N="IsCutout" V="1" />

<P N="Segments" V="20" />

<P N="Radius" V="d/2" />

</O>

</O>

</O>

</O>

<O N="POT" T="Volume" Z="t">

<P N="M" V="14.875" D="Pot diameter." Role="Input" Category="Parameters" />

<O T="Circle" Z="2.5625">

<P N="Radius" V="M/2" />

</O>

<O T="Circle" Z="0">

<P N="Radius" V="M/2" />

</O>

</O>

```

<O N="PISTON" T="Volume" Z="t+2.5625">
  <P N="V" V="11.605" />
  <O T="Circle" Z="1.5-c">
    <P N="Radius" V="V/2" />
  </O>
  <O T="Circle" Z="-.75">
    <P N="Radius" V="V/2" />
  </O>
</O>
<O N="SOLEPLATE" T="Volume" Z="t+2.5625+1.5-c" RZ="Pi/2">
  <P N="J" V="21.5" D="Sole plate length." Role="Input" Category="Parameters" />
  <P N="K" V="24" D="Sole plate width." Role="Input" Category="Parameters" />
  <P N="adjV" V="alignV(Alignment,Sta-K/2)-alignV(Alignment,Sta+K/2)" />
  <O N="A" T="Surface">
    <O T="Point" X="-J/2" Y="-K/2" Z="0" />
    <O T="Point" X="J/2" Y="-K/2" Z="0" />
    <O T="Point" X="J/2" Y="K/2" Z="0" />
    <O T="Point" X="-J/2" Y="K/2" Z="0" />
  </O>
  <O N="B" T="Surface">
    <O T="Point" X="-J/2" Y="-K/2" Z="2.25" />
    <O T="Point" X="J/2" Y="-K/2" Z="2.25" />
    <O T="Point" X="J/2" Y="K/2" Z="2.25-adjV" />
    <O T="Point" X="-J/2" Y="K/2" Z="2.25-adjV" />
  </O>
</O>
<O T="Private">
  <O N="Reference" T="InsertionPoint" Size="1" />
</O>
</O>
<O N="Elev from 3D" T="CADDFrom3D" RX="Pi/2" RZ="Pi/2">
  <P N="Obj3D" V="PotBearing" T="Group" />
</O>
</O>

```





## OregonBulbT

open BrIM OregonBulbT BY MICHAEL BARTHOLOMEW

Refresh Params ▾

W_tf Top flange width, in 4	W Bottom flange width, in 2	h overall depth, in 6.25
t_ft_e Top flange thickness (edge) 0.1667	t_ft_w Top flange thickness (web) 0.3333	t_fb_e Bottom flange thickness (edge) 0.5
t_fb_w Bottom flange thickness (web) 0.75	b_w width of web, in 0.5	Fillet Top fillet, in 0.1667
Chamfer Bottom Chamfer, in 0.0833		

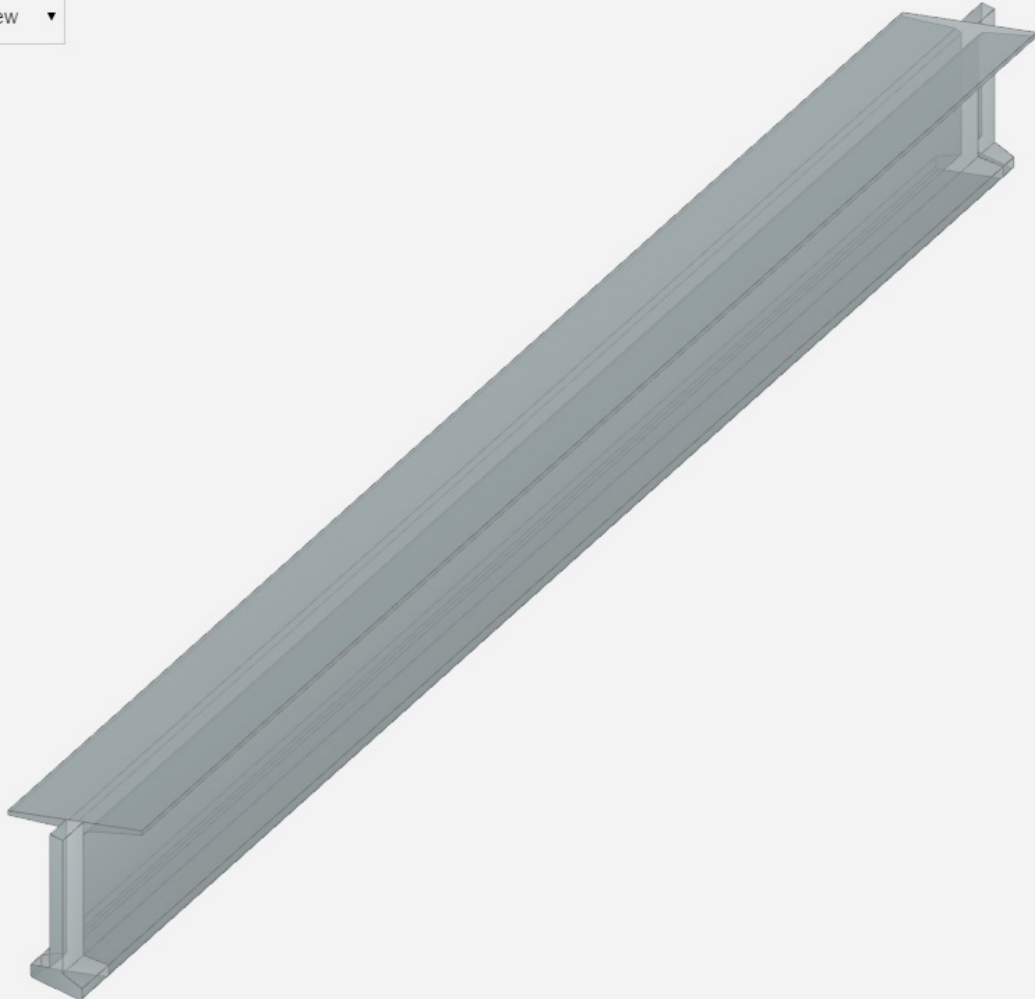
3D View ▾

ParamML Code

```

<O N="OregonBulbT" T="Project">
  <!-- created by Mike Bartholomew on 12/18/2015 -->
  <O N="Oregon Std Bulb-T Beam" T="Section">
    <P N="w_tf" V="4" D="Top flange width, in " Role="Input" />
    <P N="w" V="2" D="Bottom flange width, in " Role="Input" />
    <P N="h" V="6.25" D="overall depth, in " Role="Input" />
    <P N="t_ft_e" V="0.16666667" D="Top flange thickness (edge)" Role="Input" />
    <P N="t_ft_w" V="0.33333333" D="Top flange thickness (web)" Role="Input" />
    <P N="t_fb_e" V="0.5" D="Bottom flange thickness (edge)" Role="Input" />
    <P N="t_fb_w" V="0.75" D="Bottom flange thickness (web)" Role="Input" />
    <P N="b_w" V="0.5" D="width of web, in " Role="Input" />
    <P N="Fillet" V="0.16666667" D="Top fillet, in " Role="Input" />
    <P N="Chamfer" V="0.08333333" D="Bottom Chamfer, in " Role="Input" />
  <O N="Full Section" T="Section">
    <O T="Point" X="w_tf/2" Y="0" />
    <O T="Point" X="w_tf/2" Y="-t_ft_e" />
    <O T="Point" X="b_w/2+Fillet" Y="-t_ft_w" />
    <O T="Point" X="b_w/2" Y="-t_ft_w-Fillet" />
    <O T="Point" X="b_w/2" Y="-h+t_fb_w" />
    <O T="Point" X="w/2" Y="-h+t_fb_e" />
    <O T="Point" X="w/2" Y="-h+Chamfer" />
    <O T="Point" X="w/2-Chamfer" Y="-h" />
    <O T="Point" X="-w/2+Chamfer" Y="-h" />
    <O T="Point" X="-w/2" Y="-h+Chamfer" />
    <O T="Point" X="-w/2" Y="-h+t_fb_e" />
    <O T="Point" X="-b_w/2" Y="-h+t_fb_w" />
    <O T="Point" X="-b_w/2" Y="-t_ft_w-Fillet" />
    <O T="Point" X="-b_w/2-Fillet" Y="-t_ft_w" />
    <O T="Point" X="-w_tf/2" Y="-t_ft_e" />
    <O T="Point" X="-w_tf/2" Y="0" />
  </O>
  <O N="End Section" T="Section">
    <O T="Point" X="b_w/2" Y="0" />
    <O T="Point" X="b_w/2" Y="-h+t_fb_w" />
    <O T="Point" X="w/2" Y="-h+t_fb_e" />
    <O T="Point" X="w/2" Y="-h+Chamfer" />
    <O T="Point" X="w/2-Chamfer" Y="-h" />
    <O T="Point" X="-w/2+Chamfer" Y="-h" />
    <O T="Point" X="-w/2" Y="-h+Chamfer" />
    <O T="Point" X="-w/2" Y="-h+t_fb_e" />
    <O T="Point" X="-b_w/2" Y="-h+t_fb_w" />
    <O T="Point" X="-b_w/2" Y="0" />
  </O>
</O>
<O N="Girder 1" T="Group">
  <O T="Line">
    <P N="StartSkewX" V="0" />
    <P N="EndSkewX" V="-0.4" />
    <P N="Section" V="End Section" T="Section" />
    <P N="Opacity" V="0.7" />
    <P N="DrawBorder" V="1" />
    <P N="DrawFaceA" V="1" />
    <P N="DrawFaceB" V="1" />
    <P N="DrawFaceBBorder" V="1" />
  </O>

```

```

    <O T="Point" X="0" Y="0" Z="0" />
    <O T="Point" X="1" Y="0" Z="0" />
</O>
<O T="Line">
  <P N="StartSkewX" V="-0.4" />
  <P N="EndSkewX" V="-0.4" />
  <P N="Section" V="Full Section" T="Section" />
  <P N="Opacity" V="0.7" />
  <P N="DrawBorder" V="1" />
  <P N="DrawFaceA" V="1" />
  <P N="DrawFaceB" V="1" />
  <P N="DrawFaceABorder" V="1" />
  <P N="DrawFaceBBorder" V="1" />
  <O T="Point" X="1" Y="0" Z="0" />
  <O T="Point" X="49" Y="0" Z="0" />
</O>
<O T="Line">
  <P N="StartSkewX" V="-0.4" />
  <P N="EndSkewX" V="0" />
  <P N="Section" V="End Section" T="Section" />
  <P N="Opacity" V="0.7" />
  <P N="DrawBorder" V="1" />
  <P N="DrawFaceA" V="1" />
  <P N="DrawFaceB" V="1" />
  <P N="DrawFaceABorder" V="1" />
  <O T="Point" X="49" Y="0" Z="0" />
  <O T="Point" X="50" Y="0" Z="0" />
</O>
</O>
</O>

```

**Std Box Beam**

[Std Box Beam (BB)] library object based on NY State DOT standard for adjacent box beams. Beams are hollow and have intermediate and end diaphragms.

Limitations:

- 1) Girders must be straight.
- 2) Girders must have the same skew at beginning and end.
- 3) Alignment may contain curves, however the piers must be parallel.
- 4) There must be a least one interior diaphragm.

open BrIM Std Box Beam (BB) BY BENJAMIN BLASEN

Refresh

Girder Cross Section Data

W overall width, in	48	h overall depth, in	36	t_ft Top flange thickness, in	5.5
t_fb Bottom flange thickness, in	5.5	b_W width of web, in	5	Fillet Inside fillet, in	3
h_KeyT Top key height, in	4	w_KeyT Top key width, in	0.375	h_KeyB Bottom key height, in	4
w_KeyB Bottom key width, in	0.75				

open BrIM Std Box Beam (BB) BY BENJAMIN BLASEN

Refresh

Girder Span Data

StartOffset X-Coordinate Offset from Start	24	EndOffset X-Coordinate Offset from End	24	Length Length of girder span, in.	960
GirderSkew Girder Skew Angle, rad.	0.393	CLBearingToBeamEnd Length of Centerline of Bearing to Beam End, in.	10	EndBeamThick End Beam Thickness (end to start of hollow section), in.	24
NumIntDiaph Number of Interior Diaphragms	3	IntDiaphThick Thickness of Interior Diaphragms, in.	18		

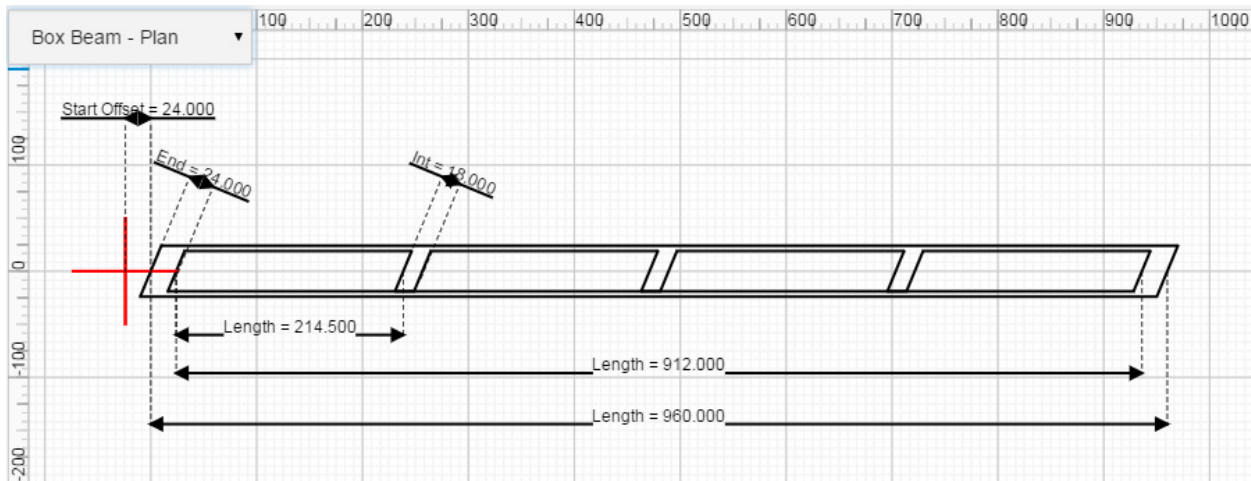
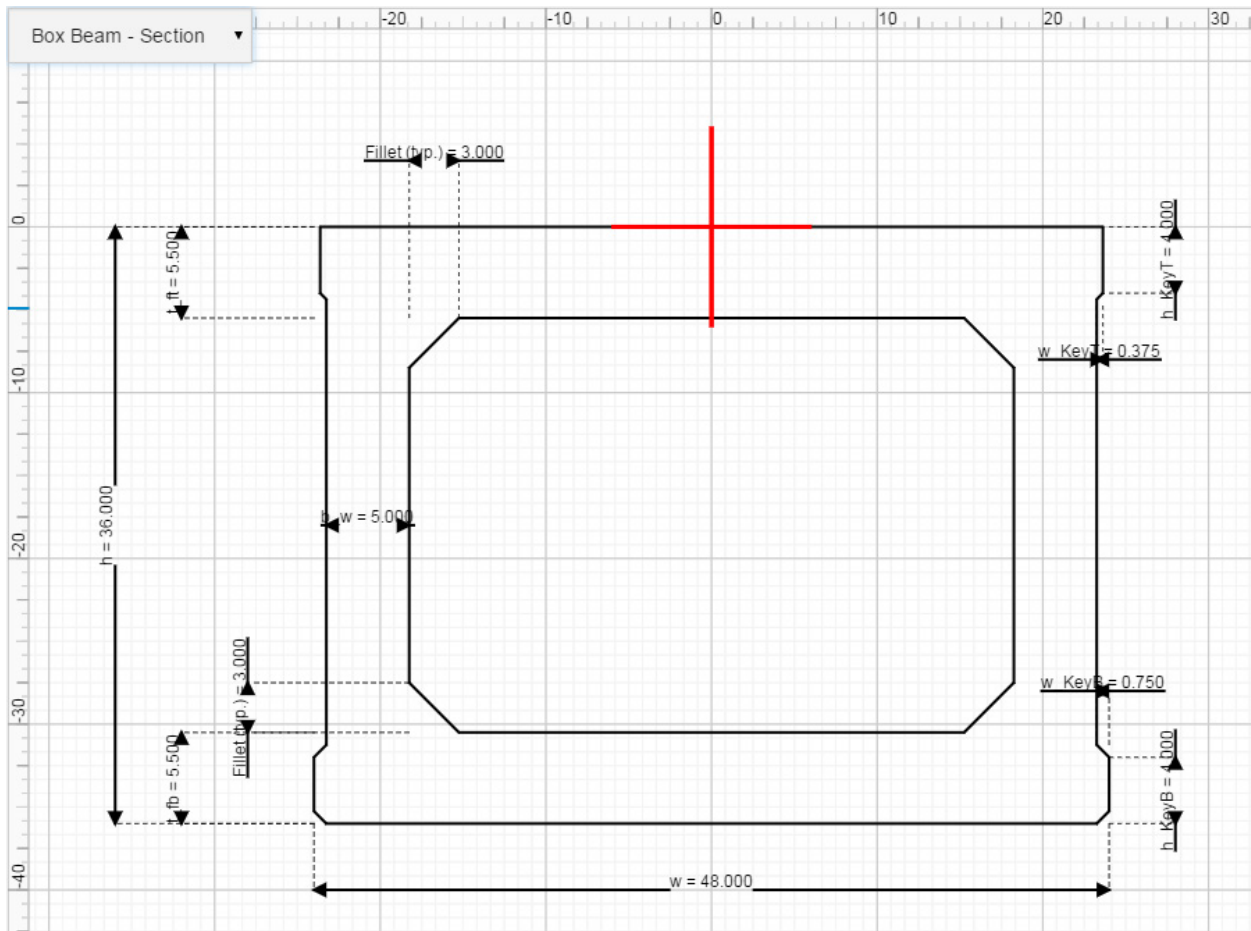

ParamML Code

```
O N="Std Box Beam (BB)" T="Project">
  <O N="ObjDesc" T="Group">
    <!--<p> |Std Box Beam (BB)| library object. </p> -->
    <!-- <i>created by <b>Mike Bartholomew</b> on 6/2/2015</i> -->
    <!-- <i>updated by <b>Benjamin Blasen</b> on 7/6/2015</i> -->
    <!--
    <br>Limitations:</br>
```

```

<br>1) Girders must be straight.</br>
<br>2) Girders must have the same skew at beginning and end.</br>
<br>3) Alignment may contain curves, however the piers must be parallel.</br>
<br>4) There must be a least one interior diaphragm.</br>
-->
</O>
<O N="Girder Cross Section Data" T="Group">
  <P N="w" V="48" D="overall width, in " Role="Input" Category="Girder Cross Section Data" />
  <P N="h" V="36" D="overall depth, in " Role="Input" Category="Girder Cross Section Data" />
  <P N="t_ft" V="5.5" D="Top flange thickness, in " Role="Input" Category="Girder Cross Section Data" />
  <P N="t_fb" V="5.5" D="Bottom flange thickness, in " Role="Input" Category="Girder Cross Section Data" />
  <P N="b_w" V="5" D="width of web, in " Role="Input" Category="Girder Cross Section Data" />
  <P N="Fillet" V="3" D="Inside fillet, in " Role="Input" Category="Girder Cross Section Data" />
  <P N="h_KeyT" V="4" D="Top key height, in " Role="Input" Category="Girder Cross Section Data" />
  <P N="w_KeyT" V="0.375" D="Top key width, in " Role="Input" Category="Girder Cross Section Data" />
  <P N="h_KeyB" V="4" D="Bottom key height, in " Role="Input" Category="Girder Cross Section Data" />
  <P N="w_KeyB" V="0.75" D="Bottom key width, in " Role="Input" Category="Girder Cross Section Data" />
</O>
<O N="Girder Span Data" T="Group">
  <P N="StartOffset" V="24" D="X-Coordinate Offset from Start" Role="Input" Category="Girder Span Data" />
  <P N="EndOffset" V="24" D="X-Coordinate Offset from End" Role="Input" Category="Girder Span Data" />
  <P N="Length" V="960" D="Length of girder span, in." Role="Input" Category="Girder Span Data" />
  <P N="GirderSkew" V="0.393" D="Girder Skew Angle, rad." Role="Input" Category="Girder Span Data" />
  <P N="CLBearingToBeamEnd" V="10" D="Length of Centerline of Bearing to Beam End, in." Role="Input"
Category="Girder Span Data" />
  <P N="EndBeamThick" V="24" D="End Beam Thickness (end to start of hollow section), in." Role="Input"
Category="Girder Span Data" />
  <P N="NumIntDiaph" V="3" D="Number of Interior Diaphragms" Role="Input" Category="Girder Span Data" />
  <P N="IntDiaphThick" V="18" D="Thickness of Interior Diaphragms, in." Role="Input" Category="Girder Span
Data" />
</O>
<O N="Hollow Box Beam" T="Section">
  <O N="Solid" T="Shape">
    <O T="Point" Y="0" X="-w/2+w_KeyB-w_KeyT" />
    <O T="Point" Y="-h_KeyT" X="-w/2+w_KeyB-w_KeyT" />
    <O T="Point" Y="-h_KeyT-w_KeyT" X="-w/2+w_KeyB" />
    <O T="Point" Y="-h+h_KeyB+w_KeyB" X="-w/2+w_KeyB" />
    <O T="Point" Y="-h+h_KeyB" X="-w/2" />
    <O T="Point" Y="-h+w_KeyB" X="-w/2" />
    <O T="Point" Y="-h" X="-w/2+w_KeyB" />
    <O T="Point" Y="-h" X="w/2-w_KeyB" />
    <O T="Point" Y="-h+w_KeyB" X="w/2" />
    <O T="Point" Y="-h+h_KeyB" X="w/2" />
    <O T="Point" Y="-h+h_KeyB+w_KeyB" X="w/2-w_KeyB" />
    <O T="Point" Y="-h_KeyT-w_KeyT" X="w/2-w_KeyB" />
    <O T="Point" Y="-h_KeyT" X="w/2-w_KeyB+w_KeyT" />
    <O T="Point" Y="0" X="w/2-w_KeyB+w_KeyT" />
  </O>
  <O N="Void" T="Shape">
    <P N="IsCutout" V="1" />
    <P N="DrawBorder" V="1" />
    <O T="Point" Y="-t_fb" X="-w/2+w_KeyB+b_w+Fillet" />
    <O T="Point" Y="-t_fb-Fillet" X="-w/2+w_KeyB+b_w" />
    <O T="Point" Y="-h+t_ft+Fillet" X="-w/2+w_KeyB+b_w" />
    <O T="Point" Y="-h+t_ft" X="-w/2+w_KeyB+b_w+Fillet" />
    <O T="Point" Y="-h+t_ft" X="w/2-w_KeyB-b_w-Fillet" />
  </O>

```

```

    <O T="Point" Y="-h+t_ft+Fillet" X="w/2-w_KeyB-b_w" />
    <O T="Point" Y="-t_fb-Fillet" X="w/2-w_KeyB-b_w" />
    <O T="Point" Y="-t_fb" X="w/2-w_KeyB-b_w-Fillet" />
  </O>
</O>
<O N="Girder 1" T="Line">
  <P N="StartSkewX" V="GirderSkew" />
  <P N="EndSkewX" V="GirderSkew" />
  <P N="StartOffsetX" V="StartOffset" />
  <P N="EndOffsetX" V="-1*EndOffset" />
  <P N="Opacity" V="0.75" />
  <P N="BetaAngle" V="0" />
  <O T="Point" Z="0" Y="0" X="0" />
  <O N="Solid" T="Shape" Extends="Solid" />
  <O T="Point" X="EndBeamThick/cos(GirderSkew)/Length" />
  <O N="Hollow Box Beam" T="Section" Extends="Hollow Box Beam" />
  <O T="Repeat">
    <P N="S" V="1" />
    <P N="E" V="NumIntDiaph" />
    <P N="I" V="1" />
    <P N="CTRL" V="index" T="Text" />
    <P N="index" V="1" />
    <O T="Point" X="index/(E+1)-0.5*IntDiaphThick/cos(GirderSkew)/(Length-EndBeamThick)" />
    <O N="Solid" T="Shape" Extends="Solid" />
    <O T="Point" X="index/(E+1)+0.5*IntDiaphThick/cos(GirderSkew)/(Length-EndBeamThick)" />
    <O N="Hollow Box Beam" T="Section" Extends="Hollow Box Beam" />
  </O>
  <O T="Point" X="1-EndBeamThick/cos(GirderSkew)/Length" />
  <O N="Solid" T="Shape" Extends="Solid" />
  <O T="Point" Z="0" Y="0" X="Length" />
</O>
<O T="Private">
  <O N="Top Chord Working Line" T="Line">
    <P N="BetaAngle" V="0" />
    <P N="Color" V="#FF0000" T="Text" />
    <O N="Simple Line" T="Section">
      <P N="w" V="0.1" />
      <P N="h" V="0.1" />
      <O T="Shape">
        <O T="Point" X="-w/2" Y="-h/2" />
        <O T="Point" X="w/2" Y="-h/2" />
        <O T="Point" X="w/2" Y="h/2" />
        <O T="Point" X="-w/2" Y="h/2" />
      </O>
    </O>
    <O T="Point" Z="0" Y="0" X="0" />
    <O T="Point" Z="0" Y="0" X="Length" />
  </O>
</O>
<O N="Box Beam - Section" T="CADD">
  <P N="margin" V="2" />
  <O T="CADDShape" Y="0" X="0" RZ="0">
    <P N="Color" V="rgb(0, 0, 0)" T="Text" />
    <P N="Thickness" V="2" />
    <P N="IsClosed" V="T" T="Text" />
    <O T="Point" Y="0" X="-w/2+w_KeyB-w_KeyT" />

```

```

<O T="Point" Y="-h_KeyT" X="-w/2+w_KeyB-w_KeyT" />
<O T="Point" Y="-h_KeyT-w_KeyT" X="-w/2+w_KeyB" />
<O T="Point" Y="-h+h_KeyB+w_KeyB" X="-w/2+w_KeyB" />
<O T="Point" Y="-h+h_KeyB" X="-w/2" />
<O T="Point" Y="-h+w_KeyB" X="-w/2" />
<O T="Point" Y="-h" X="-w/2+w_KeyB" />
<O T="Point" Y="-h" X="w/2-w_KeyB" />
<O T="Point" Y="-h+w_KeyB" X="w/2" />
<O T="Point" Y="-h+h_KeyB" X="w/2" />
<O T="Point" Y="-h+h_KeyB+w_KeyB" X="w/2-w_KeyB" />
<O T="Point" Y="-h_KeyT-w_KeyT" X="w/2-w_KeyB" />
<O T="Point" Y="-h_KeyT" X="w/2-w_KeyB+w_KeyT" />
<O T="Point" Y="0" X="w/2-w_KeyB+w_KeyT" />
</O>
<O T="CADDShape" Y="0" X="0" RZ="0">
  <P N="Color" V="rgb(0,0,0)" T="Text" />
  <P N="Thickness" V="2" />
  <P N="IsClosed" V="T" T="Text" />
  <O T="Point" Y="-t_fb" X="-w/2+w_KeyB+b_w+Fillet" />
  <O T="Point" Y="-t_fb-Fillet" X="-w/2+w_KeyB+b_w" />
  <O T="Point" Y="-h+t_ft+Fillet" X="-w/2+w_KeyB+b_w" />
  <O T="Point" Y="-h+t_ft" X="-w/2+w_KeyB+b_w+Fillet" />
  <O T="Point" Y="-h+t_ft" X="w/2-w_KeyB-b_w-Fillet" />
  <O T="Point" Y="-h+t_ft+Fillet" X="w/2-w_KeyB-b_w" />
  <O T="Point" Y="-t_fb-Fillet" X="w/2-w_KeyB-b_w" />
  <O T="Point" Y="-t_fb" X="w/2-w_KeyB-b_w-Fillet" />
</O>
<O T="CADDLine">
  <P N="Color" V="#FF0000" T="Text" />
  <P N="Thickness" V="3" />
  <O T="Point" X="0" Y="-6" />
  <O T="Point" X="0" Y="6" />
</O>
<O T="CADDLine">
  <P N="Color" V="#FF0000" T="Text" />
  <P N="Thickness" V="3" />
  <O T="Point" X="6" Y="0" />
  <O T="Point" X="-6" Y="0" />
</O>
<O T="CADDDimensionLine" Y="0" X="0" RZ="0">
  <P N="Label" V="w = %d" T="Text" />
  <O T="Point" Y="-h" X="-w/2" />
  <O T="Point" Y="-h" X="w/2" />
  <O T="Point" Y="-h-margin*2" X="0" />
</O>
<O T="CADDDimensionLine" Y="0" X="0" RZ="0">
  <P N="Label" V="h = %d" T="Text" />
  <O T="Point" Y="-h" X="-w/2" />
  <O T="Point" Y="0" X="-w/2" />
  <O T="Point" Y="-h/2" X="-w/2-margin*6" />
</O>
<O T="CADDDimensionLine" Y="0" X="0" RZ="0">
  <P N="Label" V="t_ft = %d" T="Text" />
  <O T="Point" Y="-t_ft" X="-w/2" />
  <O T="Point" Y="0" X="-w/2" />
  <O T="Point" Y="-t_ft/2" X="-w/2-margin*4" />

```



```

</O>
<O T="CADDDimensionLine" Y="0" X="0" RZ="0">
  <P N="Label" V="t_fb = %d" T="Text" />
  <O T="Point" Y="-h" X="-w/2" />
  <O T="Point" Y="-h+t_fb" X="-w/2" />
  <O T="Point" Y="-h+t_ft/2" X="-w/2-margin*4" />
</O>
<O T="CADDDimensionLine" Y="0" X="0" RZ="0">
  <P N="Label" V="b_w = %d" T="Text" />
  <O T="Point" Y="-h/2" X="-w/2+w_KeyB" />
  <O T="Point" Y="-h/2" X="-w/2+b_w+w_KeyB" />
  <O T="Point" Y="-h/2" X="-w/2+b_w/2+w_KeyB" />
</O>
<O T="CADDDimensionLine" Y="0" X="0" RZ="0">
  <P N="Label" V="Fillet (typ.) = %d" T="Text" />
  <O T="Point" Y="-t_ft" X="-w/2+w_KeyB+b_w" />
  <O T="Point" Y="-t_ft" X="-w/2+w_KeyB+b_w+Fillet" />
  <O T="Point" Y="margin*2" X="-w/2+w_KeyB+b_w+Fillet/2" />
</O>
<O T="CADDDimensionLine" Y="0" X="0" RZ="0">
  <P N="Label" V="Fillet (typ.) = %d" T="Text" />
  <O T="Point" Y="-h+t_ft" X="-w/2+w_KeyB+b_w" />
  <O T="Point" Y="-h+t_ft+Fillet" X="-w/2+w_KeyB+b_w" />
  <O T="Point" Y="-h+t_ft+Fillet/2" X="-w/2-margin*2" />
</O>
<O T="CADDDimensionLine" Y="0" X="0" RZ="0">
  <P N="Label" V="h_KeyT = %d" T="Text" />
  <O T="Point" Y="-h_KeyT" X="w/2" />
  <O T="Point" Y="0" X="w/2" />
  <O T="Point" Y="-h_KeyT/2" X="w/2+margin*2" />
</O>
<O T="CADDDimensionLine" Y="0" X="0" RZ="0">
  <P N="Label" V="h_KeyB = %d" T="Text" />
  <O T="Point" Y="-h" X="w/2" />
  <O T="Point" Y="-h+h_KeyB" X="w/2" />
  <O T="Point" Y="-h+h_KeyB/2" X="w/2+margin*2" />
</O>
<O T="CADDDimensionLine" Y="0" X="0" RZ="0">
  <P N="Label" V="w_KeyB = %d" T="Text" />
  <O T="Point" Y="-h+h_KeyB+w_KeyB" X="w/2-w_KeyB" />
  <O T="Point" Y="-h+h_KeyB+w_KeyB" X="w/2" />
  <O T="Point" Y="-h+h_KeyB+margin*2" X="w/2+w_KeyB/2" />
</O>
<O T="CADDDimensionLine" Y="0" X="0" RZ="0">
  <P N="Label" V="w_KeyT = %d" T="Text" />
  <O T="Point" Y="-h_KeyT-w_KeyB" X="w/2-w_KeyB" />
  <O T="Point" Y="-h_KeyT-w_KeyB" X="w/2-w_KeyT" />
  <O T="Point" Y="-h_KeyT-margin*2" X="w/2-w_KeyT/2" />
</O>
</O>
<O N="Box Beam - Plan" T="CADD">
  <P N="margin" V="0.5" />
  <!-- creates box -->
  <O T="CADDShape" Y="0" X="0" RZ="0">
    <P N="Color" V="rgb(0, 0, 0)" T="Text" />
    <P N="Thickness" V="2" />
  </O>

```

```

<P N="IsClosed" V="T" T="Text" />
<O T="Point" Y="-w/2" X="0-w/2*tan(GirderSkew)" />
<O T="Point" Y="w/2" X="0+w/2*tan(GirderSkew)" />
<O T="Point" Y="w/2" X="Length+w/2*tan(GirderSkew)" />
<O T="Point" Y="-w/2" X="Length-w/2*tan(GirderSkew)" />
</O>
<!-- creates diaphragms -->
<O T="CADDShape" Y="0" X="0" RZ="0">
  <P N="Color" V="rgb(0, 0, 0)" T="Text" />
  <P N="Thickness" V="2" />
  <P N="IsClosed" V="T" T="Text" />
  <P N="OpenLength" V="(Length-2*EndBeamThick-IntDiaphThick*NumIntDiaph)/(NumIntDiaph+1)" />
  <P N="X1" V="EndBeamThick+(-w/2+b_w)*tan(GirderSkew)" />
  <P N="X2" V="EndBeamThick+(w/2-b_w)*tan(GirderSkew)" />
  <O T="Repeat">
    <P N="S" V="0" />
    <P N="I" V="1" />
    <P N="E" V="NumIntDiaph" />
    <P N="CTRL" V="index" T="Text" />
    <P N="index" V="0" />
    <O T="Point" Y="-w/2+b_w" X="X1 + (index * OpenLength) + (IntDiaphThick * index)" />
    <O T="Point" Y="w/2-b_w" X="X2 + (index * OpenLength) + (IntDiaphThick * index)" />
    <O T="Point" Y="w/2-b_w" X="X2+ (index+1) * OpenLength+ (IntDiaphThick * index)" />
    <O T="Point" Y="-w/2+b_w" X="X1+ (index+1) * OpenLength+ (IntDiaphThick * index)" />
  </O>
</O>
<O T="CADDLine">
  <P N="Color" V="#FF0000" T="Text" />
  <P N="Thickness" V="2" />
  <O T="Point" X="-StartOffset" Y="-50" />
  <O T="Point" X="-StartOffset" Y="50" />
</O>
<O T="CADDLine">
  <P N="Color" V="#FF0000" T="Text" />
  <P N="Thickness" V="2" />
  <O T="Point" X="-50-StartOffset" Y="0" />
  <O T="Point" X="50-StartOffset" Y="0" />
</O>
<O T="CADDDimensionLine" Y="0" X="0" RZ="0">
  <P N="Label" V="Start Offset = %d" T="Text" />
  <O T="Point" Y="-2*margin" X="-StartOffset" />
  <O T="Point" Y="-2*margin" X="0" />
  <O T="Point" Y="3*w" X="StartOffset/2" />
</O>
<O T="CADDDimensionLine" Y="0" X="0" RZ="0">
  <P N="Label" V="Length = %d" T="Text" />
  <O T="Point" Y="-2*margin" X="0" />
  <O T="Point" Y="-2*margin" X="Length" />
  <O T="Point" Y="-3*w" X="Length/2" />
</O>
<O T="CADDDimensionLine" Y="0" X="0" RZ="0">
  <P N="Label" V="Length = %d" T="Text" />
  <O T="Point" Y="-1*margin" X="EndBeamThick" />
  <O T="Point" Y="-1*margin" X="Length-EndBeamThick" />
  <O T="Point" Y="-2*w" X="Length/2" />
</O>

```

```

<O T="CADDDimensionLine" Y="0" X="0" RZ="0">
  <P N="Label" V="Length = %d" T="Text" />
  <O T="Point" Y="-1*margin" X="EndBeamThick" />
  <O T="Point" Y="-1*margin" X="EndBeamThick+OpenLength" />
  <O T="Point" Y="-1.25*w" X="Length/4" />
</O>
<O T="CADDDimensionLine" Y="0" X="0" RZ="GirderSkew">
  <P N="Label" V="End = %d" T="Text" />
  <O T="Point" Y=".5*margin" X="0" />
  <O T="Point" Y=".5*margin" X="EndBeamThick" />
  <O T="Point" Y="2*w" X="Length" />
</O>
<O T="CADDDimensionLine" Y=".5*margin" X="EndBeamThick+OpenLength" RZ="GirderSkew">
  <P N="Label" V="Int = %d" T="Text" />
  <O T="Point" Y="0" X="0" />
  <O T="Point" Y="0" X="IntDiaphThick" />
  <O T="Point" Y="2*w" X="Length" />
</O>
</O>
</O>
</O>

```

## SteelGirderMB

SteelGirderMB object is used for creating Bridge Steel Plate I-Girders. Girders can be defined as a single object for the entire length of the bridge, or as individual field sections. The cross section is comprised of a web and top and bottom flange plates. The widths and thicknesses of the plates can vary in steps along the length of the girder.

The girder also includes provisions for various types of vertical stiffeners, including shear stiffeners, cross frame connection plates, bearing stiffeners at supports, and jacking stiffeners near supports for future bearing replacement.

open BrIM SteelGirderMB by Mike Bartholomew

Refresh Girder Cross Section Data ▾

Length Length of Field Section	dW Web depth of the I girder	tW Web thickness of the I girder
1000	90	0.75
tfb Thickness of the bottom flange of the I girder	bft Width of the top flange of the I girder	tft Thickness of the top flange of the I girder
[0, 300, 1, 300, 700, 3, 700, 1000, 1]	[0, 300, 20, 300, 700, 24, 700, 1000, 20]	[0, 300, 1, 300, 700, 3, 700, 1000, 1]
bfb Width of the bottom flange of the I girder		
[0, 300, 20, 300, 700, 24, 700, 1000, 20]		

open BrIM SteelGirderMB by Mike Bartholomew

Refresh ShearStiffener ▾

WebStiffOrient Side of Web stiffened, L = Left, R = Right, B = Both N = None	WebStiffT Shear Stiffener Thickness	WebStiffW ShearStiffener Width
R	0.25	6
WebStiffHeight Shear Stiffener Height	WebStiffClipH Shear Stiffener Horizontal Clip	WebStiffClipV Shear Stiffener Vertical Clip
90	1.5	2.5
WebStiffLOC Shear Stiffener locations		
[300, 400, 500, 700, 800]		

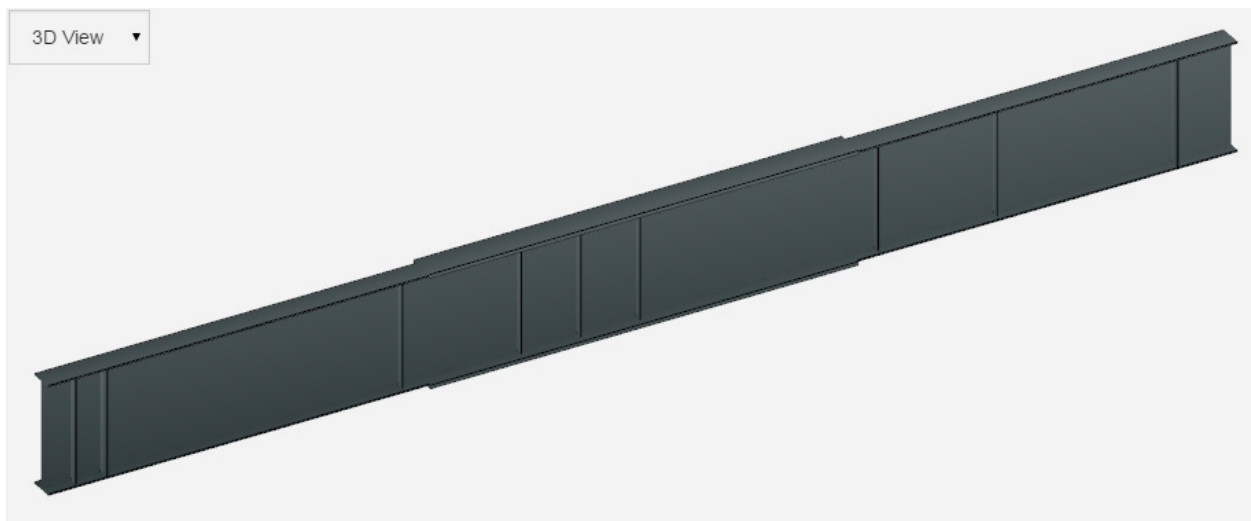

ParamML Code

```

<O N="SteelGirderMB" T="Project">
  <P N="StartStation" V="0" />
  <P N="Offset" V="0" />
  <O N="ObjDesc" T="Group">
    <!--
<p> |SteelGirderMB| object is used for creating Bridge Steel Plate I-Girders.
Girders can be defined as a single object for the entire length of the bridge,
or as individual field sections. The cross section is comprised of a web and
top and bottom flange plates. The widths and thicknesses of the plates can vary
in steps along the length of the girder. </p>
</p> The girder also includes provisions for various types of vertical
stiffeners, including shear stiffeners, cross frame connection plates,
bearing stiffeners at supports, and jacking stiffeners near supports for
future bearing replacement. </p>  <P N="Opacity" V="1" />

-->
</O>
<!-- created by Mike Bartholomew on 7/23/2015 -->
<O N="Girder Cross Section Data" T="Group">
  <P N="Length" V="1000" D="Length of Field Section" Role="Input" Category="Girder Cross Section Data" />
  <P N="dw" V="90" D="Web depth of the I girder" Role="Input" Category="Girder Cross Section Data" />
  <P N="tw" V="0.75" D="Web thickness of the I girder" Role="Input" Category="Girder Cross Section Data" />
  <P N="tfb" V="[[0,320], 1,[320,680], 3,[680,1000], 1]" D="Thickness of the bottom flange of the I girder"
Role="Input" Category="Girder Cross Section Data" />
  <P N="bft" V="[[0,320],20,[320,680],24,[680,1000],20]" D="Width of the top flange of the I girder"
Role="Input" Category="Girder Cross Section Data" />
  <P N="tft" V="[[0,320], 1,[320,680], 3,[680,1000], 1]" D="Thickness of the top flange of the I girder"
Role="Input" Category="Girder Cross Section Data" />
  <P N="bfb" V="[[0,320],20,[320,680],24,[680,1000],20]" D="Width of the bottom flange of the I girder"
Role="Input" Category="Girder Cross Section Data" /> <O N="StiffenerData" T="Group">
  <O N="ShearStiffener" T="Group">
    <P N="WebStiffOrient" V="L" T="Text" D="Side of Web stiffened, L = Left, R = Right, B = Both N = None"
Role="Input" Category="ShearStiffener" />
    <P N="WebStiffT" V="0.25" D="Shear Stiffener Thickness" Role="Input" Category="ShearStiffener" />
    <P N="WebStiffW" V="6" D="ShearStiffener Width" Role="Input" Category="ShearStiffener" />
    <P N="WebStiffHeight" V="90" D="Shear Stiffener Height" Role="Input" Category="ShearStiffener" />
    <P N="WebStiffClipH" V="1.5" D="Shear Stiffener Horizontal Clip" Role="Input" Category="ShearStiffener" />
    <P N="WebStiffClipV" V="2.5" D="Shear Stiffener Vertical Clip" Role="Input" Category="ShearStiffener" />
    <P N="WebStiffLoc" V="[300, 400, 500, 700, 800]" D="Shear Stiffener locations" Role="Input"
Category="ShearStiffener" />
  </O>
  <O N="ConnectionStiffener" T="Group">
    <P N="ConnStiffOrient" V="L" T="Text" D="Side of Web stiffened, L = Left, R = Right, B = Both N = None"
Role="Input" Category="ConnectionStiffener" />
    <P N="ConnStiffT" V="0.5" D="Connection Stiffener Thickness" Role="Input" Category="ConnectionStiffener"
/>
    <P N="ConnStiffW" V="6" D="Connection Stiffener Width" Role="Input" Category="ConnectionStiffener" />
    <P N="ConnStiffHeight" V="90" D="Connection Stiffener Height" Role="Input"
Category="ConnectionStiffener" />
    <P N="ConnStiffClipH" V="1.5" D="Connection Stiffener Horizontal Clip" Role="Input"
Category="ConnectionStiffener" />
    <P N="ConnStiffClipV" V="2.5" D="Connection Stiffener Vertical Clip" Role="Input"
Category="ConnectionStiffener" />
  </O>
</O>

```

```

    <P N="ConnStiffLoc" V="[450, 700]" D="Connection Stiffener locations" Role="Input"
Category="ConnectionStiffener" />
</O>
<O N="BearingStiffener" T="Group">
    <P N="BearingStiffOrient" V="B" T="Text" D="Side of Web stiffened, L = Left, R = Right, B = Both N = None"
Role="Input" Category="BearingStiffener" />
    <P N="BearingStiffT" V="0.75" D="Bearing Stiffener Thickness" Role="Input" Category="BearingStiffener" />
    <P N="BearingStiffW" V="7.5" D="Bearing Plate Width" Role="Input" Category="BearingStiffener" />
    <P N="BearingStiffHeight" V="90" D="Bearing Stiffener Height" Role="Input" Category="BearingStiffener" />
    <P N="BearingStiffClipH" V="1.5" D="Bearing Stiffener Horizontal Clip" Role="Input"
Category="BearingStiffener" />
    <P N="BearingStiffClipV" V="2.5" D="Bearing Stiffener Vertical Clip" Role="Input"
Category="BearingStiffener" />
    <P N="BearingStiffLoc" V="[25, 975]" D="Bearing Stiffener locations" Role="Input"
Category="BearingStiffener" />
</O>
<O N="JackingStiffener" T="Group">
    <P N="JackingStiffOrient" V="B" T="Text" D="Side of Web stiffened, L = Left, R = Right, B = Both N = None"
Role="Input" Category="JackingStiffener" />
    <P N="JackingStiffT" V="1.0" D="Jacking Stiffener Thickness" Role="Input" Category="JackingStiffener" />
    <P N="JackingStiffW" V="9" D="Jacking Stiffener Width" Role="Input" Category="JackingStiffener" />
    <P N="JackingStiffHeight" V="90" D="Jacking Stiffener Height" Role="Input" Category="JackingStiffener" />
    <P N="JackingStiffClipH" V="1.5" D="Jacking Stiffener Horizontal Clip" Role="Input"
Category="JackingStiffener" />
    <P N="JackingStiffClipV" V="2.5" D="Jacking Stiffener Vertical Clip" Role="Input" Category="JackingStiffener"
/>
    <P N="JackingStiffLoc" V="[50,950]" D="Jacking Stiffener locations" Role="Input" Category="JackingStiffener"
/>
</O>
</O>
<!--
-->
<O N="Internal Drawing Parameters" T="Group">
    <P N="L" V="L" T="Text" D="Used for Left Side Stiffener only" />
    <P N="R" V="R" T="Text" D="Used for Right Side Stiffener only" />
    <P N="B" V="B" T="Text" D="Used for Both Sides Stiffener" />
</O>
<O N="GirderFieldSection" T="Group">
    <O N="IGirder" T="Section">
        <O N="Top Flange" T="Shape">
            <P N="Material" V="STEEL" T="Material" D="Material" />
            <O T="Point" Y="tft" X="-bft/2" />
            <O T="Point" Y="tft" X="bft/2" />
            <O T="Point" Y="0" X="bft/2" />
            <O T="Point" Y="0" X="-bft/2" />
        </O>
        <O N="Web" T="Shape">
            <P N="Material" V="STEEL" T="Material" D="Material" />
            <O T="Point" Y="0" X="tw/2" />
            <O T="Point" Y="-dw" X="tw/2" />
            <O T="Point" Y="-dw" X="-tw/2" />
            <O T="Point" Y="0" X="-tw/2" />
        </O>
        <O N="Bottom Flange" T="Shape">
            <P N="Material" V="STEEL" T="Material" D="Material" />
            <O T="Point" Y="-dw" X="bfb/2" />

```

```

    <O T="Point" Y="-dw-tfb" X="bfb/2" />
    <O T="Point" Y="-dw-tfb" X="-bfb/2" />
    <O T="Point" Y="-dw" X="-bfb/2" />
  </O>
</O>
<O T="Line">
  <P N="Section" V="IGirder" T="Section" />
  <O T="Point" Y="0" X="0" Z="0" />
  <O T="Point" Y="0" X="Length" Z="0" />
</O>
<!-- Draw Web Stiffeners -->
<O N="Shear Stiffeners" T="Group">
  <P N="Guard" V="WebStiffOrient.NE.None" />
  <O T="Repeat">
    <P N="S" V="1" />
    <P N="E" V="length(WebStiffLoc)" />
    <P N="I" V="1" />
    <P N="CTRL" V="spi" T="Text" />
    <P N="spi" V="0" />
    <O N="Draw Right" T="Group">
      <P N="Guard" V="(WebStiffOrient.EQ.R).OR.(WebStiffOrient.EQ.B)" />
      <P N="CL" V="alignT(Alignment, StartStation+WebStiffLoc[spi-1], Offset)" />
      <P N="GR" V="alignT(Alignment, StartStation+WebStiffLoc[spi-1], Offset+tw/2+WebStiffW/2)" />
      <P N="AdjR" V="CL-GR" />
      <O T="VerticalStiffener" Y="tw/2" X="WebStiffLoc[spi-1]" Z="AdjR" AlignH="Warp" AlignV="Orient">
        <P N="t" V="WebStiffT" D="Thickness" />
        <P N="w" V="WebStiffW" D="Width" />
        <P N="h" V="WebStiffHeight" D="Height" />
        <P N="clipV" V="WebStiffClipV" D="Vertical clip height" />
        <P N="clipH" V="WebStiffClipH" D="Horizontal clip width" />
      </O>
    </O>
  </O>
  <O N="Draw Left" T="Group">
    <P N="Guard" V="(WebStiffOrient.EQ.L).OR.(WebStiffOrient.EQ.B)" />
    <P N="CL" V="alignT(Alignment, StartStation+WebStiffLoc[spi-1], Offset)" />
    <P N="GL" V="alignT(Alignment, StartStation+WebStiffLoc[spi-1], Offset-tw/2-WebStiffW/2)" />
    <P N="AdjL" V="CL-GL" />
    <O T="VerticalStiffener" Y="-tw/2" X="WebStiffLoc[spi-1]" Z="AdjL" RZ="PI" AlignH="Warp"
AlignV="Orient">
      <P N="t" V="WebStiffT" D="Thickness" />
      <P N="w" V="WebStiffW" D="Width" />
      <P N="h" V="WebStiffHeight" D="Height" />
      <P N="clipV" V="WebStiffClipV" D="Vertical clip height" />
      <P N="clipH" V="WebStiffClipH" D="Horizontal clip width" />
    </O>
  </O>
</O>
<!-- Draw Connection Stiffeners -->
<O N="Cross Frame Connection Stiffeners" T="Group">
  <P N="Guard" V="ConnStiffOrient.NE.None" />
  <O T="Repeat">
    <P N="S" V="1" />
    <P N="E" V="length(ConnStiffLoc)" />
    <P N="I" V="1" />
    <P N="CTRL" V="spi" T="Text" />

```

```

<P N="spi" V="0" />
<O N="Draw Right" T="Group">
  <P N="Guard" V="(ConnStiffOrient.EQ.R).OR.(ConnStiffOrient.EQ.B)" />
  <P N="CL" V="alignT(Alignment, StartStation+ConnStiffLoc[spi-1], Offset)" />
  <P N="GR" V="alignT(Alignment, StartStation+ConnStiffLoc[spi-1], Offset+tw/2+ConnStiffW/2)" />
  <P N="AdjR" V="CL-GR" />
  <O T="VerticalStiffener" Y="tw/2" X="ConnStiffLoc[spi-1]" Z="AdjR" AlignH="Warp" AlignV="Orient">
    <P N="t" V="ConnStiffT" D="Thickness" />
    <P N="w" V="ConnStiffW" D="Width" />
    <P N="h" V="ConnStiffHeight" D="Height" />
    <P N="clipV" V="ConnStiffClipV" D="Vertical clip height" />
    <P N="clipH" V="ConnStiffClipH" D="Horizontal clip width" />
  </O>
</O>
<O N="Draw Left" T="Group">
  <P N="Guard" V="(ConnStiffOrient.EQ.L).OR.(ConnStiffOrient.EQ.B)" />
  <P N="CL" V="alignT(Alignment, StartStation+ConnStiffLoc[spi-1], Offset)" />
  <P N="GL" V="alignT(Alignment, StartStation+ConnStiffLoc[spi-1], Offset-tw/2-ConnStiffW/2)" />
  <P N="AdjL" V="CL-GL" />
  <O T="VerticalStiffener" Y="-tw/2" X="ConnStiffLoc[spi-1]" RZ="PI" Z="AdjL" AlignH="Warp"
AlignV="Orient">
    <P N="t" V="ConnStiffT" D="Thickness" />
    <P N="w" V="ConnStiffW" D="Width" />
    <P N="h" V="ConnStiffHeight" D="Height" />
    <P N="clipV" V="ConnStiffClipV" D="Vertical clip height" />
    <P N="clipH" V="ConnStiffClipH" D="Horizontal clip width" />
  </O>
</O>
</O>
</O>
<!-- Draw Bearing Stiffeners
-->
<O N="Bearing Stiffeners" T="Group">
  <P N="Guard" V="BearingStiffOrient.NE.None" />
  <O T="Repeat">
    <P N="S" V="1" />
    <P N="E" V="length(BearingStiffLoc)" />
    <P N="I" V="1" />
    <P N="CTRL" V="spi" T="Text" />
    <P N="spi" V="0" />
  <O N="Draw Right" T="Group">
    <P N="Guard" V="(BearingStiffOrient.EQ.R).OR.(BearingStiffOrient.EQ.B)" />
    <P N="CL" V="alignT(Alignment, StartStation+BearingStiffLoc[spi-1], Offset)" />
    <P N="GR" V="alignT(Alignment, StartStation+BearingStiffLoc[spi-1], Offset+tw/2+BearingStiffW/2)" />
    <P N="AdjR" V="CL-GR" />
    <O T="VerticalStiffener" Y="tw/2" X="BearingStiffLoc[0]" Z="AdjR" AlignH="Warp" AlignV="Orient">
      <P N="t" V="BearingStiffT" D="Thickness" />
      <P N="w" V="BearingStiffW" D="Width" />
      <P N="h" V="BearingStiffHeight" D="Height" />
      <P N="clipV" V="BearingStiffClipV" D="Vertical clip height" />
      <P N="clipH" V="BearingStiffClipH" D="Horizontal clip width" />
    </O>
  </O>
</O>
<O N="Draw Left" T="Group">
  <P N="Guard" V="(BearingStiffOrient.EQ.L).OR.(BearingStiffOrient.EQ.B)" />
  <P N="CL" V="alignT(Alignment, StartStation+BearingStiffLoc[spi-1], Offset)" />

```



```

    <P N="GL" V="alignT(Alignment, StartStation+ BearingStiffLoc[spi-1], Offset-tw/2-BearingStiffW/2)" />
    <P N="AdjL" V="CL-GL" />
    <O T="VerticalStiffener" Y="-tw/2" X="BearingStiffLoc[0]" Z="AdjL" RZ="PI" AlignH="Warp"
AlignV="Orient">
    <P N="t" V="BearingStiffT" D="Thickness" />
    <P N="w" V="BearingStiffW" D="Width" />
    <P N="h" V="BearingStiffHeight" D="Height" />
    <P N="clipV" V="BearingStiffClipV" D="Vertical clip height" />
    <P N="clipH" V="BearingStiffClipH" D="Horizontal clip width" />
    </O>
  </O>
</O>
</O>
<!-- Draw Jacking Stiffeners
-->
<O N="Jacking Stiffeners" T="Group">
  <P N="Guard" V="JackingStiffOrient.NE.None" />
  <O T="Repeat">
    <P N="S" V="1" />
    <P N="E" V="length(JackingStiffLoc)" />
    <P N="I" V="1" />
    <P N="CTRL" V="spi" T="Text" />
    <P N="spi" V="0" />
  <O N="Draw Right" T="Group">
    <P N="Guard" V="(JackingStiffOrient.EQ.R).OR.(JackingStiffOrient.EQ.B)" />
    <P N="CL" V="alignT(Alignment, StartStation+JackingStiffLoc[spi-1], Offset)" />
    <P N="GR" V="alignT(Alignment, StartStation+JackingStiffLoc[spi-1], Offset+tw/2+JackingStiffW/2)" />
    <P N="AdjR" V="CL-GR" />
    <O T="VerticalStiffener" Y="tw/2" X="JackingStiffLoc[spi-1]" Z="AdjR" AlignH="Warp" AlignV="Orient">
      <P N="t" V="JackingStiffT" D="Thickness" />
      <P N="w" V="JackingStiffW" D="Width" />
      <P N="h" V="JackingStiffHeight" D="Height" />
      <P N="clipV" V="JackingStiffClipV" D="Vertical clip height" />
      <P N="clipH" V="JackingStiffClipH" D="Horizontal clip width" />
    </O>
  </O>
  <O N="Draw Left" T="Group">
    <P N="Guard" V="(JackingStiffOrient.EQ.L).OR.(JackingStiffOrient.EQ.B)" />
    <P N="CL" V="alignT(Alignment, StartStation+JackingStiffLoc[spi-1], Offset)" />
    <P N="GL" V="alignT(Alignment, StartStation+JackingStiffLoc[spi-1], Offset-tw/2-JackingStiffW/2)" />
    <P N="AdjL" V="CL-GL" />
    <O T="VerticalStiffener" Y="-tw/2" X="JackingStiffLoc[spi-1]" Z="AdjL" RZ="PI" AlignH="Warp"
AlignV="Orient">
      <P N="t" V="JackingStiffT" D="Thickness" />
      <P N="w" V="JackingStiffW" D="Width" />
      <P N="h" V="JackingStiffHeight" D="Height" />
      <P N="clipV" V="JackingStiffClipV" D="Vertical clip height" />
      <P N="clipH" V="JackingStiffClipH" D="Horizontal clip width" />
    </O>
  </O>
</O>
</O>
</O>
</O>

```

### VerticalStiffener

Stiffeners are defined as a Surface object with a thickness. A typical stiffener is rectangular with corner clips at the girder web/flange intersection.

open BrIM VerticalStiffener BY MIKE BARTHOLOMEW

Refresh

Dimensions

W Width	8	h Height	66	t Thickness	0.75
clipV Vertical clip height	2.5	clipH Horizontal clip width	1.5	tw Girder web thickness	0.5

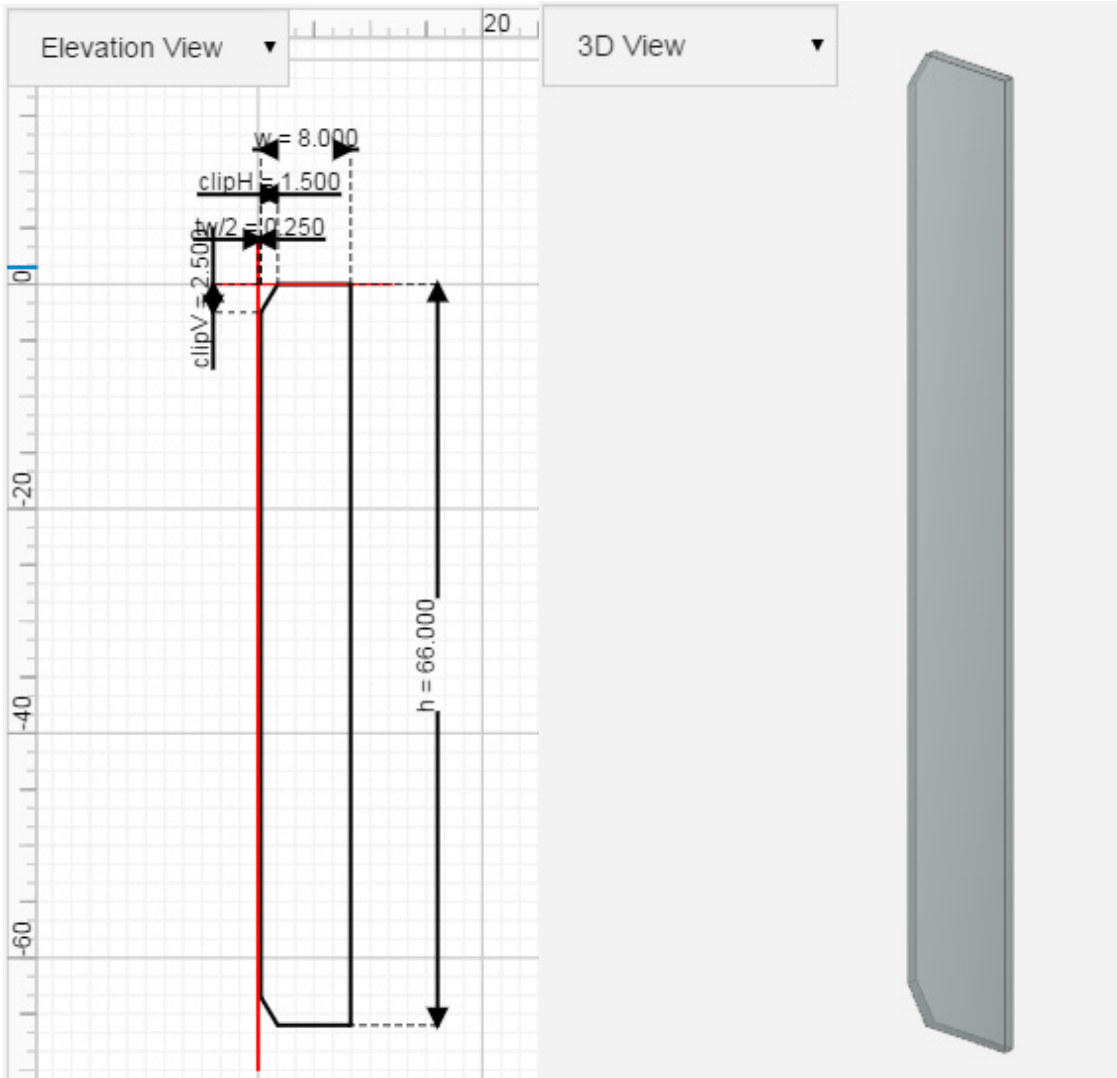

ParamML Code

```

<O N="VerticalStiffener" T="Project">
  <P N="Opacity" V="0.75" />
  <!-- created by Mike Bartholomew on 6/10/2015 -->
  <O N="Dimensions" T="Group">
    <P N="w" V="8" D="Width" Role="Input" Category="Dimensions" />
    <P N="h" V="66" D="Height" Role="Input" Category="Dimensions" />
    <P N="t" V="0.75" D="Thickness" Role="Input" Category="Dimensions" />
    <P N="clipV" V="2.5" D="Vertical clip height" Role="Input" Category="Dimensions" />
    <P N="clipH" V="1.5" D="Horizontal clip width" Role="Input" Category="Dimensions" />
    <P N="tw" V="0.5" D="Girder web thickness" Role="Input" Category="Dimensions" />
  </O>
  <O N="CrossFrameBolts" T="Group">
    <P N="BoltDia" V="0.75" D="Diameter of bolt" Role="Input" Category="CrossFrameBolts" />
    <P N="EdgeDist" V="1.75" D="Distance from edge of Plate to CL of Bolt Hole" Role="Input"
    Category="CrossFrameBolts" />
  </O>
  <O N="TopBoltGroup" T="Group">
    <P N="cols" V="2" D="number of cols" Role="Input" Category="TopBoltGroup" />
    <P N="rows" V="3" D="number of rows" Role="Input" Category="TopBoltGroup" />
    <P N="spaceY" V="3" D="Horiz spacing between columns" Role="Input" Category="TopBoltGroup" />
    <P N="spaceZ" V="3" D="Vert spacing between rows" Role="Input" Category="TopBoltGroup" />
  </O>
  <O N="BotBoltGroup" T="Group">
    <P N="cols" V="2" D="number of cols" Role="Input" Category="BotBoltGroup" />
    <P N="rows" V="5" D="number of rows" Role="Input" Category="BotBoltGroup" />
    <P N="spaceY" V="3" D="Horiz spacing between columns" Role="Input" Category="BotBoltGroup" />
    <P N="spaceZ" V="3" D="Vert spacing between rows" Role="Input" Category="BotBoltGroup" />
  </O>
  <O T="Surface" X="t/2">
    <P N="Thickness" V="t" />
    <O T="Point" Y="clipH" Z="0" />
    <O T="Point" Y="w" Z="0" />
    <O T="Point" Y="w" Z="-h" />
    <O T="Point" Y="clipH" Z="-h" />
    <O T="Point" Y="0" Z="-h+clipV" />
    <O T="Point" Y="0" Z="-clipV" />
  </O>
  <O T="Private">
    <O N="Elevation View" T="CADD">
      <P N="margin" V="w/2" />
      <O T="CADDShape" Y="0" X="tw/2" RZ="0">
        <P N="Color" V="rgb(0, 0, 0)" T="Text" />
        <P N="Thickness" V="2" />
        <P N="IsClosed" V="T" T="Text" />
        <O T="Point" X="clipH" Y="0" />
        <O T="Point" X="w" Y="0" />
        <O T="Point" X="w" Y="-h" />
        <O T="Point" X="clipH" Y="-h" />
        <O T="Point" X="0" Y="-h+clipV" />
        <O T="Point" X="0" Y="-clipV" />
      </O>
      <O N="Working Lines" T="Group">
        <O T="CADDLine" X="0" Y="0" RZ="0">
          <P N="Color" V="#FF0000" T="Text" />
        </O>
      </O>
    </O>
  </O>

```

```

    <P N="Thickness" V="1" />
    <P N="IsClosed" V="F" T="Text" />
    <O T="Point" X="0" Y="margin" />
    <O T="Point" X="0" Y="-h-margin" />
  </O>
  <O T="CADDLine" X="0" Y="0" RZ="0">
    <P N="Color" V="#FF0000" T="Text" />
    <P N="Thickness" V="1" />
    <P N="IsClosed" V="F" T="Text" />
    <O T="Point" X="-margin" Y="0" />
    <O T="Point" X="w+margin" Y="0" />
  </O>
</O>
<O T="CADDDimensionLine" X="tw/2" Y="0" RZ="0">
  <P N="Label" V="w = %d" T="Text" />
  <O T="Point" X="0" Y="0" />
  <O T="Point" X="w" Y="0" />
  <O T="Point" X="0" Y="3*margin" />
</O>
<O T="CADDDimensionLine" Y="0" X="0" RZ="0">
  <P N="Label" V="tw/2 = %d" T="Text" />
  <O T="Point" X="0" Y="0" />
  <O T="Point" X="tw/2" Y="0" />
  <O T="Point" X="0" Y="margin" />
</O>
<O T="CADDDimensionLine" X="0" Y="0" RZ="0">
  <P N="Label" V="h = %d" T="Text" />
  <O T="Point" X="w" Y="-h" />
  <O T="Point" X="w" Y="0" />
  <O T="Point" X="w+2*margin" Y="0" />
</O>
<O T="CADDDimensionLine" X="0" Y="0" RZ="0">
  <P N="Label" V="clipV = %d" T="Text" />
  <O T="Point" X="0" Y="-clipV" />
  <O T="Point" X="0" Y="0" />
  <O T="Point" X="-margin" Y="0" />
</O>
<O T="CADDDimensionLine" X="tw/2" Y="0" RZ="0">
  <P N="Label" V="clipH = %d" T="Text" />
  <O T="Point" X="0" Y="0" />
  <O T="Point" X="clipH" Y="0" />
  <O T="Point" X="0" Y="2*margin" />
</O>
</O>
</O>
</O>

```

### **BoltedFieldSplice (BB)**

The BoltedFieldSplice (BB) joins two girders with different plate thicknesses. The object is comprised of multiple connection plates which are constructed as Surface objects with a thickness. All plates include holes for bolts. To account for the variation in web and flange thickness between girders, additional fill plates are included on the thinner side of the connection. The BoltedFieldSplice (BB) object references other objects, including SplicePlate, Bolt (BB), and BoltGroup (BB).

**open BrIM BoltedFieldSplice (BB)** BY BENJAMIN BLASEN

Refresh Splice Geometry ▾

gap gap between girders $\frac{1}{4} = 0.25$	sp_sta x-Station of splices 0	flange_thickness plate thickness of the flange connection 0.75
web_thickness plate thickness of the web connection 0.375		

**open BrIM BoltedFieldSplice (BB)** BY BENJAMIN BLASEN

Refresh Web Bolt Pattern ▾

WNUMX the number of bolt columns in longitudinal axis per side 2	WSPCX the spacing at center in longitudinal axis 5.5	WSPX the spacing between bolts in longitudinal axis 3
WedX the edge clearance in longitudinal axis 1.75	WNUMY the number of bolt rows in vertical axis 20	WSPY the spacing between bolts along vertical axis 3
wedy the edge clearance in vertical axis 1.75		

**open BrIM BoltedFieldSplice (BB)** BY BENJAMIN BLASEN

Refresh Flange Bolt Pattern ▾

fnumX the number of equally spaced bolts in longitudinal axis 3	fspCX the spacing at center in longitudinal axis 4.5	fspX the spacing between bolts in longitudinal axis 4.25
fedX the edge clearance in longitudinal axis 1.75	fnumY the number of equally spaced bolts in transverse axis 2	fspY the spacing between bolts along transverse axis 4.25
fedy the edge clearance in transverse axis 1.75	fspCY the spacing at center in longitudinal axis 6	

**open BrIM** BoltedFieldSplice (BB) BY BENJAMIN BLASEN

Refresh

Bolts ▾

<b>dS</b> Diameter of the shaft of the bolt.	<b>dh</b> Diameter of the head of the bolt.	<b>dN</b> Diameter of the nut of the bolt.
0.75	1.4375	1.4375
<b>th</b> Thickness of the head.	<b>tn</b> Thickness of the nut.	
$\frac{15}{32} = 0.4688$	$\frac{47}{64} = 0.7344$	

**open BrIM** BoltedFieldSplice (BB) BY BENJAMIN BLASEN

Refresh

Girder Data ▾

<b>dWA</b> Web depth of the A girder	<b>tWA</b> Web thickness of the A girder	<b>bftA</b> Width of the top flange of the A girder
66	$\frac{11}{16} = 0.6875$	18
<b>tftA</b> Thickness of the top flange of the A girder	<b>bfbA</b> Width of the bottom flange of the A girder	<b>tfbA</b> Thickness of the bottom flange of the A girder
0.875	20	1
<b>dWB</b> Web depth of the B girder	<b>tWB</b> Web thickness of the B girder	<b>bftB</b> Width of the top flange of the B girder
66	$\frac{15}{16} = 0.9375$	20
<b>tftB</b> Thickness of the top flange of the B girder	<b>bfbB</b> Width of the bottom flange of the B girder	<b>tfbB</b> Thickness of the bottom flange of the B girder
1.125	20	1.5

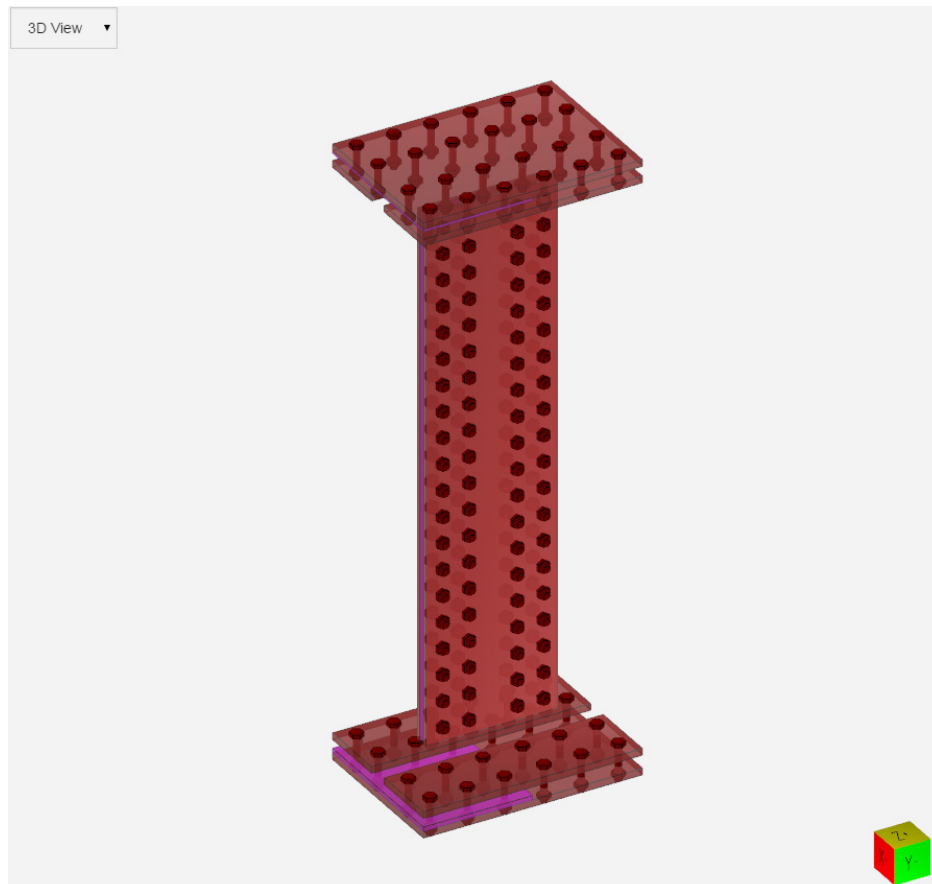

ParamML Code

```

<O N="BoltedFieldSplice (BB)" T="Project">
  <O N="ObjDesc" T="Group">
    <!--
  <p> | BoltedFieldSplice (BB) | object represents a bolted splice connection between steel girders.
  </p>
  <br> Created by <i>Ali Koc</i> on 5/29/2015 </br>
  <br> Updated by <i>Mike Bartholomew</i> on 6/28/2015 </br>
  <br> Updated by <i>Benjamin Blasen</i> on 12/18/2015 </br>

-->
</O>
<O N="userinput" T="Group">
  <P N="gap" V="1/4" D="gap between girders" Role="Input" Category="Splice Geometry" />
  <P N="sp_sta" V="0" D="x-Station of splices" Role="Input" Category="Splice Geometry" />
  <P N="flange_thickness" V="0.75" D="plate thickness of the flange connection" Role="Input" Category="Splice
Geometry" />
  <P N="web_thickness" V="0.375" D="plate thickness of the web connection" Role="Input" Category="Splice
Geometry" />
  <P N="ds" V="0.75" D="Diameter of the shaft of the bolt." Role="Input" Category="Bolts" />
  <P N="dh" V="1.4375" D="Diameter of the head of the bolt." Role="Input" Category="Bolts" />
  <P N="dn" V="1.4375" D="Diameter of the nut of the bolt." Role="Input" Category="Bolts" />
  <P N="th" V="15/32" D="Thickness of the head." Role="Input" Category="Bolts" />
  <P N="tn" V="47/64" D="Thickness of the nut." Role="Input" Category="Bolts" />
  <P N="wnumx" V="2" D="the number of bolt columns in longitudinal axis per side" Role="Input"
Category="Web Bolt Pattern" />
  <P N="wspcx" V="5.5" D="the spacing at center in longitudinal axis" Role="Input" Category="Web Bolt Pattern"
/>
  <P N="wspx" V="3" D="the spacing between bolts in longitudinal axis" Role="Input" Category="Web Bolt
Pattern" />
  <P N="wedx" V="1.75" D="the edge clearance in longitudinal axis" Role="Input" Category="Web Bolt Pattern"
/>
  <P N="wnumy" V="20" D="the number of bolt rows in vertical axis" Role="Input" Category="Web Bolt Pattern"
/>
  <P N="wspy" V="3" D="the spacing between bolts along vertical axis" Role="Input" Category="Web Bolt
Pattern" />
  <P N="wedy" V="1.75" D="the edge clearance in vertical axis" Role="Input" Category="Web Bolt Pattern" />
  <P N="fnumx" V="3" D="the number of equally spaced bolts in longitudinal axis" Role="Input"
Category="Flange Bolt Pattern" />
  <P N="fspcx" V="4.5" D="the spacing at center in longitudinal axis" Role="Input" Category="Flange Bolt
Pattern" />
  <P N="fspx" V="4.25" D="the spacing between bolts in longitudinal axis" Role="Input" Category="Flange Bolt
Pattern" />
  <P N="fedx" V="1.75" D="the edge clearance in longitudinal axis" Role="Input" Category="Flange Bolt Pattern"
/>
  <P N="fnumy" V="2" D="the number of equally spaced bolts in transverse axis" Role="Input" Category="Flange
Bolt Pattern" />
  <P N="fspy" V="4.25" D="the spacing between bolts along transverse axis" Role="Input" Category="Flange Bolt
Pattern" />
  <P N="fedy" V="1.75" D="the edge clearance in transverse axis" Role="Input" Category="Flange Bolt Pattern"
/>
  <P N="fspcy" V="6" D="the spacing at center in longitudinal axis" Role="Input" Category="Flange Bolt Pattern"
/>
  <P N="dwa" V="66" D="Web depth of the A girder" Role="Input" Category="Girder Data" />
  <P N="twa" V="11/16" D="Web thickness of the A girder" Role="Input" Category="Girder Data" />

```

```

<P N="bftA" V="18" D="Width of the top flange of the A girder" Role="Input" Category="Girder Data" />
<P N="tftA" V="0.875" D="Thickness of the top flange of the A girder" Role="Input" Category="Girder Data" />
<P N="bfbA" V="20" D="Width of the bottom flange of the A girder" Role="Input" Category="Girder Data" />
<P N="tftA" V="1.0" D="Thickness of the bottom flange of the A girder" Role="Input" Category="Girder Data"
/>
<P N="dwB" V="66" D="Web depth of the B girder" Role="Input" Category="Girder Data" />
<P N="twB" V="15/16" D="Web thickness of the B girder" Role="Input" Category="Girder Data" />
<P N="bftB" V="20" D="Width of the top flange of the B girder" Role="Input" Category="Girder Data" />
<P N="tftB" V="1.125" D="Thickness of the top flange of the B girder" Role="Input" Category="Girder Data" />
<P N="bfbB" V="20" D="Width of the bottom flange of the B girder" Role="Input" Category="Girder Data" />
<P N="tftB" V="1.5" D="Thickness of the bottom flange of the B girder" Role="Input" Category="Girder Data"
/>
</O>
<O N="bolt75" T="Group">
  <P N="bolt_ds" V="ds" />
  <P N="bolt_dh" V="dh" />
  <P N="bolt_dn" V="dn" />
  <P N="bolt_th" V="th" />
  <P N="bolt_tn" V="tn" />
</O>
<O N="BoltedFieldSplice" T="Group" X="sp_sta+gap/4">
  <P N="g_gap" V="gap" D="gap between girders" />
  <P N="Opacity" V="0.8" />
  <O N="WebConnection" T="Group" X="-plate_length/2">
    <P N="Color" V="#ca2e2e" T="Text" />
    <P N="plate_thickness" V="web_thickness" />
    <P N="numx" V="wnumx" />
    <P N="spcx" V="wspcx" />
    <P N="spx" V="wspx" />
    <P N="edx" V="wedx" />
    <P N="numy" V="wnumy" />
    <P N="spy" V="wspx" />
    <P N="edy" V="wedy" />
    <P N="tw_max" V="max(twA, twB)" D="larger web thickness" />
    <P N="tw_min" V="min(twA, twB)" D="smaller web thickness" />
    <P N="plate_length" V="edx * 2 + (spx * (numx - 1)) * 2 + spcx" />
    <P N="plate_width" V="edy * 2 + (spy * (numy - 1))" />
    <O N="WebPlates" T="Group">
      <O N="WebPanelA" T="SplicePlate2" X="plate_length/2" Y="-tw_max/2" Z="-dwA*0.5" RX="PI/2"
RY="PI/2">
        <P N="Color" V="#ca2e2e" T="Text" />
        <P N="w" V="plate_width" D="width of the plate" />
        <P N="h" V="plate_length" D="height of the plate" />
        <P N="t" V="plate_thickness" D="thickness of the plate" />
        <P N="nrows" V="numx" D="number of horizontal rows" />
        <P N="ncols" V="numy" D="number of vertical columns" />
        <P N="spY" V="spy" D="vector of horizontal spacing between bolt holes" />
        <P N="spZ" V="spx" D="vector of vertical spacing between bolt holes" />
        <P N="d" V="ds" D="bolt diameter" />
        <P N="c" V="edy" D="clearance from edge" />
      </O>
      <O N="WebPanelB" T="SplicePlate2" X="plate_length/2" Y="tw_max/2+plate_thickness" Z="-dwB*0.5"
RX="PI/2" RY="PI/2">
        <P N="Color" V="#ca2e2e" T="Text" />
        <P N="w" V="plate_width" D="width of the plate" />
        <P N="h" V="plate_length" D="height of the plate" />
      </O>
    </O>
  </O>

```



```

<P N="t" V="plate_thickness" D="thickness of the plate" />
<P N="nrows" V="numx" D="number of horizontal rows" />
<P N="ncols" V="numy" D="number of vertical columns" />
<P N="spY" V="spy" D="vector of horizontal spacing between bolt holes" />
<P N="spZ" V="spx" D="vector of vertical spacing between bolt holes" />
<P N="d" V="ds" D="bolt diameter" />
<P N="c" V="edy" D="clearance from edge" />
</O>
<O N="WebFillPlateA" T="SplicePlate2" Y="-tw_min/2" X="iif(twA .GT. twB, 3*plate_length/4+g_gap/4,
plate_length/4-g_gap/4)" Z="-dwA*0.5" RY="Pi/2" RX="Pi/2">
  <P N="Guard" V="tw_max .NE. tw_min" />
  <P N="Color" V="#da12d8" T="Text" />
  <P N="w" V="plate_width" D="width of the plate" />
  <P N="h" V="(plate_length - g_gap) / 2" D="height of the plate" />
  <P N="t" V="(tw_max-tw_min)/2" D="thickness of the plate" />
  <P N="nrows" V="numx" D="number of horizontal rows" />
  <P N="ncols" V="numy" D="number of vertical columns" />
  <P N="spY" V="spy" D="vector of horizontal spacing between bolt holes" />
  <P N="spZ" V="spx" D="vector of vertical spacing between bolt holes" />
  <P N="d" V="ds" D="bolt diameter" />
  <P N="c" V="edy" D="clearance from edge" />
</O>
<O N="WebFillPlateB" T="SplicePlate2" Y="tw_max/2" X="iif(twA .GT. twB, 3*plate_length/4+g_gap/4,
plate_length/4-g_gap/4)" Z="-dwB*0.5" RY="Pi/2" RX="Pi/2">
  <P N="Guard" V="tw_max .NE. tw_min" />
  <P N="Color" V="#da12d8" T="Text" />
  <P N="w" V="plate_width" D="width of the plate" />
  <P N="h" V="(plate_length - g_gap) / 2" D="height of the plate" />
  <P N="t" V="(tw_max-tw_min)/2" D="thickness of the plate" />
  <P N="nrows" V="numx" D="number of horizontal rows" />
  <P N="ncols" V="numy" D="number of vertical columns" />
  <P N="spY" V="spy" D="vector of horizontal spacing between bolt holes" />
  <P N="spZ" V="spx" D="vector of vertical spacing between bolt holes" />
  <P N="d" V="ds" D="bolt diameter" />
  <P N="c" V="edy" D="clearance from edge" />
</O>
</O>
<!-->
<O N="WebBolts" T="Group">
  <O N="WebBoltsA" T="BoltGroup (BB)" Extends="bolt75" Y="tw_max/2+plate_thickness" X="edx" Z="-
dwA*0.5+plate_width/2-edy" RX="Pi/2">
    <P N="Color" V="#ca2e2e" T="Text" />
    <P N="rows" V="numy" D="number of rows in this bolt group." />
    <P N="cols" V="numx" D="number of columns in this bolt group." />
    <P N="col_spacing" V="spx" D="the spacing between columns" />
    <P N="row_spacing" V="spy" D="the spacing between columns" />
    <P N="thickness" V="tw_max + 2 * plate_thickness" />
  </O>
  <O N="WebBoltsB" T="BoltGroup (BB)" Extends="WebBoltsA" X="plate_length/2+spcx/2" Z="-
dwB*0.5+plate_width/2-edy" />
  </O>
</O>
<O N="Flange Field Splice" T="Group">
  <P N="tft_max" V="max(tftA, tftB)" D="larger top flange thickness" />
  <P N="tft_min" V="min(tftA, tftB)" D="smaller top flange thickness" />
  <P N="tfb_max" V="max(tfbA, tfbB)" D="larger bottom flange thickness" />

```

```

<P N="tfb_min" V="min(tfbA, tfbB)" D="smaller bottom flange thickness" />
<P N="d_max" V="max(dwA + tfbA, dwB + tfbB)" D="larger web depth + bottom flange thickness" />
<P N="d_min" V="min(dwA + tfbA, dwB + tfbB)" D="smaller web depth + bottom flange thickness" />
<P N="dw_max" V="max(dwA, dwB)" D="smaller web depth" />
<P N="dw_min" V="min(dwA, dwB)" D="smaller web depth" />
<P N="w_o" V="min(bftA, bftB)" D="outside plate's width" />
<P N="w_i" V="min((bftA-twA)/2, (bftB-twB)/2)" D="inside plate's width" />
<P N="plate_thickness" V="flange_thickness" />
<P N="numx" V="fnumx" />
<P N="spcx" V="fspcx" />
<P N="spx" V="fspx" />
<P N="edx" V="fedx" />
<P N="numy" V="fnumy" />
<P N="spy" V="fspy" />
<P N="edy" V="fedy" />
<P N="spcy" V="fspcy" />
<P N="length" V="edx * 2 + (spx * (numx - 1)) * 2 + spcx" D="length of the plate" />
<P N="width" V="edy * 2 + (spy * (numy - 1)) * 2 + spcy" D="width of the outer plate along tranverse axis" />
<P N="width_inside" V="edy * 2 + spy * (numy - 1)" D="width of each inner plate along transverse axis" />
<O N="TopFlangePlates" T="Group">
  <O N="PanelOutside" T="SplicePlate2" X="0" Z="tft_max+plate_thickness" RY="PI/2">
    <P N="Color" V="#991111" T="Text" />
    <P N="w" V="width" D="width of the plate" />
    <P N="h" V="length" D="height of the plate" />
    <P N="t" V="plate_thickness" D="thickness of the plate" />
    <P N="nrows" V="2*numx" D="number of horizontal rows" />
    <P N="ncols" V="numy" D="number of vertical columns" />
    <P N="spY" V="spx" D="vector of horizontal spacing between bolt holes" />
    <P N="spZ" V="spy" D="vector of vertical spacing between bolt holes" />
    <P N="d" V="ds" D="bolt diameter" />
    <P N="c" V="edy" D="clearance from edge" />
  </O>
  <O N="PanelInsideA" T="SplicePlate2" Y="(width - width_inside) / 2" X="0" Z="0" RY="PI/2">
    <P N="Color" V="#991111" T="Text" />
    <P N="w" V="width_inside" D="width of the plate" />
    <P N="h" V="length" D="height of the plate" />
    <P N="t" V="plate_thickness" D="thickness of the plate" />
    <P N="nrows" V="2*numx" D="number of horizontal rows" />
    <P N="ncols" V="numy" D="number of vertical columns" />
    <P N="spY" V="spx" D="vector of horizontal spacing between bolt holes" />
    <P N="spZ" V="spy" D="vector of vertical spacing between bolt holes" />
    <P N="d" V="ds" D="bolt diameter" />
    <P N="c" V="edy" D="clearance from edge" />
  </O>
  <O N="PanelInsideB" T="SplicePlate2" Y="-(width - width_inside) / 2" X="0" Z="0" RY="PI/2">
    <P N="Color" V="#991111" T="Text" />
    <P N="w" V="width_inside" D="width of the plate" />
    <P N="h" V="length" D="height of the plate" />
    <P N="t" V="plate_thickness" D="thickness of the plate" />
    <P N="nrows" V="2*numx" D="number of horizontal rows" />
    <P N="ncols" V="numy" D="number of vertical columns" />
    <P N="spY" V="spx" D="vector of horizontal spacing between bolt holes" />
    <P N="spZ" V="spy" D="vector of vertical spacing between bolt holes" />
    <P N="d" V="ds" D="bolt diameter" />
    <P N="c" V="edy" D="clearance from edge" />
  </O>

```

```

<O N="PanelFill" T="SplicePlate2" X="iif(tftA.GT.tftB,length/4+g_gap/8,-length/4-g_gap/8)" Z="tft_max"
RY="PI/2">
  <P N="Guard" V="tft_min.NE.tft_max" />
  <P N="Color" V="#da12d8" T="Text" />
  <P N="w" V="width" D="width of the plate" />
  <P N="h" V="length/2-g_gap/4" D="height of the plate" />
  <P N="t" V="tft_max-tft_min" D="thickness of the plate" />
  <P N="nrows" V="numx" D="number of horizontal rows" />
  <P N="ncols" V="2*numy" D="number of vertical columns" />
  <P N="spY" V="spx" D="vector of horizontal spacing between bolt holes" />
  <P N="spZ" V="spy" D="vector of vertical spacing between bolt holes" />
  <P N="d" V="ds" D="bolt diameter" />
  <P N="c" V="edy" D="clearance from edge" />
</O>
</O>
<!-->
<O N="TopFlangeBolts" T="Group">
  <O N="TopFlangeBoltsAL" T="BoltGroup (BB)" Extends="bolt75" Y="spcy/2" X="-length/2+edx"
Z="tft_max+plate_thickness">
    <P N="Color" V="#ca2e2e" T="Text" />
    <P N="rows" V="numy" D="number of rows in this bolt group." />
    <P N="cols" V="numx" D="number of columns in this bolt group." />
    <P N="col_spacing" V="spx" D="the spacing between columns" />
    <P N="row_spacing" V="spy" D="the spacing between columns" />
    <P N="thickness" V="tft_max + 2 * plate_thickness" />
  </O>
  <O N="TopFlangeBoltsAR" T="BoltGroup" Extends="TopFlangeBoltsAL" Y="-spcy/2-(rows-1)*row_spacing"
/>
  <O N="TopFlangeBoltsBL" T="BoltGroup" Extends="TopFlangeBoltsAL" X="spx/2" />
  <O N="TopFlangeBoltsBR" T="BoltGroup" Extends="TopFlangeBoltsAR" X="spx/2" />
</O>
<O N="BottomFlangePlates" T="Group">
  <O N="PanelOutside" T="SplicePlate2" X="0" Z="-d_max" RY="PI/2">
    <P N="Color" V="#991111" T="Text" />
    <P N="w" V="width" D="width of the plate" />
    <P N="h" V="length" D="height of the plate" />
    <P N="t" V="plate_thickness" D="thickness of the plate" />
    <P N="nrows" V="2*numx" D="number of horizontal rows" />
    <P N="ncols" V="numy" D="number of vertical columns" />
    <P N="spY" V="spx" D="vector of horizontal spacing between bolt holes" />
    <P N="spZ" V="spy" D="vector of vertical spacing between bolt holes" />
    <P N="d" V="ds" D="bolt diameter" />
    <P N="c" V="edy" D="clearance from edge" />
  </O>
  <O N="PanelInsideA" T="SplicePlate2" Y="(width - width_inside) / 2" X="0" Z="-dw_min+plate_thickness"
RY="PI/2">
    <P N="Color" V="#991111" T="Text" />
    <P N="w" V="width_inside" D="width of the plate" />
    <P N="h" V="length" D="height of the plate" />
    <P N="t" V="plate_thickness" D="thickness of the plate" />
    <P N="nrows" V="2*numx" D="number of horizontal rows" />
    <P N="ncols" V="numy" D="number of vertical columns" />
    <P N="spY" V="spx" D="vector of horizontal spacing between bolt holes" />
    <P N="spZ" V="spy" D="vector of vertical spacing between bolt holes" />
    <P N="d" V="ds" D="bolt diameter" />
    <P N="c" V="edy" D="clearance from edge" />
  </O>

```

```

</O>
<O N="PanelInsideB" T="SplicePlate2" Y="-(width - width_inside) / 2" X="0" Z="-dw_min+plate_thickness"
RY="PI/2">
  <P N="Color" V="#991111" T="Text" />
  <P N="w" V="width_inside" D="width of the plate" />
  <P N="h" V="length" D="height of the plate" />
  <P N="t" V="plate_thickness" D="thickness of the plate" />
  <P N="nrows" V="2*numx" D="number of horizontal rows" />
  <P N="ncols" V="numy" D="number of vertical columns" />
  <P N="spY" V="spx" D="vector of horizontal spacing between bolt holes" />
  <P N="spZ" V="spy" D="vector of vertical spacing between bolt holes" />
  <P N="d" V="ds" D="bolt diameter" />
  <P N="c" V="edy" D="clearance from edge" />
</O>
<O N="PanelFillOuter" T="SplicePlate2" X="iif(tfbA .GT. tfbB, length/4+g_gap/8, -length/4-g_gap/8)" Z="-
dw_min-tfb_max+(d_max-d_min)" RX="PI/2" RZ="PI/2" RY="PI/2">
  <P N="Guard" V="tfb_min .NE. tfb_max" />
  <P N="Color" V="#da12d8" T="Text" />
  <P N="w" V="width" D="width of the plate" />
  <P N="h" V="length/2-g_gap/4" D="height of the plate" />
  <P N="t" V="d_max-d_min" D="thickness of the plate" />
  <P N="nrows" V="numx" D="number of horizontal rows" />
  <P N="ncols" V="numy" D="number of vertical columns" />
  <P N="spY" V="spx" D="vector of horizontal spacing between bolt holes" />
  <P N="spZ" V="spy" D="vector of vertical spacing between bolt holes" />
  <P N="d" V="ds" D="bolt diameter" />
  <P N="c" V="edy" D="clearance from edge" />
</O>
</O>
<!-->
<O N="BottomFlangeBolts" T="Group">
  <O N="BottomFlangeWebBoltsAL" T="BoltGroup (BB)" Extends="bolt75" Y="spcy/2" X="-length/2+edx"
Z="-dw_min+plate_thickness">
    <P N="Color" V="#ca2e2e" T="Text" />
    <P N="rows" V="numy" D="number of rows in this bolt group." />
    <P N="cols" V="numx" D="number of columns in this bolt group." />
    <P N="col_spacing" V="spx" D="the spacing between columns" />
    <P N="row_spacing" V="spy" D="the spacing between columns" />
    <P N="thickness" V="(d_max-dw_min) + 2 * plate_thickness" />
  </O>
  <O N="BottomFlangeWebBoltsAR" T="BoltGroup" Extends="BottomFlangeWebBoltsAL" Y="-spcy/2-(rows-
1)*row_spacing" />
  <O N="BottomFlangeWebBoltsBL" T="BoltGroup" Extends="BottomFlangeWebBoltsAL" X="spx/2" />
  <O N="BottomFlangeWebBoltsBR" T="BoltGroup" Extends="BottomFlangeWebBoltsAR" X="spx/2" />
</O>
</O>
</O>
</O>

```

## SplicePlate

SplicePlate object is used connection of steel members. This object allows for variable bolt spacing in both the horizontal and vertical direction. Examples of library objects that use this splice include Diaphragms.



**SplicePlate** BY BENJAMIN BLASEN

Plate Dimensions ▾

Refresh

W width of the plate  

15

nROWS number of horizontal rows  

6

spZ vertical spacing between bolt holes  

[2, 3, 4]

h height of the plate  

15

nCOLS number of vertical columns  

4

d bolt diameter  

0.75

t thickness of the plate  

0.5

spY horizontal spacing between bolt holes  

[3, 6]

C clearance from edge  

1.75

3D View ▾

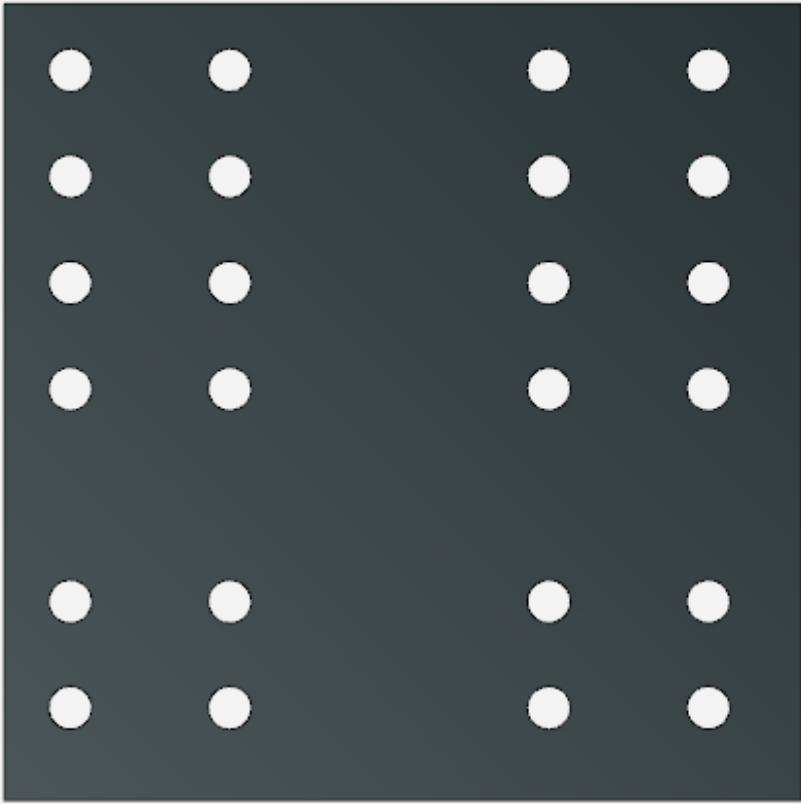



ParamML Code

```
<O N="SplicePlate" T="Project">
```

```
  <O N="ObjDesc" T="Group">
```

```
    <!--
```

```
<p> |SplicePlate| object is used connection of steel members. This object allows for variable bolt spacing in both the horizontal and vertical direction. Examples of library objects that use this splice include Diaphragms.
```

```
</p>
```

```
<br> Created by <i>Ali Koc</i> on 4/5/2015 </br>
```

```
<br> Updated by <i>Mike Bartholomew</i> on 7/9/2015 </br>
```

```
<br> Updated by <i>Benjamin Blasen</i> on 7/9/2015 </br>
```

```
-->
```

```
</O>
```

```
<O N="Plate Dimensions" T="Group">
```

```
  <P N="w" V="15" D="width of the plate" Role="Input" Category="Plate Dimensions" />
```

```
  <P N="h" V="15" D="height of the plate" Role="Input" Category="Plate Dimensions" />
```

```
  <P N="t" V="0.5" D="thickness of the plate" Role="Input" Category="Plate Dimensions" />
```

```
  <P N="nrows" V="6" D="number of horizontal rows" Role="Input" Category="Plate Dimensions" />
```

```
  <P N="ncols" V="4" D="number of vertical columns" Role="Input" Category="Plate Dimensions" />
```

```
  <P N="spY" V="[3,6]" D="horizontal spacing between bolt holes" Role="Input" Category="Plate Dimensions" />
```

```
  <P N="spZ" V="[2,3,4]" D="vertical spacing between bolt holes " Role="Input" Category="Plate Dimensions" />
```

```
  <P N="d" V="0.75" D="bolt diameter" Role="Input" Category="Plate Dimensions" />
```

```
  <P N="c" V="1.75" D="clearance from edge" Role="Input" Category="Plate Dimensions" />
```

```
</O>
```

```
<O N="Plate" T="Group">
```

```
  <O T="Surface">
```

```
    <P N="Thickness" V="t" />
```

```
    <P N="r" V="(d+1/16)/2" D="radius of bolt hole" />
```

```
    <O T="Point" Y="w/2" Z="-h/2" />
```

```
    <O T="Point" Y="-w/2" Z="-h/2" />
```

```
    <O T="Point" Y="-w/2" Z="h/2" />
```

```
    <O T="Point" Y="w/2" Z="h/2" />
```

```
    <O T="Repeat" S="0" I="1" E="nrows-1" CTRL="j" j="1">
```

```
      <O T="Repeat" S="0" I="1" E="ncols-1" CTRL="i" i="1">
```

```
        <P N="locY" V="iif(spY[i-1] .GT. 0,-w/2 + c + spY[i-1] * i,-w/2 + c + spY[0] * i)" D="Y location of the bolt hole" />
```

```
        <P N="locZ" V="iif(spZ[j-1] .GT. 0,-h/2 + c + spZ[j-1] * j,-h/2 + c + spZ[0] * j)" D="Z location of the bolt hole" />
```

```
      <O T="Circle" Y="locY" Z="locZ" RY="PI/2">
```

```
        <P N="IsCutout" V="1" />
```

```
        <P N="Radius" V="r" />
```

```
        <P N="Segments" V="20" />
```

```
      </O>
```

```
    </O>
```

```
  </O>
```

```
</O>
```

```
</O>
```

```
</O>
```

**Bolt (BB)**

The Bolt (BB) object represents a bolt clamping other objects between two points in space. This allows the object to be drawn at any orientation between the two points. The hex head of the bolt and the nut are each extruded Circle objects with 6 segments between two points representing the head and nut thicknesses, while the shank of the bolt is an extruded Circle with a refinement of 20 segments. Besides the two points, the diameter of the shaft of the bolt, the diameter of the circumscribed circle that forms the hex heads, and the thickness of bolt head and nut are required input.

open  
BrIM Bolt (BB) BY BENJAMIN BLASEN

Refresh

Params ▾

X_1 X location of the first point.	Y_1 Y location of the first point.	Z_1 Z location of the first point.
0	0	0
X_2 X location of the second point.	Y_2 Y location of the second point.	Z_2 Z location of the second point.
0	0	-2
d_s Diameter of the shaft of the bolt.	d_h Diameter of the head of the bolt.	d_n Diameter of the nut of the bolt.
0.75	1.4375	1.4375
t_h Thickness of the head.	t_n Thickness of the nut.	
$\frac{15}{32} = 0.4688$	$\frac{47}{64} = 0.7344$	

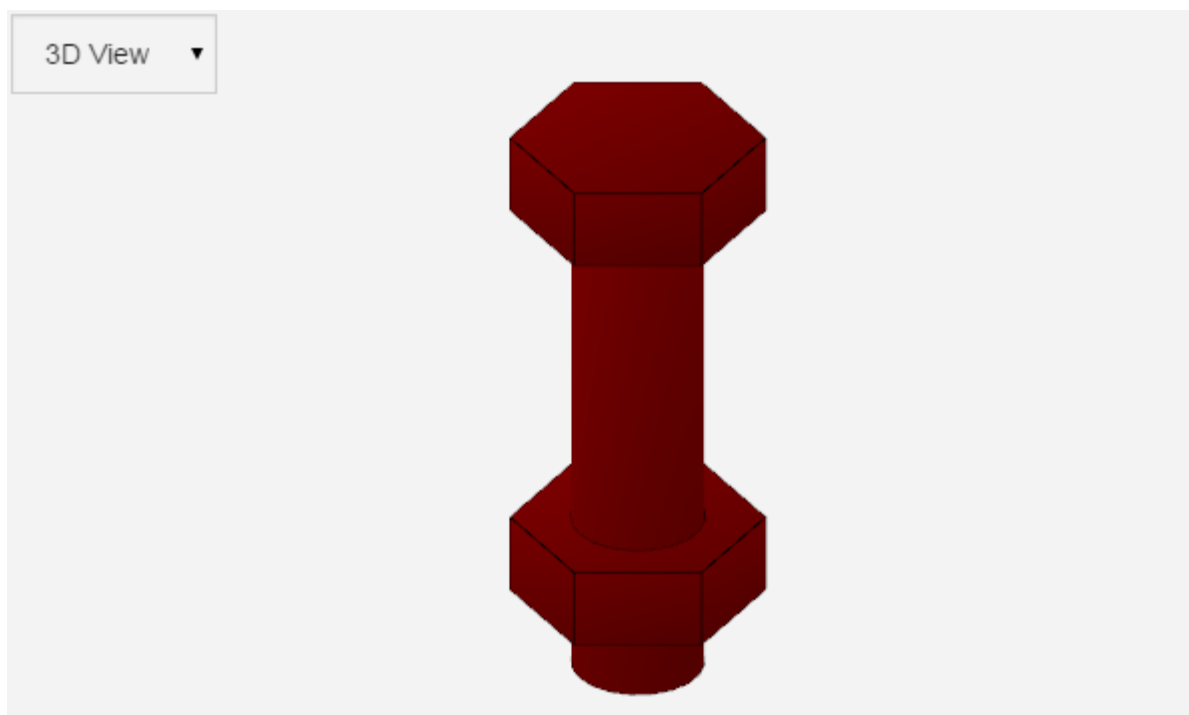

ParamML Code

```

<O N="Bolt (BB)" T="Project">
  <P N="ObjLabel" V="Bolt" T="Text" />
  <P N="X_1" V="0" D="X location of the first point." Role="Input" UT="Length" UC="Properties" />
  <P N="Y_1" V="0" D="Y location of the first point." Role="Input" UT="Length" UC="Properties" />
  <P N="Z_1" V="0" D="Z location of the first point." Role="Input" UT="Length" UC="Properties" />
  <P N="X_2" V="0" D="X location of the second point." Role="Input" UT="Length" UC="Properties" />
  <P N="Y_2" V="0" D="Y location of the second point." Role="Input" UT="Length" UC="Properties" />
  <P N="Z_2" V="-2" D="Z location of the second point." Role="Input" UT="Length" UC="Properties" />
  <P N="d_s" V="0.75" D="Diameter of the shaft of the bolt." Role="Input" UT="Length" UC="Properties" />
  <P N="d_h" V="1.4375" D="Diameter of the head of the bolt." Role="Input" UT="Length" UC="Properties" />
  <P N="d_n" V="1.4375" D="Diameter of the nut of the bolt." Role="Input" UT="Length" UC="Properties" />
  <P N="t_h" V="15/32" D="Thickness of the head." Role="Input" UT="Length" UC="Properties" />
  <P N="t_n" V="47/64" D="Thickness of the nut." Role="Input" UT="Length" UC="Properties" />
  <P N="Length" V="sqrt(pow(X_2 - X_1, 2) + pow(Y_2 - Y_1, 2) + pow(Z_2 - Z_1, 2))" D="Clear distance between
the head and the nut of the bolt." />
  <P N="X_th" V="(X_2 - X_1) * (-t_h / Length) + X_1" D="X location of the top of the head." />
  <P N="Y_th" V="(Y_2 - Y_1) * (-t_h / Length) + Y_1" D="Y location of the top of the head." />
  <P N="Z_th" V="(Z_2 - Z_1) * (-t_h / Length) + Z_1" D="Z location of the top of the head." />
  <P N="X_on" V="(X_2 - X_1) * (1 + t_h / Length) + X_1" D="X location of the outer face of the nut." />
  <P N="Y_on" V="(Y_2 - Y_1) * (1 + t_h / Length) + Y_1" D="Y location of the outer face of the nut." />
  <P N="Z_on" V="(Z_2 - Z_1) * (1 + t_h / Length) + Z_1" D="Z location of the outer face of the nut." />
  <P N="X_os" V="(X_2 - X_1) * (1 + (t_h * 2) / Length) + X_1" D="X location of the outer face of the shaft." />
  <P N="Y_os" V="(Y_2 - Y_1) * (1 + (t_h * 2) / Length) + Y_1" D="Y location of the outer face of the shaft." />
  <P N="Z_os" V="(Z_2 - Z_1) * (1 + (t_h * 2) / Length) + Z_1" D="Z location of the outer face of the shaft." />
  <P N="Refinement" V="20" D="Number of segments used to draw the shaft of the bolt." />
</O N="ObjDesc" T="Group">
  <!--
<p> |Bolt (BB)| object represents a bolt that clamps objects between
  specified two points P1 (X_1,Y_1,Z_1) and P2 (X_2,Y_2,Z_2) in
  3D space. This allows us to use this object to draw a bolt at any
  orientation between the two points.
</p>
<br> Created by <i>Ali Koc</i> on 5/29/2015 </br>
<br> Updated by <i>Benjamin Blasen</i> on 12/18/2015 </br>

```

```

-->
</O>
<O N="BoltHexHead" T="Volume">
  <P N="Color" V="#b60000" T="Text" />
  <O T="Point" Y="Y_th" X="X_th" Z="Z_th" />
  <O T="Point" Y="Y_1" X="X_1" Z="Z_1" />
  <O T="Section">
    <O T="Circle">
      <P N="Segments" V="6" />
      <P N="Radius" V="d_h/2" />
    </O>
  </O>
</O>
<O N="BoltShaft" T="Volume">
  <P N="Color" V="#b60000" T="Text" />
  <P N="DrawBorder" V="0" />
  <P N="DrawFaceA" V="0" />
  <P N="DrawFaceABorder" V="1" />
  <O T="Point" Y="Y_1" X="X_1" Z="Z_1" />

```



```

<O T="Point" Y="Y_os" X="X_os" Z="Z_os" />
<O T="Section">
  <O T="Circle">
    <P N="Segments" V="Refinement" />
    <P N="Radius" V="d_s/2" UT="Length" UC="Properties" />
  </O>
</O>
</O>
<O N="HexNut" T="Volume">
  <P N="Color" V="#b60000" T="Text" />
  <O T="Point" Y="Y_2" X="X_2" Z="Z_2" />
  <O T="Point" Y="Y_on" X="X_on" Z="Z_on" />
  <O T="Section">
    <O T="Circle">
      <P N="Segments" V="6" />
      <P N="Radius" V="d_n/2" UT="Length" UC="Properties" />
    </O>
    <O T="Circle">
      <P N="IsCutout" V="1" />
      <P N="Segments" V="Refinement" />
      <P N="Radius" V="d_s/2+d_s*0.01" UT="Length" UC="Properties" />
    </O>
  </O>
</O>
</O>
</O>

```

**Bolt Group (BB)**

The Bolt Group (BB) object is a collection of bolts spaced in a rectangular grid. The bolt spacing in the two directions may be different, but all spaces in each direction are constant.

open BrIM BoltGroup (BB) BY BENJAMIN BLASEN

Refresh

Params

ROWS number of rows in this bolt group.	COLS number of columns in this bolt group.	col_spacing the spacing between columns
3	3	5
row_spacing the spacing between columns	thickness distance between the inner surfaces of the nut and the head.	bolt_ds Diameter of the shaft of the bolt.
5	2	0.75
bolt_dh Diameter of the head of the bolt.	bolt_dn Diameter of the nut of the bolt.	bolt_th Thickness of the head.
1.4375	1.4375	$\frac{15}{32} = 0.4688$
bolt_tn Thickness of the nut.		
$\frac{47}{64} = 0.7344$		

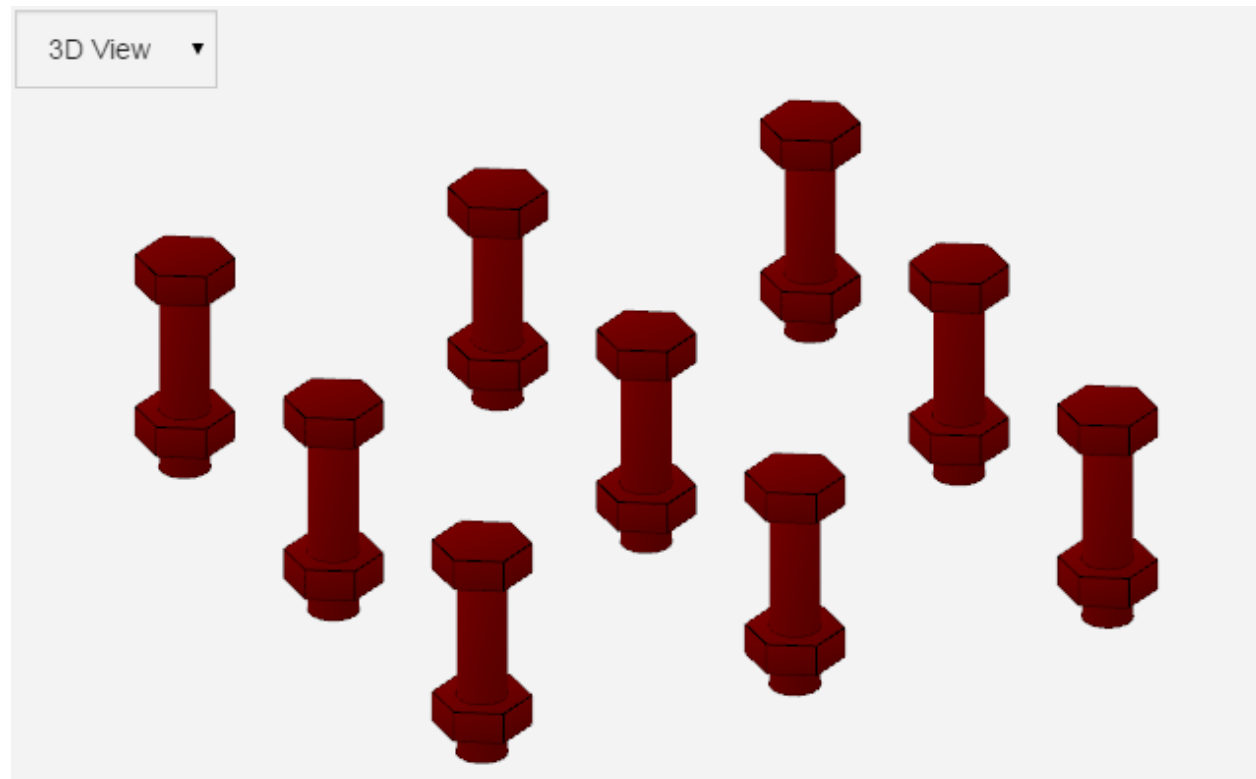

ParamML Code

```

<O N="BoltGroup (BB)" T="Project">
  <P N="rows" V="3" D="number of rows in this bolt group." Role="Input" />
  <P N="cols" V="3" D="number of columns in this bolt group." Role="Input" />
  <P N="col_spacing" V="5" D="the spacing between columns" Role="Input" UT="Length" UC="Properties" />
  <P N="row_spacing" V="5" D="the spacing between columns" Role="Input" UT="Length" UC="Properties" />
  <P N="thickness" V="2" D="distance between the inner surfaces of the nut and the head." Role="Input"
  UT="Length" UC="Properties" />
  <P N="bolt_ds" V="0.75" D="Diameter of the shaft of the bolt." Role="Input" UT="Length" UC="Properties" />
  <P N="bolt_dh" V="1.4375" D="Diameter of the head of the bolt." Role="Input" UT="Length" UC="Properties" />
  <P N="bolt_dn" V="1.4375" D="Diameter of the nut of the bolt." Role="Input" UT="Length" UC="Properties" />
  <P N="bolt_th" V="15/32" D="Thickness of the head." Role="Input" UT="Length" UC="Properties" />
  <P N="bolt_tn" V="47/64" D="Thickness of the nut." Role="Input" UT="Length" UC="Properties" />
  <O N="ObjDesc" T="Group">
    <!--
  <p> |BoltGroup (BB)| object is a collection of |Bolt (BB)| objects.
  </p>
  <br> Created by <i>Ali Koc</i> on 5/29/2015 </br>
  <br> Updated by <i>Benjamin Blasen</i> on 12/18/2015 </br>

-->
</O>
<O N="Row" T="Repeat">
  <P N="S" V="0" />
  <P N="E" V="rows-1" />
  <P N="I" V="1" />
  <P N="CTRL" V="row" T="Text" />
  <P N="row" V="0" />
  <O N="Col" T="Repeat">
    <P N="S" V="0" />
    <P N="E" V="cols-1" />
    <P N="I" V="1" />
    <P N="CTRL" V="col" T="Text" />
    <P N="col" V="0" />
  <O T="Bolt (BB)">
    <P N="X_1" V="col_spacing*col" D="X location of the first point." />
    <P N="Y_1" V="row_spacing*row" D="Y location of the first point." />
    <P N="Z_1" V="0" D="Z location of the first point." />
    <P N="X_2" V="col_spacing*col" D="X location of the second point." />
    <P N="Y_2" V="row_spacing*row" D="Y location of the second point." />
    <P N="Z_2" V="-thickness" D="Z location of the second point." />
    <P N="d_s" V="bolt_ds" D="Diameter of the shaft of the bolt." />
    <P N="d_h" V="bolt_dh" D="Diameter of the head of the bolt." />
    <P N="d_n" V="bolt_dn" D="Diameter of the nut of the bolt." />
    <P N="t_h" V="bolt_th" D="Thickness of the head." />
    <P N="t_n" V="bolt_tn" D="Thickness of the nut." />
  </O>
</O>
</O>
</O>
</O>

```

**Shear Stud**

The Shear Stud object represents a shear connector welded to the top flange of a steel girder. It consists of a circular shaft and a larger diameter circular head. Both shaft and head are defined as Volume objects constructed using the Circle object between two points.

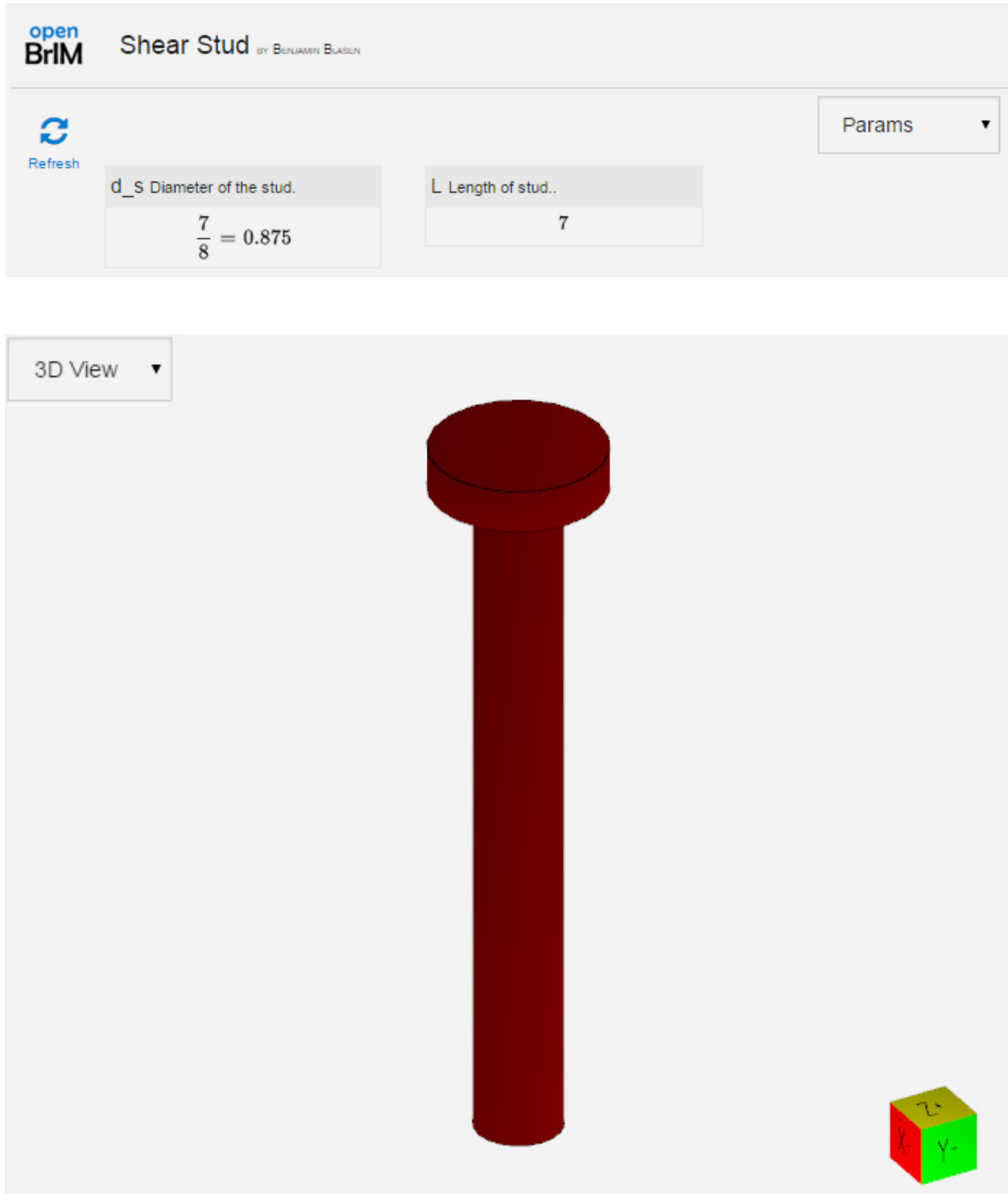

ParamML Code

```

<O N="Shear Stud" T="Project">
  <P N="ObjLabel" V="Shear Stud" T="Text" />
  <P N="d_s" V="7/8" D="Diameter of the stud." Role="Input" UT="Length" UC="Properties" />
  <P N="L" V="7" D="Length of stud.." Role="Input" UT="Length" UC="Properties" />
  <P N="t_h" V="d_s/2" D="Thickness of the head." UT="Length" UC="Properties" />
  <P N="Refinement" V="9" D="Level of detail." />
  <O N="ObjDesc" T="Group">
    <!--
    <p> |Shear Stud| is a simple steel stud.
    </p> -->
    <!--
  <p>
    <i>Created <b>Benjamin Blasen</b> on 7/10/2015 </i>

  <br>Limitations:
  1) Does not create threaded studs.
  2) Stud head diameter and thickness are a function of the shaft diameter.
  </br></p>
  -->
</O>
<O N="StudHead" T="Volume">
  <P N="Color" V="#b60000" T="Text" />
  <O T="Circle" Z="L">
    <P N="Segments" V="Refinement" />
    <P N="Radius" V="d_s" />
  </O>
  <O T="Circle" Z="t_h+L">
    <P N="Segments" V="Refinement" />
    <P N="Radius" V="d_s" />
  </O>
</O>
<O N="StudShaft" T="Volume">
  <P N="Color" V="#b60000" T="Text" />
  <P N="DrawBorder" V="0" />
  <P N="DrawFaceA" V="0" />
  <P N="DrawFaceABorder" V="1" />
  <O T="Circle" Z="L">
    <P N="Segments" V="Refinement" />
    <P N="Radius" V="d_s/2" />
  </O>
  <O T="Circle" Z="0">
    <P N="Segments" V="Refinement" />
    <P N="Radius" V="d_s/2" />
  </O>
</O>
</O>

```

## Stud Placement

The Stud Placement object is used to space groups of Shear Stud objects along the length of a steel girder. Objects can be spaced in multiple groups with variable spacing.

```
<O N="Stud Placement" T="Project">
  <P N="dia_s" V="7/8" D="Diameter of the stud, in." Role="Input" />
  <P N="len_s" V="7" D="Length of stud, in." Role="Input" />
  <P N="Stud_Spacing" V="[5, 10, 30, 5]" D="Spacing in-between studs, in." Role="Input" />
  <P N="Spacing_Length" V="[15, 200, 150, 15]" D="Total length of each spacing, in." Role="Input" />
  <O N="ObjDesc" T="Group">
    <!--
    <p> |Stud Placement| object is used to call "Shear Stud" library object
    and place it in a row based on a given spacing and length. Alignment of the
```

```

row of studs can be specified in the project.</p>
-->
<!-- <i>created by <b>Benjamin Blasen</b> on 7/13/2015</i> -->
</O>
<!-- Reset of spacing parameters required.-->
<O T="Group">
  <O N="xd" T="Repeat" CTRL="ri" I="1" E="length(Stud_Spacing)+1" S="0" ri="0">
    <P N="Tot" V="0" />
  </O>
</O>
<O T="Group">
  <O N="xd" T="Repeat" CTRL="i" I="1" E="length(Stud_Spacing)+1" S="0" i="0">
    <O T="Group">
      <P N="Guard" V="i.LE. 0" />
      <P N="Tot" V="0" />
    </O>
    <O T="Group">
      <P N="Guard" V="i.GT. 0" />
      <P N="Tot" V="Spacing_Length[i-1] + xd[i-1].Tot" />
    </O>
  </O>
  <O T="Repeat" S="0" E="length(Stud_Spacing)" I="1" CTRL="ai" ai="0">
    <O T="Repeat" S="1" E="floor((Spacing_Length[ai]+.01)/(Stud_Spacing[ai]+.01))+1" I="1" CTRL="sdi"
sdi="0">
      <O T="Group">
        <P N="Guard" V="ai.LE. 0" />
        <O T="Shear Stud" X="(Stud_Spacing[ai]*sdi)" AlignH="None" AlignV="None">
          <P N="d_s" V="dia_s" />
          <P N="L" V="len_s" />
        </O>
      </O>
      <O T="Group">
        <P N="Guard" V="ai.GT. 0" />
        <O T="Shear Stud" X="(Stud_Spacing[ai]*sdi)+xd[ai].Tot" AlignH="None" AlignV="None">
          <P N="d_s" V="dia_s" />
          <P N="L" V="len_s" />
        </O>
      </O>
    </O>
  </O>
</O>
</O>
</O>
</O>

```

## CrossFrameTypeKTop

CrossFrameTypeKTop object is used for steel K-Type cross frame objects placed between steel plate I-girders. The basic geometry is defined by work point offsets from the top and bottom of web at the girder centerline. This configuration uses horizontal top and bottom chords, and two diagonals that intersect at the mid-length of the top chord. Chords and Diagonals are constructed from Line objects. The chords and diagonals are connected by welds to gusset plates. The four corner gusset plates include holes for a bolt group to be connected to stiffeners on the girders. The top center gusset plate is connected by welds only to the top chord and diagonals. The corner gusset plates reference the library object BoltedGusset, and the top center gusset plate uses the library object WeldedGusset. When positioned in a project with an alignment, the cross frame orientation racks to take into account any variable cross slope.

open BrIM CrossFrameTypeKTop BY MIKE BARTHOLEMEW

Refresh

Cross Frame Geometry

GirderA_Horiz_Offset Girder A (Right) CL Offset from HCL	GirderB_Horiz_Offset Girder B (Left) CL Offset from HCL	TopWP_Vert_Offset Top Work Point offset from top of Girder web
-57	57	10
TopWP_Horiz_Offset Top Work Point offset from CL of Girder web	BotWP_Vert_Offset Bottom Work Point offset from bottom of Girder web	BotWP_Horiz_Offset Bottom Work Point offset from CL of Girder web
0	7.5	0

open BrIM CrossFrameTypeKTop BY MIKE BARTHOLEMEW

Refresh

Gusset Plate Data

TopGusset_H	TopGusset_V	TopBoltGroupCols number of cols
14	9.5	2
TopBoltGroupRows number of rows	TopBoltGroupSpY Horiz spacing between columns	TopBoltGroupSpZ Vert spacing between rows
3	3	3
BottomGusset_H	BottomGusset_V	BottomBoltGroupCols number of cols
14	15.5	2
BottomBoltGroupRows number of rows	BottomBoltGroupSpY Horiz spacing between columns	BottomBoltGroupSpZ Vert spacing between rows
5	3	3
CenterGusset_H	CenterGusset_V	thickness Thickness of Gusset Plates
20	12	0.5



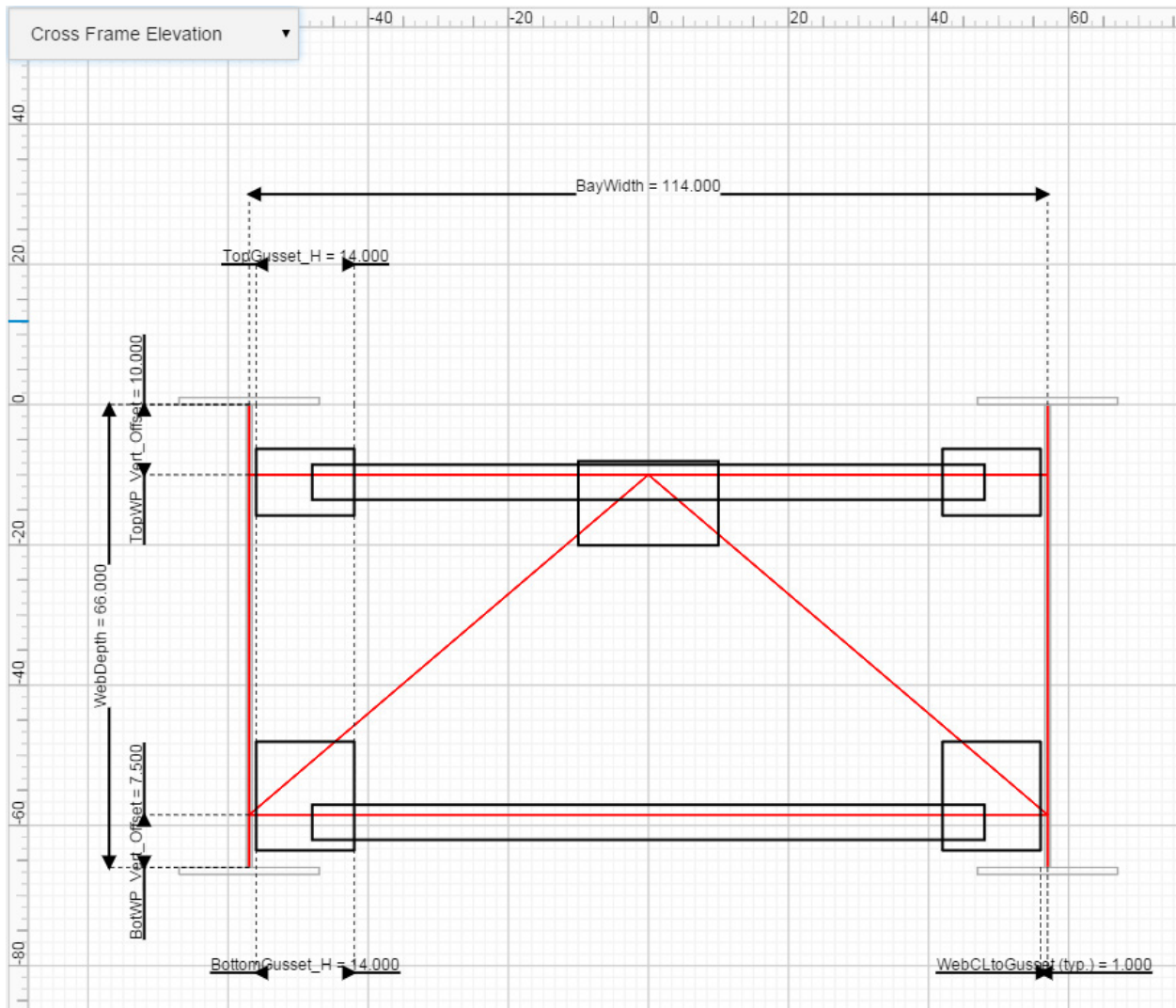

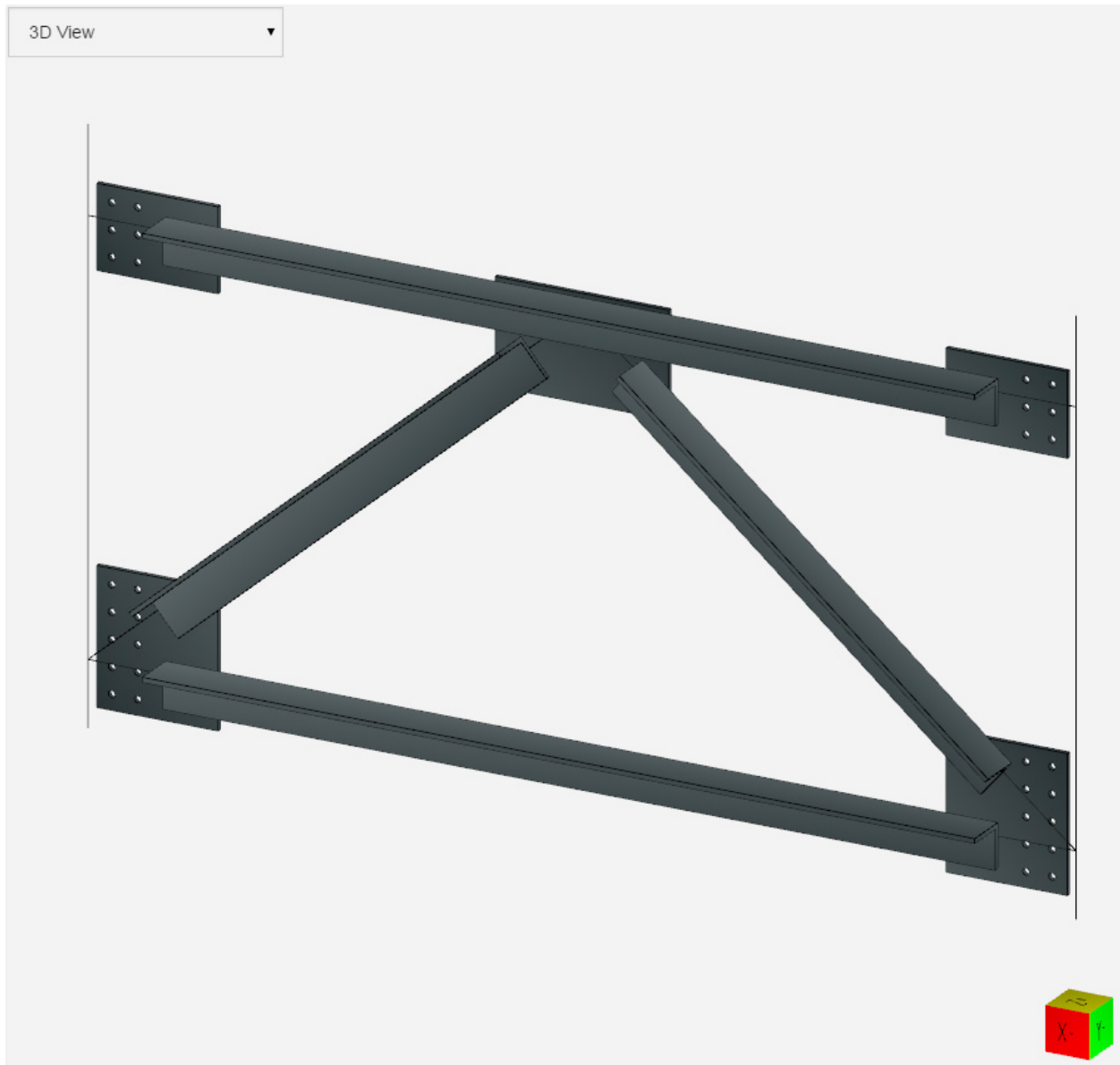

### ParamML Code

```
<O N="CrossFrameTypeKTop" T="Project">
  <!-- created by Mike Bartholomew on 7/8/2015 -->
  <!--
-->
```

```
  <O N="ObjDesc" T="Group">
    <!--
```

<p> |CrossFrameTypeKTop| object is used for steel K-Type cross frame objects placed between steel plate I-girders. The basic geometry is defined by work point offsets from the top and bottom of web at the girder centerline. This configuration uses horizontal top and bottom chords, and two diagonals that intersect at the mid-length of the top chord. Chords and Diagonals are constructed from Line objects. The chords and diagonals are connected by welds to gusset plates. The four corner gusset plates include holes for a bolt group to be connected to stiffeners on the girders. The top center gusset plate is connected by welds only to the top chord and diagonals. The corner gusset plates reference the library object | BoltedGusset |, and the top

center gusset plate uses the library object |WeldedGusset|. When positioned in a project with an alignment, the cross frame orientation racks to take into account any variable cross slope.

```

</p>
-->
</O>
<O N="Cross Frame Geometry" T="Group">
  <P N="XFStation" V="0" />
  <P N="GirderA_Horiz_Offset" V="-57" D="Girder A (Right) CL Offset from HCL" Role="Input" Category="Cross
Frame Geometry" />
  <P N="GirderB_Horiz_Offset" V="57" D="Girder B (Left) CL Offset from HCL" Role="Input" Category="Cross
Frame Geometry" />
  <P N="Baywidth" V="GirderB_Horiz_Offset-GirderA_Horiz_Offset" />
  <P N="TopWP_Vert_Offset" V="10" D="Top Work Point offset from top of Girder web" Role="Input"
Category="Cross Frame Geometry" />
  <P N="TopWP_Horiz_Offset" V="0" D="Top Work Point offset from CL of Girder web" Role="Input"
Category="Cross Frame Geometry" />
  <P N="BotWP_Vert_Offset" V="7.5" D="Bottom Work Point offset from bottom of Girder web" Role="Input"
Category="Cross Frame Geometry" />
  <P N="BotWP_Horiz_Offset" V="0" D="Bottom Work Point offset from CL of Girder web" Role="Input"
Category="Cross Frame Geometry" />
  <P N="WebDepth" V="66" />
  <P N="WebCLtoGusset" V="1" />
  <P N="GA" V="alignT(Alignment, XFStation, GirderA_Horiz_Offset)" D="Left Girder global Z" />
  <P N="GB" V="alignT(Alignment, XFStation, GirderB_Horiz_Offset)" D="Right Girder global Z" />
  <P N="CL" V="alignT(Alignment, XFStation, (GirderA_Horiz_Offset+GirderB_Horiz_Offset)/2)" D="CL Cross
Frame global Z" />
  <P N="ElevCorr" V="(GA+GB)/2-CL" />
  <P N="AngleCorr" V="(GA-GB)/(GirderA_Horiz_Offset-GirderB_Horiz_Offset)" />
  <P N="LeftDiagAngle" V="atan((WP5.Z-WP3.Z)/(WP5.Y-WP3.Y))" />
  <P N="RightDiagAngle" V="atan((WP5.Z-WP4.Z)/(WP5.Y-WP4.Y))" />
  <O N="WP1" T="Point" X="-t/2" Y="GirderA_Horiz_Offset+TopWP_Horiz_Offset" Z="-TopWP_Vert_Offset" />
  <O N="WP2" T="Point" X="-t/2" Y="GirderB_Horiz_Offset-TopWP_Horiz_Offset" Z="-TopWP_Vert_Offset" />
  <O N="WP3" T="Point" X="-t/2" Y="GirderA_Horiz_Offset+BotWP_Horiz_Offset" Z="-
WebDepth+BotWP_Vert_Offset" />
  <O N="WP4" T="Point" X="-t/2" Y="GirderB_Horiz_Offset-BotWP_Horiz_Offset" Z="-
WebDepth+BotWP_Vert_Offset" />
  <O N="WP5" T="Point" X="-t/2" Y="(GirderB_Horiz_Offset+GirderA_Horiz_Offset)/2"
Z="(WP1.Z+WP2.Z)/2+ElevCorr" />
</O>
<O N="Gusset Plate Data" T="Group">
  <P N="TopGusset_H" V="14" Role="Input" Category="Gusset Plate Data" />
  <P N="TopGusset_V" V="9.5" Role="Input" Category="Gusset Plate Data" />
  <P N="TopBoltGroupCols" V="2" D="number of cols" Role="Input" Category="Gusset Plate Data" />
  <P N="TopBoltGroupRows" V="3" D="number of rows" Role="Input" Category="Gusset Plate Data" />
  <P N="TopBoltGroupSpY" V="3" D="Horiz spacing between columns" Role="Input" Category="Gusset Plate
Data" />
  <P N="TopBoltGroupSpZ" V="3" D="Vert spacing between rows" Role="Input" Category="Gusset Plate Data" />
  <P N="BottomGusset_H" V="14" Role="Input" Category="Gusset Plate Data" />
  <P N="BottomGusset_V" V="15.5" Role="Input" Category="Gusset Plate Data" />
  <P N="BottomBoltGroupCols" V="2" D="number of cols" Role="Input" Category="Gusset Plate Data" />
  <P N="BottomBoltGroupRows" V="5" D="number of rows" Role="Input" Category="Gusset Plate Data" />
  <P N="BottomBoltGroupSpY" V="3" D="Horiz spacing between columns" Role="Input" Category="Gusset Plate
Data" />
  <P N="BottomBoltGroupSpZ" V="3" D="Vert spacing between rows" Role="Input" Category="Gusset Plate
Data" />

```

```

<P N="CenterGusset_H" V="20" Role="Input" Category="Gusset Plate Data" />
<P N="CenterGusset_V" V="12" Role="Input" Category="Gusset Plate Data" />
<P N="thickness" V="0.5" D="Thickness of Gusset Plates" Role="Input" Category="Gusset Plate Data" />
<P N="GussetA" V="alignT(Alignment, XFStation-t/2, WP1.Y+8)" D="Right Gusset global Z" />
<P N="GussetAElevCorr" V="GussetA-GA" />
<P N="GussetB" V="alignT(Alignment, XFStation-t/2, WP2.Y-8)" D="Left Gusset global Z" />
<P N="GussetBElevCorr" V="GussetB-GB" />
<P N="BoltDia" V="0.75" D="Diameter of bolt" />
<P N="EdgeDist" V="1.75" D="Distance from edge of Plate to CL of Bolt Hole" />
</O>
<O N="DefaultSection" T="Section" RZ="0">
  <P N="t" V="0.5" />
  <P N="b" V="5" />
  <P N="d" V="5" />
  <P N="x" V="1.4375" D="CG about X-axis" />
  <P N="y" V="1.4375" D="CG about Y-axis" />
  <O T="Shape">
    <O T="Point" X="0" Y="0" />
    <O T="Point" X="b" Y="0" />
    <O T="Point" X="b" Y="t" />
    <O T="Point" X="t" Y="t" />
    <O T="Point" X="t" Y="d" />
    <O T="Point" X="0" Y="d" />
  </O>
</O>
<O N="Cross Frame Member Data" T="Group">
  <P N="TopChord" V="DefaultSection" T="Section" />
  <P N="BotChord" V="DefaultSection" T="Section" />
  <P N="Diagonal" V="DefaultSection" T="Section" />
</O>
<O N="Cross Frame" T="Group">
  <O N="Gusset1" T="BoltedGusset" AlignH="Orient" AlignV="Orient" AlignT="None" X="thickness/2"
Y="WP1.Y+8" Z="WP1.Z-TopChord.d/2+TopChord.y-GussetAElevCorr" RX="Pl">
    <P N="w" V="TopGusset_H" D="width of the plate" />
    <P N="h" V="TopGusset_V" D="height of the plate" />
    <P N="t_g" V="thickness" D="thickness of the plate" />
    <P N="nrows" V="TopBoltGroupRows" D="number of rows" />
    <P N="ncols" V="TopBoltGroupCols" D="number of columns" />
    <P N="spY" V="TopBoltGroupSpY" D="Horiz spacing between columns" />
    <P N="spZ" V="TopBoltGroupSpZ" D="Vert spacing between rows" />
    <P N="d_b" V="BoltDia" D="Bolt Diameter" />
    <P N="c" V="EdgeDist" D="Distance from edge of Plate to CL of Bolt Hole" />
  </O>
  <O N="Gusset2" T="BoltedGusset" AlignH="Orient" AlignV="Orient" AlignT="None" X="thickness/2" Y="WP2.Y-
8" Z="WP2.Z-TopChord.d/2+TopChord.y-GussetBElevCorr">
    <P N="w" V="TopGusset_H" D="width of the plate" />
    <P N="h" V="TopGusset_V" D="height of the plate" />
    <P N="t_g" V="thickness" D="thickness of the plate" />
    <P N="nrows" V="TopBoltGroupRows" D="number of rows" />
    <P N="ncols" V="TopBoltGroupCols" D="number of columns" />
    <P N="spY" V="TopBoltGroupSpY" D="Horiz spacing between columns" />
    <P N="spZ" V="TopBoltGroupSpZ" D="Vert spacing between rows" />
    <P N="d_b" V="BoltDia" D="Bolt Diameter" />
    <P N="c" V="EdgeDist" D="Distance from edge of Plate to CL of Bolt Hole" />
  </O>
</O>

```

```

<O N="Gusset3" T="BoltedGusset" AlignH="Orient" AlignV="Orient" AlignT="None" X="thickness/2"
Y="WP3.Y+8" Z="WP3.Z+BottomGusset_V/2-BotChord.d+BotChord.y-1.5-GussetAElevCorr" RX="PI">
  <P N="w" V="BottomGusset_H" D="width of the plate" />
  <P N="h" V="BottomGusset_V" D="height of the plate" />
  <P N="t_g" V="thickness" D="thickness of the plate" />
  <P N="nrows" V="BottomBoltGroupRows" D="number of rows" />
  <P N="ncols" V="BottomBoltGroupCols" D="number of columns" />
  <P N="spY" V="BottomBoltGroupSpY" D="Horiz spacing between columns" />
  <P N="spZ" V="BottomBoltGroupSpZ" D="Vert spacing between rows" />
  <P N="d_b" V="BoltDia" D="Bolt Diameter" />
  <P N="c" V="EdgeDist" D="Distance from edge of Plate to CL of Bolt Hole" />
</O>
<O N="Gusset4" T="BoltedGusset" AlignH="Orient" AlignV="Orient" AlignT="None" X="thickness/2" Y="WP4.Y-
8" Z="WP4.Z+BottomGusset_V/2-BotChord.d+BotChord.y-1.5-GussetBElevCorr">
  <P N="w" V="BottomGusset_H" D="width of the plate" />
  <P N="h" V="BottomGusset_V" D="height of the plate" />
  <P N="t_g" V="thickness" D="thickness of the plate" />
  <P N="nrows" V="BottomBoltGroupRows" D="number of rows" />
  <P N="ncols" V="BottomBoltGroupCols" D="number of columns" />
  <P N="spY" V="BottomBoltGroupSpY" D="Horiz spacing between columns" />
  <P N="spZ" V="BottomBoltGroupSpZ" D="Vert spacing between rows" />
  <P N="d_b" V="BoltDia" D="Bolt Diameter" />
  <P N="c" V="EdgeDist" D="Distance from edge of Plate to CL of Bolt Hole" />
</O>
<O N="Gusset5" T="WeldedGusset" AlignH="Orient" AlignV="Orient" AlignT="None" X="thickness/2"
Y="WP5.Y" Z="WP5.Z+TopChord.y+0.5-CenterGusset_V/2" RX="AngleCorr">
  <P N="w" V="CenterGusset_H" D="width of the plate" />
  <P N="h" V="CenterGusset_V" D="height of the plate" />
  <P N="t_g" V="thickness" D="thickness of the plate" />
</O>
<O N="Top Chord" T="Line" AlignH="None" AlignV="None" AlignT="None">
  <P N="Section" V="TopChord" T="Section" />
  <P N="BetaAngle" V="PI" />
  <P N="StartOffsetX" V="9" />
  <P N="EndOffsetX" V="-9" />
  <P N="StartOffsetZ" V="TopChord.y" />
  <P N="EndOffsetZ" V="TopChord.y" />
  <O T="Point" X="WP1.X" Y="WP1.Y" Z="WP1.Z" />
  <O T="Point" X="WP2.X" Y="WP2.Y" Z="WP2.Z" />
</O>
<O N="Bottom Chord" T="Line" AlignH="None" AlignV="None" AlignT="None">
  <P N="Section" V="BotChord" T="Section" />
  <P N="BetaAngle" V="PI" />
  <P N="StartOffsetX" V="9" />
  <P N="EndOffsetX" V="-9" />
  <P N="StartOffsetZ" V="BotChord.y" />
  <P N="EndOffsetZ" V="BotChord.y" />
  <O T="Point" X="WP3.X" Y="WP3.Y" Z="WP3.Z" />
  <O T="Point" X="WP4.X" Y="WP4.Y" Z="WP4.Z" />
</O>
<O N="Left Diagonal" T="Line" AlignH="None" AlignV="None" AlignT="None">
  <P N="Section" V="Diagonal" T="Section" />
  <P N="BetaAngle" V="PI" />
  <P N="StartOffsetX" V="11" />
  <P N="EndOffsetX" V="-8" />
  <P N="StartOffsetZ" V="Diagonal.y" />

```

```

    <P N="EndOffsetZ" V="Diagonal.y" />
    <O T="Point" X="WP3.X" Y="WP3.Y" Z="WP3.Z" />
    <O T="Point" X="WP5.X" Y="WP5.Y" Z="WP5.Z" />
</O>
<O N="Right Diagonal" T="Line" AlignH="None" AlignV="None" AlignT="None">
    <P N="Section" V="Diagonal" T="Section" />
    <P N="BetaAngle" V="PI" />
    <P N="StartOffsetX" V="8" />
    <P N="EndOffsetX" V="-11" />
    <P N="StartOffsetZ" V="Diagonal.y" />
    <P N="EndOffsetZ" V="Diagonal.y" />
    <O T="Point" X="WP5.X" Y="WP5.Y" Z="WP5.Z" />
    <O T="Point" X="WP4.X" Y="WP4.Y" Z="WP4.Z" />
</O>
<!--
The Working Lines are for debugging purposes
-->
<O T="Private">
    <O N="Working Lines" T="Group">
        <P N="Color" V="#FF0000" T="Hex" />
        <O N="Simple Line" T="Section">
            <P N="w" V="0.003" />
            <P N="h" V="0.003" />
            <O T="Shape">
                <O T="Point" X="-w/2" Y="-h/2" />
                <O T="Point" X="w/2" Y="-h/2" />
                <O T="Point" X="w/2" Y="h/2" />
                <O T="Point" X="-w/2" Y="h/2" />
            </O>
        </O>
        <O N="Top Chord Working Line" T="Line">
            <P N="Section" V="Simple Line" T="Section" />
            <O T="Point" X="-t/2" Y="WP1.Y" Z="WP1.Z" />
            <O T="Point" X="-t/2" Y="WP2.Y" Z="WP2.Z" />
        </O>
        <O N="Bottom Chord Working Line" T="Line">
            <P N="Section" V="Simple Line" T="Section" />
            <O T="Point" X="-t/2" Y="WP3.Y" Z="WP3.Z" />
            <O T="Point" X="-t/2" Y="WP4.Y" Z="WP4.Z" />
        </O>
        <O N="Left Diagonal Working Line" T="Line">
            <P N="Section" V="Simple Line" T="Section" />
            <O T="Point" X="-t/2" Y="WP3.Y" Z="WP3.Z" />
            <O T="Point" X="-t/2" Y="WP5.Y" Z="WP5.Z" />
        </O>
        <O N="Right Diagonal Working Line" T="Line">
            <P N="Section" V="Simple Line" T="Section" />
            <O T="Point" X="-t/2" Y="WP5.Y" Z="WP5.Z" />
            <O T="Point" X="-t/2" Y="WP4.Y" Z="WP4.Z" />
        </O>
        <O N="Left Girder CL" T="Line">
            <P N="Section" V="Simple Line" T="Section" />
            <O T="Point" X="-t/2" Y="WP1.Y" Z="WP1.Z+TopWP_Vert_Offset" />
            <O T="Point" X="-t/2" Y="WP3.Y" Z="WP3.Z-BotWP_Vert_Offset" />
        </O>
        <O N="Right Girder CL" T="Line">

```

```

    <P N="Section" V="Simple Line" T="Section" />
    <O T="Point" X="-t/2" Y="WP2.Y" Z="WP2.Z+TopWP_Vert_Offset" />
    <O T="Point" X="-t/2" Y="WP4.Y" Z="WP4.Z-BotWP_Vert_Offset" />
  </O>
</O>
</O>
</O>
<O N="Cross Frame Elevation" T="CADD" RX="PI/2" RZ="PI/2">
  <P N="Alignment" V="NULL" T="Aligment" />
  <O N="Left Girder CL" T="CADDLine">
    <P N="Thickness" V="1" />
    <P N="Color" V="#FF0000" T="Hex" />
    <O T="Point" X="-t/2" Y="WP1.Y" Z="WP1.Z+TopWP_Vert_Offset+(GA-CL)" />
    <O T="Point" X="-t/2" Y="WP3.Y" Z="WP3.Z-BotWP_Vert_Offset+(GA-CL)" />
  </O>
  <O N="Left Girder Web" T="CADDShape">
    <P N="IsClosed" V="T" T="Text" />
    <P N="Thickness" V="1" />
    <P N="Color" V="#AAAAAA" T="Hex" />
    <O T="Point" X="-t/2" Y="WP1.Y-0.375" Z="WP1.Z+TopWP_Vert_Offset+(GA-CL)" />
    <O T="Point" X="-t/2" Y="WP3.Y-0.375" Z="WP3.Z-BotWP_Vert_Offset+(GA-CL)" />
    <O T="Point" X="-t/2" Y="WP3.Y+0.375" Z="WP3.Z-BotWP_Vert_Offset+(GA-CL)" />
    <O T="Point" X="-t/2" Y="WP1.Y+0.375" Z="WP1.Z+TopWP_Vert_Offset+(GA-CL)" />
  </O>
  <O N="Left Girder Top Flange" T="CADDShape">
    <P N="IsClosed" V="T" T="Text" />
    <P N="Thickness" V="1" />
    <P N="Color" V="#AAAAAA" T="Hex" />
    <O T="Point" X="-t/2" Y="WP1.Y-10" Z="WP1.Z+TopWP_Vert_Offset+(GA-CL)" />
    <O T="Point" X="-t/2" Y="WP1.Y+10" Z="WP1.Z+TopWP_Vert_Offset+(GA-CL)" />
    <O T="Point" X="-t/2" Y="WP1.Y+10" Z="WP1.Z+TopWP_Vert_Offset+(GA-CL)+1" />
    <O T="Point" X="-t/2" Y="WP1.Y-10" Z="WP1.Z+TopWP_Vert_Offset+(GA-CL)+1" />
  </O>
  <O N="Left Girder Bottom Flange" T="CADDShape">
    <P N="IsClosed" V="T" T="Text" />
    <P N="Thickness" V="1" />
    <P N="Color" V="#AAAAAA" T="Hex" />
    <O T="Point" X="-t/2" Y="WP3.Y-10" Z="WP3.Z-BotWP_Vert_Offset+(GA-CL)" />
    <O T="Point" X="-t/2" Y="WP3.Y+10" Z="WP3.Z-BotWP_Vert_Offset+(GA-CL)" />
    <O T="Point" X="-t/2" Y="WP3.Y+10" Z="WP3.Z-BotWP_Vert_Offset+(GA-CL)-1" />
    <O T="Point" X="-t/2" Y="WP3.Y-10" Z="WP3.Z-BotWP_Vert_Offset+(GA-CL)-1" />
  </O>
  <!--
-->
  <O N="Right Girder CL" T="CADDLine">
    <P N="Thickness" V="1" />
    <P N="Color" V="#FF0000" T="Hex" />
    <O T="Point" X="-t/2" Y="WP2.Y" Z="WP2.Z+TopWP_Vert_Offset+(GB-CL)" />
    <O T="Point" X="-t/2" Y="WP4.Y" Z="WP4.Z-BotWP_Vert_Offset+(GB-CL)" />
  </O>
  <O N="Right Girder Web" T="CADDShape">
    <P N="IsClosed" V="T" T="Text" />
    <P N="Thickness" V="1" />
    <P N="Color" V="#AAAAAA" T="Hex" />
    <O T="Point" X="-t/2" Y="WP2.Y-0.375" Z="WP2.Z+TopWP_Vert_Offset+(GB-CL)" />
    <O T="Point" X="-t/2" Y="WP4.Y-0.375" Z="WP4.Z-BotWP_Vert_Offset+(GB-CL)" />
  </O>

```

```

    <O T="Point" X="-t/2" Y="WP4.Y+0.375" Z="WP4.Z-BotWP_Vert_Offset+(GB-CL)" />
    <O T="Point" X="-t/2" Y="WP2.Y+0.375" Z="WP2.Z+TopWP_Vert_Offset+(GB-CL)" />
</O>
<O N="Right Girder Top Flange" T="CADDShape">
  <P N="IsClosed" V="T" T="Text" />
  <P N="Thickness" V="1" />
  <P N="Color" V="#AAAAAA" T="Hex" />
  <O T="Point" X="-t/2" Y="WP2.Y-10" Z="WP2.Z+TopWP_Vert_Offset+(GB-CL)" />
  <O T="Point" X="-t/2" Y="WP2.Y+10" Z="WP2.Z+TopWP_Vert_Offset+(GB-CL)" />
  <O T="Point" X="-t/2" Y="WP2.Y+10" Z="WP2.Z+TopWP_Vert_Offset+(GB-CL)+1" />
  <O T="Point" X="-t/2" Y="WP2.Y-10" Z="WP2.Z+TopWP_Vert_Offset+(GB-CL)+1" />
</O>
<O N="Right Girder Bottom Flange" T="CADDShape">
  <P N="IsClosed" V="T" T="Text" />
  <P N="Thickness" V="1" />
  <P N="Color" V="#AAAAAA" T="Hex" />
  <O T="Point" X="-t/2" Y="WP4.Y-10" Z="WP4.Z-BotWP_Vert_Offset+(GB-CL)" />
  <O T="Point" X="-t/2" Y="WP4.Y+10" Z="WP4.Z-BotWP_Vert_Offset+(GB-CL)" />
  <O T="Point" X="-t/2" Y="WP4.Y+10" Z="WP4.Z-BotWP_Vert_Offset+(GB-CL)-1" />
  <O T="Point" X="-t/2" Y="WP4.Y-10" Z="WP4.Z-BotWP_Vert_Offset+(GB-CL)-1" />
</O>
<O N="Top Chord Working Line" T="CADDLine">
  <P N="Thickness" V="1" />
  <P N="Color" V="#FF0000" T="Hex" />
  <O T="Point" X="-t/2" Y="WP1.Y" Z="WP1.Z+(GA-CL)" />
  <O T="Point" X="-t/2" Y="WP2.Y" Z="WP2.Z+(GB-CL)" />
</O>
<O N="Bottom Chord Working Line" T="CADDLine">
  <P N="Thickness" V="1" />
  <P N="Color" V="#FF0000" T="Hex" />
  <O T="Point" X="-t/2" Y="WP3.Y" Z="WP3.Z+(GA-CL)" />
  <O T="Point" X="-t/2" Y="WP4.Y" Z="WP4.Z+(GB-CL)" />
</O>
<O N="Left Diagonal Working Line" T="CADDLine">
  <P N="Thickness" V="1" />
  <P N="Color" V="#FF0000" T="Hex" />
  <O T="Point" X="-t/2" Y="WP3.Y" Z="WP3.Z+(GA-CL)" />
  <O T="Point" X="-t/2" Y="WP5.Y" Z="WP5.Z" />
</O>
<O N="Right Diagonal Working Line" T="CADDLine">
  <P N="Thickness" V="1" />
  <P N="Color" V="#FF0000" T="Hex" />
  <O T="Point" X="-t/2" Y="WP5.Y" Z="WP5.Z" />
  <O T="Point" X="-t/2" Y="WP4.Y" Z="WP4.Z+(GB-CL)" />
</O>
<O N="Gusset1CADD" T="CADDShape" Y="WP1.Y" Z="WP1.Z">
  <P N="IsClosed" V="T" T="Text" />
  <P N="Thickness" V="2" />
  <P N="Color" V="#000000" T="Hex" />
  <O T="Point" Y="8+TopGusset_H/2" Z="-TopChord.d/2+TopChord.y-GussetAElevCorr+TopGusset_V/2+(GA-CL)" />
  <O T="Point" Y="8+TopGusset_H/2" Z="-TopChord.d/2+TopChord.y-GussetAElevCorr+TopGusset_V/2+(GA-CL)" />
  <O T="Point" Y="8+TopGusset_H/2" Z="-TopChord.d/2+TopChord.y-GussetAElevCorr-TopGusset_V/2+(GA-CL)" />

```



```

    <O T="Point" Y="8-TopGusset_H/2" Z="-TopChord.d/2+TopChord.y-GussetAElevCorr-TopGusset_V/2+(GA-
CL)" />
  </O>
  <O N="Gusset2CADD" T="CADDShape" X="-thickness/2" Y="WP2.Y" Z="WP2.Z">
    <P N="IsClosed" V="T" T="Text" />
    <P N="Thickness" V="2" />
    <P N="Color" V="#000000" T="Hex" />
    <O T="Point" Y="-8-TopGusset_H/2" Z="-TopChord.d/2+TopChord.y-GussetAElevCorr+TopGusset_V/2+(GB-
CL)" />
  </O>
  <O T="Point" Y="-8+TopGusset_H/2" Z="-TopChord.d/2+TopChord.y-GussetAElevCorr+TopGusset_V/2+(GB-
CL)" />
  <O T="Point" Y="-8+TopGusset_H/2" Z="-TopChord.d/2+TopChord.y-GussetAElevCorr-TopGusset_V/2+(GB-
CL)" />
  <O T="Point" Y="-8-TopGusset_H/2" Z="-TopChord.d/2+TopChord.y-GussetAElevCorr-TopGusset_V/2+(GB-
CL)" />
  </O>
  <O N="Gusset3CADD" T="CADDShape" X="-thickness/2" Y="WP3.Y" Z="WP3.Z">
    <P N="IsClosed" V="T" T="Text" />
    <P N="Thickness" V="2" />
    <P N="Color" V="#000000" T="Hex" />
    <O T="Point" Y="8-BottomGusset_H/2" Z="BottomGusset_V/2-BotChord.d+BotChord.y-1.5-
GussetAElevCorr+BottomGusset_V/2+(GA-CL)" />
  </O>
  <O T="Point" Y="8+BottomGusset_H/2" Z="BottomGusset_V/2-BotChord.d+BotChord.y-1.5-
GussetAElevCorr+BottomGusset_V/2+(GA-CL)" />
  <O T="Point" Y="8+BottomGusset_H/2" Z="BottomGusset_V/2-BotChord.d+BotChord.y-1.5-
GussetAElevCorr-BottomGusset_V/2+(GA-CL)" />
  <O T="Point" Y="8-BottomGusset_H/2" Z="BottomGusset_V/2-BotChord.d+BotChord.y-1.5-
GussetAElevCorr-BottomGusset_V/2+(GA-CL)" />
  </O>
  <O N="Gusset4CADD" T="CADDShape" X="-thickness/2" Y="WP4.Y" Z="WP4.Z">
    <P N="IsClosed" V="T" T="Text" />
    <P N="Thickness" V="2" />
    <P N="Color" V="#000000" T="Hex" />
    <O T="Point" Y="-8-BottomGusset_H/2" Z="BottomGusset_V/2-BotChord.d+BotChord.y-1.5-
GussetAElevCorr+BottomGusset_V/2+(GB-CL)" />
  </O>
  <O T="Point" Y="-8+BottomGusset_H/2" Z="BottomGusset_V/2-BotChord.d+BotChord.y-1.5-
GussetAElevCorr+BottomGusset_V/2+(GB-CL)" />
  <O T="Point" Y="-8+BottomGusset_H/2" Z="BottomGusset_V/2-BotChord.d+BotChord.y-1.5-
GussetAElevCorr-BottomGusset_V/2+(GB-CL)" />
  <O T="Point" Y="-8-BottomGusset_H/2" Z="BottomGusset_V/2-BotChord.d+BotChord.y-1.5-
GussetAElevCorr-BottomGusset_V/2+(GB-CL)" />
  </O>
  <O N="Gusset5CADD" T="CADDShape" X="-thickness/2" Y="WP5.Y" Z="WP5.Z" RX="-AngleCorr">
    <P N="IsClosed" V="T" T="Text" />
    <P N="Thickness" V="2" />
    <P N="Color" V="#000000" T="Hex" />
    <O T="Point" Y="-CenterGusset_H/2" Z="TopChord.y+0.5-CenterGusset_V/2-
GussetAElevCorr+CenterGusset_V/2" />
  </O>
  <O T="Point" Y="CenterGusset_H/2" Z="TopChord.y+0.5-CenterGusset_V/2-
GussetAElevCorr+CenterGusset_V/2" />
  <O T="Point" Y="CenterGusset_H/2" Z="TopChord.y+0.5-CenterGusset_V/2-GussetAElevCorr-
CenterGusset_V/2" />
  <O T="Point" Y="-CenterGusset_H/2" Z="TopChord.y+0.5-CenterGusset_V/2-GussetAElevCorr-
CenterGusset_V/2" />
  </O>
  <O N="TopChordCADD" T="CADDShape" X="-thickness/2" Y="WP5.Y" Z="WP5.Z" RX="-AngleCorr">

```

```

    <P N="IsClosed" V="T" T="Text" />
    <P N="Thickness" V="2" />
    <P N="Color" V="#000000" T="Hex" />
    <O T="Point" Y="-(GirderB_Horiz_Offset-GirderA_Horiz_Offset)/2+9" Z="1.44-GussetAElevCorr" />
    <O T="Point" Y="(GirderB_Horiz_Offset-GirderA_Horiz_Offset)/2-9" Z="1.44-GussetAElevCorr" />
    <O T="Point" Y="(GirderB_Horiz_Offset-GirderA_Horiz_Offset)/2-9" Z="-5+1.44-GussetAElevCorr" />
    <O T="Point" Y="-(GirderB_Horiz_Offset-GirderA_Horiz_Offset)/2+9" Z="-5+1.44-GussetAElevCorr" />
</O>
<O N="BotChordCADD" T="CADDShape" X="-thickness/2" Y="WP5.Y" Z="WP5.Z-48.5" RX="-AngleCorr">
    <P N="IsClosed" V="T" T="Text" />
    <P N="Thickness" V="2" />
    <P N="Color" V="#000000" T="Hex" />
    <O T="Point" Y="-(GirderB_Horiz_Offset-GirderA_Horiz_Offset)/2+9" Z="1.44-GussetAElevCorr" />
    <O T="Point" Y="(GirderB_Horiz_Offset-GirderA_Horiz_Offset)/2-9" Z="1.44-GussetAElevCorr" />
    <O T="Point" Y="(GirderB_Horiz_Offset-GirderA_Horiz_Offset)/2-9" Z="-5+1.44-GussetAElevCorr" />
    <O T="Point" Y="-(GirderB_Horiz_Offset-GirderA_Horiz_Offset)/2+9" Z="-5+1.44-GussetAElevCorr" />
</O>
<!--
<O N="LeftDiagonalCADD" T="CADDShape" X="-thickness/2" Y="(WP5.Y+WP3.Y)/2" Z="(WP5.Z+WP3.Z)/2"
RX="-LeftDiagAngle-AngleCorr/2">
    <P N="IsClosed" V="T" T="Text" />
    <P N="Thickness" V="2" />
    <P N="Color" V="#000000" T="Hex" />
    <O T="Point" Y="-(GirderB_Horiz_Offset-GirderA_Horiz_Offset)/2+9" Z="1.44" />
    <O T="Point" Y="(GirderB_Horiz_Offset-GirderA_Horiz_Offset)/2-9" Z="1.44" />
    <O T="Point" Y="(GirderB_Horiz_Offset-GirderA_Horiz_Offset)/2-9" Z="-5+1.44" />
    <O T="Point" Y="-(GirderB_Horiz_Offset-GirderA_Horiz_Offset)/2+9" Z="-5+1.44" />
</O>
<O N="RightDiagonalCADD" T="CADDShape" X="-thickness/2" Y="(WP5.Y+WP4.Y)/2" Z="(WP5.Z+WP4.Z)/2"
RX="-RightDiagAngle-AngleCorr/2">
    <P N="IsClosed" V="T" T="Text" />
    <P N="Thickness" V="2" />
    <P N="Color" V="#000000" T="Hex" />
    <O T="Point" Y="-(GirderB_Horiz_Offset-GirderA_Horiz_Offset)/2+9" Z="1.44-GussetAElevCorr" />
    <O T="Point" Y="(GirderB_Horiz_Offset-GirderA_Horiz_Offset)/2-9" Z="1.44-GussetAElevCorr" />
    <O T="Point" Y="(GirderB_Horiz_Offset-GirderA_Horiz_Offset)/2-9" Z="-5+1.44-GussetAElevCorr" />
    <O T="Point" Y="-(GirderB_Horiz_Offset-GirderA_Horiz_Offset)/2+9" Z="-5+1.44-GussetAElevCorr" />
</O>
-->
<O T="CADDDimensionLine">
    <P N="Label" V="TopWP_Vert_Offset = %d" T="Text" />
    <O T="Point" Y="GirderA_Horiz_Offset" Z="-TopWP_Vert_Offset+(GA-CL)" />
    <O T="Point" Y="GirderA_Horiz_Offset" Z="GA-CL" />
    <O T="Point" Y="GirderA_Horiz_Offset-15" Z="GA-CL" />
</O>
<O T="CADDDimensionLine">
    <P N="Label" V="BotWP_Vert_Offset = %d" T="Text" />
    <O T="Point" Y="GirderA_Horiz_Offset" Z="GA-CL-WebDepth" />
    <O T="Point" Y="GirderA_Horiz_Offset" Z="GA-CL-WebDepth+BotWP_Vert_Offset" />
    <O T="Point" Y="GirderA_Horiz_Offset-15" Z="GA-CL" />
</O>
<O T="CADDDimensionLine">
    <P N="Label" V="WebDepth = %d" T="Text" />
    <O T="Point" Y="GirderA_Horiz_Offset" Z="GA-CL-WebDepth" />
    <O T="Point" Y="GirderA_Horiz_Offset" Z="GA-CL" />
    <O T="Point" Y="GirderA_Horiz_Offset-20" Z="GA-CL" />

```

```

</O>
<O T="CADDDimensionLine">
  <P N="Label" V="BayWidth = %d" T="Text" />
  <O T="Point" Y="GirderA_Horiz_Offset" Z="GA-CL" />
  <O T="Point" Y="GirderB_Horiz_Offset" Z="GA-CL" />
  <O T="Point" Y="0" Z="30" />
</O>
<O T="CADDDimensionLine">
  <P N="Label" V="WebCLtoGusset (typ.) = %d" T="Text" />
  <O T="Point" Y="GirderB_Horiz_Offset-1" Z="-WebDepth+GA-CL" />
  <O T="Point" Y="GirderB_Horiz_Offset" Z="-WebDepth+GA-CL" />
  <O T="Point" Y="0" Z="-WebDepth-15" />
</O>
<O T="CADDDimensionLine">
  <P N="Label" V="TopGusset_H = %d" T="Text" />
  <O T="Point" Y="GirderA_Horiz_Offset+8-TopGusset_H/2" Z="GA-CL" />
  <O T="Point" Y="GirderA_Horiz_Offset+8+TopGusset_H/2" Z="GA-CL" />
  <O T="Point" Y="0" Z="20" />
</O>
<O T="CADDDimensionLine">
  <P N="Label" V="BottomGusset_H = %d" T="Text" />
  <O T="Point" Y="GirderA_Horiz_Offset+8-TopGusset_H/2" Z="GA-CL" />
  <O T="Point" Y="GirderA_Horiz_Offset+8+TopGusset_H/2" Z="GA-CL" />
  <O T="Point" Y="0" Z="-WebDepth-15" />
</O>
<O T="CADDDimensionLine">
  <P N="Guard" V="(GA-GB).NE.0" />
  <P N="Label" V="Geometry Drop = %d" T="Text" />
  <O T="Point" Y="GirderA_Horiz_Offset" Z="-TopWP_Vert_Offset+GB-CL" />
  <O T="Point" Y="GirderA_Horiz_Offset" Z="-TopWP_Vert_Offset+GA-CL" />
  <O T="Point" Y="GirderB_Horiz_Offset+20" Z="0" />
</O>
<!--
-->
</O>
<O N="Cross Frame Elev from 3D" T="CADDFrom3D" RX="PI/2" RZ="PI/2">
  <P N="Obj3D" V="Cross Frame" T="Group" />
</O>
<O N="Cross Frame Top from 3D" T="CADDFrom3D" RX="0" RZ="PI/2">
  <P N="Obj3D" V="Cross Frame" T="Group" />
</O>
</O>

```

**BoltedGusset**

BoltedGusset object is used for Cross Frame Gusset connection plates. The plate is defined as a surface with thickness. It contain bolt holes as cutout sub-surfaces. There are two nested Repeat objects that are used to create holes in both Y and Z direction of the plate. The outer repeat is along the Z axis (uses j control parameter) and the inner repeat is along Y axis (uses i control parameter).spY and spZ are the spacing along Y and Z axis, respectively. (locY, locZ) is the location of the hole.

open BrIM BoltedGusset BY MIKE BARTHLOMEW

Refresh

Plate Dimensions ▾

W width of the plate	h height of the plate	t_g thickness of the plate
15	9.5	0.5
nROWS number of horizontal rows	nCOLS number of vertical columns	spY horizontal spacing between bolt holes
3	2	3
spZ vertical spacing between bolt holes	d_b bolt diameter	C clearance from edge
2	0.75	1.75

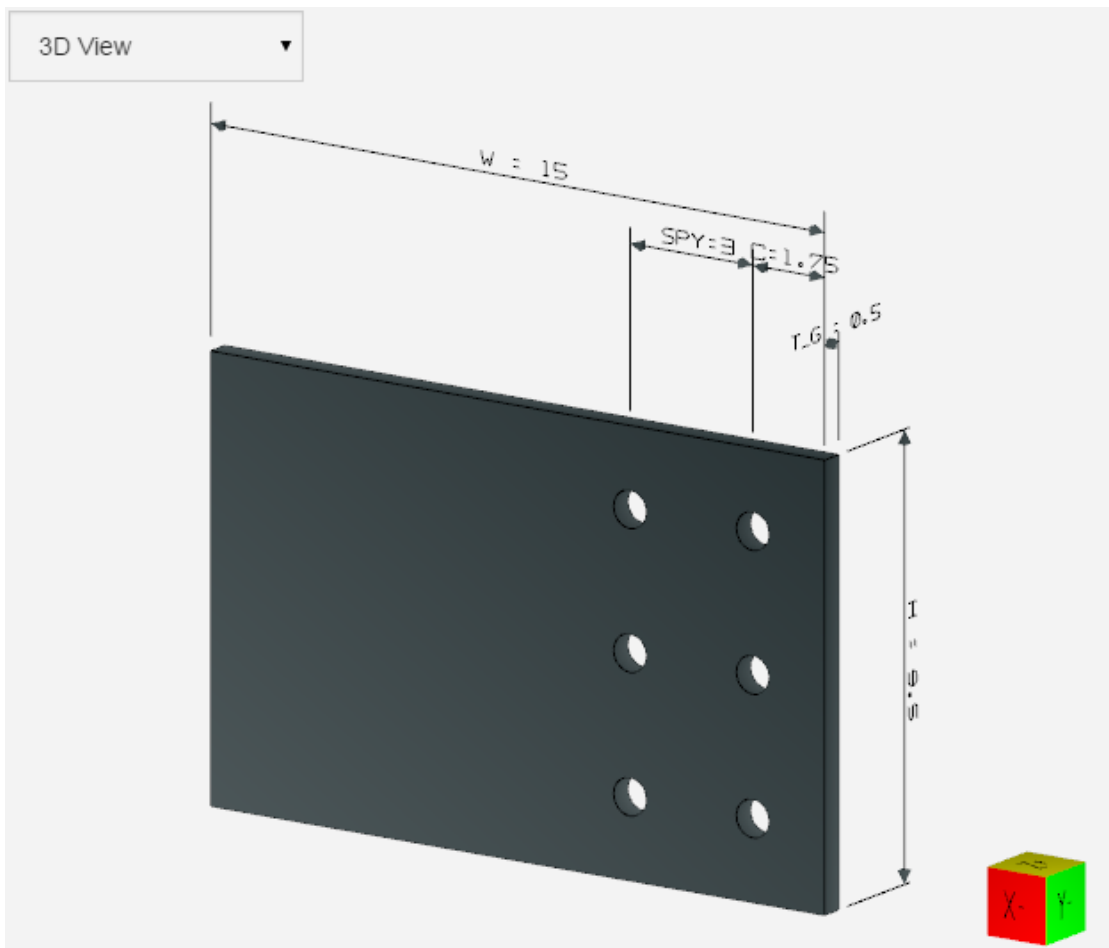

ParamML Code

```

<O N="BoltedGusset" T="Project">
  <!-- created by Mike Bartholomew on 7/9/2015 -->
  <O N="ObjDesc" T="Group">
    <!--
<p> |BoltedGusset| object is used for Cross Frame Gusset connection plates.
The plate is defined as a surface with thickness. It contain bolt holes as cutout
sub-surfaces. There are two nested Repeat objects that are used to create
holes in both Y and Z direction of the plate. The outer repeat is along the
Z axis (uses j control parameter) and the inner repeat is along Y axis
(uses i control parameter).spY and spZ are the spacing along Y and Z axis,
respectively. (locY, locZ) is the location of the hole.
</p>
-->
  </O>
  <O N="Plate Dimensions" T="Group">
    <P N="w" V="15" D="width of the plate" Role="Input" Category="Plate Dimensions" />
    <P N="h" V="9.5" D="height of the plate" Role="Input" Category="Plate Dimensions" />
    <P N="t_g" V="0.5" D="thickness of the plate" Role="Input" Category="Plate Dimensions" />
    <P N="nrows" V="3" D="number of horizontal rows" Role="Input" Category="Plate Dimensions" />
    <P N="ncols" V="2" D="number of vertical columns" Role="Input" Category="Plate Dimensions" />
    <P N="spY" V="3" D="horizontal spacing between bolt holes" Role="Input" Category="Plate Dimensions" />
    <P N="spZ" V="3" D="vertical spacing between bolt holes " Role="Input" Category="Plate Dimensions" />
    <P N="d_b" V="0.75" D="bolt diameter" Role="Input" Category="Plate Dimensions" />
    <P N="c" V="1.75" D="clearance from edge" Role="Input" Category="Plate Dimensions" />
  </O>
  <O N="Plate" T="Group">
    <O T="Surface">
      <P N="Thickness" V="t_g" />
      <P N="r" V="(d_b+1/16)/2" D="radius of bolt hole" />
      <O T="Point" Y="w/2" Z="-h/2" />
      <O T="Point" Y="-w/2" Z="-h/2" />
      <O T="Point" Y="-w/2" Z="h/2" />
      <O T="Point" Y="w/2" Z="h/2" />
      <O T="Repeat" S="0" I="1" E="nrows-1" CTRL="j" j="0">
        <O T="Repeat" S="0" I="1" E="ncols-1" CTRL="i" i="0">
          <P N="locY" V="-w/2 + c + spY * i" D="Y location of the bolt hole" />
          <P N="locZ" V="-h/2 + c + spZ * j" D="Z location of the bolt hole" />
          <O T="Circle" Y="locY" Z="locZ" RY="PI/2">
            <P N="IsCutout" V="1" />
            <P N="Radius" V="r" />
            <P N="Segments" V="20" />
          </O>
        </O>
      </O>
    </O>
  </O>
  <!--
Dimension lines for documentation
-->
  <O T="Private">
    <O N="Dimension Lines" T="Group">
      <P N="DimLineFontSize" V="w / 50" />
      <P N="DimLineArrowSize" V="w / 50" />
      <P N="DimLineMargin" V="w / 50" />
    </O>
  </O>

```

```

<O T="DimensionLine" FontSize="DimLineFontSize" ArrowSize="DimLineArrowSize" AlignH="Warp"
AlignT="None" AlignV="Warp">
  <P N="Label" V=" w = |d|" T="Text" />
  <O T="Point" Y="w/2" X="-t_g" Z="h/2 + DimLineMargin" />
  <O T="Point" Y="-w/2" X="-t_g" Z="h/2 + DimLineMargin" />
  <O T="Point" Y="0" X="-t_g" Z="h" />
</O>
<O T="DimensionLine" FontSize="DimLineFontSize" ArrowSize="DimLineArrowSize" AlignH="Warp"
AlignT="None" AlignV="Warp">
  <P N="Label" V=" c=|d|" T="Text" />
  <O T="Point" Y="w/2 - c" X="-t_g" Z="h/2 + DimLineMargin" />
  <O T="Point" Y="w/2" X="-t_g" Z="h/2 + DimLineMargin" />
  <O T="Point" Y="0" X="-t_g" Z="0.9*h" />
</O>
<O T="DimensionLine" FontSize="DimLineFontSize" ArrowSize="DimLineArrowSize" AlignH="Warp"
AlignT="None" AlignV="Warp">
  <P N="Label" V=" spY=|d|" T="Text" />
  <O T="Point" Y="w/2 - c - spY" X="-t_g" Z="h/2 + DimLineMargin" />
  <O T="Point" Y="w/2 - c" X="-t_g" Z="h/2 + DimLineMargin" />
  <O T="Point" Y="0" X="-t_g" Z="0.9*h" />
</O>
<O T="DimensionLine" FontSize="DimLineFontSize" ArrowSize="DimLineArrowSize" AlignH="Warp"
AlignT="None" AlignV="Warp">
  <P N="Label" V=" h = |d|" T="Text" />
  <O T="Point" Y="w/2" X="DimLineMargin" Z="h/2" />
  <O T="Point" Y="w/2" X="DimLineMargin" Z="-h/2" />
  <O T="Point" Y="w/2" X="h/4" Z="0" />
</O>
<O T="DimensionLine" FontSize="DimLineFontSize" ArrowSize="DimLineArrowSize" AlignH="Warp"
AlignT="None" AlignV="Warp">
  <P N="Label" V=" t_g = |d|" T="Text" />
  <O T="Point" Y="w/2" X="-t_g" Z="h/2 + DimLineMargin" />
  <O T="Point" Y="w/2" X="0" Z="h/2 + DimLineMargin" />
  <O T="Point" Y="w/2" X="-t_g/2" Z="0.75*h" />
</O>
<!--
<O T="DimensionLine" FontSize="DimLineFontSize" ArrowSize="DimLineArrowSize" AlignH="Warp"
AlignT="None" AlignV="Warp">
  <P N="Label" V=" w = |d|" T="Text" />
  <O T="Point" Y="-w/2" X="DimLineMargin" Z="h/2" />
  <O T="Point" Y="w/2" X="DimLineMargin" Z="h/2" />
  <O T="Point" Y="0" X="h/2" Z="h/2" />
</O>
<O T="DimensionLine" FontSize="DimLineFontSize" ArrowSize="DimLineArrowSize" AlignH="Warp"
AlignT="None" AlignV="Warp">
  <P N="Label" V=" t_g = |d|" T="Text" />
  <O T="Point" Y="w/2 + DimLineMargin" X="0" Z="0" />
  <O T="Point" Y="w/2 + DimLineMargin" X="-t_g" Z="0" />
  <O T="Point" Y="w" X="-t_g/2" Z="0" />
</O>
-->
<O N="Elevation" T="CADDFrom3D" RX="PI/2" RY="0" RZ="PI/2">
  <P N="Obj3D" V="Plate" T="Group" />
</O>
<O N="Vertical Section" T="CADDFrom3D" RX="PI/2" RY="0" RZ="PI">
  <P N="Obj3D" V="Plate" T="Group" />

```

```
</O>  
<O N="Horizontal Section" T="CADDFrom3D" RX="0" RY="0" RZ="PI/2">  
  <P N="Obj3D" V="Plate" T="Group" />  
</O>  
</O>  
</O>  
</O>  
</O>
```

## **WeldedGusset**

WeldedGusset object is used for Cross Frame Gusset connection plates. The plate is defined as a surface with thickness, and is intended for fully shop welded connections.

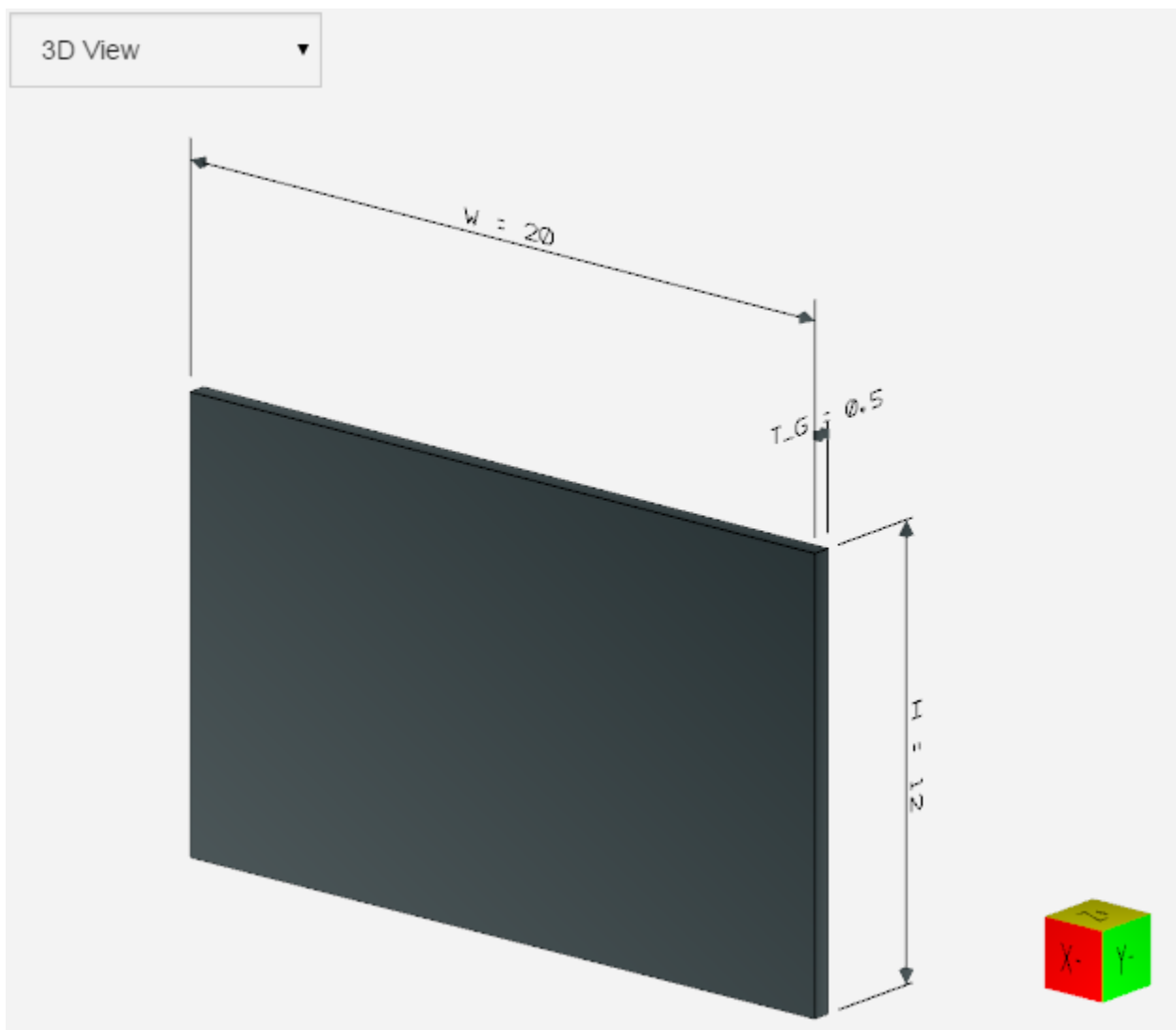



ParamML Code

```

<O N="WeldedGusset" T="Project">
  <O N="ObjDesc" T="Group">
    <!--
  <p> |WeldedGusset| object is used for Cross Frame Gusset connection plates.
  The plate is defined as a surface with thickness, and is intended for fully
  shop welded connections.
  </p>
  -->
  </O>
  <!-- created by Mike Bartholomew on 7/20/2015 -->
  <O N="Plate Dimensions" T="Group">
    <P N="w" V="20" D="width of the plate" Role="Input" Category="Plate Dimensions" />
    <P N="h" V="12" D="height of the plate" Role="Input" Category="Plate Dimensions" />
    <P N="t_g" V="0.5" D="thickness of the plate" Role="Input" Category="Plate Dimensions" />
  </O>
  <!--
  The plate will be a a surface with thickness.
  -->
  <O N="Plate" T="Group">
    <O T="Surface" RX="0" RY="0">
      <P N="Thickness" V="t_g" />
      <O T="Point" Y="w/2" Z="-h/2" />
      <O T="Point" Y="-w/2" Z="-h/2" />
      <O T="Point" Y="-w/2" Z="h/2" />
      <O T="Point" Y="w/2" Z="h/2" />
    </O>
    <!--
    Dimension lines for documentation
    -->
    <O T="Private">
      <O N="Dimension Lines" T="Group">
        <P N="DimLineFontSize" V="w / 50" />
        <P N="DimLineArrowSize" V="w / 50" />
        <P N="DimLineMargin" V="w / 50" />
        <O T="DimensionLine" FontSize="DimLineFontSize" ArrowSize="DimLineArrowSize" AlignH="Warp"
        AlignT="None" AlignV="Warp">
          <P N="Label" V=" w = |d|" T="Text" />
          <O T="Point" Y="w/2" X="-t_g" Z="h/2 + DimLineMargin" />
          <O T="Point" Y="-w/2" X="-t_g" Z="h/2 + DimLineMargin" />
          <O T="Point" Y="0" X="-t_g" Z="h" />
        </O>
        <O T="DimensionLine" FontSize="DimLineFontSize" ArrowSize="DimLineArrowSize" AlignH="Warp"
        AlignT="None" AlignV="Warp">
          <P N="Label" V=" h = |d|" T="Text" />
          <O T="Point" Y="w/2" X="DimLineMargin" Z="h/2" />
          <O T="Point" Y="w/2" X="DimLineMargin" Z="-h/2" />
          <O T="Point" Y="w/2" X="h/4" Z="0" />
        </O>
        <O T="DimensionLine" FontSize="DimLineFontSize" ArrowSize="DimLineArrowSize" AlignH="Warp"
        AlignT="None" AlignV="Warp">
          <P N="Label" V=" t_g = |d|" T="Text" />
          <O T="Point" Y="w/2" X="-t_g" Z="h/2 + DimLineMargin" />
          <O T="Point" Y="w/2" X="0" Z="h/2 + DimLineMargin" />
          <O T="Point" Y="w/2" X="-t_g/2" Z="0.75*h" />

```

```
</O>  
<O N="Elevation" T="CADDFrom3D" RX="PI/2" RY="0" RZ="PI/2">  
  <P N="Obj3D" V="Plate" T="Group" />  
</O>  
<O N="Vertical Section" T="CADDFrom3D" RX="PI/2" RY="0" RZ="PI">  
  <P N="Obj3D" V="Plate" T="Group" />  
</O>  
<O N="Horizontal Section" T="CADDFrom3D" RX="0" RY="0" RZ="PI/2">  
  <P N="Obj3D" V="Plate" T="Group" />  
</O>  
</O>  
</O>  
</O>  
</O>
```

## CrossFrameLayout

CrossFrameLayout uses the Repeat object to generate multiple cross frames along a bridge at locations determined by the array parameter CrossFrameLocations.

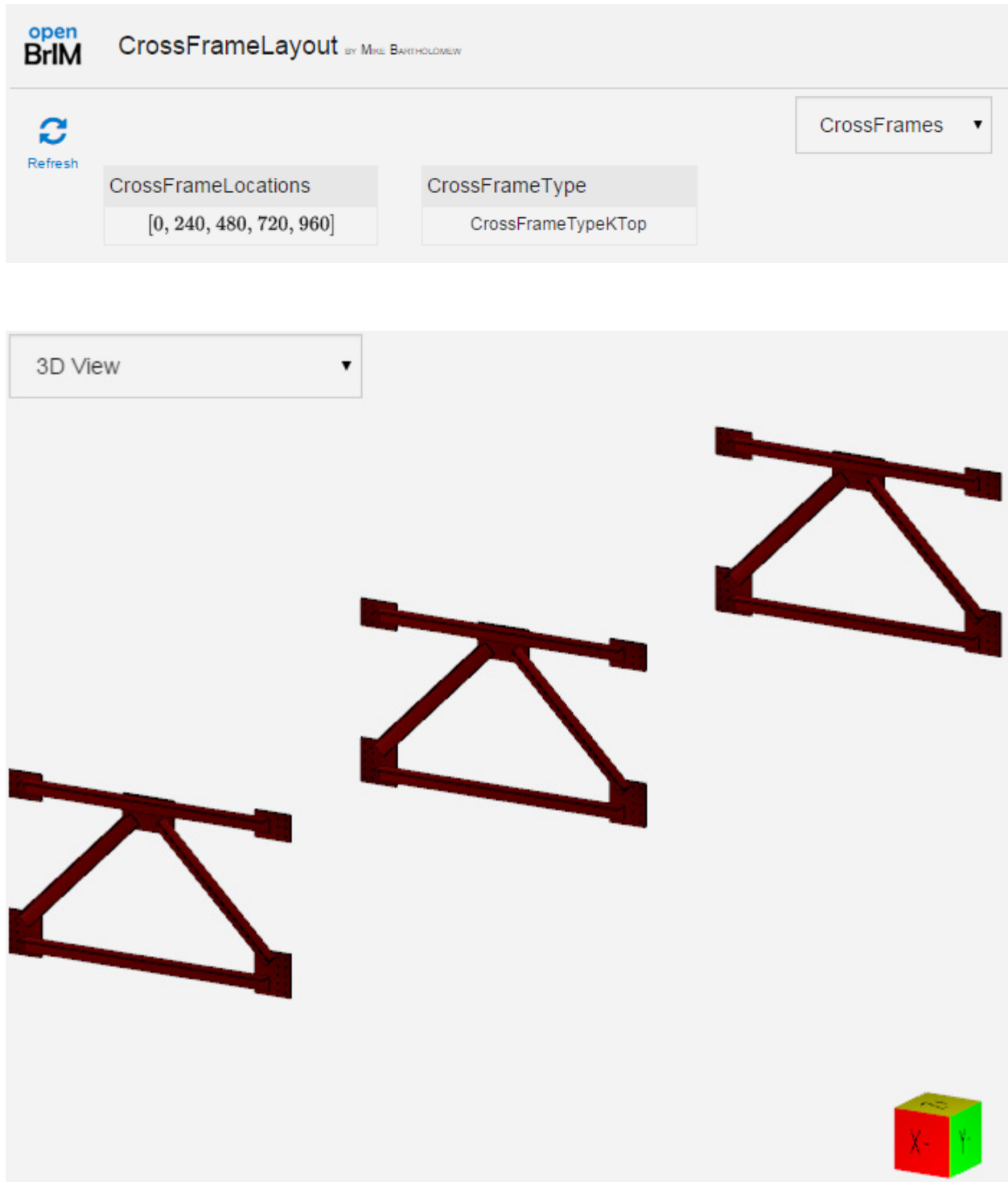

ParamML Code

```

<O N="CrossFrameLayout" T="Project">
  <!-- created by Mike Bartholomew on 8/16/2015 -->
  <O N="CrossFrames" T="Group">
    <P N="CrossFrameDesignation" V="CF1" T="Text" />
    <P N="CrossFrameLocations" V="[0,240,480,720,960]" Role="Input" Category="CrossFrames" />
    <P N="CrossFrameType" V="CrossFrameTypeKTop" T="Text" Role="Input" Category="CrossFrames" />
    <P N="StartStation" V="0" />
    <O T="Repeat">
      <P N="S" V="0" />
      <P N="E" V="length(CrossFrameLocations)-1" />
      <P N="I" V="1" />
      <P N="CTRL" V="spi" T="Text" />
      <P N="spi" V="0" />
      <O T="CrossFrameTypeKTop" Z="-12.5" X="-(ConnStiffT+thickness)/2+CrossFrameLocations[spi]">
        <P N="XFStation" V="StartStation+CrossFrameLocations[spi]" />
        <P N="GirderA_Horiz_Offset" V="-57" D="Girder A (Left) CL Offset from HCL" />
        <P N="GirderB_Horiz_Offset" V="57" D="Girder B (Right) CL Offset from HCL" />
        <P N="TopWP_Vert_Offset" V="5" D="Top Work Point offset from top of Girder web" />
        <P N="TopWP_Horiz_Offset" V="0" D="Top Work Point offset from CL of Girder web" />
        <P N="BotWP_Vert_Offset" V="5" D="Bottom Work Point offset from bottom of Girder web" />
        <P N="BotWP_Horiz_Offset" V="0" D="Bottom Work Point offset from CL of Girder web" />
        <P N="WebDepth" V="66" />
        <P N="WebCLtoGusset" V="1" />
        <P N="BoltDia" V="0.75" D="Diameter of bolt" />
        <P N="EdgeDist" V="1.75" D="Distance from edge of Plate to CL of Bolt Hole" />
        <P N="ConnStiffT" V="0.75" D="Connector Stiffener Thickness" />
      <O N="DefaultSection" T="Section">
        <P N="t" V="0.5" />
        <P N="b" V="5" />
        <P N="d" V="5" />
        <P N="x" V="1.4375" D="CG about X-axis" />
        <P N="y" V="1.4375" D="CG about Y-axis" />
        <O T="Shape">
          <O T="Point" X="0" Y="0" />
          <O T="Point" X="b" Y="0" />
          <O T="Point" X="b" Y="t" />
          <O T="Point" X="t" Y="t" />
          <O T="Point" X="t" Y="d" />
          <O T="Point" X="0" Y="d" />
        </O>
      </O>
    </O>
  <O N="Cross Frame Member Data" T="Group">
    <P N="TopChord" V="DefaultSection" T="Section" />
    <P N="BotChord" V="DefaultSection" T="Section" />
    <P N="Diagonal" V="DefaultSection" T="Section" />
  </O>
  <O N="Gusset Plate Data" T="Group">
    <P N="TopGusset_H" V="14" />
    <P N="TopGusset_V" V="9.5" />
    <P N="TopBoltGroupCols" V="2" D="number of cols" />
    <P N="TopBoltGroupRows" V="3" D="number of rows" />
    <P N="TopBoltGroupSpY" V="3" D="Horiz spacing between columns" />
    <P N="TopBoltGroupSpZ" V="3" D="Vert spacing between rows" />
    <P N="BottomGusset_H" V="14" />
  </O>

```

```
<P N="BottomGusset_V" V="15.5" />  
<P N="BottomBoltGroupCols" V="2" D="number of cols" />  
<P N="BottomBoltGroupRows" V="5" D="number of rows" />  
<P N="BottomBoltGroupSpY" V="3" D="Horiz spacing between columns" />  
<P N="BottomBoltGroupSpZ" V="3" D="Vert spacing between rows" />  
<P N="CenterGusset_H" V="20" />  
<P N="CenterGusset_V" V="12" />  
<P N="thickness" V="0.5" D="thickness of the plate" />  
</O>  
</O>  
</O>  
</O>  
</O>
```

## Diaphragm

Diaphragm object is used for creating a steel girder type diaphragm. Diaphragms can be defined as a single object for the entire cross section of the bridge, or as individual sections between girders. The cross section is comprised of a web and top and bottom flange plates. The diaphragm also allows for inclusion of jacking stiffeners, fill plates, and splice plates.



### Diaphragm

BY BENJAMIN BLASEN

Diaphragm Section Data ▼

Refresh

<div style="border: 1px solid #ccc; padding: 5px; margin-bottom: 5px;"> <b>bc</b> Bottom Flange minimum clearance.  <div style="text-align: center; border: 1px solid #ccc; padding: 5px; width: 80px; margin: 0 auto;">3</div> </div>	<div style="border: 1px solid #ccc; padding: 5px; margin-bottom: 5px;"> <b>tc</b> Top Flange clearance.  <div style="text-align: center; border: 1px solid #ccc; padding: 5px; width: 80px; margin: 0 auto;">4</div> </div>	<div style="border: 1px solid #ccc; padding: 5px; margin-bottom: 5px;"> <b>tw</b> Web thickness  <div style="text-align: center; border: 1px solid #ccc; padding: 5px; width: 80px; margin: 0 auto;"><math>\frac{5}{8} = 0.625</math></div> </div>
<div style="border: 1px solid #ccc; padding: 5px; margin-bottom: 5px;"> <b>tfb</b> Width of the top flange  <div style="text-align: center; border: 1px solid #ccc; padding: 5px; width: 80px; margin: 0 auto;">10</div> </div>	<div style="border: 1px solid #ccc; padding: 5px; margin-bottom: 5px;"> <b>tft</b> Thickness of the top flange of the I girder  <div style="text-align: center; border: 1px solid #ccc; padding: 5px; width: 80px; margin: 0 auto;"><math>\frac{3}{4} = 0.75</math></div> </div>	<div style="border: 1px solid #ccc; padding: 5px; margin-bottom: 5px;"> <b>bfb</b> Width of the bottom flange of the I girder  <div style="text-align: center; border: 1px solid #ccc; padding: 5px; width: 80px; margin: 0 auto;">10</div> </div>
<div style="border: 1px solid #ccc; padding: 5px; margin-bottom: 5px;"> <b>bft</b> Thickness of the bottom flange of the I girder  <div style="text-align: center; border: 1px solid #ccc; padding: 5px; width: 80px; margin: 0 auto;"><math>\frac{3}{4} = 0.75</math></div> </div>	<div style="border: 1px solid #ccc; padding: 5px; margin-bottom: 5px;"> <b>gwpL</b> Girder Work Point Elevation, Left Side  <div style="text-align: center; border: 1px solid #ccc; padding: 5px; width: 80px; margin: 0 auto;">0</div> </div>	<div style="border: 1px solid #ccc; padding: 5px; margin-bottom: 5px;"> <b>gwpR</b> Girder Work Point Elevation, Right Side  <div style="text-align: center; border: 1px solid #ccc; padding: 5px; width: 80px; margin: 0 auto;">-9.12</div> </div>
<div style="border: 1px solid #ccc; padding: 5px; margin-bottom: 5px;"> <b>gd</b> Girder Depth  <div style="text-align: center; border: 1px solid #ccc; padding: 5px; width: 80px; margin: 0 auto;">66</div> </div>	<div style="border: 1px solid #ccc; padding: 5px; margin-bottom: 5px;"> <b>bsw</b> Bearing Stiffener Width  <div style="text-align: center; border: 1px solid #ccc; padding: 5px; width: 80px; margin: 0 auto;">7.5</div> </div>	<div style="border: 1px solid #ccc; padding: 5px; margin-bottom: 5px;"> <b>gap</b> Gap between bearing stiffener and diaphragm.  <div style="text-align: center; border: 1px solid #ccc; padding: 5px; width: 80px; margin: 0 auto;">0.5</div> </div>
<div style="border: 1px solid #ccc; padding: 5px; margin-bottom: 5px;"> <b>fpt</b> Fill Plate Thickness  <div style="text-align: center; border: 1px solid #ccc; padding: 5px; width: 80px; margin: 0 auto;"><math>\frac{1}{16} = 0.0625</math></div> </div>	<div style="border: 1px solid #ccc; padding: 5px; margin-bottom: 5px;"> <b>fpb</b> Fill Plate Width  <div style="text-align: center; border: 1px solid #ccc; padding: 5px; width: 80px; margin: 0 auto;">6.5</div> </div>	<div style="border: 1px solid #ccc; padding: 5px; margin-bottom: 5px;"> <b>spt</b> Splice Plate Thickness  <div style="text-align: center; border: 1px solid #ccc; padding: 5px; width: 80px; margin: 0 auto;"><math>\frac{3}{8} = 0.375</math></div> </div>
<div style="border: 1px solid #ccc; padding: 5px; margin-bottom: 5px;"> <b>spb</b> Splice Plate Width  <div style="text-align: center; border: 1px solid #ccc; padding: 5px; width: 80px; margin: 0 auto;">13.5</div> </div>	<div style="border: 1px solid #ccc; padding: 5px; margin-bottom: 5px;"> <b>nR</b> Number of Bolt Hole Rows  <div style="text-align: center; border: 1px solid #ccc; padding: 5px; width: 80px; margin: 0 auto;">11</div> </div>	<div style="border: 1px solid #ccc; padding: 5px; margin-bottom: 5px;"> <b>nC</b> Number of Bolt Hole Columns  <div style="text-align: center; border: 1px solid #ccc; padding: 5px; width: 80px; margin: 0 auto;">4</div> </div>
<div style="border: 1px solid #ccc; padding: 5px; margin-bottom: 5px;"> <b>spc</b> Splice Plate Clearance  <div style="text-align: center; border: 1px solid #ccc; padding: 5px; width: 80px; margin: 0 auto;">2</div> </div>		

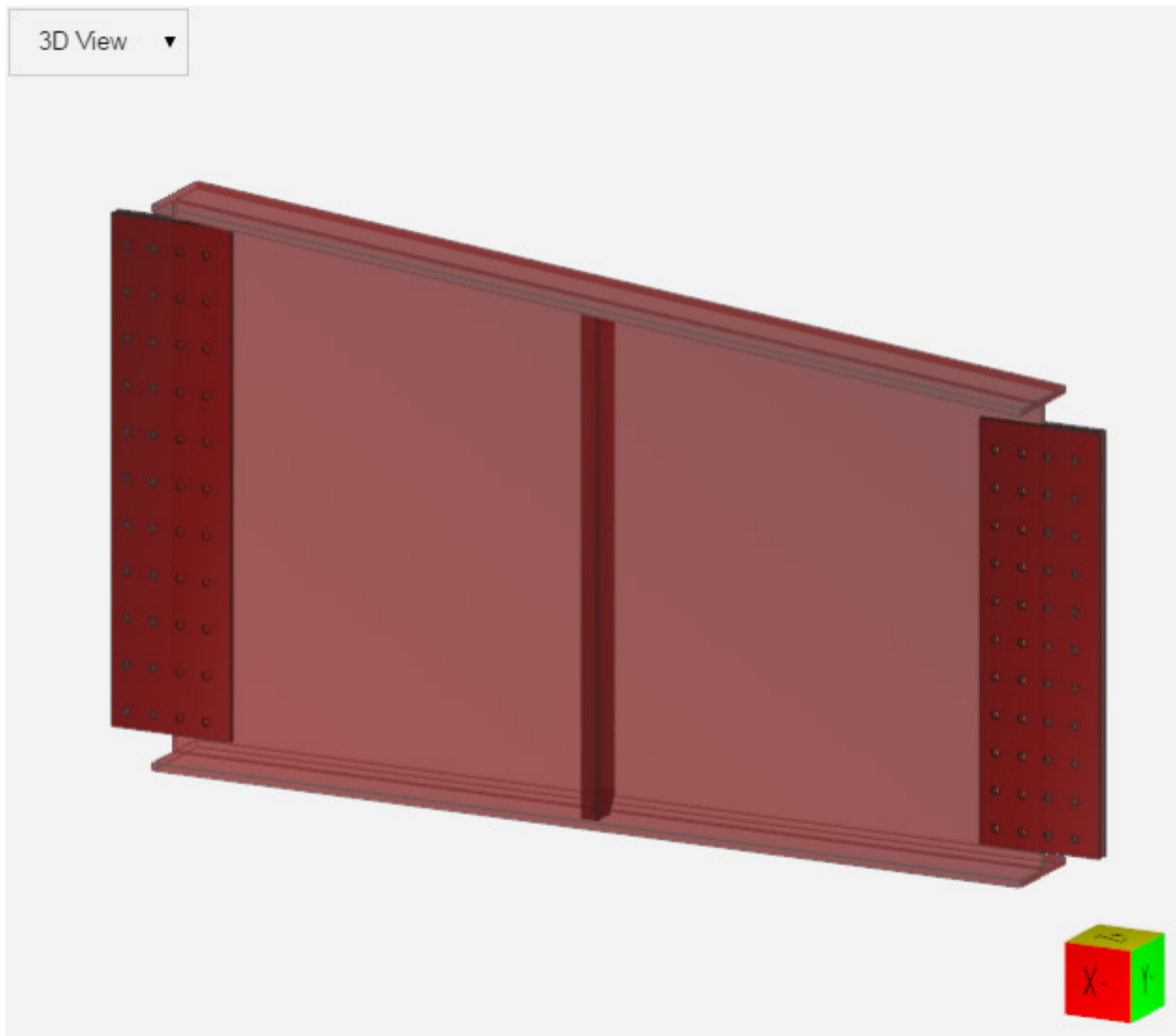

### ParamML Code

```

<O N="Diaphragm" T="Project">
  <P N="Color" V="#991111" T="Text" />
  <P N="Opacity" V="0.8" />
  <O N="ObjDesc" T="Group">
    <!--
    <p> |Diaphragm| object is used for creating a steel girder type diaphragm.
    Diaphragms can be defined as a single object for the entire cross section of the bridge,
    or as individual sections between girders. The cross section is comprised of a web and
    top and bottom flange plates. </p>
    </p> The diaphragm also allows for inclusion of jacking stiffeners, fill plates, and splice plates. </p>
    <p>
    <i>IN DEVELOPMENT..</i> bolt group code needs debugging and testing for proper placement in project files.
    <p>
    <i>created by <b>Benjamin Blasen</b> on 7/23/2015.</i>
    </p-->
  </O>
  <O N="Diaphragm Section Data" T="Group">

```

```

    <P N="Length" V="9*12+6" D="Length between CL of girders." />
    <P N="bc" V="3" D="Bottom Flange minimum clearance." Role="Input" Category="Diaphragm Section Data" />
    <P N="tc" V="4" D="Top Flange clearance." Role="Input" Category="Diaphragm Section Data" />
    <P N="tw" V="5/8" D="Web thickness " Role="Input" Category="Diaphragm Section Data" />
    <P N="tfb" V="10" D="Width of the top flange " Role="Input" Category="Diaphragm Section Data" />
    <P N="tft" V="3/4" D="Thickness of the top flange of the I girder" Role="Input" Category="Diaphragm Section
Data" />
    <P N="bfb" V="10" D="Width of the bottom flange of the I girder" Role="Input" Category="Diaphragm Section
Data" />
    <P N="bft" V="3/4" D="Thickness of the bottom flange of the I girder" Role="Input" Category="Diaphragm
Section Data" />
    <P N="gwpL" V="0" D="Girder Work Point Elevation, Left Side" Role="Input" Category="Diaphragm Section
Data" />
    <P N="gwpR" V="-9.12" D="Girder Work Point Elevation, Right Side" Role="Input" Category="Diaphragm
Section Data" />
    <P N="gd" V="66" D="Girder Depth" Role="Input" Category="Diaphragm Section Data" />
    <P N="bsw" V="7.5" D="Bearing Stiffener Width" Role="Input" Category="Diaphragm Section Data" />
    <P N="gap" V="0.5" D="Gap between bearing stiffener and diaphragm." Role="Input" Category="Diaphragm
Section Data" />
    <P N="fpt" V="1/16" D="Fill Plate Thickness" Role="Input" Category="Diaphragm Section Data" />
    <P N="fpb" V="6.5" D="Fill Plate Width" Role="Input" Category="Diaphragm Section Data" />
    <P N="spt" V="3/8" D="Splice Plate Thickness" Role="Input" Category="Diaphragm Section Data" />
    <P N="spb" V="13.5" D="Splice Plate Width" Role="Input" Category="Diaphragm Section Data" />
    <P N="nR" V="11" D="Number of Bolt Hole Rows " Role="Input" Category="Diaphragm Section Data" />
    <P N="nC" V="4" D="Number of Bolt Hole Columns " Role="Input" Category="Diaphragm Section Data" />
    <P N="spc" V="2" D="Splice Plate Clearance" Role="Input" Category="Diaphragm Section Data" />
    <P N="spH" V="3" D="Horiz spacing between columns" />
    <P N="spW" V="3" D="Center column space" />
    <P N="spV" V="5" D="Vert spacing between rows" />
    <P N="dia" V="7/8" D="Bolt Diameter" />
    <P N="edge" V="1.75" D="Distance from edge of Plate to CL of Bolt Hole" />
    <P N="JackingStiffOrient" V="B" T="Text" D="Side of Web stiffened, L = Left, R = Right, B = Both N = None" />
    <P N="JackingStiffT" V="1.75" D="Jacking Stiffener Thickness" />
    <P N="JackingStiffW" V="4" D="Jacking Stiffener Width" />
    <P N="JackingStiffHeight" V="gd-bc-tc-tft-bft" D="Jacking Stiffener Height" />
    <P N="JackingStiffClipH" V="1.5" D="Jacking Stiffener Horizontal Clip" />
    <P N="JackingStiffClipV" V="2.5" D="Jacking Stiffener Vertical Clip" />
    <P N="JackingStiffLoc" V="[Length/2]" D="Jacking Stiffener locations" />
    <!--
</O>
<O N="Stiffener and Plate Data" T="Group">
    <O N="Plate" T="Group">-->
    <!--
</O>
    <O N="JackingStiffener" T="Group">-->
    <!--</O>-->
</O>
<O N="Internal Drawing Parameters" T="Group">
    <P N="L" V="L" T="Text" D="Used for Left Side Stiffener only" />
    <P N="R" V="R" T="Text" D="Used for Right Side Stiffener only" />
    <P N="B" V="B" T="Text" D="Used for Both Sides Stiffener" />
</O>
<O N="DiaphragmGirder" T="Volume" RZ="PI">
    <P N="Material" V="STEEL" T="Material" D="Material" />
    <O N="IGirderL" T="Surface" X="0" Y="bsw+gap" Z="gwpL">
        <O T="Point" X="-tfb/2" Z="-tft-tc" />

```



```

<O T="Point" X="-tfb/2" Z="-tc" />
<O T="Point" X="tfb/2" Z="-tc" />
<O T="Point" X="tfb/2" Z="-tft-tc" />
<O T="Point" X="tw/2" Z="-tc-tft" />
<O T="Point" X="tw/2" Z="-gd+bc+bft" />
<O T="Point" X="bfb/2" Z="-gd+bc+bft" />
<O T="Point" X="bfb/2" Z="-gd+bc" />
<O T="Point" X="-bfb/2" Z="-gd+bc" />
<O T="Point" X="-bfb/2" Z="-gd+bc+bft" />
<O T="Point" X="tw/2" Z="-gd+bc+bft" />
<O T="Point" X="tw/2" Z="-tc-tft" />
</O>
<O N="IGirderR" T="Surface" X="0" Y="Length-bsw-gap" Z="gwpR">
  <O T="Point" X="-tfb/2" Z="-tft-tc" />
  <O T="Point" X="-tfb/2" Z="-tc" />
  <O T="Point" X="tfb/2" Z="-tc" />
  <O T="Point" X="tfb/2" Z="-tft-tc" />
  <O T="Point" X="tw/2" Z="-tc-tft" />
  <O T="Point" X="tw/2" Z="-gd+bc+bft+gwpL-gwpR" />
  <O T="Point" X="bfb/2" Z="-gd+bc+bft+gwpL-gwpR" />
  <O T="Point" X="bfb/2" Z="-gd+bc+gwpL-gwpR" />
  <O T="Point" X="-bfb/2" Z="-gd+bc+gwpL-gwpR" />
  <O T="Point" X="-bfb/2" Z="-gd+bc+bft+gwpL-gwpR" />
  <O T="Point" X="tw/2" Z="-gd+bc+bft+gwpL-gwpR" />
  <O T="Point" X="tw/2" Z="-tc-tft" />
</O>
</O>
<O N="FillPlates" T="Group" RZ="PI">
  <P N="Opacity" V="0.9" />
  <P N="spV" V="(gd-bc-tc-tft-bft-2*spc)/(nR)" D="Bolt Spacing" />
  <P N="spA" V="spV-(gwpL-gwpR)/(nR-1)" D="Bolt Spacing Adjustment" />
  <O N="Fill Plate Left Front" T="SplicePlate" X="tw/2" Y="bsw+gap+fpb/2" Z="gwpL-tc-tft-spc-(gd-bc-tc-tft-bft-2*spc)/2">
    <P N="w" V="fpb" D="width of the plate" />
    <P N="h" V="gd-bc-tc-tft-bft-2*spc" D="height of the plate" />
    <P N="t" V="-fpt" D="thickness of the plate" />
    <P N="nrows" V="nR" D="number of rows" />
    <P N="ncols" V="nC/2" D="number of columns" />
    <P N="spY" V="[spH]" D="Horiz spacing between columns" />
    <P N="spZ" V="[spV,spV,spV,spV,spV,spV,spV,spV,spV,spV]" D="Vert spacing between rows" />
    <P N="d" V="dia" D="Bolt Diameter" />
    <P N="c" V="edge" D="Distance from edge of Plate to CL of Bolt Hole" />
  </O>
  <O N="Fill Plate Left Back" T="SplicePlate" X="-tw/2" Y="bsw+gap+fpb/2" Z="gwpL-tc-tft-spc-(gd-bc-tc-tft-bft-2*spc)/2">
    <P N="w" V="fpb" D="width of the plate" />
    <P N="h" V="gd-bc-tc-tft-bft-2*spc" D="height of the plate" />
    <P N="t" V="-fpt" D="thickness of the plate" />
    <P N="nrows" V="nR" D="number of rows" />
    <P N="ncols" V="nC/2" D="number of columns" />
    <P N="spY" V="[spH]" D="Horiz spacing between columns" />
    <P N="spZ" V="[spV,spV,spV,spV,spV,spV,spV,spV,spV,spV]" D="Vert spacing between rows" />
    <P N="d" V="dia" D="Bolt Diameter" />
    <P N="c" V="edge" D="Distance from edge of Plate to CL of Bolt Hole" />
  </O>
</O>

```

```

<O N="Fill Plate Right Front" T="SplicePlate" X="tw/2" Y="Length-bsw-gap-fpb/2" Z="gwpR-tc-tft-spc-(gd-bc-tc-tft-bft-2*spc-(gwpL-gwpR))/2">
  <P N="w" V="fpb" D="width of the plate" />
  <P N="h" V="gd-bc-tc-tft-bft-2*spc-(gwpL-gwpR)" D="height of the plate" />
  <P N="t" V="-fpt" D="thickness of the plate" />
  <P N="nrows" V="nR" D="number of rows" />
  <P N="ncols" V="nC/2" D="number of columns" />
  <P N="spY" V="[spH]" D="Horiz spacing between columns" />
  <P N="spZ" V="[spA,spA,spA,spA,spA,spA,spA,spA,spA,spA,spA]" D="Vert spacing between rows" />
  <P N="d" V="dia" D="Bolt Diameter" />
  <P N="c" V="edge" D="Distance from edge of Plate to CL of Bolt Hole" />
</O>
<O N="Fill Plate Right Back" T="SplicePlate" X="-tw/2" Y="Length-bsw-gap-fpb/2" Z="gwpR-tc-tft-spc-(gd-bc-tc-tft-bft-2*spc-(gwpL-gwpR))/2">
  <P N="w" V="fpb" D="width of the plate" />
  <P N="h" V="gd-bc-tc-tft-bft-2*spc-(gwpL-gwpR)" D="height of the plate" />
  <P N="t" V="fpt" D="thickness of the plate" />
  <P N="nrows" V="nR" D="number of rows" />
  <P N="ncols" V="nC/2" D="number of columns" />
  <P N="spY" V="[spH]" D="Horiz spacing between columns" />
  <P N="spZ" V="[spA,spA,spA,spA,spA,spA,spA,spA,spA,spA,spA]" D="Vert spacing between rows" />
  <P N="d" V="dia" D="Bolt Diameter" />
  <P N="c" V="edge" D="Distance from edge of Plate to CL of Bolt Hole" />
</O>
</O>
<O N="SplicePlates" T="Group" RZ="PI">
  <P N="Opacity" V="0.9" />
  <P N="spV" V="(gd-bc-tc-tft-bft-2*spc)/(nR)" D="Bolt Spacing" />
  <P N="spA" V="spV-(gwpL-gwpR)/(nR-1)" D="Bolt Spacing Adjustment" />
  <O N="Splice Plate Left Front" T="SplicePlate" X="tw/2+fpt" Y="bsw+gap" Z="gwpL-tc-tft-spc-(gd-bc-tc-tft-bft-2*spc)/2">
    <P N="w" V="spb" D="width of the plate" />
    <P N="h" V="gd-bc-tc-tft-bft-2*spc" D="height of the plate" />
    <P N="t" V="-spt" D="thickness of the plate" />
    <P N="nrows" V="nR" D="number of rows" />
    <P N="ncols" V="nC" D="number of columns" />
    <P N="spY" V="[spH,spW,spH]" D="Horiz spacing between columns" />
    <P N="spZ" V="[spV,spV,spV,spV,spV,spV,spV,spV,spV,spV,spV]" D="Vert spacing between rows" />
    <P N="d" V="dia" D="Bolt Diameter" />
    <P N="c" V="edge" D="Distance from edge of Plate to CL of Bolt Hole" />
  </O>
  <O N="Splice Plate Left Back" T="SplicePlate" X="-tw/2-fpt" Y="bsw+gap" Z="gwpL-tc-tft-spc-(gd-bc-tc-tft-bft-2*spc)/2">
    <P N="w" V="spb" D="width of the plate" />
    <P N="h" V="gd-bc-tc-tft-bft-2*spc" D="height of the plate" />
    <P N="t" V="spt" D="thickness of the plate" />
    <P N="nrows" V="nR" D="number of rows" />
    <P N="ncols" V="nC" D="number of columns" />
    <P N="spY" V="[spH,spW,spH]" D="Horiz spacing between columns" />
    <P N="spZ" V="[spV,spV,spV,spV,spV,spV,spV,spV,spV,spV,spV]" D="Vert spacing between rows" />
    <P N="d" V="dia" D="Bolt Diameter" />
    <P N="c" V="edge" D="Distance from edge of Plate to CL of Bolt Hole" />
  </O>
  <O N="Splice Plate Right Front" T="SplicePlate" X="tw/2+fpt" Y="Length-bsw-gap" Z="gwpR-tc-tft-spc-(gd-bc-tc-tft-bft-2*spc-(gwpL-gwpR))/2">
    <P N="w" V="spb" D="width of the plate" />

```

```

<P N="h" V="gd-bc-tc-tft-bft-2*spc-(gwpl-gwpR)" D="height of the plate" />
<P N="t" V="-spt" D="thickness of the plate" />
<P N="nrows" V="nR" D="number of rows" />
<P N="ncols" V="nC" D="number of columns" />
<P N="spY" V="[spH,spW,spH]" D="Horiz spacing between columns" />
<P N="spZ" V="[spA,spA,spA,spA,spA,spA,spA,spA,spA,spA]" D="Vert spacing between rows" />
<P N="d" V="dia" D="Bolt Diameter" />
<P N="c" V="edge" D="Distance from edge of Plate to CL of Bolt Hole" />
</O>
<O N="Splice Plate Right Back" T="SplicePlate" X="tw/2-fpt" Y="Length-bsw-gap" Z="gwpR-tc-tft-spc-(gd-bc-tc-tft-bft-2*spc-(gwpl-gwpR))/2">
  <P N="w" V="spb" D="width of the plate" />
  <P N="h" V="gd-bc-tc-tft-bft-2*spc-(gwpl-gwpR)" D="height of the plate" />
  <P N="t" V="spt" D="thickness of the plate" />
  <P N="nrows" V="nR" D="number of rows" />
  <P N="ncols" V="nC" D="number of columns" />
  <P N="spY" V="[spH,spW,spH]" D="Horiz spacing between columns" />
  <P N="spZ" V="[spA,spA,spA,spA,spA,spA,spA,spA,spA,spA]" D="Vert spacing between rows" />
  <P N="d" V="dia" D="Bolt Diameter" />
  <P N="c" V="edge" D="Distance from edge of Plate to CL of Bolt Hole" />
</O>
</O>
<!--
<O N="Bolts Right" T="akBoltGroup" X="tw/2+fpt+spt" Y="bsw+gap+spb/2-spc" Z="gwpR-tc-tft-2*spc+dia/4"
RY="-PI/2" RZ="PI/2" AlignV="Orient" AlignH="Orient">
  <P N="Color" V="#ca2e2e" T="Text" />
  <P N="rows" V="nR" />
  <P N="cols" V="nC" />
  <P N="col_spacing" V="spH" />
  <P N="row_spacing" V="SplicePlates.spA" />
  <P N="thickness" V="tw+2*fpt+2*spt" D="distance between the inner surfaces of the nut and the head." />
  <P N="bolt_ds" V="dia" D="Diameter of the shaft of the bolt." />
  <P N="bolt_dh" V="1.4375" D="Diameter of the head of the bolt." />
  <P N="bolt_dn" V="1.4375" D="Diameter of the nut of the bolt." />
  <P N="bolt_th" V="15/32" D="Thickness of the head." />
  <P N="bolt_tn" V="46/64" D="Thickness of the nut." />
</O>
<O N="Bolts Left" T="akBoltGroup" X="tw/2+fpt+spt" Y="Length-bsw-gap+spb/2-spc" Z="gwpl-tc-tft-
2*spc+dia/4" RY="-PI/2" RZ="PI/2" AlignV="Orient" AlignH="Orient">
  <P N="Color" V="#ca2e2e" T="Text" />
  <P N="rows" V="nR" />
  <P N="cols" V="nC" />
  <P N="col_spacing" V="spH" />
  <P N="row_spacing" V="spV" />
  <P N="thickness" V="tw+2*fpt+2*spt" D="distance between the inner surfaces of the nut and the head." />
  <P N="bolt_ds" V="dia" D="Diameter of the shaft of the bolt." />
  <P N="bolt_dh" V="1.4375" D="Diameter of the head of the bolt." />
  <P N="bolt_dn" V="1.4375" D="Diameter of the nut of the bolt." />
  <P N="bolt_th" V="15/32" D="Thickness of the head." />
  <P N="bolt_tn" V="46/64" D="Thickness of the nut." />
</O-->
<!-- Draw Jacking Stiffeners
-->
<O T="Group" RZ="PI">
  <P N="Guard" V="JackingStiffOrient.NE.None" />
  <O T="Repeat" S="1" E="length(JackingStiffLoc)" I="1" CTRL="spi" spi="0">

```

```

<O N="Draw Right" T="Group">
  <P N="Guard" V="(JackingStiffOrient.EQ.R).OR.(JackingStiffOrient.EQ.B)" />
  <O T="VerticalStiffener" Y="JackingStiffLoc[spi-1]" X="tw/2" Z="-tc-
tft+((gwpL+gwpR)/Length)*JackingStiffLoc[spi-1]" RZ="PI/2">
    <P N="Opacity" V="0.9" />
    <P N="t" V="JackingStiffT" D="Thickness" />
    <P N="w" V="JackingStiffW" D="Width" />
    <P N="h" V="JackingStiffHeight-((gwpL-gwpR)/Length)*JackingStiffLoc[spi-1]" D="Height" />
    <P N="clipV" V="JackingStiffClipV" D="Vertical clip height" />
    <P N="clipH" V="JackingStiffClipH" D="Horizontal clip width" />
  </O>
</O>
<O N="Draw Left" T="Group">
  <P N="Guard" V="(JackingStiffOrient.EQ.L).OR.(JackingStiffOrient.EQ.B)" />
  <O T="VerticalStiffener" Y="JackingStiffLoc[spi-1]" X="-tw/2" Z="-tc-
tft+((gwpL+gwpR)/Length)*JackingStiffLoc[spi-1]" RZ="-PI/2">
    <P N="Opacity" V="0.9" />
    <P N="t" V="JackingStiffT" D="Thickness" />
    <P N="w" V="JackingStiffW" D="Width" />
    <P N="h" V="JackingStiffHeight-((gwpL-gwpR)/Length)*JackingStiffLoc[spi-1]" D="Height" />
    <P N="clipV" V="JackingStiffClipV" D="Vertical clip height" />
    <P N="clipH" V="JackingStiffClipH" D="Horizontal clip width" />
  </O>
</O>
</O>
</O>
</O>
</O>

```

**Deck**

Deck object is used for creating cast-in-place concrete bridge decks on girders. The cross section of the top of deck follows the alignment cross slope of the bridge, and the bottom of deck includes the build-up or haunches for the girders. The deck object also follows the horizontal alignment and vertical profile. Girder deck overhang options include constant thickness, or variable thickness from deck edge to the exterior girder haunch.

open BrIM Deck BY MIKE BARTHOLOMEW

Refresh

Deck Parameters

DeckWidth	436.5	MinDeck_t	8.5	TopDeckToTopGirderWeb	12.5
LeftDeck_t	10	RightDeck_t	10	LeftOverhangType	1
RightOverhangType	1	LeftEdge	272.25	GirderOffset	[117, 3, - 111, - 225]
HaunchWidth	[20, 20, 20, 22]				

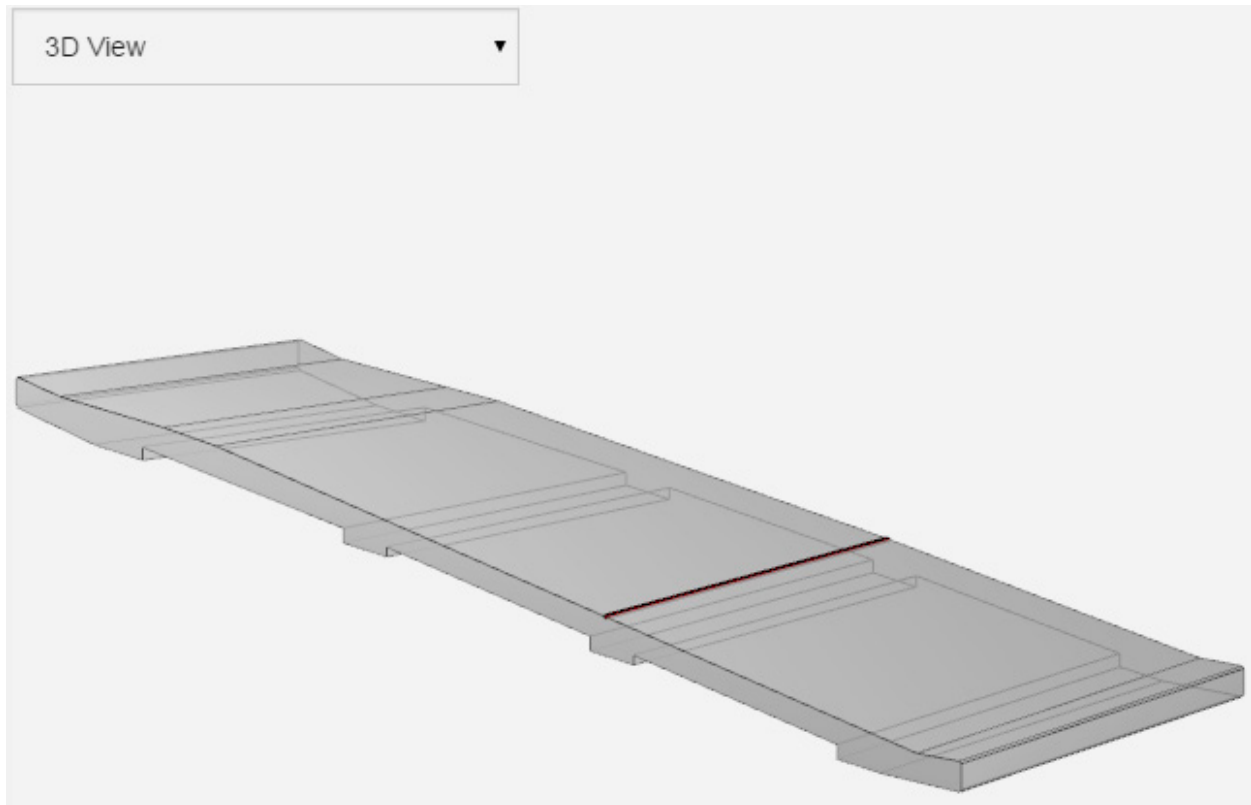

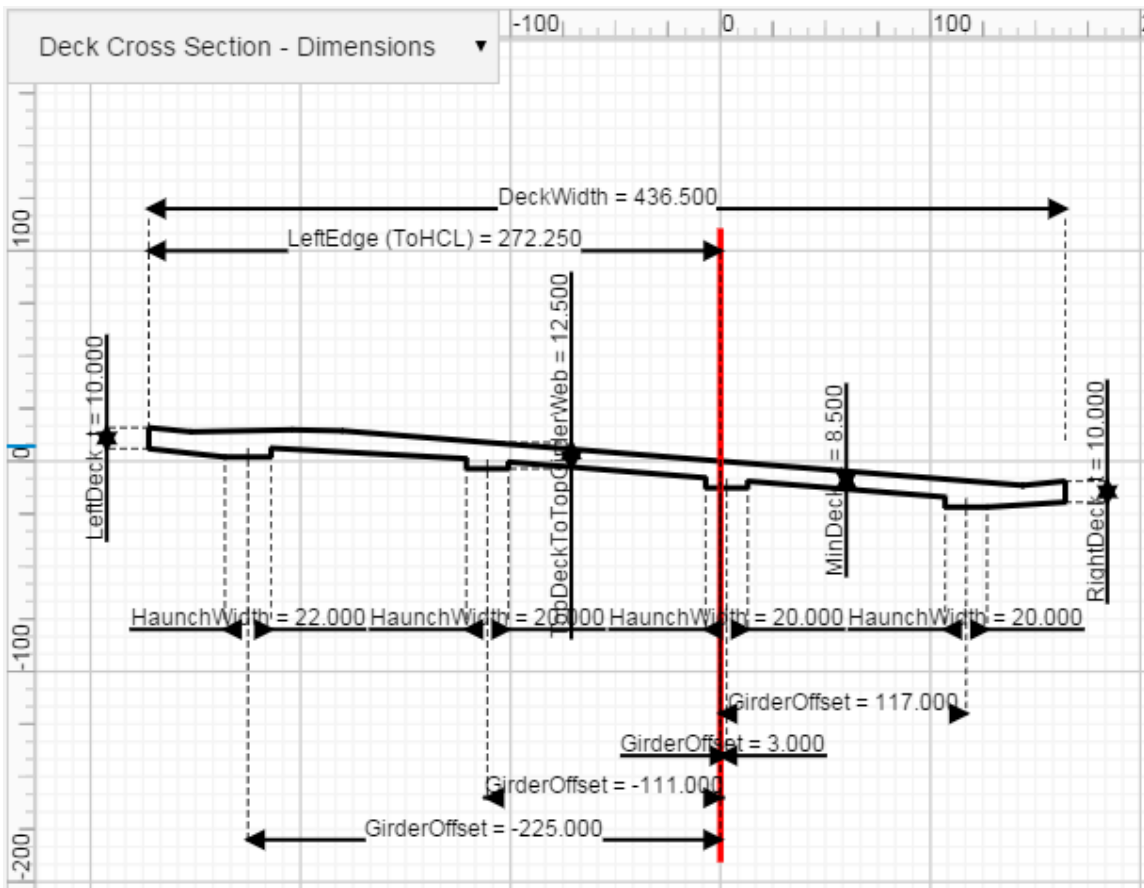

ParamML Code

```

<O N="Deck" T="Project">
  <P N="Alignment" V="CSAlignment" T="Alignment" />
  <O N="ObjDesc" T="Group">
    <!--
    <p> |Deck| object is used for creating cast-in-place concrete bridge decks on girders. The cross section
    of the top of deck follows the alignment cross slope of the bridge, and the bottom of deck includes the
    build-up or haunches for the girders. The deck object also follows the horizontal alignment and vertical
    profile. Girder deck overhang options include constant thickness, or variable thickness from deck edge to the
    exterior girder haunch. </p>
    -->
  </O>
  <O N="Deck Parameters" T="Group">
    <P N="StartStation" V="0" />
    <P N="EndStation" V="120" />
    <P N="DeckWidth" V="436.5" Role="Input" Category="Deck Parameters" />
    <P N="MinDeck_t" V="8.5" Role="Input" Category="Deck Parameters" />
    <P N="TopDeckToTopGirderWeb" V="12.5" Role="Input" Category="Deck Parameters" />
    <P N="LeftDeck_t" V="10" Role="Input" Category="Deck Parameters" />
    <P N="RightDeck_t" V="10" Role="Input" Category="Deck Parameters" />
    <P N="LeftOverhangType" V="1" Role="Input" Category="Deck Parameters" />
    <P N="RightOverhangType" V="1" Role="Input" Category="Deck Parameters" />
    <P N="LeftEdge" V="272.25" Role="Input" Category="Deck Parameters" />
    <P N="RightEdge" V="DeckWidth-LeftEdge" />
    <P N="GirderOffset" V="[117, 3, -111, -225]" Role="Input" Category="Deck Parameters" />
  </O>
</O>

```

```

    <P N="numGirders" V="length(GirderOffset)" />
    <P N="HaunchWidth" V="[20, 20, 20, 22]" Role="Input" Category="Deck Parameters" />
</O>
<!-- created by Mike Bartholomew on 7/14/2015 -->
<O N="Deck" T="Group">
    <O N="Deck Section" T="Volume" AlignH="Warp" AlignV="Warp" AlignT="Warp">
        <P N="Color" V="#D3D3D3" T="Text" />
        <P N="Opacity" V="0.8" />
        <P N="SegmentsAlong" V="100" />
        <P N="SegmentsAround" V="1" />
        <P N="DrawBorder" V="1" />
    <!--
-->
    <O N="Section1" T="Surface" X="StartStation">
        <O T="Point" C="0.75" Z="0" Y="RightEdge" />
        <O T="Point" C="0.75" Z="-RightDeck_t" Y="RightEdge" AlignTB="0" />
        <O T="Repeat" index="S" CTRL="index" I="1" E="numGirders-1" S="0">
            <P N="GA" V="alignT(CSAlignment, StartStation, GirderOffset[index]-0.5*HaunchWidth[index])" />
            <P N="CL" V="alignT(CSAlignment, StartStation, GirderOffset[index])" />
            <P N="GB" V="alignT(CSAlignment, StartStation, GirderOffset[index]+0.5*HaunchWidth[index])" />
            <P N="ElevCorrA" V="GA-CL" />
            <P N="ElevCorrB" V="GB-CL" />
            <O T="Point" Z="-MinDeck_t" Y="GirderOffset[index]+0.5*HaunchWidth[index]" AlignTB="0">
                <P N="Guard" V="(RightOverhangType.NE.1).OR.(index.NE.S)" />
            </O>
            <O T="Point" Z="-TopDeckToTopGirderWeb-ElevCorrB"
Y="GirderOffset[index]+0.5*HaunchWidth[index]" AlignTB="0" />
            <O T="Point" Z="-TopDeckToTopGirderWeb-ElevCorrA" Y="GirderOffset[index]-
0.5*HaunchWidth[index]" AlignTB="0" />
            <O T="Point" Z="-MinDeck_t" Y="GirderOffset[index]-0.5*HaunchWidth[index]" AlignTB="0">
                <P N="Guard" V="(LeftOverhangType.NE.1).OR.(index.NE.E)" />
            </O>
        </O>
        <O T="Point" C="0.75" Z="-LeftDeck_t" Y="-LeftEdge" AlignTB="0" />
        <O T="Point" C="0.75" Z="0" Y="-LeftEdge" />
    </O>
    <O T="Surface" X="EndStation">
        <O T="Point" C="0.75" Z="0" Y="RightEdge" />
        <O T="Point" C="0.75" Z="-RightDeck_t" Y="RightEdge" AlignTB="0" />
        <O T="Repeat" index="S" CTRL="index" I="1" E="numGirders-1" S="0">
            <P N="GA" V="alignT(CSAlignment, EndStation, GirderOffset[index]-0.5*HaunchWidth[index])" />
            <P N="CL" V="alignT(CSAlignment, EndStation, GirderOffset[index])" />
            <P N="GB" V="alignT(CSAlignment, EndStation, GirderOffset[index]+0.5*HaunchWidth[index])" />
            <P N="ElevCorrA" V="GA-CL" />
            <P N="ElevCorrB" V="GB-CL" />
            <O T="Point" Z="-MinDeck_t" Y="GirderOffset[index]+0.5*HaunchWidth[index]" AlignTB="0">
                <P N="Guard" V="(RightOverhangType.NE.1).OR.(index.NE.S)" />
            </O>
            <O T="Point" Z="-TopDeckToTopGirderWeb-ElevCorrB"
Y="GirderOffset[index]+0.5*HaunchWidth[index]" AlignTB="0" />
            <O T="Point" Z="-TopDeckToTopGirderWeb-ElevCorrA" Y="GirderOffset[index]-
0.5*HaunchWidth[index]" AlignTB="0" />
            <O T="Point" Z="-MinDeck_t" Y="GirderOffset[index]-0.5*HaunchWidth[index]" AlignTB="0">
                <P N="Guard" V="(LeftOverhangType.NE.1).OR.(index.NE.E)" />
            </O>
        </O>
    </O>

```

```

    <O T="Point" C="0.75" Z="-LeftDeck_t" Y="-LeftEdge" AlignTB="0" />
    <O T="Point" C="0.75" Z="0" Y="-LeftEdge" />
  </O>
</O>
<O T="Private">
  <O N="CSAlignment" T="Alignment">
    <P N="Station" V="0" />
    <P N="Azimuth" V="PI/2" />
    <O N="TangentSeg_1" T="Straight">
      <P N="Length" V="11700" />
    </O>
    <O N="Begin" T="ElevationPoint">
      <P N="Station" V="0" />
      <P N="Grade" V="0" />
      <P N="Elevation" V="0" />
    </O>
    <O N="Sta_6125" T="CrossSection">
      <P N="Station" V="0" />
      <P N="LeftEdgeToHCL" V="LeftEdge" />
      <P N="ElevationAtHCL" V="0" />
      <O N="LeftBarrier" T="CrossSectionSegment">
        <P N="Slope" V="-0.09876543" />
        <P N="Width" V="20.25" />
      </O>
      <O N="LeftShoulder" T="CrossSectionSegment">
        <P N="Slope" V="0.02" />
        <P N="Width" V="48" />
      </O>
      <O N="LeftShy" T="CrossSectionSegment">
        <P N="Slope" V="-0.02" />
        <P N="Width" V="24" />
      </O>
      <O N="Lane" T="CrossSectionSegment">
        <P N="Slope" V="-0.08" />
        <P N="Width" V="180" />
      </O>
      <O N="RightShoulder" T="CrossSectionSegment">
        <P N="Slope" V="-0.08" />
        <P N="Width" V="144" />
      </O>
      <O N="RightBarrier" T="CrossSectionSegment">
        <P N="Slope" V="0.09876543" />
        <P N="Width" V="20.25" />
      </O>
    </O>
    <O N="Sta_6588" T="CrossSection">
      <P N="Station" V="120" />
      <P N="LeftEdgeToHCL" V="272.25" />
      <P N="ElevationAtHCL" V="0" />
      <O N="LeftBarrier" T="CrossSectionSegment">
        <P N="Slope" V="-0.09876543" />
        <P N="Width" V="20.25" />
      </O>
      <O N="LeftShoulder" T="CrossSectionSegment">
        <P N="Slope" V="0.04" />

```



```

    <P N="Width" V="48" />
  </O>
  <O N="LeftShy" T="CrossSectionSegment">
    <P N="Slope" V="0.04" />
    <P N="Width" V="24" />
  </O>
  <O N="Lane" T="CrossSectionSegment">
    <P N="Slope" V="-0.02" />
    <P N="Width" V="180" />
  </O>
  <O N="RightShoulder" T="CrossSectionSegment">
    <P N="Slope" V="-0.04" />
    <P N="Width" V="144" />
  </O>
  <O N="RightBarrier" T="CrossSectionSegment">
    <P N="Slope" V="0.09876543" />
    <P N="Width" V="20.25" />
  </O>
</O>
</O>
</O>
<!--
  Horizontal Control Line is for debugging purposes only
-->
<O T="Private">
  <O N="Horizontal Control Line" T="Line">
    <P N="Alignment" V="CSAlignment" T="Alignment" />
    <P N="Color" V="#FF0000" T="Text" />
    <O N="Simple Line" T="Section">
      <P N="w" V="1" />
      <P N="h" V="1" />
      <O T="Shape">
        <O T="Point" X="-w/2" Y="-h/2" />
        <O T="Point" X="w/2" Y="-h/2" />
        <O T="Point" X="w/2" Y="h/2" />
        <O T="Point" X="-w/2" Y="h/2" />
      </O>
    </O>
    <O T="Point" X="StartStation" Z="0" Y="0" />
    <O T="Point" X="EndStation" Z="0" Y="0" />
  </O>
</O>
<!--
CADD Drawings
-->
<O N="Deck Cross Section - Dimensions" T="CADD" RX="PI/2" RZ="PI/2">
  <P N="w" V="[20.25, 48, 24, 180, 144, 20.25]" D="Cross Section Segment Widths" />
  <P N="numSectionWidths" V="length(w)" />
  <P N="margin" V="0.2" />
  <!--
  <P N="Slope" V="[-0.09876543, 0.02, -0.02, -0.08, -0.08, 0.09876543]" D="Cross Section Segment Slopes" />
-->
  <O T="CADDShape">
    <P N="Color" V="#000000" T="Text" />
    <P N="Thickness" V="3" />
    <P N="IsClosed" V="T" T="Text" />
  </O>

```

```

<!--
Girder Haunch Points (from right to left)
-->
<O T="Point" C="0.75" Z="alignT(CSAlignment, Station, RightEdge)" Y="RightEdge" />
<O T="Point" Z="alignT(CSAlignment, Station, RightEdge)-RightDeck_t" Y="RightEdge" AlignTB="0" />
<O T="Repeat" index="S" CTRL="index" I="1" E="numGirders-1" S="0">
  <P N="GB" V="alignT(CSAlignment, StartStation, GirderOffset[index]+0.5*HaunchWidth[index])" />
  <P N="CL" V="alignT(CSAlignment, StartStation, GirderOffset[index])" />
  <P N="GA" V="alignT(CSAlignment, StartStation, GirderOffset[index]-0.5*HaunchWidth[index])" />
  <O T="Point" Z="GB-MinDeck_t" Y="GirderOffset[index]+0.5*HaunchWidth[index]" AlignTB="0">
    <P N="Guard" V="(RightOverhangType.NE.1).OR.(index.NE.S)" />
  </O>
  <O T="Point" Z="CL-TopDeckToTopGirderWeb" Y="GirderOffset[index]+0.5*HaunchWidth[index]"
AlignTB="0" />
  <O T="Point" Z="CL-TopDeckToTopGirderWeb" Y="GirderOffset[index]-0.5*HaunchWidth[index]"
AlignTB="0" />
  <O T="Point" Z="GA-MinDeck_t" Y="GirderOffset[index]-0.5*HaunchWidth[index]" AlignTB="0">
    <P N="Guard" V="(LeftOverhangType.NE.1).OR.(index.NE.E)" />
  </O>
</O>
<O T="Point" Z="alignT(CSAlignment, Station, -LeftEdge)-LeftDeck_t" Y="-LeftEdge" AlignTB="0" />
<O T="Point" C="0.75" Z="alignT(CSAlignment, Station, -LeftEdge)" Y="-LeftEdge" />
<!--
Deck Break Points (from left to right)
-->
<O T="Point" C="0.75" Z="alignT(CSAlignment, Station, -LeftEdge+w[0])" Y="-LeftEdge+w[0]" />
<O T="Point" C="0.75" Z="alignT(CSAlignment, Station, -LeftEdge+w[0]+w[1])" Y="-LeftEdge+w[0]+w[1]" />
<O T="Point" C="0.75" Z="alignT(CSAlignment, Station, -LeftEdge+w[0]+w[1]+w[2])" Y="-
LeftEdge+w[0]+w[1]+w[2]" />
<O T="Point" C="0.75" Z="alignT(CSAlignment, Station, -LeftEdge+w[0]+w[1]+w[2]+w[3])" Y="-
LeftEdge+w[0]+w[1]+w[2]+w[3]" />
<O T="Point" C="0.75" Z="alignT(CSAlignment, Station, -LeftEdge+w[0]+w[1]+w[2]+w[3]+w[4])" Y="-
LeftEdge+w[0]+w[1]+w[2]+w[3]+w[4]" />
</O>
<O T="CADDLine">
  <P N="Color" V="#FF0000" T="Text" />
  <P N="Thickness" V="3" />
  <O T="Point" Y="0" Z="-110-numGirders*20" />
  <O T="Point" Y="0" Z="110" />
</O>
<O T="CADDDimensionLine">
  <P N="Label" V="LeftEdge (ToHCL) = %d" T="Text" />
  <O T="Point" Y="-LeftEdgeToHCL" Z="10" />
  <O T="Point" Y="0" Z="10" />
  <O T="Point" Y="0" Z="100" />
</O>
<O T="CADDDimensionLine">
  <P N="Label" V="DeckWidth = %d" T="Text" />
  <O T="Point" Y="-LeftEdgeToHCL" Z="10" />
  <O T="Point" Y="DeckWidth-LeftEdgeToHCL" Z="10" />
  <O T="Point" Y="0" Z="120" />
</O>
<O T="CADDDimensionLine">
  <P N="Label" V="MinDeck_t = %d" T="Text" />
  <O T="Point" Y="(GirderOffset[0]+GirderOffset[1])/2" Z="alignT(CSAlignment, Station,
(GirderOffset[0]+GirderOffset[1])/2)-MinDeck_t" />

```

```

    <O T="Point" Y="(GirderOffset[0]+GirderOffset[1])/2" Z="alignT(CSAlignment, Station,
(GirderOffset[0]+GirderOffset[1])/2)" />
    <O T="Point" Y="(GirderOffset[0]+GirderOffset[1])/2" Z="0" />
  </O>
  <O T="CADDDimensionLine">
    <P N="Label" V="TopDeckToTopGirderWeb = %d" T="Text" />
    <O T="Point" Y="GirderOffset[2]" Z="alignT(CSAlignment, Station, GirderOffset[2])-
TopDeckToTopGirderWeb" />
    <O T="Point" Y="GirderOffset[2]" Z="alignT(CSAlignment, Station, GirderOffset[2])" />
    <O T="Point" Y="GirderOffset[2]+40" Z="0" />
  </O>
  <O T="CADDDimensionLine">
    <P N="Label" V="LeftDeck_t = %d" T="Text" />
    <O T="Point" Y="-LeftEdge" Z="alignT(CSAlignment, Station, -LeftEdge)-LeftDeck_t" />
    <O T="Point" Y="-LeftEdge" Z="alignT(CSAlignment, Station, -LeftEdge)" />
    <O T="Point" Y="-LeftEdge-20" Z="0" />
  </O>
  <O T="CADDDimensionLine">
    <P N="Label" V="RightDeck_t = %d" T="Text" />
    <O T="Point" Y="RightEdge" Z="alignT(CSAlignment, Station, RightEdge)-RightDeck_t" />
    <O T="Point" Y="RightEdge" Z="alignT(CSAlignment, Station, RightEdge)" />
    <O T="Point" Y="RightEdge+20" Z="0" />
  </O>
  <O T="Repeat" index="S" CTRL="index" I="1" E="numGirders-1" S="0">
    <P N="CL" V="alignT(CSAlignment, StartStation, GirderOffset[index])" />
    <O T="CADDDimensionLine">
      <P N="Label" V="GirderOffset = %d" T="Text" />
      <P N="Guard" V="GirderOffset[index].GT.0" />
      <O T="Point" Y="0" Z="CL-MinDeck_t" />
      <O T="Point" Y="GirderOffset[index]" Z="CL-MinDeck_t" />
      <O T="Point" Y="0" Z="-120-index*20" />
    </O>
    <O T="CADDDimensionLine">
      <P N="Label" V="GirderOffset = -%d" T="Text" />
      <P N="Guard" V="GirderOffset[index].LT.0" />
      <O T="Point" Y="GirderOffset[index]" Z="CL-MinDeck_t" />
      <O T="Point" Y="0" Z="CL-MinDeck_t" />
      <O T="Point" Y="0" Z="-120-index*20" />
    </O>
    <O T="CADDDimensionLine">
      <P N="Label" V="HaunchWidth = %d" T="Text" />
      <O T="Point" Y="GirderOffset[index]-HaunchWidth[index]/2" Z="CL-TopDeckToTopGirderWeb-4" />
      <O T="Point" Y="GirderOffset[index]+HaunchWidth[index]/2" Z="CL-TopDeckToTopGirderWeb-4" />
      <O T="Point" Y="0" Z="-80" />
    </O>
  </O>
  <O N="Haunch Detail" T="CADD" RX="PI/2" RZ="PI/2">
    <P N="w" V="[20.25, 48, 24, 180, 144, 20.25]" D="Cross Section Segment Widths" />
    <P N="numSectionWidths" V="length(w)" />
    <P N="margin" V="0.2" />
    <!--
    <P N="Slope" V="[-0.09876543, 0.02, -0.02, -0.08, -0.08, 0.09876543]" D="Cross Section Segment Slopes" />
  -->
  <O T="CADDShape">
    <P N="Color" V="#000000" T="Text" />

```

```

<P N="Thickness" V="3" />
<P N="IsClosed" V="T" T="Text" />
<P N="GB" V="alignT(CSAlignment, StartStation, 0+0.5*HaunchWidth[1])" />
<P N="CL" V="alignT(CSAlignment, StartStation, 0)" />
<P N="GA" V="alignT(CSAlignment, StartStation, 0-0.5*HaunchWidth[1])" />
<O T="Point" Z="alignT(CSAlignment, Station, 30)" Y="30" />
<O T="Point" Z="alignT(CSAlignment, Station, 30)-MinDeck_t" Y="30" AlignTB="0" />
<O T="Point" Z="GB-MinDeck_t" Y="0+0.5*HaunchWidth[1]" AlignTB="0" />
<O T="Point" Z="CL-TopDeckToTopGirderWeb" Y="0+0.5*HaunchWidth[1]" AlignTB="0" />
<O T="Point" Z="CL-TopDeckToTopGirderWeb" Y="0-0.5*HaunchWidth[1]" AlignTB="0" />
<O T="Point" Z="GA-MinDeck_t" Y="0-0.5*HaunchWidth[1]" AlignTB="0" />
<O T="Point" Z="alignT(CSAlignment, Station, -30)-MinDeck_t" Y="-30" AlignTB="0" />
<O T="Point" Z="alignT(CSAlignment, Station, -30)" Y="-30" />
</O>
<O T="CADDLine">
  <P N="Color" V="#FF0000" T="Text" />
  <P N="Thickness" V="2" />
  <O T="Point" Y="0" Z="-30" />
  <O T="Point" Y="0" Z="5" />
</O>
<O T="CADDLine">
  <P N="Color" V="#0000FF" T="Text" />
  <P N="Thickness" V="2" />
  <O T="Point" Y="0.375" Z="-25" />
  <O T="Point" Y="0.375" Z="-TopDeckToTopGirderWeb" />
</O>
<O T="CADDLine">
  <P N="Color" V="#0000FF" T="Text" />
  <P N="Thickness" V="2" />
  <O T="Point" Y="-0.375" Z="-25" />
  <O T="Point" Y="-0.375" Z="-TopDeckToTopGirderWeb" />
</O>
<O T="CADDShape">
  <P N="Color" V="#0000FF" T="Text" />
  <P N="Thickness" V="2" />
  <P N="IsClosed" V="T" T="Text" />
  <O T="Point" Y="-HaunchWidth[1]/2" Z="-TopDeckToTopGirderWeb+1" />
  <O T="Point" Y="HaunchWidth[1]/2" Z="-TopDeckToTopGirderWeb+1" />
  <O T="Point" Y="HaunchWidth[1]/2" Z="-TopDeckToTopGirderWeb" />
  <O T="Point" Y="-HaunchWidth[1]/2" Z="-TopDeckToTopGirderWeb" />
</O>
<O T="CADDDimensionLine">
  <P N="Label" V="HaunchWidth = %d" T="Text" />
  <O T="Point" Y="-HaunchWidth[1]/2" Z="alignT(CSAlignment, Station, 0)-TopDeckToTopGirderWeb" />
  <O T="Point" Y="HaunchWidth[1]/2" Z="alignT(CSAlignment, Station, 0)-TopDeckToTopGirderWeb" />
  <O T="Point" Y="0" Z="-35" />
</O>
<O T="CADDDimensionLine">
  <P N="Label" V="MinDeck_t = %d" T="Text" />
  <O T="Point" Y="30" Z="alignT(CSAlignment, Station, 30)-MinDeck_t" />
  <O T="Point" Y="30" Z="alignT(CSAlignment, Station, 30)" />
  <O T="Point" Y="35" Z="0" />
</O>
<O T="CADDDimensionLine">
  <P N="Label" V="TopDeckToTopGirderWeb = %d" T="Text" />
  <O T="Point" Y="0" Z="alignT(CSAlignment, Station, 0)-TopDeckToTopGirderWeb" />

```

```
<O T="Point" Y="0" Z="alignT(CSAlignment, Station, 0)" />  
<O T="Point" Y="40" Z="0" />  
</O>  
</O>  
</O>
```

**DeckEndBeam**

DeckEndBeam object is used for creating the thickened end beam for cast-in-place concrete bridge decks on girders. The beam accounts for the slab bending at the free edge of deck, and accommodates an expansion joint blockout. The cross section of the top of deck follows the alignment cross slope of the bridge. The thickened section transitions to the typical deck cross section where the bottom of the deck includes the build-up or haunches for the girders.

open BrIM DeckEndBeam BY MIKE BARTHOLOMEW

Refresh

End Beam Parameters ▼

EndBeamCLStation	EndBeamPosition End Beam Position (0=Back Station, 1=Ahead Station)	EndBeamDepth
0	0	17.25
EndBeamDepthLeft	EndBeamDepthRight	EndBeamWidth
15.25	15.25	27.75
EndBeamOverhang	TransitionLength	TypDeckLength
16.75	8.75	6

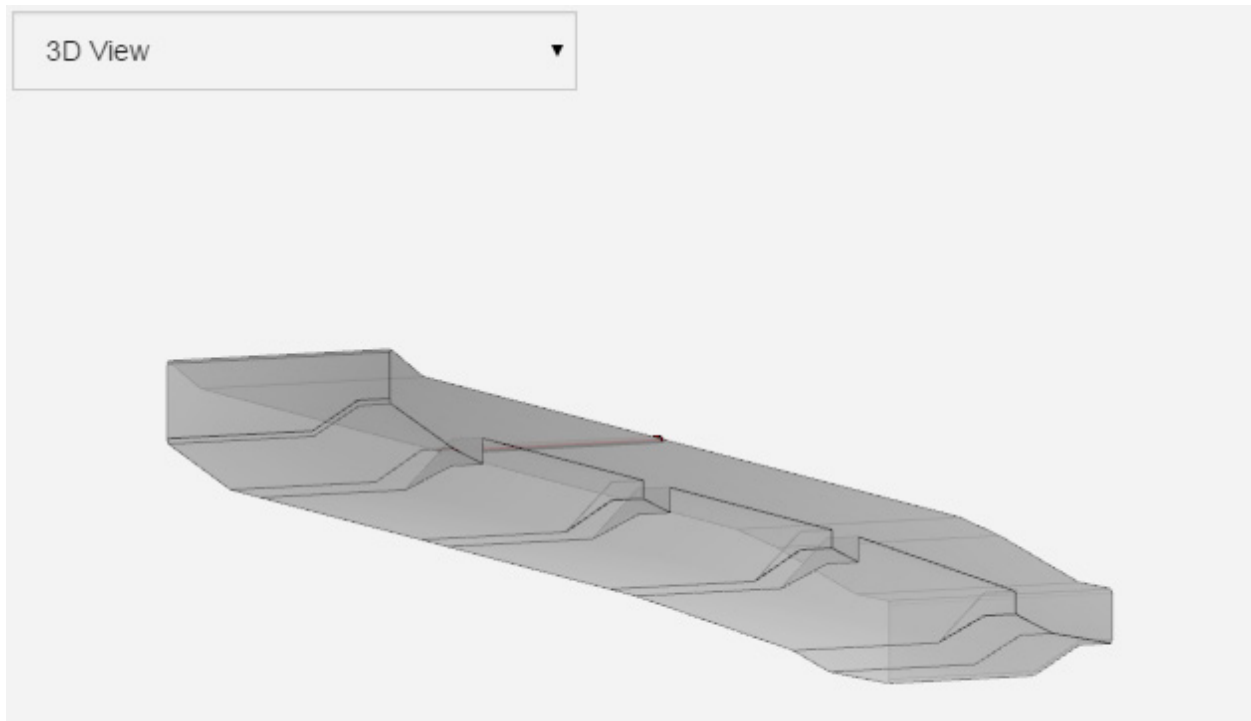

ParamML Code

```

<O N="DeckEndBeam" T="Project">
  <P N="Alignment" V="CSAlignment" T="Alignment" />
  <!-- created by Mike Bartholomew on 8/6/2015 -->
  <O N="ObjDesc" T="Group">
    <!--
<p> |DeckEndBeam| object is used for creating the thickened end beam for cast-in-place concrete bridge
decks on girders. The beam accounts for the slab bending at the free edge of deck, and accommodates an
expansion joint breakout. The cross section of the top of deck follows the alignment cross slope
of the bridge. The thickened section transitions to the typical deck cross section where the bottom of
the deck includes the build-up or haunches for the girders. </p>
-->
  </O>
  <O N="End Beam Parameters" T="Group">
    <P N="EndBeamCLStation" V="0" Role="Input" Category="End Beam Parameters" />
    <P N="EndBeamPosition" V="0" T="Text" D="End Beam Position (0=Back Station, 1=Ahead Station)"
Role="Input" Category="End Beam Parameters" />
    <P N="EndBeamDepth" V="17.25" Role="Input" Category="End Beam Parameters" />
    <P N="EndBeamDepthLeft" V="15.25" Role="Input" Category="End Beam Parameters" />
    <P N="EndBeamDepthRight" V="15.25" Role="Input" Category="End Beam Parameters" />
    <P N="EndBeamWidth" V="27.75" Role="Input" Category="End Beam Parameters" />
    <P N="EndBeamOverhang" V="16.75" Role="Input" Category="End Beam Parameters" />
    <P N="TransitionLength" V="8.75" Role="Input" Category="End Beam Parameters" />
    <P N="TypDeckLength" V="6" Role="Input" Category="End Beam Parameters" />
  </O>
  <O N="Deck Parameters" T="Group">
    <P N="DeckWidth" V="436.5" Role="Input" Category="Deck Parameters" />
    <P N="MinDeck_t" V="8.5" Role="Input" Category="Deck Parameters" />
    <P N="TopDeckToTopGirderWeb" V="12.5" Role="Input" Category="Deck Parameters" />
    <P N="LeftDeck_t" V="10" Role="Input" Category="Deck Parameters" />
    <P N="RightDeck_t" V="10" Role="Input" Category="Deck Parameters" />
    <P N="LeftOverhangType" V="1" Role="Input" Category="Deck Parameters" />
    <P N="RightOverhangType" V="1" Role="Input" Category="Deck Parameters" />
    <P N="LeftEdge" V="272.25" Role="Input" Category="Deck Parameters" />
    <P N="RightEdge" V="DeckWidth-LeftEdge" />
    <P N="GirderOffset" V="[117, 3, -111, -225]" Role="Input" Category="Deck Parameters" />
    <P N="numGirders" V="length(GirderOffset)" />
    <P N="HaunchWidth" V="[18, 16, 16, 22]" Role="Input" Category="Deck Parameters" />
    <!--
    <P N="StartStation" V="0" Role="Input" />
    <P N="EndStation" V="42.5" Role="Input" />
  -->
  <!--
-->
  </O>
  <O N="EndBeam" T="Group" AlignH="Warp" AlignV="Warp" AlignT="Warp">
    <P N="Color" V="#D3D3D3" T="Text" />
    <P N="Opacity" V="0.8" />
    <P N="SegmentsAlong" V="1" />
    <P N="SegmentsAround" V="1" />
    <P N="DrawBorder" V="1" />
    <O N="EndBeamBK" T="Volume">
      <P N="Guard" V="EndBeamPosition.EQ.0" />
      <P N="StartStation" V="EndBeamCLStation-EndBeamOverhang" />
      <P N="EndStation" V="StartStation+EndBeamWidth+TransitionLength+TypDeckLength" />
    </O>
  </O>

```

```

<!--
-->
<O N="Beam" T="Surface" X="StartStation">
  <O T="Point" C="0.75" Z="0" Y="RightEdge" />
  <O T="Point" C="0.75" Z="-EndBeamDepthRight" Y="RightEdge" AlignTB="0" />
  <O T="Repeat" index="S" CTRL="index" I="1" E="numGirders-1" S="0">
    <O T="Point" Z="-EndBeamDepth" Y="GirderOffset[index]+0.5*HaunchWidth[index]" AlignTB="0">
      <P N="Guard" V="(RightOverhangType.NE.1).OR.(index.NE.S)" />
    </O>
    <O T="Point" Z="-EndBeamDepth" Y="GirderOffset[index]+0.5*HaunchWidth[index]" AlignTB="0" />
    <O T="Point" Z="-EndBeamDepth" Y="GirderOffset[index]-0.5*HaunchWidth[index]" AlignTB="0" />
    <O T="Point" Z="-EndBeamDepth" Y="GirderOffset[index]-0.5*HaunchWidth[index]" AlignTB="0">
      <P N="Guard" V="(LeftOverhangType.NE.1).OR.(index.NE.E)" />
    </O>
  </O>
  <O T="Point" C="0.75" Z="-EndBeamDepthLeft" Y="-LeftEdge" AlignTB="0" />
  <O T="Point" C="0.75" Z="0" Y="-LeftEdge" />
</O>
<O T="Surface" Extends="Beam" X="StartStation+EndBeamWidth" />
<O N="TypDeck" T="Surface" X="StartStation+EndBeamWidth+TransitionLength">
  <O T="Point" C="0.75" Z="0" Y="RightEdge" />
  <O T="Point" C="0.75" Z="-RightDeck_t" Y="RightEdge" AlignTB="0" />
  <O T="Repeat" index="S" CTRL="index" I="1" E="numGirders-1" S="0">
    <P N="GA" V="alignT(CSAlignment, EndStation, GirderOffset[index]-0.5*HaunchWidth[index])" />
    <P N="CL" V="alignT(CSAlignment, EndStation, GirderOffset[index])" />
    <P N="GB" V="alignT(CSAlignment, EndStation, GirderOffset[index]+0.5*HaunchWidth[index])" />
    <P N="ElevCorrA" V="GA-CL" />
    <P N="ElevCorrB" V="GB-CL" />
    <O T="Point" Z="-MinDeck_t" Y="GirderOffset[index]+0.5*HaunchWidth[index]" AlignTB="0">
      <P N="Guard" V="(RightOverhangType.NE.1).OR.(index.NE.S)" />
    </O>
    <O T="Point" Z="-TopDeckToTopGirderWeb-ElevCorrB"
Y="GirderOffset[index]+0.5*HaunchWidth[index]" AlignTB="0" />
    <O T="Point" Z="-TopDeckToTopGirderWeb-ElevCorrA" Y="GirderOffset[index]-
0.5*HaunchWidth[index]" AlignTB="0" />
    <O T="Point" Z="-MinDeck_t" Y="GirderOffset[index]-0.5*HaunchWidth[index]" AlignTB="0">
      <P N="Guard" V="(LeftOverhangType.NE.1).OR.(index.NE.E)" />
    </O>
  </O>
  <O T="Point" C="0.75" Z="-LeftDeck_t" Y="-LeftEdge" AlignTB="0" />
  <O T="Point" C="0.75" Z="0" Y="-LeftEdge" />
</O>
<O T="Surface" Extends="TypDeck" X="EndStation" />
</O>
<!--

```

## Ahead Station End Beam

```

-->
<O N="EndBeamAH" T="Volume">
  <P N="Guard" V="EndBeamPosition.EQ.1" />
  <P N="EndStation" V="EndBeamCLStation+EndBeamOverhang" />
  <P N="StartStation" V="EndStation-EndBeamWidth-TransitionLength-TypDeckLength" />
<!--
-->
<O N="TypDeck" T="Surface" X="StartStation">

```



```

<O T="Point" C="0.75" Z="0" Y="RightEdge" />
<O T="Point" C="0.75" Z="-RightDeck_t" Y="RightEdge" AlignTB="0" />
<O T="Repeat" index="S" CTRL="index" I="1" E="numGirders-1" S="0">
  <P N="GA" V="alignT(CSAlignment, EndStation, GirderOffset[index]-0.5*HaunchWidth[index])" />
  <P N="CL" V="alignT(CSAlignment, EndStation, GirderOffset[index])" />
  <P N="GB" V="alignT(CSAlignment, EndStation, GirderOffset[index]+0.5*HaunchWidth[index])" />
  <P N="ElevCorrA" V="GA-CL" />
  <P N="ElevCorrB" V="GB-CL" />
  <O T="Point" Z="-MinDeck_t" Y="GirderOffset[index]+0.5*HaunchWidth[index]" AlignTB="0">
    <P N="Guard" V="(RightOverhangType.NE.1).OR.(index.NE.S)" />
  </O>
  <O T="Point" Z="-TopDeckToTopGirderWeb-ElevCorrB"
Y="GirderOffset[index]+0.5*HaunchWidth[index]" AlignTB="0" />
  <O T="Point" Z="-TopDeckToTopGirderWeb-ElevCorrA" Y="GirderOffset[index]-
0.5*HaunchWidth[index]" AlignTB="0" />
  <O T="Point" Z="-MinDeck_t" Y="GirderOffset[index]-0.5*HaunchWidth[index]" AlignTB="0">
    <P N="Guard" V="(LeftOverhangType.NE.1).OR.(index.NE.E)" />
  </O>
</O>
<O T="Point" C="0.75" Z="-LeftDeck_t" Y="-LeftEdge" AlignTB="0" />
<O T="Point" C="0.75" Z="0" Y="-LeftEdge" />
</O>
<O T="Surface" Extends="TypDeck" X="StartStation+TypDeckLength" />
<O N="Beam" T="Surface" X="StartStation+TypDeckLength+TransitionLength">
  <O T="Point" C="0.75" Z="0" Y="RightEdge" />
  <O T="Point" C="0.75" Z="-EndBeamDepthRight" Y="RightEdge" AlignTB="0" />
  <O T="Repeat" index="S" CTRL="index" I="1" E="numGirders-1" S="0">
    <O T="Point" Z="-EndBeamDepth" Y="GirderOffset[index]+0.5*HaunchWidth[index]" AlignTB="0">
      <P N="Guard" V="(RightOverhangType.NE.1).OR.(index.NE.S)" />
    </O>
    <O T="Point" Z="-EndBeamDepth" Y="GirderOffset[index]+0.5*HaunchWidth[index]" AlignTB="0" />
    <O T="Point" Z="-EndBeamDepth" Y="GirderOffset[index]-0.5*HaunchWidth[index]" AlignTB="0" />
    <O T="Point" Z="-EndBeamDepth" Y="GirderOffset[index]-0.5*HaunchWidth[index]" AlignTB="0">
      <P N="Guard" V="(LeftOverhangType.NE.1).OR.(index.NE.E)" />
    </O>
  </O>
  <O T="Point" C="0.75" Z="-EndBeamDepthLeft" Y="-LeftEdge" AlignTB="0" />
  <O T="Point" C="0.75" Z="0" Y="-LeftEdge" />
</O>
<O T="Surface" Extends="Beam" X="EndStation" />
</O>
</O>
<O T="Private">
  <O N="CSAlignment" T="Alignment">
    <P N="Station" V="0" />
    <P N="Azimuth" V="PI/2" />
    <O N="TangentSeg_1" T="Straight">
      <P N="Length" V="11700" />
    </O>
    <O N="Begin" T="ElevationPoint">
      <P N="Station" V="0" />
      <P N="Grade" V="0" />
      <P N="Elevation" V="0" />
    </O>
  <O N="Sta_6125" T="CrossSection">
    <P N="Station" V="0" />
  </O>
</O>

```

```

<P N="LeftEdgeToHCL" V="LeftEdge" />
<P N="ElevationAtHCL" V="0" />
<O N="LeftBarrier" T="CrossSectionSegment">
  <P N="Slope" V="-0.09876543" />
  <P N="Width" V="20.25" />
</O>
<O N="LeftShoulder" T="CrossSectionSegment">
  <P N="Slope" V="0.02" />
  <P N="Width" V="48" />
</O>
<O N="LeftShy" T="CrossSectionSegment">
  <P N="Slope" V="-0.02" />
  <P N="Width" V="24" />
</O>
<O N="Lane" T="CrossSectionSegment">
  <P N="Slope" V="-0.08" />
  <P N="Width" V="180" />
</O>
<O N="RightShoulder" T="CrossSectionSegment">
  <P N="Slope" V="-0.08" />
  <P N="Width" V="144" />
</O>
<O N="RightBarrier" T="CrossSectionSegment">
  <P N="Slope" V="0.09876543" />
  <P N="Width" V="20.25" />
</O>
</O>
</O>
</O>
<!--
Horizontal Control Line is for debugging purposes only
-->
<O T="Private">
  <O N="Horizontal Control Line" T="Line">
    <P N="Alignment" V="CSAlignment" T="Alignment" />
    <P N="Color" V="#FF0000" T="Text" />
    <O N="Simple Line" T="Section">
      <P N="w" V="1" />
      <P N="h" V="1" />
      <O T="Shape">
        <O T="Point" X="-w/2" Y="-h/2" />
        <O T="Point" X="w/2" Y="-h/2" />
        <O T="Point" X="w/2" Y="h/2" />
        <O T="Point" X="-w/2" Y="h/2" />
      </O>
    </O>
    <O T="Point" X="StartStation" Z="0" Y="0" />
    <O T="Point" X="EndStation" Z="0" Y="0" />
  </O>
</O>
<!--
CADD Drawings
-->
<O N="End Beam Section (between girders)" T="CADD">
  <O T="CADDShape" X="0" Y="0">
    <P N="Color" V="#000000" T="Text" />

```

```

<P N="Thickness" V="2" />
<P N="IsClosed" V="T" T="Text" />
<!--
-->
<O T="Point" X="StartStation" Y="0" />
<O T="Point" X="EndStation" Y="0" />
<O T="Point" X="EndStation" Y="-MinDeck_t" />
<O T="Point" X="EndStation-TypDeckLength" Y="-MinDeck_t" />
<O T="Point" X="EndStation-TypDeckLength-TransitionLength" Y="-EndBeamDepth" />
<O T="Point" X="StartStation" Y="-EndBeamDepth" C="0.75" />
</O>
<O T="CADDLine" X="0" Y="0">
  <P N="Color" V="#FF0000" T="Text" />
  <P N="Thickness" V="2" />
  <O T="Point" X="0" Y="-20" />
  <O T="Point" X="0" Y="10" />
</O>
<!--
<O T="CADDLine" X="0" Y="0">
  <P N="Color" V="#FF0000" T="Text" />
  <P N="Thickness" V="2" />
  <O T="Point" X="GirderOffset[0]" Y="-15" />
  <O T="Point" X="GirderOffset[0]" Y="-75" />
</O>
<O T="CADDLine" X="0" Y="0">
  <P N="Color" V="#FF0000" T="Text" />
  <P N="Thickness" V="2" />
  <O T="Point" X="GirderOffset[1]" Y="-5" />
  <O T="Point" X="GirderOffset[1]" Y="-65" />
</O>
<O T="CADDLine" X="0" Y="0">
  <P N="Color" V="#FF0000" T="Text" />
  <P N="Thickness" V="2" />
  <O T="Point" X="GirderOffset[2]" Y="5" />
  <O T="Point" X="GirderOffset[2]" Y="-55" />
</O>
<O T="CADDLine" X="0" Y="0">
  <P N="Color" V="#FF0000" T="Text" />
  <P N="Thickness" V="2" />
  <O T="Point" X="GirderOffset[3]" Y="10" />

  <O T="Point" X="GirderOffset[3]" Y="-50" />
</O>
<O T="CADDDimensionLine" X="0" Y="0" RZ="0">
  <P N="Label" V="LeftEdgeToHCL = %d" T="Text" />
  <O T="Point" X="-LeftEdgeToHCL" Y="10" />
  <O T="Point" X="0" Y="10" />
  <O T="Point" X="0" Y="140" />
</O>
<O T="CADDDimensionLine" X="0" Y="0" RZ="0">
  <P N="Label" V="DeckWidth = %d" T="Text" />
  <O T="Point" X="-LeftEdgeToHCL" Y="10" />
  <O T="Point" X="DeckWidth-LeftEdgeToHCL" Y="10" />
  <O T="Point" X="0" Y="160" />
</O>
<O T="CADDDimensionLine" X="0" Y="0" RZ="0">

```

```

    <P N="Label" V="w[0] = %d" T="Text" />
    <O T="Point" X="-LeftEdgeToHCL" Y="10" />
    <O T="Point" X="-LeftEdgeToHCL+w[0]" Y="10" />
    <O T="Point" X="0" Y="120" />
</O>
<O T="CADDDimensionLine" X="0" Y="0" RZ="0">
    <P N="Label" V="w[1] = %d" T="Text" />
    <O T="Point" X="-LeftEdgeToHCL+w[0]" Y="10" />
    <O T="Point" X="-LeftEdgeToHCL+w[0]+w[1]" Y="10" />
    <O T="Point" X="0" Y="110" />
</O>
<O T="CADDDimensionLine" X="0" Y="0" RZ="0">
    <P N="Label" V="w[2] = %d" T="Text" />
    <O T="Point" X="-LeftEdgeToHCL+w[0]+w[1]" Y="10" />
    <O T="Point" X="-LeftEdgeToHCL+w[0]+w[1]+w[2]" Y="10" />
    <O T="Point" X="0" Y="120" />
</O>
<O T="CADDDimensionLine" X="0" Y="0" RZ="0">
    <P N="Label" V="w[3] = %d" T="Text" />
    <O T="Point" X="-LeftEdgeToHCL+w[0]+w[1]+w[2]" Y="10" />
    <O T="Point" X="-LeftEdgeToHCL+w[0]+w[1]+w[2]+w[3]" Y="10" />
    <O T="Point" X="0" Y="110" />
</O>
<O T="CADDDimensionLine" X="0" Y="0" RZ="0">
    <P N="Label" V="w[4] = %d" T="Text" />
    <O T="Point" X="-LeftEdgeToHCL+w[0]+w[1]+w[2]+w[3]" Y="10" />
    <O T="Point" X="-LeftEdgeToHCL+w[0]+w[1]+w[2]+w[3]+w[4]" Y="10" />
    <O T="Point" X="0" Y="120" />
</O>
<O T="CADDDimensionLine" X="0" Y="0" RZ="0">
    <P N="Label" V="w[5] = %d" T="Text" />
    <O T="Point" X="-LeftEdgeToHCL+w[0]+w[1]+w[2]+w[3]+w[4]" Y="10" />
    <O T="Point" X="-LeftEdgeToHCL+w[0]+w[1]+w[2]+w[3]+w[4]+w[5]" Y="10" />
    <O T="Point" X="0" Y="110" />
</O>
-->
</O>
</O>

```

## Bent Rebar

|BentRebar| object is used as the basic template for all bent reinforcing steel bars. It is anticipated that individual bar bend types will be developed parametrically with their own library objects, and will reference this object. Any number of legs can be incorporated by the |BentRebar| object by increasing the number of array elements for the input parameters Length, AngleX, AngleY, and AngleZ.

|BentRebar| uses the Line object with the Polyline="1" parameter. The polyline is created along the centerline of the bar. Standard bar bend diagrams are detailed with to out-to-out dimensions, so individual bar bend objects will need to account for the difference in leg lengths and the bend radius.

open  
Brim BentRebar by Mike BARTHOLOMEW

Refresh Params

BarDiameter	BentRadiiFactor	Length
1	[6, 6, 0]	[100, 50, 50]
AngleX	AngleY	AngleZ
[0, 0, 0]	[0, 0, 0]	[0, 1.5708, 1.5708]

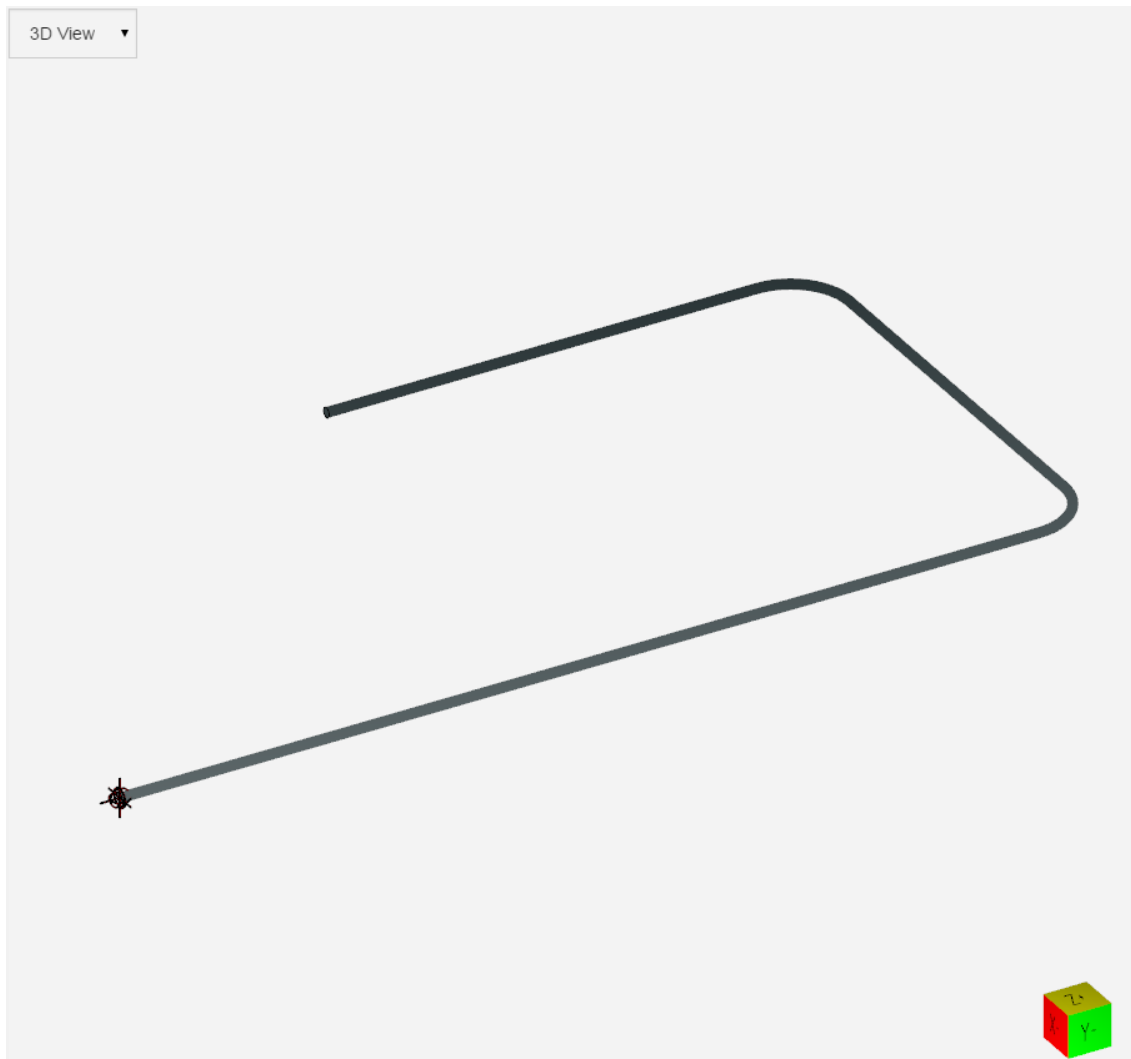

ParamML Code

```

<O N="BentRebar" T="Project">
  <P N="BarDiameter" V="1" Role="Input" />
  <P N="BentRadiiFactor" V="[6,6,0]" Role="Input" />
  <P N="Length" V="[100,50, 50]" Role="Input" />
  <P N="AngleX" V="[0,0,0]" Role="Input" />
  <P N="AngleY" V="[0,0,0]" Role="Input" />
  <P N="AngleZ" V="[0,PI/2,PI/2]" Role="Input" />
  <O N="ObjDesc" T="Group">
    <!--

```

<p> |BentRebar| object is used as the basic template for all bent reinforcing steel bars. It is anticipated that individual bar bend types will be developed parametrically with their own library objects, and will reference this object. Any number of legs can be incorporated by the |BentRebar| object by increasing the number of array elements for the input parameters Length, AngleX, AngleY, AngleZ. |BentRebar| uses the Line object with the Polyline="1" parameter. The polyline is created along the centerline of the bar. Standard bar bend diagrams are detailed with to out-to-out dimensions, so individual bar bend objects will need to account for the difference in leg lengths and the bend radius.</p>

```

-->

```

```

</O>

```

```

<O T="Line" PolyLine="1">

```

```

  <!-- first point goes in automatically at origin (0,0,0) -->

```

```

  <O T="Point" Z="0" X="0" Y="0" />

```

```

  <!--

```

the rest of the points will be repeated from the input lists.

For Each Segment:

DirAngleX, DirAngleY, DirAngleZ: the direction angle of the segment in object local axis.

L: the length of the segment.

Pt: a list representing the coordinate of end point in the local of the segment.

RotPt: it is Pt rotated with the segment direction angles (DirAngleX, DirAngleY, DirAngleZ).

PrevX, PrevY, PrevZ: the coordinates of the end point of the previous segment.

RotPtX, RotPtY, RotPtZ: the coordinates of the end point of current segment.

```

-->

```

```

<O N="Points" T="Repeat" index="0" CTRL="index" I="1" E="length(Length)-1" S="0">

```

```

  <P N="DirAngleX" V="sum(AngleX, 0, index)" />

```

```

  <P N="DirAngleY" V="sum(AngleY, 0, index)" />

```

```

  <P N="DirAngleZ" V="sum(AngleZ, 0, index)" />

```

```

  <P N="L" V="Length[index]" />

```

```

  <P N="Pt" V="[L, 0, 0]" />

```

```

  <P N="RotPt" V="rotate(Pt, DirAngleX, DirAngleY, DirAngleZ)" />

```

```

  <P N="RotPtX" V="RotPt[0]+PrevX" />

```

```

  <P N="RotPtY" V="RotPt[1]+PrevY" />

```

```

  <P N="RotPtZ" V="RotPt[2]+PrevZ" />

```

```

  <O T="Group" Guard="index.GT.0">

```

```

    <P N="PrevX" V="Points[index-1].RotPtX" />

```

```

    <P N="PrevY" V="Points[index-1].RotPtY" />

```

```

    <P N="PrevZ" V="Points[index-1].RotPtZ" />

```

```

  </O>

```

```

  <O T="Group" Guard="index.EQ.0">

```

```

    <P N="PrevX" V="0" />

```

```

    <P N="PrevY" V="0" />

```

```

    <P N="PrevZ" V="0" />

```

```

  </O>

```

```

  <O T="Point" Z="RotPtZ" X="RotPtX" Y="RotPtY" R="BentRadiiFactor[index]*BarDiameter" />

```

```

</O>

```

```

<O T="Circle" Radius="BarDiameter/2" />

```

```
</O>  
<O T="Private">  
  <O N="Reference" T="InsertionPoint" Size="2" />  
</O>  
</O>
```





# Appendix B – Example Bridge Model

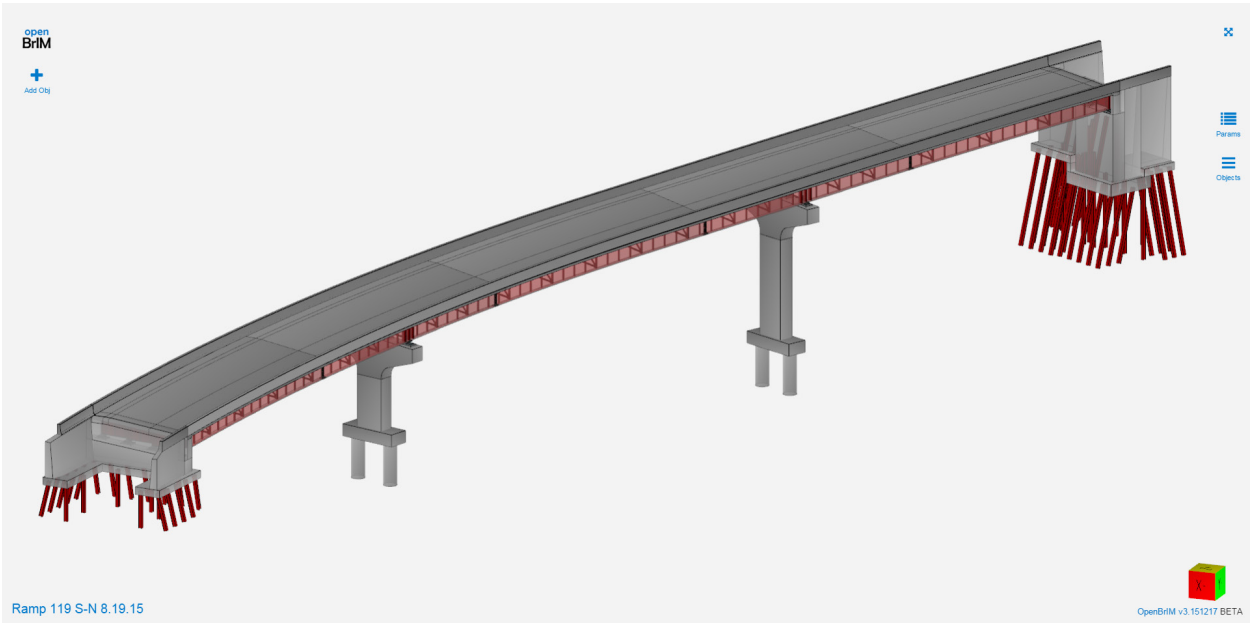



```

<O N="Ramp 119 S-N 8.19.15" T="Project">
  <P N="Alignment" V="CSAlignment" T="Alignment" />
  <O N="BridgeLayoutData" T="Group">
    <P N="EndUserInputFields" V="1" />
    <P N="CSAlignment" V="BL119S_N" T="Alignment" />
    <P N="Abut1Sta" V="6125*12" D="Station" UT="Length" UC="Layout" />
    <P N="Abut1Skew" V="0" D="Skew Angle" UT="Angle" UC="Layout" />
    <P N="Pier1Sta" V="6255*12" D="Station" UT="Length" UC="Layout" />
    <P N="Pier1 Skew" V="0" D="Skew Angle" UT="Angle" UC="Layout" />
    <P N="Pier2Sta" V="6435*12" D="Station" UT="Length" UC="Layout" />
    <P N="Pier2 Skew" V="0" D="Skew Angle" UT="Angle" UC="Layout" />
    <P N="Abut2Sta" V="6565*12" D="Station" UT="Length" UC="Layout" />
    <P N="Abut2Skew" V="0" D="Skew Angle" UT="Angle" UC="Layout" />
  </O>
  <O N="Units" T="Group">
    <O N="Internal" T="Unit">
      <P N="Length" V="INCH" T="Text" />
      <P N="Force" V="KIPS" T="Text" />
      <P N="Angle" V="RADIANS" T="Text" />
      <P N="Temperature" V="FAHRENHEIT" T="Text" />
    </O>
    <O N="Layout" T="Unit">
      <P N="Length" V="FEET" T="Text" />
      <P N="Force" V="KIPS" T="Text" />
      <P N="Angle" V="DEGREES" T="Text" />
      <P N="Temperature" V="FAHRENHEIT" T="Text" />
    </O>
    <O N="Geometry and Load" T="Unit">
      <P N="Length" V="FEET" T="Text" />
      <P N="Force" V="KIPS" T="Text" />
      <P N="Angle" V="DEGREES" T="Text" />
      <P N="Temperature" V="FAHRENHEIT" T="Text" />
    </O>
    <O N="Properties" T="Unit">
      <P N="Length" V="INCH" T="Text" />
      <P N="Force" V="KIPS" T="Text" />
      <P N="Angle" V="DEGREES" T="Text" />
      <P N="Temperature" V="FAHRENHEIT" T="Text" />
    </O>
  </O>
  <O N="Materials" T="Group">
    <O N="A709 36" T="Material">
      <P N="E" V="29000" UT="Stress" UC="Properties" />
      <P N="Nu" V="0.3" />
      <P N="d" V="0.000284" UT="Density" UC="Properties" />
      <P N="a" V="0.0000065" />
      <P N="Fy" V="36" UT="Stress" UC="Properties" />
      <P N="Fu" V="58" UT="Stress" UC="Properties" />
      <P N="Type" V="steel" T="Text" />
    </O>
    <O N="A709 50" T="Material">
      <P N="E" V="29000" UT="Stress" UC="Properties" />
      <P N="Nu" V="0.3" />
      <P N="d" V="0.000284" UT="Density" UC="Properties" />
      <P N="a" V="0.0000065" />
      <P N="Fy" V="50" UT="Stress" UC="Properties" />
      <P N="Fu" V="65" UT="Stress" UC="Properties" />
    </O>
  </O>

```

```

    <P N="Type" V="steel" T="Text" />
</O>
<O N="A709 50W" T="Material">
  <P N="E" V="29000" UT="Stress" UC="Properties" />
  <P N="Nu" V="0.3" />
  <P N="d" V="0.000284" UT="Density" UC="Properties" />
  <P N="a" V="0.0000065" />
  <P N="Fy" V="50" UT="Stress" UC="Properties" />
  <P N="Fu" V="70" UT="Stress" UC="Properties" />
  <P N="Type" V="steel" T="Text" />
</O>
<O N="A709 70W" T="Material">
  <P N="E" V="29000" UT="Stress" UC="Properties" />
  <P N="Nu" V="0.3" />
  <P N="d" V="0.000284" UT="Density" UC="Properties" />
  <P N="a" V="0.0000065" />
  <P N="Fy" V="70" UT="Stress" UC="Properties" />
  <P N="Fu" V="90" UT="Stress" UC="Properties" />
  <P N="Type" V="steel" T="Text" />
</O>
<O N="A615 60" T="Material">
  <P N="E" V="29000" UT="Stress" UC="Properties" />
  <P N="Nu" V="0.3" />
  <P N="d" V="0.000284" UT="Density" UC="Properties" />
  <P N="a" V="0.0000065" />
  <P N="Fy" V="60" UT="Stress" UC="Properties" />
  <P N="Fu" V="90" UT="Stress" UC="Properties" />
  <P N="Type" V="rebar" T="Text" />
</O>
<O N="A615 75" T="Material">
  <P N="E" V="29000" UT="Stress" UC="Properties" />
  <P N="Nu" V="0.3" />
  <P N="d" V="0.000284" UT="Density" UC="Properties" />
  <P N="a" V="0.0000065" />
  <P N="Fy" V="75" UT="Stress" UC="Properties" />
  <P N="Fu" V="100" UT="Stress" UC="Properties" />
  <P N="Type" V="rebar" T="Text" />
</O>
<O N="A706 60" T="Material">
  <P N="E" V="29000" UT="Stress" UC="Properties" />
  <P N="Nu" V="0.3" />
  <P N="d" V="0.000284" UT="Density" UC="Properties" />
  <P N="a" V="0.0000065" />
  <P N="Fy" V="60" UT="Stress" UC="Properties" />
  <P N="Fu" V="80" UT="Stress" UC="Properties" />
  <P N="Type" V="rebar" T="Text" />
</O>
<O N="Concrete f'c 3 ksi" T="Material">
  <P N="E" V="3123.84" UT="Stress" UC="Properties" />
  <P N="Nu" V="0.17" />
  <P N="d" V="0.0000868" UT="Density" UC="Properties" />
  <P N="a" V="0.000008" />
  <P N="Fc28" V="3" UT="Stress" UC="Properties" />
  <P N="Type" V="concrete" T="Text" />
</O>
<O N="Concrete f'c 4 ksi" T="Material">
  <P N="E" V="3607.1" UT="Stress" UC="Properties" />

```

```

<P N="Nu" V="0.17" />
<P N="d" V="0.0000868" UT="Density" UC="Properties" />
<P N="a" V="0.000008" />
<P N="Fc28" V="4" UT="Stress" UC="Properties" />
<P N="Type" V="concrete" T="Text" />
</O>
</O>
<O N="BL119S_N" T="Alignment">
  <P N="Station" V="72000" UT="Length" UC="Layout" />
  <P N="Azimuth" V="PI/2" UT="Angle" UC="Layout" />
  <O N="Curve_101" T="Circular">
    <P N="Length" V="4465.68" UT="Length" UC="Layout" />
    <P N="Radius" V="9168" UT="Length" UC="Layout" />
    <P N="Direction" V="Right" T="Text" />
  </O>
  <O N="TangentSeg_1" T="Straight">
    <P N="Length" V="7234.32" UT="Length" UC="Layout" />
  </O>
  <O N="Begin" T="ElevationPoint">
    <P N="Station" V="72000" UT="Length" UC="Layout" />
    <P N="Grade" V="0.0579" UT="Length" UC="Layout" />
    <P N="Elevation" V="12385.68" UT="Length" UC="Layout" />
  </O>
  <O N="VPC_1" T="ElevationPoint">
    <P N="Station" V="77100" UT="Length" UC="Layout" />
    <P N="Grade" V="0.0579" />
    <P N="Elevation" V="12680.97" UT="Length" UC="Layout" />
  </O>
  <O N="VPT_1" T="ElevationPoint">
    <P N="Station" V="83700" UT="Length" UC="Layout" />
    <P N="Grade" V="-0.005" />
    <P N="Elevation" V="12813.54" UT="Length" UC="Layout" />
  </O>
  <O N="Sta_6125" T="CrossSection">
    <P N="Station" V="73500" UT="Length" UC="Layout" />
    <P N="LeftEdgeToHCL" V="272.25" UT="Length" UC="Layout" />
    <P N="ElevationAtHCL" V="0" UT="Length" UC="Layout" />
    <O N="Left Barrier" T="CrossSectionSegment">
      <P N="Slope" V="-0.09876543" />
      <P N="Width" V="20.25" UT="Length" UC="Layout" />
    </O>
    <O N="Left Shoulder" T="CrossSectionSegment">
      <P N="Slope" V="0.02" />
      <P N="Width" V="48" UT="Length" UC="Layout" />
    </O>
    <O N="Left Shy" T="CrossSectionSegment">
      <P N="Slope" V="-0.02" />
      <P N="Width" V="24" UT="Length" UC="Layout" />
    </O>
    <O N="Lane" T="CrossSectionSegment">
      <P N="Slope" V="-0.08" />
      <P N="Width" V="180" UT="Length" UC="Layout" />
    </O>
    <O N="Right Shoulder" T="CrossSectionSegment">
      <P N="Slope" V="-0.08" />
      <P N="Width" V="144" UT="Length" UC="Layout" />
    </O>
  </O>

```

```

<O N="Right Barrier" T="CrossSectionSegment">
  <P N="Slope" V="0.09876543" />
  <P N="Width" V="20.25" UT="Length" UC="Layout" />
</O>
<O N="Sta_6372" T="CrossSection">
  <P N="Station" V="76465.68" UT="Length" UC="Layout" />
  <P N="LeftEdgeToHCL" V="272.25" UT="Length" UC="Layout" />
  <P N="ElevationAtHCL" V="0" UT="Length" UC="Layout" />
  <O N="Left Barrier" T="CrossSectionSegment">
    <P N="Slope" V="-0.09876543" />
    <P N="Width" V="20.25" UT="Length" UC="Layout" />
  </O>
  <O N="Left Shoulder" T="CrossSectionSegment">
    <P N="Slope" V="0.02" />
    <P N="Width" V="48" UT="Length" UC="Layout" />
  </O>
  <O N="Left Shy" T="CrossSectionSegment">
    <P N="Slope" V="-0.02" />
    <P N="Width" V="24" UT="Length" UC="Layout" />
  </O>
  <O N="Lane" T="CrossSectionSegment">
    <P N="Slope" V="-0.08" />
    <P N="Width" V="180" UT="Length" UC="Layout" />
  </O>
  <O N="Right Shoulder" T="CrossSectionSegment">
    <P N="Slope" V="-0.08" />
    <P N="Width" V="144" UT="Length" UC="Layout" />
  </O>
  <O N="Right Barrier" T="CrossSectionSegment">
    <P N="Slope" V="0.09876543" />
    <P N="Width" V="20.25" UT="Length" UC="Layout" />
  </O>
</O>
<O N="Sta_6444" T="CrossSection">
  <P N="Station" V="77332.08" UT="Length" UC="Layout" />
  <P N="LeftEdgeToHCL" V="272.25" UT="Length" UC="Layout" />
  <P N="ElevationAtHCL" V="0" UT="Length" UC="Layout" />
  <O N="Left Barrier" T="CrossSectionSegment">
    <P N="Slope" V="-0.09876543" />
    <P N="Width" V="20.25" UT="Length" UC="Layout" />
  </O>
  <O N="Left Shoulder" T="CrossSectionSegment">
    <P N="Slope" V="0.02" />
    <P N="Width" V="48" UT="Length" UC="Layout" />
  </O>
  <O N="Left Shy" T="CrossSectionSegment">
    <P N="Slope" V="-0.02" />
    <P N="Width" V="24" UT="Length" UC="Layout" />
  </O>
  <O N="Lane" T="CrossSectionSegment">
    <P N="Slope" V="-0.06" />
    <P N="Width" V="180" UT="Length" UC="Layout" />
  </O>
  <O N="Right Shoulder" T="CrossSectionSegment">
    <P N="Slope" V="-0.06" />
    <P N="Width" V="144" UT="Length" UC="Layout" />
  </O>

```

```

</O>
<O N="Right Barrier" T="CrossSectionSegment">
  <P N="Slope" V="0.09876543" />
  <P N="Width" V="20.25" UT="Length" UC="Layout" />
</O>
</O>
<O N="Sta_6516" T="CrossSection">
  <P N="Station" V="78198.48" UT="Length" UC="Layout" />
  <P N="LeftEdgeToHCL" V="272.25" UT="Length" UC="Layout" />
  <P N="ElevationAtHCL" V="0" UT="Length" UC="Layout" />
  <O N="Left Barrier" T="CrossSectionSegment">
    <P N="Slope" V="-0.09876543" />
    <P N="Width" V="20.25" UT="Length" UC="Layout" />
  </O>
  <O N="Left Shoulder" T="CrossSectionSegment">
    <P N="Slope" V="0.02" />
    <P N="Width" V="48" UT="Length" UC="Layout" />
  </O>
  <O N="Left Shy" T="CrossSectionSegment">
    <P N="Slope" V="0.02" />
    <P N="Width" V="24" UT="Length" UC="Layout" />
  </O>
  <O N="Lane" T="CrossSectionSegment">
    <P N="Slope" V="-0.04" />
    <P N="Width" V="180" UT="Length" UC="Layout" />
  </O>
  <O N="Right Shoulder" T="CrossSectionSegment">
    <P N="Slope" V="-0.04" />
    <P N="Width" V="144" UT="Length" UC="Layout" />
  </O>
  <O N="Right Barrier" T="CrossSectionSegment">
    <P N="Slope" V="0.09876543" />
    <P N="Width" V="20.25" UT="Length" UC="Layout" />
  </O>
</O>
</O>
<O N="Sta_6588" T="CrossSection">
  <P N="Station" V="79064.76" UT="Length" UC="Layout" />
  <P N="LeftEdgeToHCL" V="272.25" UT="Length" UC="Layout" />
  <P N="ElevationAtHCL" V="0" UT="Length" UC="Layout" />
  <O N="Left Barrier" T="CrossSectionSegment">
    <P N="Slope" V="-0.09876543" />
    <P N="Width" V="20.25" UT="Length" UC="Layout" />
  </O>
  <O N="Left Shoulder" T="CrossSectionSegment">
    <P N="Slope" V="0.04" />
    <P N="Width" V="48" UT="Length" UC="Layout" />
  </O>
  <O N="Left Shy" T="CrossSectionSegment">
    <P N="Slope" V="0.04" />
    <P N="Width" V="24" UT="Length" UC="Layout" />
  </O>
  <O N="Lane" T="CrossSectionSegment">
    <P N="Slope" V="-0.02" />
    <P N="Width" V="180" UT="Length" UC="Layout" />
  </O>
  <O N="Right Shoulder" T="CrossSectionSegment">
    <P N="Slope" V="-0.04" />

```

```

    <P N="Width" V="144" UT="Length" UC="Layout" />
  </O>
  <O N="Right Barrier" T="CrossSectionSegment">
    <P N="Slope" V="0.09876543" />
    <P N="Width" V="20.25" UT="Length" UC="Layout" />
  </O>
</O>
<O N="Straight" T="Alignment">
  <P N="Station" V="72000" UT="Length" UC="Layout" />
  <P N="Azimuth" V="PI/2" UT="Angle" UC="Layout" />
  <O N="TangentSeg_1" T="Straight">
    <P N="Length" V="11700" UT="Length" UC="Layout" />
  </O>
  <O N="Begin" T="ElevationPoint">
    <P N="Station" V="72000" UT="Length" UC="Layout" />
    <P N="Grade" V="0" />
    <P N="Elevation" V="12385.68" UT="Length" UC="Layout" />
  </O>
  <O N="VPT_1" T="ElevationPoint">
    <P N="Station" V="83700" UT="Length" UC="Layout" />
    <P N="Grade" V="0" />
    <P N="Elevation" V="12385.68" UT="Length" UC="Layout" />
  </O>
  <O N="Sta_6125" T="CrossSection">
    <P N="Station" V="73500" UT="Length" UC="Layout" />
    <P N="LeftEdgeToHCL" V="272.25" UT="Length" UC="Layout" />
    <P N="ElevationAtHCL" V="0" UT="Length" UC="Layout" />
    <O N="Left Barrier" T="CrossSectionSegment">
      <P N="Slope" V="-0.09876543" />
      <P N="Width" V="20.25" UT="Length" UC="Layout" />
    </O>
    <O N="Left Shoulder" T="CrossSectionSegment">
      <P N="Slope" V="0.02" />
      <P N="Width" V="48" UT="Length" UC="Layout" />
    </O>
    <O N="Left Shy" T="CrossSectionSegment">
      <P N="Slope" V="-0.02" />
      <P N="Width" V="24" UT="Length" UC="Layout" />
    </O>
    <O N="Lane" T="CrossSectionSegment">
      <P N="Slope" V="-0.08" />
      <P N="Width" V="180" UT="Length" UC="Layout" />
    </O>
    <O N="Right Shoulder" T="CrossSectionSegment">
      <P N="Slope" V="-0.08" />
      <P N="Width" V="144" UT="Length" UC="Layout" />
    </O>
    <O N="Right Barrier" T="CrossSectionSegment">
      <P N="Slope" V="0.09876543" />
      <P N="Width" V="20.25" UT="Length" UC="Layout" />
    </O>
  </O>
</O>
<O N="Sections" T="Group">
  <O N="L5X5X1over2" T="Section">
    <P N="Material" V="A709 50" T="Material" />

```



```

<O N="L5X5X1over2" T="Shape">
  <P N="d" V="5" D="Overall depth of member, or width of shorter leg for angles, or width of the outstanding legs of
long legs back-to-back double angles, or the width of the back-to-back legs of short legs back-to-back double angles"
UT="Length" UC="Section" />
  <P N="b" V="5" D="Width of the flat wall of square or rectangular HSS, or width of the longer leg for angles, or width of
the back-to-back legs of long legs back-to-back double angles, or width of the outstanding legs of short legs back-to-back
double angles" UT="Length" UC="Section" />
  <P N="t" V="0.5" D="Thickness of angle leg" UT="Length" UC="Section" />
  <O N="Properties" T="Group">
    <P N="Type" V="L" T="Text" />
    <P N="W" V="16.2" D="Nominal weight" UT="ForcePerLength" UC="Section" />
    <P N="A" V="4.79" D="Cross-sectional area" />
    <P N="kdes" V="1" D="Design distance from outer face of flange to web toe of fillet" UT="Length" UC="Section" />
    <P N="kdet" V="1" D="Detailing distance from outer face of flange to web toe of fillet" UT="Length" UC="Section" />
    <P N="x" V="1.42" D="Horizontal distance from designated member edge, as defined in the AISC Steel Construction
Manual, to member centroidal axis" UT="Length" UC="Section" />
    <P N="y" V="1.42" D="Vertical distance from designated member edge, as defined in the AISC Steel Construction
Manual, to member centroidal axis" UT="Length" UC="Section" />
    <P N="xp" V="0.479" D="Horizontal distance from designated member edge, as defined in the AISC Steel
Construction Manual, to member plastic neutral axis" UT="Length" UC="Section" />
    <P N="yp" V="0.479" D="Vertical distance from designated member edge, as defined in the AISC Steel Construction
Manual, to member plastic neutral axis" UT="Length" UC="Section" />
    <P N="bt" V="10" D="Slenderness ratio for single angles" />
    <P N="Ix" V="11.3" D="Moment of inertia about the x-axis" UT="Inertia" UC="Section" />
    <P N="Zx" V="5.66" D="Plastic section modulus about the x-axis" UT="Volume" UC="Section" />
    <P N="Sx" V="3.15" D="Elastic section modulus about the x-axis" UT="Volume" UC="Section" />
    <P N="rx" V="1.53" D="Radius of gyration about the x-axis" UT="Length" UC="Section" />
    <P N="Iy" V="11.3" D="Moment of inertia about the y-axis" UT="Inertia" UC="Section" />
    <P N="Zy" V="5.66" D="Plastic section modulus about the y-axis" UT="Volume" UC="Section" />
    <P N="Sy" V="3.15" D="Elastic section modulus about the y-axis" UT="Volume" UC="Section" />
    <P N="ry" V="1.53" D="Radius of gyration about the y-axis -- with no separation for double angles back-to-back"
UT="Length" UC="Section" />
    <P N="Iz" V="4.64" D="Moment of inertia about the z-axis" UT="Inertia" UC="Section" />
    <P N="rz" V="0.98" D="Radius of gyration about the z-axis" UT="Length" UC="Section" />
    <P N="Sz" V="2.29" D="Elastic section modulus about the z-axis" UT="Volume" UC="Section" />
    <P N="J" V="0.417" D="Torsional moment of inertia" UT="Inertia" UC="Section" />
    <P N="Cw" V="0.744" D="Warping constant" UT="Warp" UC="Section" />
    <P N="ro" V="2.73" D="Polar radius of gyration about the shear center" UT="Length" UC="Section" />
    <P N="H" V="0.63" D="Flexural constant" />
    <P N="tan(a)" V="1" D="Tangent of the angle between the y-y and z-z axes for single angles, where ? is shown in
Figure 3" />
    <P N="Qs" V="1" D="Reduction factor for slender unstiffened compression elements" />
    <P N="Iw" V="18" D="Moment of inertia about the w-axis" UT="Inertia" UC="Section" />
    <P N="zA" V="3.36" D="Distance from point A to center of gravity along z-axis, as shown in Figure 3" UT="Length"
UC="Section" />
    <P N="zB" V="0" D="Distance from point B to center of gravity along z-axis, as shown in Figure 3" UT="Length"
UC="Section" />
    <P N="zC" V="3.36" D="Distance from point C to center of gravity along z-axis, as shown in Figure 3" UT="Length"
UC="Section" />
    <P N="wA" V="1.7" D="Distance from point A to center of gravity along w-axis, as shown in Figure 3" UT="Length"
UC="Section" />
    <P N="wB" V="2.01" D="Distance from point B to center of gravity along w-axis, as shown in Figure 3" UT="Length"
UC="Section" />
    <P N="wC" V="1.7" D="Distance from point C to center of gravity along w-axis, as shown in Figure 3" UT="Length"
UC="Section" />
    <P N="SwA" V="5.36" D="Elastic section modulus about the w-axis at point A on cross section, as shown in Figure 3"
UT="Volume" UC="Section" />

```

```

    <P N="SwC" V="5.36" D="Elastic section modulus about the w-axis at point C on cross section, as shown in Figure 3"
UT="Volume" UC="Section" />
    <P N="SzA" V="2.72" D="Elastic section modulus about the z-axis at point A on cross section, as shown in Figure 3"
UT="Volume" UC="Section" />
    <P N="SzB" V="2.31" D="Elastic section modulus about the z-axis at point B on cross section, as shown in Figure 3"
UT="Volume" UC="Section" />
    <P N="SzC" V="2.72" D="Elastic section modulus about the z-axis at point C on cross section, as shown in Figure 3"
UT="Volume" UC="Section" />
  </O>
  <O T="Point" Y="0" X="0" />
  <O T="Point" Y="0" X="b" />
  <O T="Point" Y="t" X="b" />
  <O T="Point" Y="t" X="t" />
  <O T="Point" Y="d" X="t" />
  <O T="Point" Y="d" X="0" />
</O>
</O>
</O>
<O N="Substructure" T="Group">
  <O N="Abutments" T="Group">
    <O N="Abument Data" T="Group">
      <P N="EndUserInputFields" V="1" />
      <P N="Abut1H" V="84" D="" />
      <P N="Abut2H" V="130" D="" />
      <P N="AbutOffset" V="-54" D="" />
      <P N="AbutColor" V="#D3D3D3" T="Text" />
      <P N="AbutOpacity" V="0.2" />
      <P N="FootT" V="30" D="" />
      <P N="FootL" V="108" D="" />
      <P N="Abut1WorkPointOffset" V="alignT(CSAlignment,Abut1Sta,AbutOffset)-80.375-10.625" />
      <P N="Abut2WorkPointOffset" V="alignT(CSAlignment,Abut2Sta,AbutOffset)-80.375-10.625-8.04" />
      <P N="PileBatter" V="3/12" D="" />
      <P N="A2aBotFooting" V="1036*12" D="" />
      <P N="A2bBotFooting" V="1029*12" D="" />
      <P N="A1PileTip" V="1008*12" D="" />
      <P N="A2PileTip" V="1005*12" D="" />
    <O N="Pile Data" T="Group">
      <O N="pile" T="Section" D="HP 12x74">
        <P N="EndUserInputFields" V="1" />
        <P N="bf" V="12.295" D="" />
        <P N="tf" V="0.685" D="" />
        <P N="tw" V="0.685" D="" />
        <P N="d" V="12.28" D="" />
      <O T="Shape">
        <O T="Point" X="-bf/2" Y="d/2" />
        <O T="Point" X="bf/2" Y="d/2" />
        <O T="Point" X="bf/2" Y="d/2-tf" />
        <O T="Point" X="tw/2" Y="d/2-tf" />
        <O T="Point" X="tw/2" Y="-d/2+tf" />
        <O T="Point" X="bf/2" Y="-d/2+tf" />
        <O T="Point" X="bf/2" Y="-d/2" />
        <O T="Point" X="-bf/2" Y="-d/2" />
        <O T="Point" X="-bf/2" Y="-d/2+tf" />
        <O T="Point" X="-tw/2" Y="-d/2+tf" />
        <O T="Point" X="-tw/2" Y="d/2-tf" />
        <O T="Point" X="-bf/2" Y="d/2-tf" />
      </O>
    </O>
  </O>
</O>

```

```

</O>
</O>
</O>
<O N="Abut1" T="Group" X="Abut1Sta-12" Y="AbutOffset" Z="Abut1WorkPointOffset" RZ="Abut1Skew" AlignH="Orient"
AlignV="None" AlignT="None">
  <O T="Stem Abutment (BB)">
    <P N="Color" V="#D3D3D3" T="Text" />
    <P N="Opacity" V="0.9" />
    <P N="FootingLength" V="108" D="Footing Length (Along Bridge Alignment)" />
    <P N="FootingWidth" V="484.5" D="Footing Width (Transverse to Bridge Alignment)" />
    <P N="FootingDepth" V="30" D="Footing Depth" />
    <P N="FootingCL_HZoffset" V="FootingWidth/2" D="Distance from CL footing to CL Abutment" />
    <P N="FootingCL_Latoffset" V="54" D="" />
    <P N="AbutLength" V="436" D="Total Abut Length" />
    <P N="StemWidth" V="60" D="Abut Width" />
    <P N="PedSlope" V="0.069" D="Slope of surface for pedestal mounts" />
    <P N="BackWallHeight" V="83.3" D="" />
    <P N="BackWallThick" V="24" D="" />
    <P N="BackWallNotchH" V="9" D="" />
    <P N="BackWallNotchV" V="20" D="" />
    <P N="StemH" V="69.64" D="Stem Height at Center" />
    <P N="PedestalTopWidth" V="46" D="Top Width of the Girder Supports" />
    <P N="PedestalBotWidth" V="46" D="Bottom Width of the Girder Supports" />
    <P N="PedestalL1" V="36" D="Length of Girder Support 1" />
    <P N="PedestalDepth" V="[3.14,5.73,4.47,3.22]" D="Depth of Girder Supports" />
    <P N="PedestalLocations1" V="[171, 57, -57, -171]" D="Location of Pedestal set 1 from CL Abut" />
    <P N="PedestalOffset1" V="12" D="Location of edge of girder support from edge of pedestal" />
  </O>
  <O T="Abutment Backwall 2" RZ="0.0085">
    <P N="Color" V="#D3D3D3" T="Text" />
    <P N="Opacity" V="0.9" />
    <P N="AbutLength" V="436" />
    <P N="StemWidth" V="60" />
    <P N="BackWallHeight" V="86.32" />
    <P N="BackWallThick" V="24" />
    <P N="BackWallNotchH" V="9" />
    <P N="BackWallNotchV" V="20" />
    <P N="stubR" V="20.25" />
    <P N="stubL" V="20.25" />
    <P N="PedSlope" V="0.069" />
    <P N="ADJLF" V="8-alignT(Alignment, Abut1Sta, AbutLength/2+AbutOffset)" />
    <P N="ADJRF" V="8-alignT(Alignment, Abut1Sta, -AbutLength/2+AbutOffset)" />
    <P N="ADJLM" V="ADJLF" />
    <P N="ADJRM" V="ADJRF" />
    <P N="ADJLB" V="ADJLF" />
    <P N="ADJRB" V="ADJRF" />
  </O>
  <O N="Cheek Walls" T="Group">
    <O T="Cheekwall" Y="AbutLength/2-Width/2" Z="AbutLength/2*PedSlope" X="-StemWidth/2+BackWallThick">
      <P N="Color" V="#D3D3D3" T="Text" />
      <P N="Opacity" V="0.9" />
      <P N="Height" V="79.68" />
      <P N="Width" V="10" />
      <P N="Length" V="36" />
      <P N="PedSlope" V="0.069" />
      <P N="TopSlope" V="-0.0567" />
    </O>
  </O>

```

```

<O T="Cheekwall" Y="-AbutLength/2+Width/2" Z="-AbutLength/2*PedSlope" X="-StemWidth/2+BackWallThick">
  <P N="Color" V="#D3D3D3" T="Text" />
  <P N="Opacity" V="0.9" />
  <P N="Height" V="84.32" />
  <P N="Width" V="10" />
  <P N="Length" V="36" />
  <P N="PedSlope" V="0.069" />
  <P N="TopSlope" V="-0.0567" />
</O>
</O>
<O T="Abutment U-Shaped Footing" RZ="-PI/2">
  <P N="Color" V="#D3D3D3" T="Text" />
  <P N="Opacity" V="0.9" />
  <P N="Length" V="484.5" D="Footing Length (Transverse to Bridge Alignment)" />
  <P N="Width" V="108" D="Footing Width (Along Bridge Alignment)" />
  <P N="WWA_Length" V="384" D="Footing Length (Transverse to Bridge Alignment)" />
  <P N="WWA_Width" V="108" D="Footing Width (Along Bridge Alignment)" />
  <P N="WWB_Length" V="324" D="Footing Length (Transverse to Bridge Alignment)" />
  <P N="WWB_Width" V="108" D="Footing Width (Along Bridge Alignment)" />
  <P N="Depth" V="30" D="Footing Depth" />
  <P N="BotElev" V="-StemH-Depth" D="Footing Bottom Elevation" />
  <P N="CL_Bearing" V="54" D="CL Bearing to Front Edge of Footing" />
  <P N="HCL_Offset" V="484.5/2" D="HCL to Left Edge of Footing" />
</O>
<O N="Pot Bearings" T="Group" Z="-1.25">
  <P N="potlocs" V="[-171, -57, 57, 171]" />
  <P N="PedSlope" V="-0.069" />
  <O T="Pot Bearing" X="12" Y="potlocs[0]" Z="-potlocs[0]*PedSlope+PedestalDepth[3]">
    <P N="w" V="16.75" D="Width of the masonry plate (B), in." Role="Input" />
    <P N="h" V="34.5" D="Length of the masonry plate (C), in." Role="Input" />
    <P N="t" V="2.625" D="Thickness of the masonry plate (A), in." Role="Input" />
    <P N="D" V="14.625" D="Distance of bolt holes from CL (D), in." Role="Input" />
    <P N="r" V="1" D="Radius of bolt holes, in." Role="Input" />
    <P N="c" V="0" D="Depth of piston compression (to match girder elevation), in." Role="Input" />
    <P N="Sta" V="Abut1Sta" />
  </O>
  <O T="Pot Bearing" X="12" Y="potlocs[1]" Z="-potlocs[1]*PedSlope+PedestalDepth[2]">
    <P N="w" V="16.75" D="Width of the masonry plate (B), in." Role="Input" />
    <P N="h" V="34.5" D="Length of the masonry plate (C), in." Role="Input" />
    <P N="t" V="2.625" D="Thickness of the masonry plate (A), in." Role="Input" />
    <P N="D" V="14.625" D="Distance of bolt holes from CL (D), in." Role="Input" />
    <P N="r" V="1" D="Radius of bolt holes, in." Role="Input" />
    <P N="c" V="0" D="Depth of piston compression (to match girder elevation), in." Role="Input" />
    <P N="Sta" V="Abut1Sta" />
  </O>
  <O T="Pot Bearing" X="12" Y="potlocs[2]" Z="-potlocs[2]*PedSlope+PedestalDepth[1]">
    <P N="w" V="16.75" D="Width of the masonry plate (B), in." Role="Input" />
    <P N="h" V="34.5" D="Length of the masonry plate (C), in." Role="Input" />
    <P N="t" V="2.625" D="Thickness of the masonry plate (A), in." Role="Input" />
    <P N="D" V="14.625" D="Distance of bolt holes from CL (D), in." Role="Input" />
    <P N="r" V="1" D="Radius of bolt holes, in." Role="Input" />
    <P N="c" V="0" D="Depth of piston compression (to match girder elevation), in." Role="Input" />
    <P N="Sta" V="Abut1Sta" />
  </O>
  <O T="Pot Bearing" X="12" Y="potlocs[3]" Z="-potlocs[3]*PedSlope+PedestalDepth[0]">
    <P N="w" V="16.75" D="Width of the masonry plate (B), in." Role="Input" />
    <P N="h" V="34.5" D="Length of the masonry plate (C), in." Role="Input" />
  </O>

```

```

    <P N="t" V="2.625" D="Thickness of the masonry plate (A), in." Role="Input" />
    <P N="D" V="14.625" D="Distance of bolt holes from CL (D), in." Role="Input" />
    <P N="r" V="1" D="Radius of bolt holes, in." Role="Input" />
    <P N="c" V="0" D="Depth of piston compression (to match girder elevation), in." Role="Input" />
    <P N="Sta" V="Abut1Sta" />
  </O>
</O>
<O N="Abut 1 Piles" T="Group" Z="-69.64-30+12">
  <O T="Pile (BB)" X="36" Y="-3*74.75">
    <P N="Batter" V="PileBatter" D="Batter Slope H:V" />
    <P N="Phi" V="0" D="Batter Orientation" />
    <P N="Beta" V="0" D="Web Orientation" />
    <P N="L" V="150" D="Length" />
    <P N="PileSection" V="pile" T="Section" />
  </O>
  <O T="Pile (BB)" X="36" Y="-2*74.75">
    <P N="Batter" V="PileBatter" D="Batter Slope H:V" />
    <P N="Phi" V="0" D="Batter Orientation" />
    <P N="Beta" V="0" D="Web Orientation" />
    <P N="L" V="150" D="Length" />
    <P N="PileSection" V="pile" T="Section" D="Length" />
  </O>
  <O T="Pile (BB)" X="36" Y="-74.75">
    <P N="Batter" V="PileBatter" D="Batter Slope H:V" />
    <P N="Phi" V="0" D="Batter Orientation" />
    <P N="Beta" V="0" D="Web Orientation" />
    <P N="L" V="150" D="Length" />
    <P N="PileSection" V="pile" T="Section" D="Length" />
  </O>
  <O T="Pile (BB)" X="36" Y="0">
    <P N="Batter" V="PileBatter" D="Batter Slope H:V" />
    <P N="Phi" V="0" D="Batter Orientation" />
    <P N="Beta" V="0" D="Web Orientation" />
    <P N="L" V="150" D="Length" />
    <P N="PileSection" V="pile" T="Section" D="Length" />
  </O>
  <O T="Pile (BB)" X="36" Y="74.75">
    <P N="Batter" V="PileBatter" D="Batter Slope H:V" />
    <P N="Phi" V="0" D="Batter Orientation" />
    <P N="Beta" V="0" D="Web Orientation" />
    <P N="L" V="150" D="Length" />
    <P N="PileSection" V="pile" T="Section" D="Length" />
  </O>
  <O T="Pile (BB)" X="36" Y="2*74.75">
    <P N="Batter" V="PileBatter" D="Batter Slope H:V" />
    <P N="Phi" V="0" D="Batter Orientation" />
    <P N="Beta" V="0" D="Web Orientation" />
    <P N="L" V="150" D="Length" />
    <P N="PileSection" V="pile" T="Section" D="Length" />
  </O>
  <O T="Pile (BB)" X="36" Y="3*74.75">
    <P N="Batter" V="PileBatter" D="Batter Slope H:V" />
    <P N="Phi" V="0" D="Batter Orientation" />
    <P N="Beta" V="0" D="Web Orientation" />
    <P N="L" V="150" D="Length" />
    <P N="PileSection" V="pile" T="Section" D="Length" />
  </O>
</O>

```

```

<O T="Pile (BB)" X="-36" Y="3*74.75">
  <P N="Batter" V="PileBatter" D="Batter Slope H:V" />
  <P N="Phi" V="PI/2" D="Batter Orientation" />
  <P N="Beta" V="0" D="Web Orientation" />
  <P N="L" V="150" D="Length" />
  <P N="PileSection" V="pile" T="Section" D="Length" />
</O>
<O T="Pile (BB)" X="-36" Y="1*74.75">
  <P N="Batter" V="0" D="Batter Slope H:V" />
  <P N="Phi" V="0" D="Batter Orientation" />
  <P N="Beta" V="0" D="Web Orientation" />
  <P N="L" V="150" D="Length" />
  <P N="PileSection" V="pile" T="Section" D="Length" />
</O>
<O T="Pile (BB)" X="-36" Y="-1*74.75">
  <P N="Batter" V="0" D="Batter Slope H:V" />
  <P N="Phi" V="0" D="Batter Orientation" />
  <P N="Beta" V="0" D="Web Orientation" />
  <P N="L" V="150" D="Length" />
  <P N="PileSection" V="pile" T="Section" D="Length" />
</O>
<O T="Pile (BB)" X="-36" Y="-3*74.75">
  <P N="Batter" V="PileBatter" D="Batter Slope H:V" />
  <P N="Phi" V="-PI/2" D="Batter Orientation" />
  <P N="Beta" V="0" D="Web Orientation" />
  <P N="L" V="150" D="Length" />
  <P N="PileSection" V="pile" T="Section" D="Length" />
</O>
<O T="Pile (BB)" X="-36-1*69" Y="3*74.75">
  <P N="Batter" V="PileBatter" D="Batter Slope H:V" />
  <P N="Phi" V="PI/2" D="Batter Orientation" />
  <P N="Beta" V="0" D="Web Orientation" />
  <P N="L" V="150" D="Length" />
  <P N="PileSection" V="pile" T="Section" />
</O>
<O T="Pile (BB)" X="-108" Y="-3*74.75">
  <P N="Batter" V="PileBatter" D="Batter Slope H:V" />
  <P N="Phi" V="-PI/2" D="Batter Orientation" />
  <P N="Beta" V="0" D="Web Orientation" />
  <P N="L" V="150" D="Length" />
  <P N="PileSection" V="pile" T="Section" />
</O>
<O T="Pile (BB)" X="-108" Y="-2*74.75">
  <P N="Batter" V="0" D="Batter Slope H:V" />
  <P N="Phi" V="0" D="Batter Orientation" />
  <P N="Beta" V="PI/2" D="Web Orientation" />
  <P N="L" V="150" D="Length" />
  <P N="PileSection" V="pile" T="Section" D="Length" />
</O>
<O T="Pile (BB)" X="-180" Y="-3*74.75">
  <P N="Batter" V="PileBatter" D="Batter Slope H:V" />
  <P N="Phi" V="-PI/2" D="Batter Orientation" />
  <P N="Beta" V="0" D="Web Orientation" />
  <P N="L" V="150" D="Length" />
  <P N="PileSection" V="pile" T="Section" />
</O>
<O T="Pile (BB)" X="-36-2*69" Y="3*74.75">

```

```

<P N="Batter" V="PileBatter" D="Batter Slope H:V" />
<P N="Phi" V="PI/2" D="Batter Orientation" />
<P N="Beta" V="0" D="Web Orientation" />
<P N="L" V="150" D="Length" />
<P N="PileSection" V="pile" T="Section" />
</O>
<O T="Pile (BB)" X="-36-2*69" Y="2*74.75">
  <P N="Batter" V="0" D="Batter Slope H:V" />
  <P N="Phi" V="0" D="Batter Orientation" />
  <P N="Beta" V="PI/2" D="Web Orientation" />
  <P N="L" V="150" D="Length" />
  <P N="PileSection" V="pile" T="Section" D="Length" />
</O>
<O T="Pile (BB)" X="-36-3*69" Y="3*74.75">
  <P N="Batter" V="PileBatter" D="Batter Slope H:V" />
  <P N="Phi" V="PI/2" D="Batter Orientation" />
  <P N="Beta" V="0" D="Web Orientation" />
  <P N="L" V="150" D="Length" />
  <P N="PileSection" V="pile" T="Section" />
</O>
<O T="Pile (BB)" X="-252" Y="-3*74.75">
  <P N="Batter" V="PileBatter" D="Batter Slope H:V" />
  <P N="Phi" V="-PI/2" D="Batter Orientation" />
  <P N="Beta" V="0" D="Web Orientation" />
  <P N="L" V="150" D="Length" />
  <P N="PileSection" V="pile" T="Section" />
</O>
<O T="Pile (BB)" X="-252" Y="-2*74.75">
  <P N="Batter" V="0" D="Batter Slope H:V" />
  <P N="Phi" V="0" D="Batter Orientation" />
  <P N="Beta" V="PI/2" D="Web Orientation" />
  <P N="L" V="150" D="Length" />
  <P N="PileSection" V="pile" T="Section" D="Length" />
</O>
<O T="Pile (BB)" X="-36-4*69" Y="3*74.75">
  <P N="Batter" V="PileBatter" D="Batter Slope H:V" />
  <P N="Phi" V="PI/2" D="Batter Orientation" />
  <P N="Beta" V="0" D="Web Orientation" />
  <P N="L" V="150" D="Length" />
  <P N="PileSection" V="pile" T="Section" />
</O>
<O T="Pile (BB)" X="-36-4*69" Y="2*74.75">
  <P N="Batter" V="0" D="Batter Slope H:V" />
  <P N="Phi" V="0" D="Batter Orientation" />
  <P N="Beta" V="PI/2" D="Web Orientation" />
  <P N="L" V="150" D="Length" />
  <P N="PileSection" V="pile" T="Section" D="Length" />
</O>
</O>
<O N="Wing Walls" T="Group">
  <O T="Wing Wall (BB)" X="-StemWidth/2" Y="-AbutLength/2+16" Z="-StemH" RZ="PI">
    <P N="Color" V="#D3D3D3" T="Text" />
    <P N="Opacity" V="0.9" />
    <P N="Length" V="239.5" D="Total Wall Longitudinal Length" />
    <P N="DistanceToCrown" V="174" D="Distance from left side to Crown" />
    <P N="Base_Width" V="32" D="Wall Width at Base" />
    <P N="Top_Width" V="1/12" D="Ratio of Wall Width at Top to Height" />
  </O>

```

```

    <P N="Top_Wall_Height" V="143.42+3" D="Height of wall at higher end" />
    <P N="Crown_Height" V="133.26+3" D="Height of wall at crown" />
    <P N="Lower_Wall_Height" V="119.1+3" D="Height of wall at lower end" />
    <P N="Skew" V="0.2" D="Skew angle of end of wall" />
    <P N="Slope" V="1" D="Wall sloped to the '1' for Right or '2' for Left" />
    <P N="rSlope" V="0.0988" D="Slope of rail on top of wall." Role="Input" />
</O>
<O T="Wing Wall (BB)" X="-StemWidth/2" Y="AbutLength/2-16" Z="-StemH" RZ="PI">
    <P N="Color" V="#D3D3D3" T="Text" />
    <P N="Opacity" V="0.9" />
    <P N="Length" V="299.5" D="Total Wall Longitudinal Length" />
    <P N="DistanceToCrown" V="234" D="Distance from left side to Crown" />
    <P N="Base_Width" V="32+2.404" D="Wall Width at Base" />
    <P N="Top_Width" V="1/12" D="Ratio of Wall Width at Top to Height" />
    <P N="Top_Wall_Height" V="167.86+2" D="Height of wall at higher end" />
    <P N="Crown_Height" V="155.22+2" D="Height of wall at crown" />
    <P N="Lower_Wall_Height" V="141.06+2" D="Height of wall at lower end" />
    <P N="Skew" V="0.2" D="Skew angle of end of wall" />
    <P N="Slope" V="2" D="Wall sloped to the '1' for Right or '2' for Left" />
    <P N="rSlope" V="0.0988" D="Slope of rail on top of wall." Role="Input" />
</O>
</O>
<O N="Bridge Rail" T="Group" AlignH="Warp" AlignV="Warp" Y="-AbutOffset" Z="-Abut1WorkPointOffset-0.75">
    <O T="PA Turnpike Barrier New" X="-6">
        <P N="Station" V="-176-24" />
        <P N="Length" V="177+24" />
        <P N="Offset" V="144" />
        <P N="type" V="RIGHT" />
    </O>
    <O T="PA Turnpike Barrier New" X="-6">
        <P N="Station" V="-227-24" />
        <P N="Length" V="225+24" />
        <P N="Offset" V="-252" />
        <P N="type" V="LEFT" />
    </O>
</O>
</O>
<O N="Abut2" T="Group">
    <O N="Abut2 Walls" T="Group" RZ="Abut2Skew" AlignH="Orient" AlignV="None" AlignT="None" X="Abut2Sta+12"
Y="AbutOffset" Z="Abut2WorkPointOffset">
        <O T="Abutment Backwall 2" RZ="PI" Y="-109.125">
            <P N="Color" V="#D3D3D3" T="Text" />
            <P N="Opacity" V="0.9" />
            <P N="S1" V="Abut2Sta+12" />
            <P N="AbutLength" V="218.25" />
            <P N="StemWidth" V="60" />
            <P N="BackWallHeight" V="97.5" />
            <P N="BackWallThick" V="24" />
            <P N="BackWallNotchH" V="9" />
            <P N="BackWallNotchV" V="20" />
            <P N="stubR" V="20.25" />
            <P N="stubL" V="0" />
            <P N="PedSlope" V="0" />
            <P N="ADJLF" V="alignT(Alignment, S1, 13)" />
            <P N="ADJRF" V="-2+alignT(Alignment, S1, -AbutLength+AbutOffset)" />
            <P N="ADJLM" V="ADJLF" />
            <P N="ADJRM" V="ADJRF" />
        </O>
    </O>
</O>

```



```

    <P N="ADJLB" V="ADJLF" />
    <P N="ADJRB" V="ADJRF" />
</O>
<O T="Abutment Backwall 2" RZ="PI" Y="109.125">
    <P N="Color" V="#D3D3D3" T="Text" />
    <P N="Opacity" V="0.9" />
    <P N="S1" V="Abut2Sta+12" />
    <P N="AbutLength" V="218.25" />
    <P N="StemWidth" V="60" />
    <P N="BackWallHeight" V="97.8" />
    <P N="BackWallThick" V="24" />
    <P N="BackWallNotchH" V="9" />
    <P N="BackWallNotchV" V="20" />
    <P N="stubR" V="0" />
    <P N="stubL" V="20.25" />
    <P N="PedSlope" V="0" />
    <P N="ADJLF" V="-10+alignT(Alignment, S1, -AbutLength-AbutOffset)" />
    <P N="ADJRF" V="alignT(Alignment, S1, 13)" />
    <P N="ADJLM" V="ADJLF" />
    <P N="ADJRM" V="ADJRF" />
    <P N="ADJLB" V="ADJLF" />
    <P N="ADJRB" V="ADJRF" />
</O>
<O T="Stem Abutment (BB)" RZ="PI" Y="-6">
    <P N="Color" V="#D3D3D3" T="Text" />
    <P N="Opacity" V="0.9" />
    <P N="AbutLength" V="218.25" D="Total Abut Length" />
    <P N="StemWidth" V="60" D="Abut Width" />
    <P N="PedSlope" V="0" D="Slope of surface for pedestal mounts" />
    <P N="StemH" V="206.04" D="Left Min Depth" />
    <P N="PedestalTopWidth" V="46" D="Top Width of the Girder Supports" />
    <P N="PedestalBotWidth" V="46" D="Bottom Width of the Girder Supports" />
    <P N="PedestalL1" V="36" D="Length of Girder Support 1" />
    <P N="PedestalDepth" V="[9.6,9.84]" D="Depth of Girder Supports" />
    <P N="PedestalLocations1" V="[57-6, -57-6]" D="Location of Pedestal set 1 from CL Abut" />
    <P N="PedestalOffset1" V="12" D="Location of edge of girder support from edge of pedestal" />
    <P N="BackWallHeight" V="85" />
    <P N="BackWallThick" V="24" />
    <P N="BackWallNotchH" V="9" />
    <P N="BackWallNotchV" V="20" />
</O>
<O T="Stem Abutment (BB)" RZ="PI" Y="-109.125*2-6">
    <P N="Color" V="#D3D3D3" T="Text" />
    <P N="Opacity" V="0.9" />
    <P N="AbutLength" V="218.25" D="Total Abut Length" />
    <P N="StemWidth" V="60" D="Abut Width" />
    <P N="PedSlope" V="0" D="Slope of surface for pedestal mounts" />
    <P N="StemH" V="272.04" D="Left Min Depth" />
    <P N="PedestalTopWidth" V="46" D="Top Width of the Girder Supports" />
    <P N="PedestalBotWidth" V="46" D="Bottom Width of the Girder Supports" />
    <P N="PedestalL1" V="36" D="Length of Girder Support 1" />
    <P N="PedestalDepth" V="[1.56,6.48]" D="Depth of Girder Supports" />
    <P N="PedestalLocations1" V="[57+6,-57+6]" D="Location of Pedestal set 1 from CL Abut" />
    <P N="PedestalOffset1" V="12" D="Location of edge of girder support from edge of pedestal" />
    <P N="BackWallHeight" V="85" />
    <P N="BackWallThick" V="24" />
    <P N="BackWallNotchH" V="9" />

```

```

    <P N="BackWallNotchV" V="20" />
</O>
<O N="Pot Bearings" T="Group" Y="-3">
    <P N="potlocs2" V="[57, -57, -171, -285]" />
    <P N="PedSlope" V="0" />
    <P N="grade" V="BL119S_N.VPC_1.Grade" />
    <O T="Pot Bearing" X="-12" Y="potlocs2[0]" Z="9.6">
        <P N="w" V="16.75" D="Width of the masonry plate (B), in." Role="Input" />
        <P N="h" V="34.5" D="Length of the masonry plate (C), in." Role="Input" />
        <P N="t" V="2.625" D="Thickness of the masonry plate (A), in." Role="Input" />
        <P N="D" V="14.625" D="Distance of bolt holes from CL (D), in." Role="Input" />
        <P N="r" V="1" D="Radius of bolt holes, in." Role="Input" />
        <P N="c" V="0" D="Depth of piston compression (to match girder elevation), in." Role="Input" />
        <P N="Sta" V="Abut2Sta" />
    </O>
    <O T="Pot Bearing" X="-12" Y="potlocs2[1]" Z="9.84">
        <P N="w" V="16.75" D="Width of the masonry plate (B), in." Role="Input" />
        <P N="h" V="34.5" D="Length of the masonry plate (C), in." Role="Input" />
        <P N="t" V="2.625" D="Thickness of the masonry plate (A), in." Role="Input" />
        <P N="D" V="14.625" D="Distance of bolt holes from CL (D), in." Role="Input" />
        <P N="r" V="1" D="Radius of bolt holes, in." Role="Input" />
        <P N="c" V="0" D="Depth of piston compression (to match girder elevation), in." Role="Input" />
        <P N="Sta" V="Abut2Sta" />
    </O>
    <O T="Pot Bearing" X="-12" Y="potlocs2[2]" Z="6.48">
        <P N="w" V="16.75" D="Width of the masonry plate (B), in." Role="Input" />
        <P N="h" V="34.5" D="Length of the masonry plate (C), in." Role="Input" />
        <P N="t" V="2.625" D="Thickness of the masonry plate (A), in." Role="Input" />
        <P N="D" V="14.625" D="Distance of bolt holes from CL (D), in." Role="Input" />
        <P N="r" V="1" D="Radius of bolt holes, in." Role="Input" />
        <P N="c" V="0" D="Depth of piston compression (to match girder elevation), in." Role="Input" />
        <P N="Sta" V="Abut2Sta" />
    </O>
    <O T="Pot Bearing" X="-12" Y="potlocs2[3]" Z="1.56">
        <P N="w" V="16.75" D="Width of the masonry plate (B), in." Role="Input" />
        <P N="h" V="34.5" D="Length of the masonry plate (C), in." Role="Input" />
        <P N="t" V="2.625" D="Thickness of the masonry plate (A), in." Role="Input" />
        <P N="D" V="14.625" D="Distance of bolt holes from CL (D), in." Role="Input" />
        <P N="r" V="1" D="Radius of bolt holes, in." Role="Input" />
        <P N="c" V="0" D="Depth of piston compression (to match girder elevation), in." Role="Input" />
        <P N="Sta" V="Abut2Sta" />
    </O>
</O>
</O>
<O N="Cheek Walls" T="Group" RZ="Abut2Skew" AlignH="Orient" AlignV="None" AlignT="None" X="Abut2Sta+12"
Y="AbutOffset" Z="Abut2WorkPointOffset">
    <O T="Cheekwall" Y="AbutLength-Width/2" Z="2" X="-StemWidth/2">
        <P N="Color" V="#D3D3D3" T="Text" />
        <P N="Opacity" V="0.9" />
        <P N="Height" V="87.96+7.5" />
        <P N="Width" V="10" />
        <P N="Length" V="36" />
        <P N="PedSlope" V="0" />
        <P N="TopSlope" V="-0.0433" />
    </O>
    <O T="Cheekwall" Y="-AbutLength+Width/2" Z="2" X="-StemWidth/2">
        <P N="Color" V="#D3D3D3" T="Text" />

```

```

    <P N="Opacity" V="0.9" />
    <P N="Height" V="80.2+7.5" />
    <P N="Width" V="10" />
    <P N="Length" V="36" />
    <P N="PedSlope" V="0" />
    <P N="TopSlope" V="-0.0433" />
  </O>
</O>
<O N="Abut2a Footings" T="Group" RZ="Abut2Skew" AlignH="Orient" AlignV="None" AlignT="None" X="Abut2Sta+12"
Y="-AbutOffset-6-109.125*2" Z="Abut2WorkPointOffset-5.5">
  <O T="Rectangular Footing" X="24+142+14" Y="115.125-147/2">
    <P N="Color" V="#D3D3D3" T="Text" />
    <P N="Opacity" V="0.9" />
    <P N="Length" V="198" D="Footing Length (Along Bridge Alignment)" />
    <P N="Width" V="147" D="Footing Width (Transverse to Bridge Alignment)" />
    <P N="Depth" V="30" D="Footing Depth" />
    <P N="BotElev" V="-206.04+54" D="Footing Bottom Elevation" />
  </O>
  <O T="Rectangular Footing" X="24">
    <P N="Color" V="#D3D3D3" T="Text" />
    <P N="Opacity" V="0.9" />
    <P N="Length" V="162" D="Footing Length (Along Bridge Alignment)" />
    <P N="Width" V="230.25" D="Footing Width (Transverse to Bridge Alignment)" />
    <P N="Depth" V="30" D="Footing Depth" />
    <P N="BotElev" V="-206.04-30" D="Footing Bottom Elevation" />
  </O>
</O>
<O N="Abut 2a Piles" T="Group" RZ="Abut2Skew" AlignH="Orient" AlignV="None" AlignT="None" X="Abut2Sta+12"
Y="AbutOffset-109.125*2-18" Z="Abut2WorkPointOffset-206.04-30+12-5.5">
  <O T="Pile (BB)" X="12-48" Y="-0.5*58.75">
    <P N="Batter" V="PileBatter" D="Batter Slope H:V" />
    <P N="Phi" V="PI" D="Batter Orientation" />
    <P N="Beta" V="0" D="Web Orientation" />
    <P N="L" V="384" D="Length" />
    <P N="PileSection" V="pile" T="Section" D="Length" />
  </O>
  <O T="Pile (BB)" X="12-48" Y="-1.5*58.75">
    <P N="Batter" V="PileBatter" D="Batter Slope H:V" />
    <P N="Phi" V="PI" D="Batter Orientation" />
    <P N="Beta" V="0" D="Web Orientation" />
    <P N="L" V="384" D="Length" />
    <P N="PileSection" V="pile" T="Section" D="Length" />
  </O>
  <O T="Pile (BB)" X="12-48" Y="0.5*58.75">
    <P N="Batter" V="PileBatter" D="Batter Slope H:V" />
    <P N="Phi" V="PI" D="Batter Orientation" />
    <P N="Beta" V="0" D="Web Orientation" />
    <P N="L" V="384" D="Length" />
    <P N="PileSection" V="pile" T="Section" D="Length" />
  </O>
  <O T="Pile (BB)" X="12-48" Y="1.5*58.75">
    <P N="Batter" V="PileBatter" D="Batter Slope H:V" />
    <P N="Phi" V="PI" D="Batter Orientation" />
    <P N="Beta" V="0" D="Web Orientation" />
    <P N="L" V="384" D="Length" />
    <P N="PileSection" V="pile" T="Section" D="Length" />
  </O>
</O>

```

```

<O T="Pile (BB)" X="12-48+63" Y="-0.5*58.75">
  <P N="Batter" V="PileBatter" D="Batter Slope H:V" />
  <P N="Phi" V="PI" D="Batter Orientation" />
  <P N="Beta" V="0" D="Web Orientation" />
  <P N="L" V="384" D="Length" />
  <P N="PileSection" V="pile" T="Section" D="Length" />
</O>
<O T="Pile (BB)" X="12-48+63" Y="-1.5*58.75">
  <P N="Batter" V="PileBatter" D="Batter Slope H:V" />
  <P N="Phi" V="PI" D="Batter Orientation" />
  <P N="Beta" V="0" D="Web Orientation" />
  <P N="L" V="384" D="Length" />
  <P N="PileSection" V="pile" T="Section" D="Length" />
</O>
<O T="Pile (BB)" X="12-48+63" Y="0.5*58.75">
  <P N="Batter" V="PileBatter" D="Batter Slope H:V" />
  <P N="Phi" V="PI" D="Batter Orientation" />
  <P N="Beta" V="0" D="Web Orientation" />
  <P N="L" V="384" D="Length" />
  <P N="PileSection" V="pile" T="Section" D="Length" />
</O>
<O T="Pile (BB)" X="12-48+63" Y="1.5*58.75">
  <P N="Color" V="##f0000" T="Text" />
  <P N="Batter" V="PileBatter" D="Batter Slope H:V" />
  <P N="Phi" V="PI" D="Batter Orientation" />
  <P N="Beta" V="0" D="Web Orientation" />
  <P N="L" V="384" D="Length" />
  <P N="PileSection" V="pile" T="Section" D="Length" />
</O>
<O T="Pile (BB)" X="12-48+2*63" Y="-0.5*58.75">
  <P N="Batter" V="0" D="Batter Slope H:V" />
  <P N="Phi" V="PI" D="Batter Orientation" />
  <P N="Beta" V="0" D="Web Orientation" />
  <P N="L" V="384" D="Length" />
  <P N="PileSection" V="pile" T="Section" D="Length" />
</O>
<O T="Pile (BB)" X="12-48+2*63" Y="-1.5*58.75">
  <P N="Batter" V="0" D="Batter Slope H:V" />
  <P N="Phi" V="0" D="Batter Orientation" />
  <P N="Beta" V="0" D="Web Orientation" />
  <P N="L" V="384" D="Length" />
  <P N="PileSection" V="pile" T="Section" D="Length" />
</O>
<O T="Pile (BB)" X="12-48+2*63" Y="1.5*58.75">
  <P N="Batter" V="0" D="Batter Slope H:V" />
  <P N="Phi" V="PI" D="Batter Orientation" />
  <P N="Beta" V="0" D="Web Orientation" />
  <P N="L" V="384" D="Length" />
  <P N="PileSection" V="pile" T="Section" D="Length" />
</O>
<O T="Pile (BB)" X="12-48+2*63+36" Y="1.5*58.75" Z="84">
  <P N="Batter" V="PileBatter" D="Batter Slope H:V" />
  <P N="Phi" V="PI/2" D="Batter Orientation" />
  <P N="Beta" V="PI" D="Web Orientation" />
  <P N="L" V="384+84" D="Length" />
  <P N="PileSection" V="pile" T="Section" D="Length" />
</O>

```

```

<O T="Pile (BB)" X="12-48+2*63+36+69" Y="1.5*58.75" Z="84">
  <P N="Batter" V="PileBatter" D="Batter Slope H:V" />
  <P N="Phi" V="PI/2" D="Batter Orientation" />
  <P N="Beta" V="PI" D="Web Orientation" />
  <P N="L" V="384+84" D="Length" />
  <P N="PileSection" V="pile" T="Section" D="Length" />
</O>
<O T="Pile (BB)" X="12-48+2*63+36+2*69" Y="1.5*58.75" Z="84">
  <P N="Batter" V="PileBatter" D="Batter Slope H:V" />
  <P N="Phi" V="PI/2" D="Batter Orientation" />
  <P N="Beta" V="PI" D="Web Orientation" />
  <P N="L" V="384+84" D="Length" />
  <P N="PileSection" V="pile" T="Section" D="Length" />
</O>
<O T="Pile (BB)" X="12-48+2*63+36" Y="1.5*58.75-55.5" Z="84">
  <P N="Batter" V="PileBatter" D="Batter Slope H:V" />
  <P N="Phi" V="PI/2" D="Batter Orientation" />
  <P N="Beta" V="PI" D="Web Orientation" />
  <P N="L" V="384+84" D="Length" />
  <P N="PileSection" V="pile" T="Section" D="Length" />
</O>
<O T="Pile (BB)" X="12-48+2*63+36+69" Y="1.5*58.75-55.5" Z="84">
  <P N="Batter" V="PileBatter" D="Batter Slope H:V" />
  <P N="Phi" V="PI/2" D="Batter Orientation" />
  <P N="Beta" V="0" D="Web Orientation" />
  <P N="L" V="384+84" D="Length" />
  <P N="PileSection" V="pile" T="Section" D="Length" />
</O>
<O T="Pile (BB)" X="12-48+2*63+36+2*69" Y="1.5*58.75-55.5" Z="84">
  <P N="Batter" V="PileBatter" D="Batter Slope H:V" />
  <P N="Phi" V="PI/2" D="Batter Orientation" />
  <P N="Beta" V="0" D="Web Orientation" />
  <P N="L" V="384+84" D="Length" />
  <P N="PileSection" V="pile" T="Section" D="Length" />
</O>
<O T="Pile (BB)" X="12-48+2*63+36+2*69" Y="1.5*58.75-55.5*2" Z="84">
  <P N="Batter" V="0" D="Batter Slope H:V" />
  <P N="Phi" V="PI/2" D="Batter Orientation" />
  <P N="Beta" V="PI/2" D="Web Orientation" />
  <P N="L" V="384+84" D="Length" />
  <P N="PileSection" V="pile" T="Section" D="Length" />
</O>
<O T="Pile (BB)" X="12-48+2*63+36" Y="1.5*58.75-55.5*2" Z="84">
  <P N="Batter" V="0" D="Batter Slope H:V" />
  <P N="Phi" V="PI/2" D="Batter Orientation" />
  <P N="Beta" V="PI/2" D="Web Orientation" />
  <P N="L" V="384+84" D="Length" />
  <P N="PileSection" V="pile" T="Section" D="Length" />
</O>
</O>
<O N="Abut2b Footings" T="Group" RZ="Abut2Skew" AlignH="Orient" AlignV="None" AlignT="None" X="Abut2Sta+12"
Y="-AbutOffset" Z="Abut2WorkPointOffset+1">
  <O T="Rectangular Footing" RZ="PI/2" X="114-54-12-3">
    <P N="Color" V="#D3D3D3" T="Text" />
    <P N="Opacity" V="0.9" />
    <P N="Length" V="260.25" D="Footing Length (Transverse to Bridge Alignment)" />
    <P N="Width" V="204" D="Footing Width (Along Bridge Alignment)" />
  </O>

```

```

    <P N="Depth" V="48" D="Footing Depth" />
    <P N="BotElev" V="-272.04-48" D="Footing Bottom Elevation" />
</O>
<O T="Rectangular Footing" RZ="0" X="132+60" Y="-34">
    <P N="Color" V="#D3D3D3" T="Text" />
    <P N="Opacity" V="0.9" />
    <P N="Length" V="156" D="Footing Length (Transverse to Bridge Alignment)" />
    <P N="Width" V="192" D="Footing Width (Along Bridge Alignment)" />
    <P N="Depth" V="30" D="Footing Depth" />
    <P N="BotElev" V="-272.04" D="Footing Bottom Elevation" />
</O>
</O>
<O N="Abut 2b Piles" T="Group" RZ="Abut2Skew" AlignH="Orient" AlignV="None" AlignT="None" X="Abut2Sta+12"
Y="AbutOffset+109.125*2-24" Z="Abut2WorkPointOffset-272-48+12+1">
    <O T="Pile (BB)" X="12-48" Y="-0*56">
        <P N="Batter" V="PileBatter" D="Batter Slope H:V" />
        <P N="Phi" V="PI" D="Batter Orientation" />
        <P N="Beta" V="0" D="Web Orientation" />
        <P N="L" V="300" D="Length" />
        <P N="PileSection" V="pile" T="Section" />
    </O>
    <O T="Pile (BB)" X="12-48" Y="-1*56">
        <P N="Batter" V="PileBatter" D="Batter Slope H:V" />
        <P N="Phi" V="PI" D="Batter Orientation" />
        <P N="Beta" V="0" D="Web Orientation" />
        <P N="L" V="300" D="Length" />
        <P N="PileSection" V="pile" T="Section" />
    </O>
    <O T="Pile (BB)" X="12-48" Y="-2*56">
        <P N="Batter" V="PileBatter" D="Batter Slope H:V" />
        <P N="Phi" V="PI" D="Batter Orientation" />
        <P N="Beta" V="0" D="Web Orientation" />
        <P N="L" V="300" D="Length" />
        <P N="PileSection" V="pile" T="Section" />
    </O>
    <O T="Pile (BB)" X="12-48" Y="1*56">
        <P N="Batter" V="PileBatter" D="Batter Slope H:V" />
        <P N="Phi" V="PI" D="Batter Orientation" />
        <P N="Beta" V="0" D="Web Orientation" />
        <P N="L" V="300" D="Length" />
        <P N="PileSection" V="pile" T="Section" />
    </O>
    <O T="Pile (BB)" X="12-48" Y="2*56">
        <P N="Batter" V="PileBatter" D="Batter Slope H:V" />
        <P N="Phi" V="PI" D="Batter Orientation" />
        <P N="Beta" V="0" D="Web Orientation" />
        <P N="L" V="300" D="Length" />
        <P N="PileSection" V="pile" T="Section" />
    </O>
    <O T="Pile (BB)" X="12-48+54" Y="-0*56">
        <P N="Batter" V="PileBatter" D="Batter Slope H:V" />
        <P N="Phi" V="PI" D="Batter Orientation" />
        <P N="Beta" V="0" D="Web Orientation" />
        <P N="L" V="300" D="Length" />
        <P N="PileSection" V="pile" T="Section" />
    </O>
    <O T="Pile (BB)" X="12-48+54" Y="-1*56">

```

```

<P N="Batter" V="PileBatter" D="Batter Slope H:V" />
<P N="Phi" V="PI" D="Batter Orientation" />
<P N="Beta" V="0" D="Web Orientation" />
<P N="L" V="300" D="Length" />
<P N="PileSection" V="pile" T="Section" />
</O>
<O T="Pile (BB)" X="12-48+54" Y="-2*56">
  <P N="Batter" V="PileBatter" D="Batter Slope H:V" />
  <P N="Phi" V="PI" D="Batter Orientation" />
  <P N="Beta" V="0" D="Web Orientation" />
  <P N="L" V="300" D="Length" />
  <P N="PileSection" V="pile" T="Section" />
</O>
<O T="Pile (BB)" X="12-48+54" Y="1*56">
  <P N="Batter" V="PileBatter" D="Batter Slope H:V" />
  <P N="Phi" V="PI" D="Batter Orientation" />
  <P N="Beta" V="0" D="Web Orientation" />
  <P N="L" V="300" D="Length" />
  <P N="PileSection" V="pile" T="Section" />
</O>
<O T="Pile (BB)" X="12-48+54" Y="2*56">
  <P N="Batter" V="PileBatter" D="Batter Slope H:V" />
  <P N="Phi" V="PI" D="Batter Orientation" />
  <P N="Beta" V="0" D="Web Orientation" />
  <P N="L" V="300" D="Length" />
  <P N="PileSection" V="pile" T="Section" />
</O>
<O T="Pile (BB)" X="12-48+2*54" Y="0*56">
  <P N="Batter" V="PileBatter" D="Batter Slope H:V" />
  <P N="Phi" V="PI" D="Batter Orientation" />
  <P N="Beta" V="0" D="Web Orientation" />
  <P N="L" V="300" D="Length" />
  <P N="PileSection" V="pile" T="Section" />
</O>
<O T="Pile (BB)" X="12-48+2*54" Y="-2*56">
  <P N="Batter" V="PileBatter" D="Batter Slope H:V" />
  <P N="Phi" V="PI" D="Batter Orientation" />
  <P N="Beta" V="0" D="Web Orientation" />
  <P N="L" V="300" D="Length" />
  <P N="PileSection" V="pile" T="Section" />
</O>
<O T="Pile (BB)" X="12-48+2*54" Y="2*56">
  <P N="Batter" V="PileBatter" D="Batter Slope H:V" />
  <P N="Phi" V="PI" D="Batter Orientation" />
  <P N="Beta" V="0" D="Web Orientation" />
  <P N="L" V="300" D="Length" />
  <P N="PileSection" V="pile" T="Section" />
</O>
<O T="Pile (BB)" X="12-48+3*54" Y="0*56">
  <P N="Batter" V="0" D="Batter Slope H:V" />
  <P N="Phi" V="PI" D="Batter Orientation" />
  <P N="Beta" V="0" D="Web Orientation" />
  <P N="L" V="300" D="Length" />
  <P N="PileSection" V="pile" T="Section" />
</O>
<O T="Pile (BB)" X="12-48+3*54" Y="-2*56">
  <P N="Batter" V="0" D="Batter Slope H:V" />

```

```

<P N="Phi" V="PI" D="Batter Orientation" />
<P N="Beta" V="0" D="Web Orientation" />
<P N="L" V="300" D="Length" />
<P N="PileSection" V="pile" T="Section" />
</O>
<O T="Pile (BB)" X="12-48+3*54" Y="2*56">
  <P N="Batter" V="0" D="Batter Slope H:V" />
  <P N="Phi" V="PI" D="Batter Orientation" />
  <P N="Beta" V="0" D="Web Orientation" />
  <P N="L" V="300" D="Length" />
  <P N="PileSection" V="pile" T="Section" />
</O>
<O T="Pile (BB)" X="12-48+3*54+36" Y="-2*56" Z="48">
  <P N="Batter" V="PileBatter" D="Batter Slope H:V" />
  <P N="Phi" V="-PI/2" D="Batter Orientation" />
  <P N="Beta" V="PI" D="Web Orientation" />
  <P N="L" V="300+48" D="Length" />
  <P N="PileSection" V="pile" T="Section" />
</O>
<O T="Pile (BB)" X="12-48+3*54+36+48" Y="-2*56" Z="48">
  <P N="Batter" V="PileBatter" D="Batter Slope H:V" />
  <P N="Phi" V="-PI/2" D="Batter Orientation" />
  <P N="Beta" V="PI" D="Web Orientation" />
  <P N="L" V="300+48" D="Length" />
  <P N="PileSection" V="pile" T="Section" />
</O>
<O T="Pile (BB)" X="12-48+3*54+36+48*2" Y="-2*56" Z="48">
  <P N="Batter" V="PileBatter" D="Batter Slope H:V" />
  <P N="Phi" V="-PI/2" D="Batter Orientation" />
  <P N="Beta" V="PI" D="Web Orientation" />
  <P N="L" V="300+48" D="Length" />
  <P N="PileSection" V="pile" T="Section" />
</O>
<O T="Pile (BB)" X="12-48+3*54+36" Y="-2*56+78" Z="48">
  <P N="Batter" V="PileBatter" D="Batter Slope H:V" />
  <P N="Phi" V="-PI/2" D="Batter Orientation" />
  <P N="Beta" V="PI" D="Web Orientation" />
  <P N="L" V="300+48" D="Length" />
  <P N="PileSection" V="pile" T="Section" />
</O>
<O T="Pile (BB)" X="12-48+3*54+36+48" Y="-2*56+78" Z="48">
  <P N="Batter" V="PileBatter" D="Batter Slope H:V" />
  <P N="Phi" V="-PI/2" D="Batter Orientation" />
  <P N="Beta" V="PI" D="Web Orientation" />
  <P N="L" V="300+48" D="Length" />
  <P N="PileSection" V="pile" T="Section" />
</O>
<O T="Pile (BB)" X="12-48+3*54+36+48*2" Y="-2*56+78" Z="48">
  <P N="Batter" V="PileBatter" D="Batter Slope H:V" />
  <P N="Phi" V="-PI/2" D="Batter Orientation" />
  <P N="Beta" V="PI" D="Web Orientation" />
  <P N="L" V="300+48" D="Length" />
  <P N="PileSection" V="pile" T="Section" />
</O>
<O T="Pile (BB)" X="12-48+3*54+36" Y="-2*56+78*2" Z="48">
  <P N="Batter" V="0" D="Batter Slope H:V" />
  <P N="Phi" V="-PI/2" D="Batter Orientation" />

```



```

    <P N="Beta" V="PI/2" D="Web Orientation" />
    <P N="L" V="300+48" D="Length" />
    <P N="PileSection" V="pile" T="Section" />
  </O>
  <O T="Pile (BB)" X="12-48+3*54+36+48*2" Y="-2*56+78*2" Z="48">
    <P N="Batter" V="0" D="Batter Slope H:V" />
    <P N="Phi" V="-PI/2" D="Batter Orientation" />
    <P N="Beta" V="PI/2" D="Web Orientation" />
    <P N="L" V="300+48" D="Length" />
    <P N="PileSection" V="pile" T="Section" />
  </O>
</O>
  <O N="Wing Walls" T="Group" RZ="Abut2Skew" AlignH="Orient" AlignV="None" AlignT="None" X="Abut2Sta+12" Y="-
AbutOffset-109.125" Z="Abut2WorkPointOffset+1">
  <O T="Wing Wall (BB)" X="81" Y="2*109.125-39/2" Z="-206.04+54+30-5" RZ="0">
    <P N="Color" V="#D3D3D3" T="Text" />
    <P N="Opacity" V="0.9" />
    <P N="Length" V="198" D="Total Wall Longitudinal Length" />
    <P N="DistanceToCrown" V="198" D="Distance from left side to Crown" />
    <P N="Base_Width" V="39" D="Wall Width at Base" />
    <P N="Top_Width" V="1/12" D="Ratio of Wall Width at Top to Height" />
    <P N="Top_Wall_Height" V="(9.12/239.5)*51+210+8.5" D="Height of wall at higher end" />
    <P N="Crown_Height" V="9.12+210+8.5" D="Height of wall at crown" />
    <P N="Lower_Wall_Height" V="9.12+210+7.5" D="Height of wall at lower end" />
    <P N="Skew" V="0" D="Skew angle of end of wall" />
    <P N="Slope" V="1" D="Wall sloped to the '1' for Right or '2' for Left" />
    <P N="rSlope" V="0.0988" D="Slope of rail on top of wall." Role="Input" Category="WingWallData" />
  </O>
  <O T="Wing Wall (BB)" Y="-2*109.125+48/2" Z="-272.04+30-5" RZ="0" X="114">
    <P N="Color" V="#D3D3D3" T="Text" />
    <P N="Opacity" V="0.9" />
    <P N="Length" V="155.5" D="Total Wall Longitudinal Length" />
    <P N="DistanceToCrown" V="155.5" D="Distance from left side to Crown" />
    <P N="Base_Width" V="48" D="Wall Width at Base" />
    <P N="Top_Width" V="1/12" D="Ratio of Wall Width at Top to Height" />
    <P N="Top_Wall_Height" V="(10.68/239.5)*84+322.8+8.5" D="Height of wall at higher end" />
    <P N="Crown_Height" V="10.68+322.8+8" D="Height of wall at crown" />
    <P N="Lower_Wall_Height" V="10.68+322.8+7.5" D="Height of wall at lower end" />
    <P N="Skew" V="0" D="Skew angle of end of wall" />
    <P N="Slope" V="2" D="Wall sloped to the '1' for Right or '2' for Left" />
    <P N="rSlope" V="0.0988" D="Slope of rail on top of wall." Role="Input" Category="WingWallData" />
  </O>
</O>
  <O N="Step Footing WingWall C" T="Group" RZ="Abut2Skew" AlignH="Orient" AlignV="None" AlignT="None"
X="Abut2Sta+12" Y="AbutOffset" Z="Abut2WorkPointOffset">
  <O T="Rectangular Footing" RZ="0" X="9*12-15" Y="-2*109.125+147/2-13" Z="2">
    <P N="Color" V="#D3D3D3" T="Text" />
    <P N="Opacity" V="0.9" />
    <P N="Length" V="24" D="Footing Length (Transverse to Bridge Alignment)" />
    <P N="Width" V="147" D="Footing Width (Along Bridge Alignment)" />
    <P N="Depth" V="54" D="Footing Depth" />
    <P N="BotElev" V="-272.04+36+24" D="Footing Bottom Elevation" />
  </O>
</O>
  <O N="Step Footing Abut West" T="Group" RZ="Abut2Skew" AlignH="Orient" AlignV="None" AlignT="None"
X="Abut2Sta+12" Y="-AbutOffset" Z="Abut2WorkPointOffset">
  <O T="Rectangular Footing" RZ="0" X="24" Y="-109.125-10.5">

```

```

    <P N="Color" V="#D3D3D3" T="Text" />
    <P N="Opacity" V="0.9" />
    <P N="Length" V="162" D="Footing Length (Transverse to Bridge Alignment)" />
    <P N="Width" V="21" D="Footing Width (Along Bridge Alignment)" />
    <P N="Depth" V="36" D="Footing Depth" />
    <P N="BotElev" V="-272.04" D="Footing Bottom Elevation" />
  </O>
</O>
<O N="Short Wing Walls" T="Group" RZ="Abut2Skew" AlignH="Orient" AlignV="None" AlignT="None"
X="Abut2Sta+12" Y="-AbutOffset-109.125" Z="Abut2WorkPointOffset+1">
  <O T="Wing Wall (BB)" X="30" Y="2*109.125-46/2" Z="-206.04-5" RZ="0">
    <P N="Color" V="#D3D3D3" T="Text" />
    <P N="Opacity" V="0.9" />
    <P N="Length" V="51" D="Total Wall Longitudinal Length" />
    <P N="DistanceToCrown" V="51" D="Distance from left side to Crown" />
    <P N="Base_Width" V="46" D="Wall Width at Base" />
    <P N="Top_Width" V="1/12" D="Ratio of Wall Width at Top to Height" />
    <P N="Top_Wall_Height" V="210+30+54+12.5" D="Height of wall at higher end" />
    <P N="Crown_Height" V="(9.12/239.5)*51+210+30+54+12.5" D="Height of wall at crown" />
    <P N="Lower_Wall_Height" V="(9.12/239.5)*51+210+30+54+12.5" D="Height of wall at lower end" />
    <P N="Skew" V="0" D="Skew angle of end of wall" />
    <P N="Slope" V="1" D="Wall sloped to the '1' for Right or '2' for Left" />
    <P N="rSlope" V="0.0988" D="Slope of rail on top of wall." Role="Input" Category="WingWallData" />
  </O>
  <O T="Wing Wall (BB)" Y="-2*109.125+51/2" Z="-272.04-5" RZ="0" X="30">
    <P N="Color" V="#D3D3D3" T="Text" />
    <P N="Opacity" V="0.9" />
    <P N="Length" V="84" D="Total Wall Longitudinal Length" />
    <P N="DistanceToCrown" V="84" D="Distance from left side to Crown" />
    <P N="Base_Width" V="51" D="Wall Width at Base" />
    <P N="Top_Width" V="1/12" D="Ratio of Wall Width at Top to Height" />
    <P N="Top_Wall_Height" V="322.8+30+12.5" D="Height of wall at higher end" />
    <P N="Crown_Height" V="(10.68/239.5)*84+322.8+30+12.5" D="Height of wall at crown" />
    <P N="Lower_Wall_Height" V="(10.68/239.5)*84+322.8+30+12.5" D="Height of wall at lower end" />
    <P N="Skew" V="0" D="Skew angle of end of wall" />
    <P N="Slope" V="2" D="Wall sloped to the '1' for Right or '2' for Left" />
    <P N="rSlope" V="0.0988" D="Slope of rail on top of wall." Role="Input" Category="WingWallData" />
  </O>
</O>
</O>
<O N="Bridge Rail" T="Group" AlignH="Warp" AlignV="Warp" X="Abut2Sta+12" Y="0" Z="-0.75">
  <O T="PA Turnpike Barrier New" X="6">
    <P N="Station" V="0" />
    <P N="Length" V="239.5+24" />
    <P N="Offset" V="144" />
    <P N="type" V="RIGHT" />
  </O>
  <O T="PA Turnpike Barrier New" X="6">
    <P N="Station" V="0" />
    <P N="Length" V="249+24" />
    <P N="Offset" V="-252" />
    <P N="type" V="LEFT" />
  </O>
</O>
</O>
</O>
</O>
<O N="Piers" T="Group">
  <O N="Column and Foundation Data" T="Group">

```

```

<P N="EndUserInputFields" V="1" />
<P N="Pier1Sta" V="75060" D="" />
<P N="Pier2Sta" V="77220" D="" />
<P N="Pier1Height" V="25.48*12" D="" />
<P N="Pier2Height" V="41.6*12" D="" />
<P N="PierOffset" V="-54" D="" />
<P N="CIDH_Space" V="81" D="" />
<P N="ColumnH" V="60" D="" />
<P N="ColumnV" V="120" D="" />
<P N="FootT" V="48" D="" />
<P N="FootV" V="246" D="" />
<P N="FootL" V="84" D="" />
<P N="Pier1WorkPoint" V="alignT(CSAlignment,Pier1Sta,PierOffset)-80.375-8.6875" D="" />
<P N="Pier2WorkPoint" V="alignT(CSAlignment,Pier2Sta,PierOffset)-80.375-6.5" D="" />
<P N="CIDHDia" V="54" D="" />
<P N="CIDHLength" V="168" D="" />
<O N="circ" T="Section">
  <O T="Circle">
    <P N="Radius" V="CIDHDia/2" />
  </O>
</O>
</O>
<O N="Pier1" T="Group" X="Pier1Sta" Y="PierOffset" Z="Pier1WorkPoint">
  <O T="Hammerhead Pier Cap (BB)" Z="-20.25" AlignH="Orient" AlignV="None" AlignT="None">
    <P N="PierLength" V="436" D="Total Pier Length" Category="PierData" />
    <P N="PierWidth" V="60" D="Pier Width" Category="PierData" />
    <P N="DistanceToCrown" V="54" D="Distance from Left edge to Crown" />
    <P N="MinD_R" V="56" D="Left Min Depth" />
    <P N="ColumnExt" V="56" D="Upper part of column" />
    <P N="ColumnRadius" V="55." D="Radius from Pier Cap to Colum" />
    <P N="ExtensionL" V="158" D="Left Sloped Section" />
    <P N="ExtensionR" V="158" D="Right Sloped Section" />
    <P N="MinD_L" V="56" D="Right Min Depth" />
    <P N="MaxD_L" V="106" D="Right Max Depth" />
    <P N="EndUserInputFields" V="1" />
    <P N="Color" V="#D3D3D3" T="Text" />
    <P N="PedestalLocations1" V="[-171, -57, 57, 171]" />
    <P N="PedestalOffset" V="0" />
    <P N="PCrossSlopeL" V="-0.0688" D="Cross Slope to left of Crown" />
    <P N="PCrossSlopeR" V="0.0688" D="Cross Slope to Right of Crown" />
    <P N="PedestalDepth" V="[4.82,7.41,6.15,4.90]" />
    <P N="PedestalTopWidth" V="56" D="Top Width of the Girder Supports" />
    <P N="PedestalBotWidth" V="56" D="Bottom Width of the Girder Supports" />
    <P N="PedestalL1" V="34" D="Length of Girder Support 1" />
  </O>
  <O N="Pot Bearings" T="Group" AlignH="Orient" AlignV="None" AlignT="None" Z="-16.5">
    <P N="potlocs" V="PedestalLocations1" />
    <P N="SupportSlope" V="-0.0688" />
    <O T="Pot Bearing" X="0" Y="potlocs[0]" Z="-potlocs[0]*SupportSlope+4.90">
      <P N="w" V="21.75" D="Width of the masonry plate (B), in." Role="Input" />
      <P N="h" V="45" D="Length of the masonry plate (C), in." Role="Input" />
      <P N="t" V="3.5" D="Thickness of the masonry plate (A), in." Role="Input" />
      <P N="D" V="19.125" D="Distance of bolt holes from CL (D), in." Role="Input" />
      <P N="r" V="1.25" D="Radius of bolt holes, in." Role="Input" />
      <P N="c" V="-2.5625" D="Depth of piston compression (to match girder elevation), in." Role="Input" />
      <P N="Sta" V="Pier1Sta" />
    </O>
  </O>
</O>

```

```

<O T="Pot Bearing" X="0" Y="potlocs[1]" Z="-potlocs[1]*SupportSlope+6.15">
  <P N="w" V="21.75" D="Width of the masonry plate (B), in." Role="Input" />
  <P N="h" V="45" D="Length of the masonry plate (C), in." Role="Input" />
  <P N="t" V="3.5" D="Thickness of the masonry plate (A), in." Role="Input" />
  <P N="D" V="19.125" D="Distance of bolt holes from CL (D), in." Role="Input" />
  <P N="r" V="1.25" D="Radius of bolt holes, in." Role="Input" />
  <P N="c" V="-2.5625" D="Depth of piston compression (to match girder elevation), in." Role="Input" />
  <P N="Sta" V="Pier1Sta" />
</O>
<O T="Pot Bearing" X="0" Y="potlocs[2]" Z="-potlocs[2]*SupportSlope+7.41">
  <P N="w" V="21.75" D="Width of the masonry plate (B), in." Role="Input" />
  <P N="h" V="45" D="Length of the masonry plate (C), in." Role="Input" />
  <P N="t" V="3.5" D="Thickness of the masonry plate (A), in." Role="Input" />
  <P N="D" V="19.125" D="Distance of bolt holes from CL (D), in." Role="Input" />
  <P N="r" V="1.25" D="Radius of bolt holes, in." Role="Input" />
  <P N="c" V="-2.5625" D="Depth of piston compression (to match girder elevation), in." Role="Input" />
  <P N="Sta" V="Pier1Sta" />
</O>
<O T="Pot Bearing" X="0" Y="potlocs[3]" Z="-potlocs[3]*SupportSlope+4.82">
  <P N="w" V="21.75" D="Width of the masonry plate (B), in." Role="Input" />
  <P N="h" V="45" D="Length of the masonry plate (C), in." Role="Input" />
  <P N="t" V="3.5" D="Thickness of the masonry plate (A), in." Role="Input" />
  <P N="D" V="19.125" D="Distance of bolt holes from CL (D), in." Role="Input" />
  <P N="r" V="1.25" D="Radius of bolt holes, in." Role="Input" />
  <P N="c" V="-2.5625" D="Depth of piston compression (to match girder elevation), in." Role="Input" />
  <P N="Sta" V="Pier1Sta" />
</O>
</O>
<O T="Rectangular Column" AlignH="Orient" AlignV="None" AlignT="None">
  <P N="Color" V="#D3D3D3" T="Text" />
  <P N="Depth" V="ColumnH" D="Column Depth (Along Bridge Alignment)" />
  <P N="Width" V="ColumnV" D="Column Width (Transverse to Bridge Alignment)" />
  <P N="TopElev" V="Pier1WorkPoint-95" D="Column Top Elevation" />
  <P N="BotElev" V="Pier1WorkPoint-Pier1Height" D="Column Bottom Elevation" />
</O>
<O T="Rectangular Footing" AlignH="Orient" AlignV="None" AlignT="None">
  <P N="Color" V="#D3D3D3" T="Text" />
  <P N="Length" V="Piers.FootL" D="Footing Length (Along Bridge Alignment)" />
  <P N="Width" V="Piers.FootV" D="Footing Width (Transverse to Bridge Alignment)" />
  <P N="Depth" V="Piers.FootT" D="Footing Depth" />
  <P N="BotElev" V="Pier1WorkPoint-Pier1Height-Piers.FootT" D="Footing Bottom Elevation" />
</O>
<O N="Piles" T="Group" AlignH="Orient" AlignV="None" AlignT="None">
  <O T="Volume">
    <P N="Color" V="#D3D3D3" T="Text" />
    <P N="Opacity" V="0.9" />
    <P N="Section" V="circ" T="Section" />
    <O T="Point" Y="CIDH_Space" Z="Pier1WorkPoint-Pier1Height-Piers.FootT" X="0" />
    <O T="Point" Y="CIDH_Space" Z="Pier1WorkPoint-Pier1Height-Piers.FootT-CIDHLength" X="0" />
  </O>
  <O T="Volume">
    <P N="Color" V="#D3D3D3" T="Text" />
    <P N="Opacity" V="0.9" />
    <P N="Section" V="circ" T="Section" />
    <O T="Point" Y="-CIDH_Space" Z="Pier1WorkPoint-Pier1Height-Piers.FootT" X="0" />
    <O T="Point" Y="-CIDH_Space" Z="Pier1WorkPoint-Pier1Height-Piers.FootT-CIDHLength" X="0" />
  </O>
</O>

```

```

</O>
</O>
<O N="Pier2" T="Group" X="Pier2Sta" Y="PierOffset" Z="Pier2WorkPoint" AlignH="Orient" AlignV="None"
AlignT="None">
  <O T="Hammerhead Pier Cap (BB)" RZ="0" Z="-14.5">
    <P N="EndUserInputFields" V="1" />
    <P N="PierLength" V="436" D="Total Pier Length" Category="PierData" />
    <P N="PierWidth" V="60" D="Pier Width" Category="PierData" />
    <P N="DistanceToCrown" V="54" D="Distance from Left edge to Crown" />
    <P N="MinD_R" V="60" D="Left Min Depth" />
    <P N="MaxD_R" V="131" D="Left Max Depth" />
    <P N="ColumnExt" V="50" D="Upper part of column" />
    <P N="ColumnRadius" V="55" D="Radius from Pier Cap to Colum" />
    <P N="ExtensionL" V="158" D="Left Sloped Section" />
    <P N="ExtensionR" V="158" D="Right Sloped Section" />
    <P N="MinD_L" V="60" D="Right Min Depth" />
    <P N="MaxD_L" V="110" D="Right Max Depth" />
    <P N="Color" V="#D3D3D3" T="Text" />
    <P N="PedestalLocations1" V="[-171, -57, 57, 171]" />
    <P N="PedestalOffset" V="0" />
    <P N="PCrossSlopeL" V="-0.05367" D="Cross Slope to left of Crown" />
    <P N="PCrossSlopeR" V="0.05367" D="Cross Slope to Right of Crown" />
    <P N="PedestalDepth" V="[4.31,6.59,5.51,4.30]" />
    <P N="PedestalTopWidth" V="48" D="Top Width of the Girder Supports" />
    <P N="PedestalBotWidth" V="48" D="Bottom Width of the Girder Supports" />
    <P N="PedestalL1" V="34" D="Length of Girder Support 1" />
  </O>
  <O N="Pot Bearings" T="Group" AlignH="Orient" AlignV="None" AlignT="None" Z="-11.5">
    <P N="potlocs" V="PedestalLocations1" />
    <P N="SupportSlope" V="-0.05367" />
    <O T="Pot Bearing" X="0" Y="potlocs[0]" Z="-potlocs[0]*-.05367+4.31">
      <P N="w" V="21.75" D="Width of the masonry plate (B), in." Role="Input" />
      <P N="h" V="32" D="Length of the masonry plate (C), in." Role="Input" />
      <P N="t" V="2.75" D="Thickness of the masonry plate (A), in." Role="Input" />
      <P N="D" V="13.75" D="Distance of bolt holes from CL (D), in." Role="Input" />
      <P N="r" V="0.875" D="Radius of bolt holes, in." Role="Input" />
      <P N="c" V="1.9375" D="Depth of piston compression (to match girder elevation), in." Role="Input" />
      <P N="Sta" V="Pier2Sta" D="x-Station" Role="Input" Category="Parameters" />
    </O>
    <O T="Pot Bearing" X="0" Y="potlocs[1]" Z="-potlocs[1]*-.05367+5.51">
      <P N="w" V="21.75" D="Width of the masonry plate (B), in." Role="Input" />
      <P N="h" V="32" D="Length of the masonry plate (C), in." Role="Input" />
      <P N="t" V="2.75" D="Thickness of the masonry plate (A), in." Role="Input" />
      <P N="D" V="13.75" D="Distance of bolt holes from CL (D), in." Role="Input" />
      <P N="r" V="0.875" D="Radius of bolt holes, in." Role="Input" />
      <P N="c" V="1.9375" D="Depth of piston compression (to match girder elevation), in." Role="Input" />
      <P N="Sta" V="Pier2Sta" D="x-Station" Role="Input" Category="Parameters" />
    </O>
    <O T="Pot Bearing" X="0" Y="potlocs[2]" Z="-potlocs[2]*-.05367+6.59">
      <P N="w" V="21.75" D="Width of the masonry plate (B), in." Role="Input" />
      <P N="h" V="32" D="Length of the masonry plate (C), in." Role="Input" />
      <P N="t" V="2.75" D="Thickness of the masonry plate (A), in." Role="Input" />
      <P N="D" V="13.75" D="Distance of bolt holes from CL (D), in." Role="Input" />
      <P N="r" V="0.875" D="Radius of bolt holes, in." Role="Input" />
      <P N="c" V="1.9375" D="Depth of piston compression (to match girder elevation), in." Role="Input" />
      <P N="Sta" V="Pier2Sta" D="x-Station" Role="Input" Category="Parameters" />
    </O>
  </O>

```

```

<O T="Pot Bearing" X="0" Y="potlocs[3]" Z="-potlocs[3]*-.05367+4.30">
  <P N="w" V="21.75" D="Width of the masonry plate (B), in." Role="Input" />
  <P N="h" V="32" D="Length of the masonry plate (C), in." Role="Input" />
  <P N="t" V="2.75" D="Thickness of the masonry plate (A), in." Role="Input" />
  <P N="D" V="13.75" D="Distance of bolt holes from CL (D), in." Role="Input" />
  <P N="r" V="0.875" D="Radius of bolt holes, in." Role="Input" />
  <P N="c" V="1.9375" D="Depth of piston compression (to match girder elevation), in." Role="Input" />
  <P N="Sta" V="Pier2Sta" D="x-Station" Role="Input" Category="Parameters" />
</O>
</O>
<O T="Rectangular Column" AlignH="Orient" AlignV="None" AlignT="None" RZ="0">
  <P N="Color" V="#D3D3D3" T="Text" />
  <P N="Depth" V="ColumnH" D="Column Depth (Along Bridge Alignment)" />
  <P N="Width" V="ColumnV" D="Column Width (Transverse to Bridge Alignment)" />
  <P N="TopElev" V="Pier2WorkPoint-95" D="Column Top Elevation" />
  <P N="BotElev" V="Pier2WorkPoint-Pier2Height" D="Column Bottom Elevation" />
</O>
<O T="Rectangular Footing" AlignH="Orient" AlignV="None" AlignT="None" RZ="0">
  <P N="Color" V="#D3D3D3" T="Text" />
  <P N="Length" V="Piers.FootL" D="Footing Length (Along Bridge Alignment)" />
  <P N="Width" V="Piers.FootV" D="Footing Width (Transverse to Bridge Alignment)" />
  <P N="Depth" V="Piers.FootT" D="Footing Depth" />
  <P N="BotElev" V="Pier2WorkPoint-Pier2Height-Piers.FootT" D="Footing Bottom Elevation" />
</O>
<O N="Piles" T="Group" AlignH="Orient" AlignV="None" AlignT="None">
  <O T="Volume">
    <P N="Color" V="#D3D3D3" T="Text" />
    <P N="Opacity" V="0.9" />
    <P N="Section" V="circ" T="Section" />
    <O T="Point" Y="CIDH_Space" Z="Pier2WorkPoint-Pier2Height-Piers.FootT" X="0" />
    <O T="Point" Y="CIDH_Space" Z="Pier2WorkPoint-Pier2Height-Piers.FootT-CIDHLength" X="0" />
  </O>
  <O T="Volume">
    <P N="Color" V="#D3D3D3" T="Text" />
    <P N="Opacity" V="0.9" />
    <P N="Section" V="circ" T="Section" />
    <O T="Point" Y="-CIDH_Space" Z="Pier2WorkPoint-Pier2Height-Piers.FootT" X="0" />
    <O T="Point" Y="-CIDH_Space" Z="Pier2WorkPoint-Pier2Height-Piers.FootT-CIDHLength" X="0" />
  </O>
</O>
</O>
</O>
<O N="Superstructure" T="Group">
  <O N="Girders" T="Group">
    <P N="Color" V="#991111" T="Text" />
    <P N="Opacity" V="0.7" />
    <O N="Girder 1" T="Group">
      <O N="G1FS1" T="SteelGirderMB" Z="-12.5" Y="117" X="BridgeLayoutData.Abut1Sta-13" AlignV="Warp"
AlignH="Warp" AlignT="None">
        <P N="StartStation" V="G1FS1.X" />
        <P N="Offset" V="G1FS1.Y" />
        <P N="Length" V="1033" />
        <P N="dw" V="66" D="Web depth of the I girder" />
        <P N="tw" V="0.6875" D="Web thickness of the I girder" />
        <P N="bft" V="18" D="Width of the top flange of the I girder" />
        <P N="tft" V="0.875" D="Thickness of the top flange of the I girder" />

```

```

<P N="bfb" V="20" D="Width of the bottom flange of the I girder" />
<P N="tfb" V="1" D="Thickness of the bottom flange of the I girder" />
<O N="StiffenerData" T="Group">
  <P N="WebStiffOrient" V="L" T="Text" D="Side of Web stiffened, L= Left, R = Right, B = Both, N = None" />
  <P N="WebStiffLoc" V="[73, 133, 193, 313, 373, 433, 553, 613, 673, 793, 853, 913, 1033]" D="StiffenerLocations"
/>
  <P N="WebStiffT" V="0.625" D="Shear Stiffener Plate Thickness" />
  <P N="WebStiffW" V="6" D="Shear Stiffener Plate Width" />
  <P N="WebStiffHeight" V="dw" D="Shear Stiffener Height" />
  <P N="WebStiffClipH" V="1.5" D="Shear Stiffener Horizontal Clip" />
  <P N="WebStiffClipV" V="2.5" D="Shear Stiffener Vertical Clip" />
  <P N="ConnStiffOrient" V="L" T="Text" D="Side of Web stiffened, L= Left, R = Right, B = Both, N = None" />
  <P N="ConnStiffLoc" V="[253, 493, 733, 973]" D="Connector Stiffener Locations" />
  <P N="ConnStiffT" V="0.75" D="Connection Stiffener Thickness" />
  <P N="ConnStiffW" V="8" D="Connector Plate Width" />
  <P N="ConnStiffHeight" V="dw" D="Connection Stiffener Height" />
  <P N="ConnStiffClipH" V="1.5" D="Connection Stiffener Horizontal Clip" />
  <P N="ConnStiffClipV" V="2.5" D="Connection Stiffener Vertical Clip" />
  <P N="BearingStiffOrient" V="B" T="Text" D="Side of Web stiffened, L= Left, R = Right, B = Both, N = None" />
  <P N="BearingStiffLoc" V="[13]" D="Bearing Stiffener Locations" />
  <P N="BearingStiffT" V="0.75" D="Bearing Stiffener Thickness" />
  <P N="BearingStiffW" V="7.5" D="Bearing Plate Width" />
  <P N="BearingStiffHeight" V="dw" D="Bearing Stiffener Height" />
  <P N="BearingStiffClipH" V="1.5" D="Bearing Stiffener Horizontal Clip" />
  <P N="BearingStiffClipV" V="2.5" D="Bearing Stiffener Vertical Clip" />
  <P N="JackingStiffOrient" V="N" T="Text" D="Side of Web stiffened, L= Left, R = Right, B = Both, N = None" />
  <P N="JackingStiffT" V="1" D="Jacking Stiffener Thickness" />
  <P N="JackingStiffW" V="9" D="Jacking Plate Width" />
  <P N="JackingStiffHeight" V="dw" D="Jacking Stiffener Height" />
  <P N="JackingStiffClipH" V="1.5" D="Jacking Stiffener Horizontal Clip" />
  <P N="JackingStiffClipV" V="2.5" D="Jacking Stiffener Vertical Clip" />
</O>
</O>
<O N="G1FS2" T="SteelGirderMB" AlignH="Warp" AlignV="Warp" AlignT="None" X="74520" Y="117" Z="-12.5">
  <P N="StartStation" V="G1FS2.X" />
  <P N="Offset" V="G1FS2.Y" />
  <P N="Length" V="1056" />
  <P N="dw" V="66" D="Web depth of the I girder" />
  <P N="tw" V="0.6875" D="Web thickness of the I girder" />
  <P N="bft" V="20" D="Width of the top flange of the I girder" />
  <P N="tft" V="[0,348], 1.125,[348,711], 2.25,[711,1056], 1.125]" D="Thickness of the top flange of the I girder" />
  <P N="bfb" V="20" D="Width of the bottom flange of the I girder" />
  <P N="tfb" V="[0,348], 1.5,[348,711], 2.75,[711,1056], 1.5]" D="Thickness of the bottom flange of the I girder" />
  <O N="StiffenerData" T="Group">
    <P N="WebStiffOrient" V="L" T="Text" D="Side of Web stiffened, L= Left, R = Right, B = Both" />
    <P N="WebStiffLoc" V="[60, 120, 240, 300, 420, 480, 600, 660, 780, 840, 960, 1020,]" D="StiffenerLocations" />
    <P N="WebStiffT" V="0.625" D="Shear Stiffener Plate Thickness" />
    <P N="WebStiffW" V="6" D="Shear Stiffener Plate Width" />
    <P N="WebStiffHeight" V="dw" D="Shear Stiffener Height" />
    <P N="WebStiffClipH" V="1.5" D="Shear Stiffener Horizontal Clip" />
    <P N="WebStiffClipV" V="2.5" D="Shear Stiffener Vertical Clip" />
    <P N="ConnStiffOrient" V="L" T="Text" D="Side of Web stiffened, L= Left, R = Right, B = Both" />
    <P N="ConnStiffLoc" V="[180, 360, 720, 900]" D="Connector Stiffener Locations" />
    <P N="ConnStiffT" V="0.75" D="Connection Stiffener Thickness" />
    <P N="ConnStiffW" V="8" D="Connector Plate Width" />
    <P N="ConnStiffHeight" V="dw" D="Connection Stiffener Height" />
    <P N="ConnStiffClipH" V="1.5" D="Connection Stiffener Horizontal Clip" />
  </O>
</O>

```

```

    <P N="ConnStiffClipV" V="2.5" D="Connection Stiffener Vertical Clip" />
    <P N="BearingStiffOrient" V="B" T="Text" D="Side of Web stiffened, L= Left, R = Right, B = Both, N = None" />
    <P N="BearingStiffLoc" V="[540]" D="Bearing Stiffener locations" />
    <P N="BearingStiffT" V="1" D="Bearing Stiffener Thickness" />
    <P N="BearingStiffW" V="9" D="Bearing Plate Width" />
    <P N="BearingStiffHeight" V="dw" D="Bearing Stiffener Height" />
    <P N="BearingStiffClipH" V="1.5" D="Bearing Stiffener Horizontal Clip" />
    <P N="BearingStiffClipV" V="2.5" D="Bearing Stiffener Vertical Clip" />
    <P N="JackingStiffOrient" V="B" T="Text" D="Side of Web stiffened, L= Left, R = Right, B = Both, N = None" />
    <P N="JackingStiffLoc" V="[516,564]" D="Jacking Stiffener locations" />
    <P N="JackingStiffT" V="1" D="Jacking Stiffener Thickness" />
    <P N="JackingStiffW" V="9" D="Jacking Plate Width" />
    <P N="JackingStiffHeight" V="dw" D="Jacking Stiffener Height" />
    <P N="JackingStiffClipH" V="1.5" D="Jacking Stiffener Horizontal Clip" />
    <P N="JackingStiffClipV" V="2.5" D="Jacking Stiffener Vertical Clip" />
  </O>
</O>
<O N="G1FS3" T="SteelGirderMB" AlignH="Warp" AlignV="Warp" AlignT="None" X="75576" Y="117" Z="-12.5">
  <P N="StartStation" V="G1FS3.X" />
  <P N="Offset" V="G1FS3.Y" />
  <P N="Length" V="1128" />
  <P N="dw" V="66" D="Web depth of the I girder" />
  <P N="tw" V="0.6875" D="Web thickness of the I girder" />
  <P N="bft" V="18" D="Width of the top flange of the I girder" />
  <P N="tft" V="0.875" D="Thickness of the top flange of the I girder" />
  <P N="bfb" V="20" D="Width of the bottom flange of the I girder" />
  <P N="tfb" V="1.375" D="Thickness of the bottom flange of the I girder" />
  <O N="Stiffener Data" T="Group">
    <P N="WebStiffOrient" V="L" T="Text" D="Side of Web stiffened, L= Left, R = Right, B = Both" />
    <P N="WebStiffLoc" V="[24, 144, 204, 264, 384, 444, 504, 624, 684, 744, 864, 924, 984, 1104]" D="Stiffener
locations" />
    <P N="WebStiffT" V="0.625" D="Shear Stiffener Plate Thickness" />
    <P N="WebStiffW" V="6" D="Shear Stiffener Plate Width" />
    <P N="WebStiffHeight" V="dw" D="Shear Stiffener Height" />
    <P N="WebStiffClipH" V="1.5" D="Shear Stiffener Horizontal Clip" />
    <P N="WebStiffClipV" V="2.5" D="Shear Stiffener Vertical Clip" />
    <P N="ConnStiffOrient" V="L" T="Text" D="Side of Web stiffened, L= Left, R = Right, B = Both" />
    <P N="ConnStiffLoc" V="[84, 324, 564, 804, 1044]" D="Connector Stiffener locations" />
    <P N="ConnStiffT" V="0.75" D="Connection Stiffener Thickness" />
    <P N="ConnStiffW" V="8" D="Connector Plate Width" />
    <P N="ConnStiffHeight" V="dw" D="Connection Stiffener Height" />
    <P N="ConnStiffClipH" V="1.5" D="Connection Stiffener Horizontal Clip" />
    <P N="ConnStiffClipV" V="2.5" D="Connection Stiffener Vertical Clip" />
    <P N="BearingStiffOrient" V="N" T="Text" D="Side of Web stiffened, L= Left, R = Right, B = Both, N = None" />
    <P N="JackingStiffOrient" V="N" T="Text" D="Side of Web stiffened, L= Left, R = Right, B = Both, N = None" />
  </O>
</O>
<O N="G1FS4" T="SteelGirderMB" AlignH="Warp" AlignV="Warp" AlignT="None" X="76704" Y="117" Z="-12.5">
  <P N="StartStation" V="G1FS4.X" />
  <P N="Offset" V="G1FS4.Y" />
  <P N="Length" V="1056" />
  <P N="dw" V="66" D="Web depth of the I girder" />
  <P N="tw" V="0.6875" D="Web thickness of the I girder" />
  <P N="bft" V="20" D="Width of the top flange of the I girder" />
  <P N="tft" V="[0,342], 1.125,[342,702], 2.25,[702,1056], 1.125]" D="Thickness of the top flange of the I girder" />
  <P N="bfb" V="20" D="Width of the bottom flange of the I girder" />
  <P N="tfb" V="[0,342], 1.5,[342,702], 2.75,[702,1056], 1.5]" D="Thickness of the bottom flange of the I girder" />

```



```

<O N="StiffenerData" T="Group">
  <P N="WebStiffOrient" V="L" T="Text" D="Side of Web stiffened, L= Left, R = Right, B = Both" />
  <P N="WebStiffLoc" V="[36, 96, 216, 276, 396, 456, 576, 636, 756, 816, 936, 996]" D="Stiffener locations" />
  <P N="WebStiffT" V="0.625" D="Shear Stiffener Plate Thickness" />
  <P N="WebStiffW" V="6" D="Shear Stiffener Plate Width" />
  <P N="WebStiffHeight" V="dw" D="Shear Stiffener Height" />
  <P N="WebStiffClipH" V="1.5" D="Shear Stiffener Horizontal Clip" />
  <P N="WebStiffClipV" V="2.5" D="Shear Stiffener Vertical Clip" />
  <P N="ConnStiffOrient" V="L" T="Text" D="Side of Web stiffened, L= Left, R = Right, B = Both" />
  <P N="ConnStiffLoc" V="[156, 336, 696, 876]" D="Connector Stiffener locations" />
  <P N="ConnStiffT" V="0.75" D="Connection Stiffener Thickness" />
  <P N="ConnStiffW" V="8" D="Connector Plate Width" />
  <P N="ConnStiffHeight" V="dw" D="Connection Stiffener Height" />
  <P N="ConnStiffClipH" V="1.5" D="Connection Stiffener Horizontal Clip" />
  <P N="ConnStiffClipV" V="2.5" D="Connection Stiffener Vertical Clip" />
  <P N="BearingStiffOrient" V="B" T="Text" D="Side of Web stiffened, L= Left, R = Right, B = Both, N = None" />
  <P N="BearingStiffLoc" V="[516]" D="Bearing Stiffener locations" />
  <P N="BearingStiffT" V="1" D="Bearing Stiffener Thickness" />
  <P N="BearingStiffW" V="9" D="Bearing Plate Width" />
  <P N="BearingStiffHeight" V="dw" D="Bearing Stiffener Height" />
  <P N="BearingStiffClipH" V="1.5" D="Bearing Stiffener Horizontal Clip" />
  <P N="BearingStiffClipV" V="2.5" D="Bearing Stiffener Vertical Clip" />
  <P N="JackingStiffOrient" V="B" T="Text" D="Side of Web stiffened, L= Left, R = Right, B = Both, N = None" />
  <P N="JackingStiffLoc" V="[492,540]" D="Jacking Stiffener locations" />
  <P N="JackingStiffT" V="1" D="Jacking Stiffener Thickness" />
  <P N="JackingStiffW" V="9" D="Jacking Plate Width" />
  <P N="JackingStiffHeight" V="dw" D="Jacking Stiffener Height" />
  <P N="JackingStiffClipH" V="1.5" D="Jacking Stiffener Horizontal Clip" />
  <P N="JackingStiffClipV" V="2.5" D="Jacking Stiffener Vertical Clip" />
</O>
</O>
<O N="G1FS5" T="SteelGirderMB" AlignH="Warp" AlignV="Warp" AlignT="None" X="77760" Y="117" Z="-12.5">
  <P N="StartStation" V="G1FS5.X" />
  <P N="Offset" V="G1FS5.Y" />
  <P N="Length" V="1033" />
  <P N="dw" V="66" D="Web depth of the I girder" />
  <P N="tw" V="0.5" D="Web thickness of the I girder" />
  <P N="bft" V="16" D="Width of the top flange of the I girder" />
  <P N="tft" V="0.875" D="Thickness of the top flange of the I girder" />
  <P N="bfb" V="20" D="Width of the bottom flange of the I girder" />
  <P N="tfb" V="1.375" D="Thickness of the bottom flange of the I girder" />
  <O N="StiffenerData" T="Group">
    <P N="WebStiffOrient" V="L" T="Text" D="Side of Web stiffened, L= Left, R = Right, B = Both" />
    <P N="WebStiffLoc" V="[0, 60, 180, 240, 300, 360, 480, 540, 600, 660, 780, 840, 900, 960]" D="Stiffener locations"
  />
    <P N="WebStiffT" V="0.625" D="Shear Stiffener Plate Thickness" />
    <P N="WebStiffW" V="6" D="Shear Stiffener Plate Width" />
    <P N="WebStiffHeight" V="dw" D="Shear Stiffener Height" />
    <P N="WebStiffClipH" V="1.5" D="Shear Stiffener Horizontal Clip" />
    <P N="WebStiffClipV" V="2.5" D="Shear Stiffener Vertical Clip" />
    <P N="ConnStiffOrient" V="L" T="Text" D="Side of Web stiffened, L= Left, R = Right, B = Both" />
    <P N="ConnStiffLoc" V="[120, 420, 720]" D="Connector Stiffener locations" />
    <P N="ConnStiffT" V="0.75" D="Connection Stiffener Thickness" />
    <P N="ConnStiffW" V="8" D="Connector Plate Width" />
    <P N="ConnStiffHeight" V="dw" D="Connection Stiffener Height" />
    <P N="ConnStiffClipH" V="1.5" D="Connection Stiffener Horizontal Clip" />
    <P N="ConnStiffClipV" V="2.5" D="Connection Stiffener Vertical Clip" />
  </O>
  </O>

```

```

    <P N="BearingStiffOrient" V="B" T="Text" D="Side of Web stiffened, L = Left, R = Right, B = Both, N = None" />
    <P N="BearingStiffLoc" V="[1020]" D="Bearing Stiffener locations" />
    <P N="BearingStiffT" V="0.75" D="Bearing Stiffener Thickness" />
    <P N="BearingStiffW" V="7.5" D="Bearing Plate Width" />
    <P N="BearingStiffHeight" V="dw" D="Bearing Stiffener Height" />
    <P N="BearingStiffClipH" V="1.5" D="Bearing Stiffener Horizontal Clip" />
    <P N="BearingStiffClipV" V="2.5" D="Bearing Stiffener Vertical Clip" />
    <P N="JackingStiffOrient" V="N" T="Text" D="Side of Web stiffened, L = Left, R = Right, B = Both, N = None" />
  </O>
</O>
<O N="G1 Splices" T="Group" Z="-12.5" Y="117">
  <O N="SG1G2" T="BoltedFieldSplice (BB)" X="G1FS1.StartStation" AlignV="Warp" AlignH="Orient" AlignT="None">
    <P N="gap" V="1/4" />
    <P N="sp_sta" V="G1FS1.Length" />
    <P N="dwA" V="G1FS1.dw" D="Web depth of the I girder" />
    <P N="twA" V="G1FS1.tw" D="Web thickness of the I girder" />
    <P N="bftA" V="G1FS1.bft" D="Width of the top flange of the I girder" />
    <P N="tftA" V="G1FS1.tft" D="Thickness of the top flange of the I girder" />
    <P N="bfbA" V="G1FS1.bfb" D="Width of the bottom flange of the I girder" />
    <P N="tfbA" V="G1FS1.tfb" D="Thickness of the bottom flange of the I girder" />
    <P N="dwB" V="G1FS2.dw" D="Web depth of the I girder" />
    <P N="twB" V="G1FS2.tw" D="Web thickness of the I girder" />
    <P N="bftB" V="G1FS2.bft" D="Width of the top flange of the I girder" />
    <P N="tftB" V="G1FS2.tft" D="Thickness of the top flange of the I girder" />
    <P N="bfbB" V="G1FS2.bfb" D="Width of the bottom flange of the I girder" />
    <P N="tfbB" V="G1FS2.tfb" D="Thickness of the bottom flange of the I girder" />
  </O>
  <O N="SG2G3" T="BoltedFieldSplice (BB)" X="G1FS2.StartStation" AlignV="Warp" AlignH="Orient" AlignT="None">
    <P N="gap" V="1/4" />
    <P N="sp_sta" V="G1FS2.Length" />
    <P N="dwA" V="G1FS2.dw" D="Web depth of the I girder" />
    <P N="twA" V="G1FS2.tw" D="Web thickness of the I girder" />
    <P N="bftA" V="G1FS2.bft" D="Width of the top flange of the I girder" />
    <P N="tftA" V="G1FS2.tft" D="Thickness of the top flange of the I girder" />
    <P N="bfbA" V="G1FS2.bfb" D="Width of the bottom flange of the I girder" />
    <P N="tfbA" V="G1FS2.tfb" D="Thickness of the bottom flange of the I girder" />
    <P N="dwB" V="G1FS3.dw" D="Web depth of the I girder" />
    <P N="twB" V="G1FS3.tw" D="Web thickness of the I girder" />
    <P N="bftB" V="G1FS3.bft" D="Width of the top flange of the I girder" />
    <P N="tftB" V="G1FS3.tft" D="Thickness of the top flange of the I girder" />
    <P N="bfbB" V="G1FS3.bfb" D="Width of the bottom flange of the I girder" />
    <P N="tfbB" V="G1FS3.tfb" D="Thickness of the bottom flange of the I girder" />
  </O>
  <O N="SG3G4" T="BoltedFieldSplice (BB)" X="G1FS3.StartStation" AlignV="Warp" AlignH="Orient" AlignT="None">
    <P N="gap" V="1/4" />
    <P N="sp_sta" V="G1FS3.Length" />
    <P N="dwA" V="G1FS3.dw" D="Web depth of the I girder" />
    <P N="twA" V="G1FS3.tw" D="Web thickness of the I girder" />
    <P N="bftA" V="G1FS3.bft" D="Width of the top flange of the I girder" />
    <P N="tftA" V="G1FS3.tft" D="Thickness of the top flange of the I girder" />
    <P N="bfbA" V="G1FS3.bfb" D="Width of the bottom flange of the I girder" />
    <P N="tfbA" V="G1FS3.tfb" D="Thickness of the bottom flange of the I girder" />
    <P N="dwB" V="G1FS4.dw" D="Web depth of the I girder" />
    <P N="twB" V="G1FS4.tw" D="Web thickness of the I girder" />
    <P N="bftB" V="G1FS4.bft" D="Width of the top flange of the I girder" />
    <P N="tftB" V="G1FS4.tft" D="Thickness of the top flange of the I girder" />
    <P N="bfbB" V="G1FS4.bfb" D="Width of the bottom flange of the I girder" />
  </O>

```

```

    <P N="tfbB" V="G1FS4.tfb" D="Thickness of the bottom flange of the I girder" />
  </O>
<O N="SG4G5" T="BoltedFieldSplice (BB)" X="G1FS4.StartStation" AlignV="Warp" AlignH="Orient" AlignT="None">
  <P N="gap" V="1/4" />
  <P N="sp_sta" V="G1FS4.Length" />
  <P N="dwA" V="G1FS4.dw" D="Web depth of the I girder" />
  <P N="twA" V="G1FS4.tw" D="Web thickness of the I girder" />
  <P N="bftA" V="G1FS4.bft" D="Width of the top flange of the I girder" />
  <P N="tftA" V="G1FS4.tft" D="Thickness of the top flange of the I girder" />
  <P N="bfbA" V="G1FS4.bfb" D="Width of the bottom flange of the I girder" />
  <P N="tfbA" V="G1FS4.tfb" D="Thickness of the bottom flange of the I girder" />
  <P N="dwB" V="G1FS5.dw" D="Web depth of the I girder" />
  <P N="twB" V="G1FS5.tw" D="Web thickness of the I girder" />
  <P N="bftB" V="G1FS5.bft" D="Width of the top flange of the I girder" />
  <P N="tftB" V="G1FS5.tft" D="Thickness of the top flange of the I girder" />
  <P N="bfbB" V="G1FS5.bfb" D="Width of the bottom flange of the I girder" />
  <P N="tfbB" V="G1FS5.tfb" D="Thickness of the bottom flange of the I girder" />
</O>
</O>
</O>
<O N="Girder 2" T="Group">
  <O N="G2FS1" T="SteelGirderMB" Z="-12.5" Y="3" X="73487" AlignV="Warp" AlignH="Warp" AlignT="None">
    <P N="StartStation" V="G2FS1.X" />
    <P N="Offset" V="G2FS1.Y" />
    <P N="Length" V="1033" />
    <P N="dw" V="66" D="Web depth of the I girder" />
    <P N="tw" V="0.6875" D="Web thickness of the I girder" />
    <P N="bft" V="16" D="Width of the top flange of the I girder" />
    <P N="tft" V="0.875" D="Thickness of the top flange of the I girder" />
    <P N="bfb" V="16" D="Width of the bottom flange of the I girder" />
    <P N="tfb" V="1" D="Thickness of the bottom flange of the I girder" />
  <O N="StiffenerData" T="Group">
    <P N="WebStiffOrient" V="N" T="Text" D="Side of Web stiffened, L = Left, R = Right, B = Both" />
    <P N="ConnStiffOrient" V="B" T="Text" D="Side of Web stiffened, L = Left, R = Right, B = Both" />
    <P N="ConnStiffLoc" V="[253, 493, 733, 973]" D="Connector Stiffener Locations" />
    <P N="ConnStiffT" V="0.75" D="Connector Stiffener Thickness" />
    <P N="ConnStiffW" V="8" D="Connector Plate Width" />
    <P N="ConnStiffHeight" V="dw" D="Jacking Stiffener Height" />
    <P N="ConnStiffClipH" V="1.5" D="Jacking Stiffener Horizontal Clip" />
    <P N="ConnStiffClipV" V="2.5" D="Jacking Stiffener Vertical Clip" />
    <P N="BearingStiffOrient" V="B" T="Text" D="Side of Web stiffened, L = Left, R = Right, B = Both, N = None" />
    <P N="BearingStiffLoc" V="[13]" D="Bearing Stiffener Locations" />
    <P N="BearingStiffT" V="0.75" D="Bearing Stiffener Thickness" />
    <P N="BearingStiffW" V="7.5" D="Bearing Plate Width" />
    <P N="BearingStiffHeight" V="dw" D="Jacking Stiffener Height" />
    <P N="BearingStiffClipH" V="1.5" D="Jacking Stiffener Horizontal Clip" />
    <P N="BearingStiffClipV" V="2.5" D="Jacking Stiffener Vertical Clip" />
    <P N="JackingStiffOrient" V="N" T="Text" D="Side of Web stiffened, L = Left, R = Right, B = Both, N = None" />
  </O>
</O>
</O>
<O N="G2FS2" T="SteelGirderMB" AlignH="Warp" AlignV="Warp" AlignT="None" X="74520" Y="3" Z="-12.5">
  <P N="StartStation" V="G2FS2.X" />
  <P N="Offset" V="G2FS2.Y" />
  <P N="Length" V="1056" />
  <P N="dw" V="66" D="Web depth of the I girder" />
  <P N="tw" V="0.6875" D="Web thickness of the I girder" />
  <P N="bft" V="20" D="Width of the top flange of the I girder" />

```

```

<P N="tft" V="[0,348], 1.125,[348,711], 2.25,[711,1056], 1.125]" D="Thickness of the top flange of the I girder" />
<P N="bfb" V="20" D="Width of the bottom flange of the I girder" />
<P N="tfb" V="[0,348], 1.5,[348,711], 2.75,[711,1056], 1.5]" D="Thickness of the bottom flange of the I girder" />
<O N="Stiffener Data" T="Group">
  <P N="WebStiffOrient" V="N" T="Text" D="Side of Web stiffened, L= Left, R = Right, B = Both" />
  <P N="ConnStiffOrient" V="B" T="Text" D="Side of Web stiffened, L= Left, R = Right, B = Both" />
  <P N="ConnStiffLoc" V="[180, 360, 720, 900]" D="Connector Stiffener locations" />
  <P N="ConnStiffT" V="0.75" D="Connector Stiffener Thickness" />
  <P N="ConnStiffW" V="8" D="Connector Plate Width" />
  <P N="ConnStiffHeight" V="dw" D="Jacking Stiffener Height" />
  <P N="ConnStiffClipH" V="1.5" D="Jacking Stiffener Horizontal Clip" />
  <P N="ConnStiffClipV" V="2.5" D="Jacking Stiffener Vertical Clip" />
  <P N="BearingStiffOrient" V="B" T="Text" D="Side of Web stiffened, L= Left, R = Right, B = Both, N = None" />
  <P N="BearingStiffLoc" V="[540]" D="Bearing Stiffener locations" />
  <P N="BearingStiffT" V="1" D="Bearing Stiffener Thickness" />
  <P N="BearingStiffW" V="9" D="Bearing Plate Width" />
  <P N="BearingStiffHeight" V="dw" D="Jacking Stiffener Height" />
  <P N="BearingStiffClipH" V="1.5" D="Jacking Stiffener Horizontal Clip" />
  <P N="BearingStiffClipV" V="2.5" D="Jacking Stiffener Vertical Clip" />
  <P N="JackingStiffOrient" V="B" T="Text" D="Side of Web stiffened, L= Left, R = Right, B = Both, N = None" />
  <P N="JackingStiffLoc" V="[516,564]" D="Jacking Stiffener locations" />
  <P N="JackingStiffT" V="1" D="Jacking Stiffener Thickness" />
  <P N="JackingStiffW" V="9" D="Jacking Plate Width" />
  <P N="JackingStiffHeight" V="dw" D="Jacking Stiffener Height" />
  <P N="JackingStiffClipH" V="1.5" D="Jacking Stiffener Horizontal Clip" />
  <P N="JackingStiffClipV" V="2.5" D="Jacking Stiffener Vertical Clip" />
</O>
</O>
<O N="G2FS3" T="SteelGirderMB" AlignH="Warp" AlignV="Warp" AlignT="None" X="75576" Y="3" Z="-12.5">
  <P N="StartStation" V="G2FS3.X" />
  <P N="Offset" V="G2FS3.Y" />
  <P N="Length" V="1128" />
  <P N="dw" V="66" D="Web depth of the I girder" />
  <P N="tw" V="0.6875" D="Web thickness of the I girder" />
  <P N="bft" V="16" D="Width of the top flange of the I girder" />
  <P N="tft" V="0.875" D="Thickness of the top flange of the I girder" />
  <P N="bfb" V="16" D="Width of the bottom flange of the I girder" />
  <P N="tfb" V="1.375" D="Thickness of the bottom flange of the I girder" />
  <O N="Stiffener Data" T="Group">
    <P N="WebStiffOrient" V="N" T="Text" D="Side of Web stiffened, L= Left, R = Right, B = Both" />
    <P N="ConnStiffOrient" V="B" T="Text" D="Side of Web stiffened, L= Left, R = Right, B = Both" />
    <P N="ConnStiffLoc" V="[84, 324, 564, 804, 1044]" D="Connector Stiffener locations" />
    <P N="ConnStiffT" V="0.75" D="Connector Stiffener Thickness" />
    <P N="ConnStiffW" V="8" D="Connector Plate Width" />
    <P N="ConnStiffHeight" V="dw" D="Jacking Stiffener Height" />
    <P N="ConnStiffClipH" V="1.5" D="Jacking Stiffener Horizontal Clip" />
    <P N="ConnStiffClipV" V="2.5" D="Jacking Stiffener Vertical Clip" />
    <P N="BearingStiffOrient" V="N" T="Text" D="Side of Web stiffened, L= Left, R = Right, B = Both, N = None" />
    <P N="JackingStiffOrient" V="N" T="Text" D="Side of Web stiffened, L= Left, R = Right, B = Both, N = None" />
  </O>
</O>
<O N="G2FS4" T="SteelGirderMB" AlignH="Warp" AlignV="Warp" AlignT="None" X="76704" Y="3" Z="-12.5">
  <P N="StartStation" V="G2FS4.X" />
  <P N="Offset" V="G2FS4.Y" />
  <P N="Length" V="1056" />
  <P N="dw" V="66" D="Web depth of the I girder" />
  <P N="tw" V="0.6875" D="Web thickness of the I girder" />

```

```

<P N="bft" V="20" D="Width of the top flange of the I girder" />
<P N="tft" V="[0,342], 1.25,[342,702], 2.25,[702,1056], 1.25]" D="Thickness of the top flange of the I girder" />
<P N="bfb" V="20" D="Width of the bottom flange of the I girder" />
<P N="tfb" V="[0,342], 1.25,[342,702], 2.5,[702,1056], 1.25]" D="Thickness of the bottom flange of the I girder" />
<O N="Stiffener Data" T="Group">
  <P N="WebStiffOrient" V="N" T="Text" D="Side of Web stiffened, L= Left, R = Right, B = Both" />
  <P N="ConnStiffOrient" V="B" T="Text" D="Side of Web stiffened, L= Left, R = Right, B = Both" />
  <P N="ConnStiffLoc" V="[156, 336, 696, 876]" D="Connector Stiffener Locations" />
  <P N="ConnStiffT" V="0.75" D="Connector Stiffener Thickness" />
  <P N="ConnStiffW" V="8" D="Connector Plate Width" />
  <P N="ConnStiffHeight" V="dw" D="Jacking Stiffener Height" />
  <P N="ConnStiffClipH" V="1.5" D="Jacking Stiffener Horizontal Clip" />
  <P N="ConnStiffClipV" V="2.5" D="Jacking Stiffener Vertical Clip" />
  <P N="BearingStiffOrient" V="B" T="Text" D="Side of Web stiffened, L= Left, R = Right, B = Both, N = None" />
  <P N="BearingStiffLoc" V="[516]" D="Bearing Stiffener locations" />
  <P N="BearingStiffT" V="1" D="Bearing Stiffener Thickness" />
  <P N="BearingStiffW" V="9" D="Bearing Plate Width" />
  <P N="BearingStiffHeight" V="dw" D="Jacking Stiffener Height" />
  <P N="BearingStiffClipH" V="1.5" D="Jacking Stiffener Horizontal Clip" />
  <P N="BearingStiffClipV" V="2.5" D="Jacking Stiffener Vertical Clip" />
  <P N="JackingStiffOrient" V="B" T="Text" D="Side of Web stiffened, L= Left, R = Right, B = Both, N = None" />
  <P N="JackingStiffLoc" V="[492,540]" D="Jacking Stiffener Locations" />
  <P N="JackingStiffT" V="1" D="Jacking Stiffener Thickness" />
  <P N="JackingStiffW" V="9" D="Jacking Plate Width" />
  <P N="JackingStiffHeight" V="dw" D="Jacking Stiffener Height" />
  <P N="JackingStiffClipH" V="1.5" D="Jacking Stiffener Horizontal Clip" />
  <P N="JackingStiffClipV" V="2.5" D="Jacking Stiffener Vertical Clip" />
</O>
</O>
<O N="G2FS5" T="SteelGirderMB" AlignH="Warp" AlignV="Warp" AlignT="None" X="77760" Y="3" Z="-12.5">
  <P N="StartStation" V="G2FS5.X" />
  <P N="Offset" V="G2FS5.Y" />
  <P N="Length" V="1033" />
  <P N="dw" V="66" D="Web depth of the I girder" />
  <P N="tw" V="0.5" D="Web thickness of the I girder" />
  <P N="bft" V="16" D="Width of the top flange of the I girder" />
  <P N="tft" V="0.875" D="Thickness of the top flange of the I girder" />
  <P N="bfb" V="16" D="Width of the bottom flange of the I girder" />
  <P N="tfb" V="1" D="Thickness of the bottom flange of the I girder" />
  <O N="Stiffener Data" T="Group">
    <P N="WebStiffOrient" V="N" T="Text" D="Side of Web stiffened, L= Left, R = Right, B = Both" />
    <P N="ConnStiffOrient" V="B" T="Text" D="Side of Web stiffened, L= Left, R = Right, B = Both" />
    <P N="ConnStiffLoc" V="[120, 420, 720]" D="Connector Stiffener Locations" />
    <P N="ConnStiffT" V="0.75" D="Connector Stiffener Thickness" />
    <P N="ConnStiffW" V="8" D="Connector Plate Width" />
    <P N="ConnStiffHeight" V="dw" D="Jacking Stiffener Height" />
    <P N="ConnStiffClipH" V="1.5" D="Jacking Stiffener Horizontal Clip" />
    <P N="ConnStiffClipV" V="2.5" D="Jacking Stiffener Vertical Clip" />
    <P N="BearingStiffOrient" V="B" T="Text" D="Side of Web stiffened, L= Left, R = Right, B = Both, N = None" />
    <P N="BearingStiffLoc" V="[1020]" D="Bearing Stiffener locations" />
    <P N="BearingStiffT" V="0.75" D="Bearing Stiffener Thickness" />
    <P N="BearingStiffW" V="7.5" D="Bearing Plate Width" />
    <P N="BearingStiffHeight" V="dw" D="Bearing Stiffener Height" />
    <P N="BearingStiffClipH" V="1.5" D="Bearing Stiffener Horizontal Clip" />
    <P N="BearingStiffClipV" V="2.5" D="Bearing Stiffener Vertical Clip" />
    <P N="JackingStiffOrient" V="N" T="Text" D="Side of Web stiffened, L= Left, R = Right, B = Both, N = None" />
  </O>
</O>

```

```

</O>
<O N="G2 Splices" T="Group" Z="-12.5" Y="3">
  <O N="SG1G2" T="BoltedFieldSplice (BB)" X="G2FS1.StartStation" AlignV="Warp" AlignH="Orient" AlignT="None">
    <P N="gap" V="1/4" />
    <P N="sp_sta" V="G2FS1.Length" />
    <P N="dwA" V="G2FS1.dw" D="Web depth of the I girder" />
    <P N="twA" V="G2FS1.tw" D="Web thickness of the I girder" />
    <P N="bftA" V="G2FS1.bft" D="Width of the top flange of the I girder" />
    <P N="tftA" V="G2FS1.tft" D="Thickness of the top flange of the I girder" />
    <P N="bfbA" V="G2FS1.bfb" D="Width of the bottom flange of the I girder" />
    <P N="tfbA" V="G2FS1.tfb" D="Thickness of the bottom flange of the I girder" />
    <P N="dwB" V="G2FS2.dw" D="Web depth of the I girder" />
    <P N="twB" V="G2FS2.tw" D="Web thickness of the I girder" />
    <P N="bftB" V="G2FS2.bft" D="Width of the top flange of the I girder" />
    <P N="tftB" V="G2FS2.tft" D="Thickness of the top flange of the I girder" />
    <P N="bfbB" V="G2FS2.bfb" D="Width of the bottom flange of the I girder" />
    <P N="tfbB" V="G2FS2.tfb" D="Thickness of the bottom flange of the I girder" />
  </O>
  <O N="SG2G3" T="BoltedFieldSplice (BB)" X="G2FS2.StartStation" AlignV="Warp" AlignH="Orient" AlignT="None">
    <P N="gap" V="1/4" />
    <P N="sp_sta" V="G2FS2.Length" />
    <P N="dwA" V="G2FS2.dw" D="Web depth of the I girder" />
    <P N="twA" V="G2FS2.tw" D="Web thickness of the I girder" />
    <P N="bftA" V="G2FS2.bft" D="Width of the top flange of the I girder" />
    <P N="tftA" V="G2FS2.tft" D="Thickness of the top flange of the I girder" />
    <P N="bfbA" V="G2FS2.bfb" D="Width of the bottom flange of the I girder" />
    <P N="tfbA" V="G2FS2.tfb" D="Thickness of the bottom flange of the I girder" />
    <P N="dwB" V="G2FS3.dw" D="Web depth of the I girder" />
    <P N="twB" V="G2FS3.tw" D="Web thickness of the I girder" />
    <P N="bftB" V="G2FS3.bft" D="Width of the top flange of the I girder" />
    <P N="tftB" V="G2FS3.tft" D="Thickness of the top flange of the I girder" />
    <P N="bfbB" V="G2FS3.bfb" D="Width of the bottom flange of the I girder" />
    <P N="tfbB" V="G2FS3.tfb" D="Thickness of the bottom flange of the I girder" />
  </O>
  <O N="SG3G4" T="BoltedFieldSplice (BB)" X="G2FS3.StartStation" AlignV="Warp" AlignH="Orient" AlignT="None">
    <P N="gap" V="1/4" />
    <P N="sp_sta" V="G2FS3.Length" />
    <P N="dwA" V="G2FS3.dw" D="Web depth of the I girder" />
    <P N="twA" V="G2FS3.tw" D="Web thickness of the I girder" />
    <P N="bftA" V="G2FS3.bft" D="Width of the top flange of the I girder" />
    <P N="tftA" V="G2FS3.tft" D="Thickness of the top flange of the I girder" />
    <P N="bfbA" V="G2FS3.bfb" D="Width of the bottom flange of the I girder" />
    <P N="tfbA" V="G2FS3.tfb" D="Thickness of the bottom flange of the I girder" />
    <P N="dwB" V="G2FS4.dw" D="Web depth of the I girder" />
    <P N="twB" V="G2FS4.tw" D="Web thickness of the I girder" />
    <P N="bftB" V="G2FS4.bft" D="Width of the top flange of the I girder" />
    <P N="tftB" V="G2FS4.tft" D="Thickness of the top flange of the I girder" />
    <P N="bfbB" V="G2FS4.bfb" D="Width of the bottom flange of the I girder" />
    <P N="tfbB" V="G2FS4.tfb" D="Thickness of the bottom flange of the I girder" />
  </O>
  <O N="SG4G5" T="BoltedFieldSplice (BB)" X="G2FS4.StartStation" AlignV="Warp" AlignH="Orient" AlignT="None">
    <P N="gap" V="1/4" />
    <P N="sp_sta" V="G2FS4.Length" />
    <P N="dwA" V="G2FS4.dw" D="Web depth of the I girder" />
    <P N="twA" V="G2FS4.tw" D="Web thickness of the I girder" />
    <P N="bftA" V="G2FS4.bft" D="Width of the top flange of the I girder" />
    <P N="tftA" V="G2FS4.tft" D="Thickness of the top flange of the I girder" />
  </O>

```

```

<P N="bfbA" V="G2FS4.bfb" D="Width of the bottom flange of the I girder" />
<P N="tfbA" V="G2FS4.tfb" D="Thickness of the bottom flange of the I girder" />
<P N="dwB" V="G2FS5.dw" D="Web depth of the I girder" />
<P N="twB" V="G2FS5.tw" D="Web thickness of the I girder" />
<P N="bftB" V="G2FS5.bft" D="Width of the top flange of the I girder" />
<P N="tftB" V="G2FS5.tft" D="Thickness of the top flange of the I girder" />
<P N="bfbB" V="G2FS5.bfb" D="Width of the bottom flange of the I girder" />
<P N="tfbB" V="G2FS5.tfb" D="Thickness of the bottom flange of the I girder" />
</O>
</O>
<O N="Girder 3" T="Group">
  <O N="G3FS1" T="SteelGirderMB" Z="-12.5" Y="-111" X="73487" AlignV="Warp" AlignH="Warp" AlignT="None">
    <P N="StartStation" V="G3FS1.X" />
    <P N="Offset" V="G3FS1.Y" />
    <P N="Length" V="1033" />
    <P N="dw" V="66" D="Web depth of the I girder" />
    <P N="tw" V="0.6875" D="Web thickness of the I girder" />
    <P N="bft" V="16" D="Width of the top flange of the I girder" />
    <P N="tft" V="0.875" D="Thickness of the top flange of the I girder" />
    <P N="bfb" V="16" D="Width of the bottom flange of the I girder" />
    <P N="tfb" V="1" D="Thickness of the bottom flange of the I girder" />
    <O N="Stiffener Data" T="Group">
      <P N="WebStiffOrient" V="N" T="Text" D="Side of Web stiffened, L= Left, R = Right, B = Both" />
      <P N="ConnStiffOrient" V="B" T="Text" D="Side of Web stiffened, L= Left, R = Right, B = Both" />
      <P N="ConnStiffLoc" V="[253, 493, 733, 973]" D="Connector Stiffener locations" />
      <P N="ConnStiffT" V="0.75" D="Connector Stiffener Thickness" />
      <P N="ConnStiffW" V="8" D="Connector Plate Width" />
      <P N="ConnStiffHeight" V="dw" D="Jacking Stiffener Height" />
      <P N="ConnStiffClipH" V="1.5" D="Jacking Stiffener Horizontal Clip" />
      <P N="ConnStiffClipV" V="2.5" D="Jacking Stiffener Vertical Clip" />
      <P N="BearingStiffOrient" V="B" T="Text" D="Side of Web stiffened, L= Left, R = Right, B = Both, N = None" />
      <P N="BearingStiffLoc" V="[13]" D="Bearing Stiffener locations" />
      <P N="BearingStiffT" V="0.75" D="Bearing Stiffener Thickness" />
      <P N="BearingStiffW" V="7.5" D="Bearing Plate Width" />
      <P N="BearingStiffHeight" V="dw" D="Jacking Stiffener Height" />
      <P N="BearingStiffClipH" V="1.5" D="Jacking Stiffener Horizontal Clip" />
      <P N="BearingStiffClipV" V="2.5" D="Jacking Stiffener Vertical Clip" />
      <P N="JackingStiffOrient" V="N" T="Text" D="Side of Web stiffened, L= Left, R = Right, B = Both, N = None" />
    </O>
  </O>
  <O N="G3FS2" T="SteelGirderMB" AlignH="Warp" AlignV="Warp" AlignT="None" X="74520" Y="-111" Z="-12.5">
    <P N="StartStation" V="G3FS2.X" />
    <P N="Offset" V="G3FS2.Y" />
    <P N="Length" V="1056" />
    <P N="dw" V="66" D="Web depth of the I girder" />
    <P N="tw" V="0.6875" D="Web thickness of the I girder" />
    <P N="bft" V="20" D="Width of the top flange of the I girder" />
    <P N="tft" V="[0,348], 1.125,[348,711], 2.25,[711,1056], 1.125]" D="Thickness of the top flange of the I girder" />
    <P N="bfb" V="20" D="Width of the bottom flange of the I girder" />
    <P N="tfb" V="[0,348], 1.5,[348,711], 2.75,[711,1056], 1.5]" D="Thickness of the bottom flange of the I girder" />
    <O N="Stiffener Data" T="Group">
      <P N="WebStiffOrient" V="N" T="Text" D="Side of Web stiffened, L= Left, R = Right, B = Both" />
      <P N="ConnStiffOrient" V="B" T="Text" D="Side of Web stiffened, L= Left, R = Right, B = Both" />
      <P N="ConnStiffLoc" V="[180, 360, 720, 900]" D="Connector Stiffener locations" />
      <P N="ConnStiffT" V="0.75" D="Connector Stiffener Thickness" />
      <P N="ConnStiffW" V="8" D="Connector Plate Width" />
    </O>
  </O>

```

```

<P N="ConnStiffHeight" V="dw" D="Jacking Stiffener Height" />
<P N="ConnStiffClipH" V="1.5" D="Jacking Stiffener Horizontal Clip" />
<P N="ConnStiffClipV" V="2.5" D="Jacking Stiffener Vertical Clip" />
<P N="BearingStiffOrient" V="B" T="Text" D="Side of Web stiffened, L= Left, R = Right, B = Both, N = None" />
<P N="BearingStiffLoc" V="[540]" D="Bearing Stiffener locations" />
<P N="BearingStiffT" V="1" D="Bearing Stiffener Thickness" />
<P N="BearingStiffW" V="9" D="Bearing Plate Width" />
<P N="BearingStiffHeight" V="dw" D="Jacking Stiffener Height" />
<P N="BearingStiffClipH" V="1.5" D="Jacking Stiffener Horizontal Clip" />
<P N="BearingStiffClipV" V="2.5" D="Jacking Stiffener Vertical Clip" />
<P N="JackingStiffOrient" V="B" T="Text" D="Side of Web stiffened, L= Left, R = Right, B = Both, N = None" />
<P N="JackingStiffLoc" V="[516,564]" D="Jacking Stiffener locations" />
<P N="JackingStiffT" V="1" D="Jacking Stiffener Thickness" />
<P N="JackingStiffW" V="9" D="Jacking Plate Width" />
<P N="JackingStiffHeight" V="dw" D="Jacking Stiffener Height" />
<P N="JackingStiffClipH" V="1.5" D="Jacking Stiffener Horizontal Clip" />
<P N="JackingStiffClipV" V="2.5" D="Jacking Stiffener Vertical Clip" />
</O>
</O>
<O N="G3FS3" T="SteelGirderMB" AlignH="Warp" AlignV="Warp" AlignT="None" X="75576" Y="-111" Z="-12.5">
  <P N="StartStation" V="G3FS3.X" />
  <P N="Offset" V="G3FS3.Y" />
  <P N="Length" V="1128" />
  <P N="dw" V="66" D="Web depth of the I girder" />
  <P N="tw" V="0.6875" D="Web thickness of the I girder" />
  <P N="bft" V="16" D="Width of the top flange of the I girder" />
  <P N="tft" V="0.875" D="Thickness of the top flange of the I girder" />
  <P N="bfb" V="16" D="Width of the bottom flange of the I girder" />
  <P N="tfb" V="1.375" D="Thickness of the bottom flange of the I girder" />
  <O N="Stiffener Data" T="Group">
    <P N="WebStiffOrient" V="N" T="Text" D="Side of Web stiffened, L= Left, R = Right, B = Both" />
    <P N="ConnStiffOrient" V="B" T="Text" D="Side of Web stiffened, L= Left, R = Right, B = Both" />
    <P N="ConnStiffLoc" V="[84, 324, 564, 804, 1044]" D="Connector Stiffener locations" />
    <P N="ConnStiffT" V="0.75" D="Connector Stiffener Thickness" />
    <P N="ConnStiffW" V="8" D="Connector Plate Width" />
    <P N="ConnStiffHeight" V="dw" D="Jacking Stiffener Height" />
    <P N="ConnStiffClipH" V="1.5" D="Jacking Stiffener Horizontal Clip" />
    <P N="ConnStiffClipV" V="2.5" D="Jacking Stiffener Vertical Clip" />
    <P N="BearingStiffOrient" V="N" T="Text" D="Side of Web stiffened, L= Left, R = Right, B = Both, N = None" />
    <P N="JackingStiffOrient" V="N" T="Text" D="Side of Web stiffened, L= Left, R = Right, B = Both, N = None" />
  </O>
</O>
<O N="G3FS4" T="SteelGirderMB" AlignH="Warp" AlignV="Warp" AlignT="None" X="76704" Y="-111" Z="-12.5">
  <P N="StartStation" V="G3FS4.X" />
  <P N="Offset" V="G3FS4.Y" />
  <P N="Length" V="1056" />
  <P N="dw" V="66" D="Web depth of the I girder" />
  <P N="tw" V="0.6875" D="Web thickness of the I girder" />
  <P N="bft" V="20" D="Width of the top flange of the I girder" />
  <P N="tft" V="[[0,342], 1.25,[342,702], 2.25,[702,1056], 1.25]" D="Thickness of the top flange of the I girder" />
  <P N="bfb" V="20" D="Width of the bottom flange of the I girder" />
  <P N="tfb" V="[[0,342], 1.25,[342,702], 2.5,[702,1056], 1.25]" D="Thickness of the bottom flange of the I girder" />
  <O N="Stiffener Data" T="Group">
    <P N="WebStiffOrient" V="N" T="Text" D="Side of Web stiffened, L= Left, R = Right, B = Both" />
    <P N="ConnStiffOrient" V="B" T="Text" D="Side of Web stiffened, L= Left, R = Right, B = Both" />
    <P N="ConnStiffLoc" V="[156, 336, 696, 876]" D="Connector Stiffener locations" />
    <P N="ConnStiffT" V="0.75" D="Connector Stiffener Thickness" />
  </O>

```



```

<P N="ConnStiffW" V="8" D="Connector Plate Width" />
<P N="ConnStiffHeight" V="dw" D="Jacking Stiffener Height" />
<P N="ConnStiffClipH" V="1.5" D="Jacking Stiffener Horizontal Clip" />
<P N="ConnStiffClipV" V="2.5" D="Jacking Stiffener Vertical Clip" />
<P N="BearingStiffOrient" V="B" T="Text" D="Side of Web stiffened, L= Left, R = Right, B = Both, N = None" />
<P N="BearingStiffLoc" V="[516]" D="Bearing Stiffener locations" />
<P N="BearingStiffT" V="1" D="Bearing Stiffener Thickness" />
<P N="BearingStiffW" V="9" D="Bearing Plate Width" />
<P N="BearingStiffHeight" V="dw" D="Jacking Stiffener Height" />
<P N="BearingStiffClipH" V="1.5" D="Jacking Stiffener Horizontal Clip" />
<P N="BearingStiffClipV" V="2.5" D="Jacking Stiffener Vertical Clip" />
<P N="JackingStiffOrient" V="B" T="Text" D="Side of Web stiffened, L= Left, R = Right, B = Both, N = None" />
<P N="JackingStiffLoc" V="[492,540]" D="Jacking Stiffener locations" />
<P N="JackingStiffT" V="1" D="Jacking Stiffener Thickness" />
<P N="JackingStiffW" V="9" D="Jacking Plate Width" />
<P N="JackingStiffHeight" V="dw" D="Jacking Stiffener Height" />
<P N="JackingStiffClipH" V="1.5" D="Jacking Stiffener Horizontal Clip" />
<P N="JackingStiffClipV" V="2.5" D="Jacking Stiffener Vertical Clip" />
</O>
</O>
<O N="G3FS5" T="SteelGirderMB" AlignH="Warp" AlignV="Warp" AlignT="None" X="77760" Y="-111" Z="-12.5">
  <P N="StartStation" V="G3FS5.X" />
  <P N="Offset" V="G3FS5.Y" />
  <P N="Length" V="1033" />
  <P N="dw" V="66" D="Web depth of the I girder" />
  <P N="tw" V="0.5" D="Web thickness of the I girder" />
  <P N="bft" V="16" D="Width of the top flange of the I girder" />
  <P N="tft" V="0.875" D="Thickness of the top flange of the I girder" />
  <P N="bfb" V="16" D="Width of the bottom flange of the I girder" />
  <P N="tfb" V="1" D="Thickness of the bottom flange of the I girder" />
  <O N="StiffenerData" T="Group">
    <P N="WebStiffOrient" V="N" T="Text" D="Side of Web stiffened, L= Left, R = Right, B = Both" />
    <P N="ConnStiffOrient" V="B" T="Text" D="Side of Web stiffened, L= Left, R = Right, B = Both" />
    <P N="ConnStiffLoc" V="[120, 420, 720]" D="Connector Stiffener locations" />
    <P N="ConnStiffT" V="0.75" D="Connector Stiffener Thickness" />
    <P N="ConnStiffW" V="8" D="Connector Plate Width" />
    <P N="ConnStiffHeight" V="dw" D="Jacking Stiffener Height" />
    <P N="ConnStiffClipH" V="1.5" D="Jacking Stiffener Horizontal Clip" />
    <P N="ConnStiffClipV" V="2.5" D="Jacking Stiffener Vertical Clip" />
    <P N="BearingStiffOrient" V="B" T="Text" D="Side of Web stiffened, L= Left, R = Right, B = Both, N = None" />
    <P N="BearingStiffLoc" V="[1020]" D="Bearing Stiffener locations" />
    <P N="BearingStiffT" V="0.75" D="Bearing Stiffener Thickness" />
    <P N="BearingStiffW" V="7.5" D="Bearing Plate Width" />
    <P N="BearingStiffHeight" V="dw" D="Bearing Stiffener Height" />
    <P N="BearingStiffClipH" V="1.5" D="Bearing Stiffener Horizontal Clip" />
    <P N="BearingStiffClipV" V="2.5" D="Bearing Stiffener Vertical Clip" />
    <P N="JackingStiffOrient" V="N" T="Text" D="Side of Web stiffened, L= Left, R = Right, B = Both, N = None" />
  </O>
</O>
</O>
<O N="G3 Splices" T="Group" Z="-12.5" Y="-111">
  <O N="SG1G2" T="BoltedFieldSplice (BB)" X="G3FS1.StartStation" AlignV="Warp" AlignH="Orient" AlignT="None">
    <P N="gap" V="1/4" />
    <P N="sp_sta" V="G3FS1.Length" />
    <P N="dwa" V="G3FS1.dw" D="Web depth of the I girder" />
    <P N="twa" V="G3FS1.tw" D="Web thickness of the I girder" />
    <P N="bftA" V="G3FS1.bft" D="Width of the top flange of the I girder" />
    <P N="tftA" V="G3FS1.tft" D="Thickness of the top flange of the I girder" />
  </O>
</O>

```

```

<P N="bfbA" V="G3FS1.bfb" D="Width of the bottom flange of the I girder" />
<P N="tfbA" V="G3FS1.tfb" D="Thickness of the bottom flange of the I girder" />
<P N="dwB" V="G3FS2.dw" D="Web depth of the I girder" />
<P N="twB" V="G3FS2.tw" D="Web thickness of the I girder" />
<P N="bftB" V="G3FS2.bft" D="Width of the top flange of the I girder" />
<P N="tftB" V="G3FS2.tft" D="Thickness of the top flange of the I girder" />
<P N="bfbB" V="G3FS2.bfb" D="Width of the bottom flange of the I girder" />
<P N="tfbB" V="G3FS2.tfb" D="Thickness of the bottom flange of the I girder" />
</O>
<O N="SG2G3" T="BoltedFieldSplice (BB)" X="G3FS2.StartStation" AlignV="Warp" AlignH="Orient" AlignT="None">
  <P N="gap" V="1/4" />
  <P N="sp_sta" V="G3FS2.Length" />
  <P N="dwA" V="G3FS2.dw" D="Web depth of the I girder" />
  <P N="twA" V="G3FS2.tw" D="Web thickness of the I girder" />
  <P N="bftA" V="G3FS2.bft" D="Width of the top flange of the I girder" />
  <P N="tftA" V="G3FS2.tft" D="Thickness of the top flange of the I girder" />
  <P N="bfbA" V="G3FS2.bfb" D="Width of the bottom flange of the I girder" />
  <P N="tfbA" V="G3FS2.tfb" D="Thickness of the bottom flange of the I girder" />
  <P N="dwB" V="G3FS3.dw" D="Web depth of the I girder" />
  <P N="twB" V="G3FS3.tw" D="Web thickness of the I girder" />
  <P N="bftB" V="G3FS3.bft" D="Width of the top flange of the I girder" />
  <P N="tftB" V="G3FS3.tft" D="Thickness of the top flange of the I girder" />
  <P N="bfbB" V="G3FS3.bfb" D="Width of the bottom flange of the I girder" />
  <P N="tfbB" V="G3FS3.tfb" D="Thickness of the bottom flange of the I girder" />
</O>
<O N="SG3G4" T="BoltedFieldSplice (BB)" X="G3FS3.StartStation" AlignV="Warp" AlignH="Orient" AlignT="None">
  <P N="gap" V="1/4" />
  <P N="sp_sta" V="G3FS3.Length" />
  <P N="dwA" V="G3FS3.dw" D="Web depth of the I girder" />
  <P N="twA" V="G3FS3.tw" D="Web thickness of the I girder" />
  <P N="bftA" V="G3FS3.bft" D="Width of the top flange of the I girder" />
  <P N="tftA" V="G3FS3.tft" D="Thickness of the top flange of the I girder" />
  <P N="bfbA" V="G3FS3.bfb" D="Width of the bottom flange of the I girder" />
  <P N="tfbA" V="G3FS3.tfb" D="Thickness of the bottom flange of the I girder" />
  <P N="dwB" V="G3FS4.dw" D="Web depth of the I girder" />
  <P N="twB" V="G3FS4.tw" D="Web thickness of the I girder" />
  <P N="bftB" V="G3FS4.bft" D="Width of the top flange of the I girder" />
  <P N="tftB" V="G3FS4.tft" D="Thickness of the top flange of the I girder" />
  <P N="bfbB" V="G3FS4.bfb" D="Width of the bottom flange of the I girder" />
  <P N="tfbB" V="G3FS4.tfb" D="Thickness of the bottom flange of the I girder" />
</O>
<O N="SG4G5" T="BoltedFieldSplice (BB)" X="G3FS4.StartStation" AlignV="Warp" AlignH="Orient" AlignT="None">
  <P N="gap" V="1/4" />
  <P N="sp_sta" V="G3FS4.Length" />
  <P N="dwA" V="G3FS4.dw" D="Web depth of the I girder" />
  <P N="twA" V="G3FS4.tw" D="Web thickness of the I girder" />
  <P N="bftA" V="G3FS4.bft" D="Width of the top flange of the I girder" />
  <P N="tftA" V="G3FS4.tft" D="Thickness of the top flange of the I girder" />
  <P N="bfbA" V="G3FS4.bfb" D="Width of the bottom flange of the I girder" />
  <P N="tfbA" V="G3FS4.tfb" D="Thickness of the bottom flange of the I girder" />
  <P N="dwB" V="G3FS5.dw" D="Web depth of the I girder" />
  <P N="twB" V="G3FS5.tw" D="Web thickness of the I girder" />
  <P N="bftB" V="G3FS5.bft" D="Width of the top flange of the I girder" />
  <P N="tftB" V="G3FS5.tft" D="Thickness of the top flange of the I girder" />
  <P N="bfbB" V="G3FS5.bfb" D="Width of the bottom flange of the I girder" />
  <P N="tfbB" V="G3FS5.tfb" D="Thickness of the bottom flange of the I girder" />
</O>

```

```

</O>
</O>
<O N="Girder 4" T="Group">
  <O N="G4FS1" T="SteelGirderMB" Z="-12.5" Y="-225" X="73487" AlignV="Warp" AlignH="Warp" AlignT="None">
    <P N="StartStation" V="G4FS1.X" />
    <P N="Offset" V="G4FS1.Y" />
    <P N="Length" V="1033" />
    <P N="dw" V="66" D="Web depth of the I girder" />
    <P N="tw" V="0.6875" D="Web thickness of the I girder" />
    <P N="bft" V="22" D="Width of the top flange of the I girder" />
    <P N="tft" V="1" D="Thickness of the top flange of the I girder" />
    <P N="bfb" V="22" D="Width of the bottom flange of the I girder" />
    <P N="tfb" V="1.25" D="Thickness of the bottom flange of the I girder" />
    <O N="StiffenerData" T="Group">
      <P N="WebStiffOrient" V="R" T="Text" D="Side of Web stiffened, L= Left, R = Right, B = Both" />
      <P N="WebStiffLoc" V="[73, 133, 193, 313, 373, 433, 553, 613, 673, 793, 853, 913, 1033]" D="Stiffener locations" />
    </O>
  </O>
  <P N="WebStiffT" V="0.625" D="Stiffener Plate Thickness" />
  <P N="WebStiffW" V="6" D="Stiffener Plate Width" />
  <P N="WebStiffHeight" V="dw" D="Jacking Stiffener Height" />
  <P N="WebStiffClipH" V="1.5" D="Jacking Stiffener Horizontal Clip" />
  <P N="WebStiffClipV" V="2.5" D="Jacking Stiffener Vertical Clip" />
  <P N="ConnStiffOrient" V="R" T="Text" D="Side of Web stiffened, L= Left, R = Right, B = Both" />
  <P N="ConnStiffLoc" V="[253, 493, 733, 973]" D="Connector Stiffener locations" />
  <P N="ConnStiffT" V="0.75" D="Connector Stiffener Thickness" />
  <P N="ConnStiffW" V="8" D="Connector Plate Width" />
  <P N="ConnStiffHeight" V="dw" D="Jacking Stiffener Height" />
  <P N="ConnStiffClipH" V="1.5" D="Jacking Stiffener Horizontal Clip" />
  <P N="ConnStiffClipV" V="2.5" D="Jacking Stiffener Vertical Clip" />
  <P N="BearingStiffOrient" V="B" T="Text" D="Side of Web stiffened, L= Left, R = Right, B = Both, N = None" />
  <P N="BearingStiffLoc" V="[13]" D="Bearing Stiffener locations" />
  <P N="BearingStiffT" V="0.75" D="Bearing Stiffener Thickness" />
  <P N="BearingStiffW" V="7.5" D="Bearing Plate Width" />
  <P N="BearingStiffHeight" V="dw" D="Jacking Stiffener Height" />
  <P N="BearingStiffClipH" V="1.5" D="Jacking Stiffener Horizontal Clip" />
  <P N="BearingStiffClipV" V="2.5" D="Jacking Stiffener Vertical Clip" />
  <P N="JackingStiffOrient" V="N" T="Text" D="Side of Web stiffened, L= Left, R = Right, B = Both, N = None" />
  </O>
</O>
<O N="G4FS2" T="SteelGirderMB" AlignH="Warp" AlignV="Warp" AlignT="None" X="74520" Y="-225" Z="-12.5">
  <P N="StartStation" V="G4FS2.X" />
  <P N="Offset" V="G4FS2.Y" />
  <P N="Length" V="1056" />
  <P N="dw" V="66" D="Web depth of the I girder" />
  <P N="tw" V="0.6875" D="Web thickness of the I girder" />
  <P N="bft" V="22" D="Width of the top flange of the I girder" />
  <P N="tft" V="[0,348], 1.25,[348,711], 2.5,[711,1056], 1.25]" D="Thickness of the top flange of the I girder" />
  <P N="bfb" V="22" D="Width of the bottom flange of the I girder" />
  <P N="tfb" V="[0,348], 1.625,[348,711], 3,[711,1056], 1.5]" D="Thickness of the bottom flange of the I girder" />
  <O N="StiffenerData" T="Group">
    <P N="WebStiffOrient" V="R" T="Text" D="Side of Web stiffened, L= Left, R = Right, B = Both" />
    <P N="WebStiffLoc" V="[60, 120, 240, 300, 420, 480, 600, 660, 780, 840, 960, 1020,]" D="Stiffener locations" />
    <P N="WebStiffT" V="0.625" D="Stiffener Plate Thickness" />
    <P N="WebStiffW" V="6" D="Stiffener Plate Width" />
    <P N="WebStiffHeight" V="dw" D="Jacking Stiffener Height" />
    <P N="WebStiffClipH" V="1.5" D="Jacking Stiffener Horizontal Clip" />
    <P N="WebStiffClipV" V="2.5" D="Jacking Stiffener Vertical Clip" />
  </O>
</O>

```

```

<P N="ConnStiffOrient" V="R" T="Text" D="Side of Web stiffened, L= Left, R = Right, B = Both" />
<P N="ConnStiffLoc" V="[180, 360, 720, 900]" D="Connector Stiffener locations" />
<P N="ConnStiffT" V="0.75" D="Connector Stiffener Thickness" />
<P N="ConnStiffW" V="8" D="Connector Plate Width" />
<P N="ConnStiffHeight" V="dw" D="Jacking Stiffener Height" />
<P N="ConnStiffClipH" V="1.5" D="Jacking Stiffener Horizontal Clip" />
<P N="ConnStiffClipV" V="2.5" D="Jacking Stiffener Vertical Clip" />
<P N="BearingStiffOrient" V="B" T="Text" D="Side of Web stiffened, L= Left, R = Right, B = Both, N = None" />
<P N="BearingStiffLoc" V="[540]" D="Bearing Stiffener locations" />
<P N="BearingStiffT" V="1" D="Bearing Stiffener Thickness" />
<P N="BearingStiffW" V="9" D="Bearing Plate Width" />
<P N="BearingStiffHeight" V="dw" D="Jacking Stiffener Height" />
<P N="BearingStiffClipH" V="1.5" D="Jacking Stiffener Horizontal Clip" />
<P N="BearingStiffClipV" V="2.5" D="Jacking Stiffener Vertical Clip" />
<P N="JackingStiffOrient" V="B" T="Text" D="Side of Web stiffened, L= Left, R = Right, B = Both, N = None" />
<P N="JackingStiffLoc" V="[516,564]" D="Jacking Stiffener locations" />
<P N="JackingStiffT" V="1" D="Jacking Stiffener Thickness" />
<P N="JackingStiffW" V="9" D="Jacking Plate Width" />
<P N="JackingStiffHeight" V="dw" D="Jacking Stiffener Height" />
<P N="JackingStiffClipH" V="1.5" D="Jacking Stiffener Horizontal Clip" />
<P N="JackingStiffClipV" V="2.5" D="Jacking Stiffener Vertical Clip" />
</O>
</O>
<O N="G4FS3" T="SteelGirderMB" AlignH="Warp" AlignV="Warp" AlignT="None" X="75576" Y="-225" Z="-12.5">
  <P N="StartStation" V="G4FS3.X" />
  <P N="Offset" V="G4FS3.Y" />
  <P N="Length" V="1128" />
  <P N="dw" V="66" D="Web depth of the I girder" />
  <P N="tw" V="0.6875" D="Web thickness of the I girder" />
  <P N="bft" V="20" D="Width of the top flange of the I girder" />
  <P N="tft" V="1" D="Thickness of the top flange of the I girder" />
  <P N="bfb" V="22" D="Width of the bottom flange of the I girder" />
  <P N="tfb" V="1.375" D="Thickness of the bottom flange of the I girder" />
  <O N="Stiffener Data" T="Group">
    <P N="WebStiffOrient" V="R" T="Text" D="Side of Web stiffened, L= Left, R = Right, B = Both" />
    <P N="WebStiffLoc" V="[24, 144, 204, 264, 384, 444, 504, 624, 684, 744, 864, 924, 984, 1104]" D="Stiffener
locations" />
    <P N="WebStiffT" V="0.625" D="Stiffener Plate Thickness" />
    <P N="WebStiffW" V="6" D="Stiffener Plate Width" />
    <P N="WebStiffHeight" V="dw" D="Jacking Stiffener Height" />
    <P N="WebStiffClipH" V="1.5" D="Jacking Stiffener Horizontal Clip" />
    <P N="WebStiffClipV" V="2.5" D="Jacking Stiffener Vertical Clip" />
    <P N="ConnStiffOrient" V="R" T="Text" D="Side of Web stiffened, L= Left, R = Right, B = Both" />
    <P N="ConnStiffLoc" V="[84, 324, 564, 804, 1044]" D="Connector Stiffener locations" />
    <P N="ConnStiffT" V="0.75" D="Connector Stiffener Thickness" />
    <P N="ConnStiffW" V="8" D="Connector Plate Width" />
    <P N="ConnStiffHeight" V="dw" D="Jacking Stiffener Height" />
    <P N="ConnStiffClipH" V="1.5" D="Jacking Stiffener Horizontal Clip" />
    <P N="ConnStiffClipV" V="2.5" D="Jacking Stiffener Vertical Clip" />
    <P N="BearingStiffOrient" V="N" T="Text" D="Side of Web stiffened, L= Left, R = Right, B = Both, N = None" />
    <P N="JackingStiffOrient" V="N" T="Text" D="Side of Web stiffened, L= Left, R = Right, B = Both, N = None" />
  </O>
</O>
</O>
<O N="G4FS4" T="SteelGirderMB" AlignH="Warp" AlignV="Warp" AlignT="None" X="76704" Y="-225" Z="-12.5">
  <P N="StartStation" V="G4FS4.X" />
  <P N="Offset" V="G4FS4.Y" />
  <P N="Length" V="1056" />

```

```

<P N="dw" V="66" D="Web depth of the I girder" />
<P N="tw" V="0.6875" D="Web thickness of the I girder" />
<P N="bft" V="20" D="Width of the top flange of the I girder" />
<P N="tft" V="[[0,342], 1.25,[342,702], 2.5,[702,1056], 1.25]" D="Thickness of the top flange of the I girder" />
<P N="bfb" V="20" D="Width of the bottom flange of the I girder" />
<P N="tfb" V="[[0,342], 1.625,[342,702], 3,[702,1056], 1.625]" D="Thickness of the bottom flange of the I girder" />
<O N="StiffenerData" T="Group">
  <P N="WebStiffOrient" V="R" T="Text" D="Side of Web stiffened, L= Left, R = Right, B = Both" />
  <P N="WebStiffLoc" V="[36, 96, 216, 276, 396, 456, 576, 636, 756, 816, 936, 996]" D="Stiffener locations" />
  <P N="WebStiffT" V="0.625" D="Stiffener Plate Thickness" />
  <P N="WebStiffW" V="6" D="Stiffener Plate Width" />
  <P N="WebStiffHeight" V="dw" D="Jacking Stiffener Height" />
  <P N="WebStiffClipH" V="1.5" D="Jacking Stiffener Horizontal Clip" />
  <P N="WebStiffClipV" V="2.5" D="Jacking Stiffener Vertical Clip" />
  <P N="ConnStiffOrient" V="R" T="Text" D="Side of Web stiffened, L= Left, R = Right, B = Both" />
  <P N="ConnStiffLoc" V="[156, 336, 696, 876]" D="Connector Stiffener locations" />
  <P N="ConnStiffT" V="0.75" D="Connector Stiffener Thickness" />
  <P N="ConnStiffW" V="8" D="Connector Plate Width" />
  <P N="ConnStiffHeight" V="dw" D="Jacking Stiffener Height" />
  <P N="ConnStiffClipH" V="1.5" D="Jacking Stiffener Horizontal Clip" />
  <P N="ConnStiffClipV" V="2.5" D="Jacking Stiffener Vertical Clip" />
  <P N="BearingStiffOrient" V="B" T="Text" D="Side of Web stiffened, L= Left, R = Right, B = Both, N = None" />
  <P N="BearingStiffLoc" V="[516]" D="Bearing Stiffener locations" />
  <P N="BearingStiffT" V="1" D="Bearing Stiffener Thickness" />
  <P N="BearingStiffW" V="9" D="Bearing Plate Width" />
  <P N="BearingStiffHeight" V="dw" D="Jacking Stiffener Height" />
  <P N="BearingStiffClipH" V="1.5" D="Jacking Stiffener Horizontal Clip" />
  <P N="BearingStiffClipV" V="2.5" D="Jacking Stiffener Vertical Clip" />
  <P N="JackingStiffOrient" V="B" T="Text" D="Side of Web stiffened, L= Left, R = Right, B = Both, N = None" />
  <P N="JackingStiffLoc" V="[492,540]" D="Jacking Stiffener locations" />
  <P N="JackingStiffT" V="1" D="Jacking Stiffener Thickness" />
  <P N="JackingStiffW" V="9" D="Jacking Plate Width" />
  <P N="JackingStiffHeight" V="dw" D="Jacking Stiffener Height" />
  <P N="JackingStiffClipH" V="1.5" D="Jacking Stiffener Horizontal Clip" />
  <P N="JackingStiffClipV" V="2.5" D="Jacking Stiffener Vertical Clip" />
</O>
</O>
<O N="G4FS5" T="SteelGirderMB" AlignH="Warp" AlignV="Warp" AlignT="None" X="77760" Y="-225" Z="-12.5">
  <P N="StartStation" V="G4FS5.X" />
  <P N="Offset" V="G4FS5.Y" />
  <P N="Length" V="1033" />
  <P N="dw" V="66" D="Web depth of the I girder" />
  <P N="tw" V="0.5" D="Web thickness of the I girder" />
  <P N="bft" V="16" D="Width of the top flange of the I girder" />
  <P N="tft" V="0.875" D="Thickness of the top flange of the I girder" />
  <P N="bfb" V="20" D="Width of the bottom flange of the I girder" />
  <P N="tfb" V="1.125" D="Thickness of the bottom flange of the I girder" />
  <O N="StiffenerData" T="Group">
    <P N="WebStiffOrient" V="R" T="Text" D="Side of Web stiffened, L= Left, R = Right, B = Both" />
    <P N="WebStiffLoc" V="[0, 60, 180, 240, 300, 360, 480, 540, 600, 660, 780, 840, 900, 960]" D="Stiffener locations"
  />
    <P N="WebStiffT" V="0.625" D="Stiffener Plate Thickness" />
    <P N="WebStiffW" V="6" D="Stiffener Plate Width" />
    <P N="WebStiffHeight" V="dw" D="Jacking Stiffener Height" />
    <P N="WebStiffClipH" V="1.5" D="Jacking Stiffener Horizontal Clip" />
    <P N="WebStiffClipV" V="2.5" D="Jacking Stiffener Vertical Clip" />
    <P N="ConnStiffOrient" V="R" T="Text" D="Side of Web stiffened, L= Left, R = Right, B = Both" />

```

```

<P N="ConnStiffLoc" V="[120, 420, 720]" D="Connector Stiffener locations" />
<P N="ConnStiffT" V="0.75" D="Connector Stiffener Thickness" />
<P N="ConnStiffW" V="8" D="Connector Plate Width" />
<P N="ConnStiffHeight" V="dw" D="Jacking Stiffener Height" />
<P N="ConnStiffClipH" V="1.5" D="Jacking Stiffener Horizontal Clip" />
<P N="ConnStiffClipV" V="2.5" D="Jacking Stiffener Vertical Clip" />
<P N="BearingStiffOrient" V="B" T="Text" D="Side of Web stiffened, L= Left, R = Right, B = Both, N = None" />
<P N="BearingStiffLoc" V="[1020, 1020]" D="Bearing Stiffener locations" />
<P N="BearingStiffW" V="7.5" D="Bearing Plate Width" />
<P N="BearingStiffT" V="0.75" D="Bearing Stiffener Thickness" />
<P N="BearingStiffHeight" V="dw" D="Jacking Stiffener Height" />
<P N="BearingStiffClipH" V="1.5" D="Jacking Stiffener Horizontal Clip" />
<P N="BearingStiffClipV" V="2.5" D="Jacking Stiffener Vertical Clip" />
<P N="JackingStiffOrient" V="N" T="Text" D="Side of Web stiffened, L= Left, R = Right, B = Both, N = None" />
</O>
</O>
<O N="G4 Splices" T="Group" Z="-12.5" Y="-225">
<O N="SG1G2" T="BoltedFieldSplice (BB)" X="G4FS1.StartStation" AlignV="Warp" AlignH="Orient" AlignT="None">
<P N="gap" V="1/4" />
<P N="sp_sta" V="G4FS1.Length" />
<P N="dwA" V="G4FS1.dw" D="Web depth of the I girder" />
<P N="twA" V="G4FS1.tw" D="Web thickness of the I girder" />
<P N="bftA" V="G4FS1.bft" D="Width of the top flange of the I girder" />
<P N="tftA" V="G4FS1.tft" D="Thickness of the top flange of the I girder" />
<P N="bfbA" V="G4FS1.bfb" D="Width of the bottom flange of the I girder" />
<P N="tfbA" V="G4FS1.tfb" D="Thickness of the bottom flange of the I girder" />
<P N="dwB" V="G4FS2.dw" D="Web depth of the I girder" />
<P N="twB" V="G4FS2.tw" D="Web thickness of the I girder" />
<P N="bftB" V="G4FS2.bft" D="Width of the top flange of the I girder" />
<P N="tftB" V="G4FS2.tft" D="Thickness of the top flange of the I girder" />
<P N="bfbB" V="G4FS2.bfb" D="Width of the bottom flange of the I girder" />
<P N="tfbB" V="G4FS2.tfb" D="Thickness of the bottom flange of the I girder" />
</O>
<O N="SG2G3" T="BoltedFieldSplice (BB)" X="G4FS2.StartStation" AlignV="Warp" AlignH="Orient" AlignT="None">
<P N="gap" V="1/4" />
<P N="sp_sta" V="G4FS2.Length" />
<P N="dwA" V="G4FS2.dw" D="Web depth of the I girder" />
<P N="twA" V="G4FS2.tw" D="Web thickness of the I girder" />
<P N="bftA" V="G4FS2.bft" D="Width of the top flange of the I girder" />
<P N="tftA" V="G4FS2.tft" D="Thickness of the top flange of the I girder" />
<P N="bfbA" V="G4FS2.bfb" D="Width of the bottom flange of the I girder" />
<P N="tfbA" V="G4FS2.tfb" D="Thickness of the bottom flange of the I girder" />
<P N="dwB" V="G4FS3.dw" D="Web depth of the I girder" />
<P N="twB" V="G4FS3.tw" D="Web thickness of the I girder" />
<P N="bftB" V="G4FS3.bft" D="Width of the top flange of the I girder" />
<P N="tftB" V="G4FS3.tft" D="Thickness of the top flange of the I girder" />
<P N="bfbB" V="G4FS3.bfb" D="Width of the bottom flange of the I girder" />
<P N="tfbB" V="G4FS3.tfb" D="Thickness of the bottom flange of the I girder" />
</O>
<O N="SG3G4" T="BoltedFieldSplice (BB)" X="G4FS3.StartStation" AlignV="Warp" AlignH="Orient" AlignT="None">
<P N="gap" V="1/4" />
<P N="sp_sta" V="G4FS3.Length" />
<P N="dwA" V="G4FS3.dw" D="Web depth of the I girder" />
<P N="twA" V="G4FS3.tw" D="Web thickness of the I girder" />
<P N="bftA" V="G4FS3.bft" D="Width of the top flange of the I girder" />
<P N="tftA" V="G4FS3.tft" D="Thickness of the top flange of the I girder" />
<P N="bfbA" V="G4FS3.bfb" D="Width of the bottom flange of the I girder" />

```

```

    <P N="tfbA" V="G4FS3.tfb" D="Thickness of the bottom flange of the I girder" />
    <P N="dwB" V="G4FS4.dw" D="Web depth of the I girder" />
    <P N="twB" V="G4FS4.tw" D="Web thickness of the I girder" />
    <P N="bftB" V="G4FS4.bft" D="Width of the top flange of the I girder" />
    <P N="tftB" V="G4FS4.tft" D="Thickness of the top flange of the I girder" />
    <P N="bfbB" V="G4FS4.bfb" D="Width of the bottom flange of the I girder" />
    <P N="tfbB" V="G4FS4.tfb" D="Thickness of the bottom flange of the I girder" />
  </O>
<O N="SG4G5" T="BoltedFieldSplice (BB)" X="G4FS4.StartStation" AlignV="Warp" AlignH="Orient" AlignT="None">
  <P N="gap" V="1/4" />
  <P N="sp_sta" V="G4FS4.Length" />
  <P N="dwA" V="G4FS4.dw" D="Web depth of the I girder" />
  <P N="twA" V="G4FS4.tw" D="Web thickness of the I girder" />
  <P N="bftA" V="G4FS4.bft" D="Width of the top flange of the I girder" />
  <P N="tftA" V="G4FS4.tft" D="Thickness of the top flange of the I girder" />
  <P N="bfbA" V="G4FS4.bfb" D="Width of the bottom flange of the I girder" />
  <P N="tfbA" V="G4FS4.tfb" D="Thickness of the bottom flange of the I girder" />
  <P N="dwB" V="G4FS5.dw" D="Web depth of the I girder" />
  <P N="twB" V="G4FS5.tw" D="Web thickness of the I girder" />
  <P N="bftB" V="G4FS5.bft" D="Width of the top flange of the I girder" />
  <P N="tftB" V="G4FS5.tft" D="Thickness of the top flange of the I girder" />
  <P N="bfbB" V="G4FS5.bfb" D="Width of the bottom flange of the I girder" />
  <P N="tfbB" V="G4FS5.tfb" D="Thickness of the bottom flange of the I girder" />
</O>
</O>
</O>
<O N="Shear Studs" T="Group">
  <O N="Girder 1 Shear Studs" T="Group" X="73487" Z="-12.5">
    <O T="Stud Placement" Y="117">
      <P N="dia_s" V="7/8" D="Diameter of the stud." />
      <P N="len_s" V="7" D="Length of stud." />
      <P N="Stud_Spacing" V="[15, 18, 15, 15, 18, 15, 15, 18, 15]" />
      <P N="Spacing_Length" V="[312, 1072, 156, 516, 1194, 432, 156, 1092, 312]" />
    </O>
    <O T="Stud Placement" Y="117-3.5">
      <P N="dia_s" V="7/8" D="Diameter of the stud." />
      <P N="len_s" V="7" D="Length of stud." />
      <P N="Stud_Spacing" V="[15, 18, 15, 15, 18, 15, 15, 18, 15]" />
      <P N="Spacing_Length" V="[312, 1072, 156, 516, 1194, 432, 156, 1092, 312]" />
    </O>
    <O T="Stud Placement" Y="117+3.5">
      <P N="dia_s" V="7/8" D="Diameter of the stud." />
      <P N="len_s" V="7" D="Length of stud." />
      <P N="Stud_Spacing" V="[15, 18, 15, 15, 18, 15, 15, 18, 15]" />
      <P N="Spacing_Length" V="[312, 1072, 156, 516, 1194, 432, 156, 1092, 312]" />
    </O>
  </O>
  <!--
<O N="Girder 2 Shear Studs" T="Group" X="73487" Z="-12.5">
  <O T="Stud Placement" Y="3">
    <P N="dia_s" V="7/8" D="Diameter of the stud." />
    <P N="len_s" V="7" D="Length of stud." />
    <P N="Stud_Spacing" V="[15, 18, 20, 18]" />
    <P N="Spacing_Length" V="[156, 1404, 2160, 1560]" />
  </O>
  <O T="Stud Placement" Y="3-3.5">

```

```

    <P N="dia_s" V="7/8" D="Diameter of the stud." />
    <P N="len_s" V="7" D="Length of stud." />
    <P N="Stud_Spacing" V="[15, 18, 20, 18]" />
    <P N="Spacing_Length" V="[156, 1404, 2160, 1560]" />
  </O>
  <O T="Stud Placement" Y="3+3.5">
    <P N="dia_s" V="7/8" D="Diameter of the stud." />
    <P N="len_s" V="7" D="Length of stud." />
    <P N="Stud_Spacing" V="[15, 18, 20, 18]" />
    <P N="Spacing_Length" V="[156, 1404, 2160, 1560]" />
  </O>
</O>
<O N="Girder 3 Shear Studs" T="Group" X="73487" Z="-12.5">
  <O T="Stud Placement" Y="-111">
    <P N="dia_s" V="7/8" D="Diameter of the stud." />
    <P N="len_s" V="7" D="Length of stud." />
    <P N="Stud_Spacing" V="[15, 18, 20, 18]" />
    <P N="Spacing_Length" V="[156, 1404, 2160, 1560]" />
  </O>
  <O T="Stud Placement" Y="-111-3.5">
    <P N="dia_s" V="7/8" D="Diameter of the stud." />
    <P N="len_s" V="7" D="Length of stud." />
    <P N="Stud_Spacing" V="[15, 18, 20, 18]" />
    <P N="Spacing_Length" V="[156, 1404, 2160, 1560]" />
  </O>
  <O T="Stud Placement" Y="-111+3.5">
    <P N="dia_s" V="7/8" D="Diameter of the stud." />
    <P N="len_s" V="7" D="Length of stud." />
    <P N="Stud_Spacing" V="[15, 18, 20, 18]" />
    <P N="Spacing_Length" V="[156, 1404, 2160, 1560]" />
  </O>
</O>
<O N="Girder 4 Shear Studs" T="Group" X="73487" Z="-12.5">
  <O T="Stud Placement" Y="-225">
    <P N="dia_s" V="7/8" D="Diameter of the stud." />
    <P N="len_s" V="7" D="Length of stud." />
    <P N="Stud_Spacing" V="[12, 18, 15, 15, 18, 15, 15, 18, 12]" />
    <P N="Spacing_Length" V="[324, 1118.25, 156, 432, 1330.5, 432, 156, 1092, 324]" />
  </O>
  <O T="Stud Placement" Y="-225-3.5">
    <P N="dia_s" V="7/8" D="Diameter of the stud." />
    <P N="len_s" V="7" D="Length of stud." />
    <P N="Stud_Spacing" V="[12, 18, 15, 15, 18, 15, 15, 18, 12]" />
    <P N="Spacing_Length" V="[324, 1118.25, 156, 432, 1330.5, 432, 156, 1092, 324]" />
  </O>
  <O T="Stud Placement" Y="-225+3.5">
    <P N="dia_s" V="7/8" D="Diameter of the stud." />
    <P N="len_s" V="7" D="Length of stud." />
    <P N="Stud_Spacing" V="[12, 18, 15, 15, 18, 15, 15, 18, 12]" />
    <P N="Spacing_Length" V="[324, 1118.25, 156, 432, 1330.5, 432, 156, 1092, 324]" />
  </O>
</O>
-->
</O>
<O N="Cross Frames" T="Group">
  <O N="CrossFrames" T="Group">
    <O N="CF1" T="Group">

```



```

<O N="Bay1" T="CrossFrameLayout" X="Abut1Sta-(ConnStiffT+thickness)/2">
  <P N="CrossFrameType" V="CrossFrameTypeKTop" T="Text" />
  <P N="CrossFrameLocations"
V="[240,480,720,960,1200,1380,1740,1920,2160,2400,2640,2880,3120,3360,3540,3900,4080,4380,4680,4980]" />
  <P N="StartStation" V="Bay1.X" />
  <P N="GirderA_Horiz_Offset" V="GirderOffset[1]" D="Girder A (Left) CL Offset from HCL" />
  <P N="GirderB_Horiz_Offset" V="GirderOffset[0]" D="Girder B (Right) CL Offset from HCL" />
  <P N="WebDepth" V="66" />
  <P N="TopWP_Vert_Offset" V="10" D="Top Work Point offset from top of Girder web" />
  <P N="TopWP_Horiz_Offset" V="0" D="Top Work Point offset from CL of Girder web" />
  <P N="BotWP_Vert_Offset" V="7.5" D="Bottom Work Point offset from bottom of Girder web" />
  <P N="BotWP_Horiz_Offset" V="0" D="Bottom Work Point offset from CL of Girder web" />
  <P N="BoltDia" V="0.75" D="Diameter of bolt" />
  <P N="EdgeDist" V="1.75" D="Distance from edge of Plate to CL of Bolt Hole" />
  <P N="ConnStiffT" V="0.75" D="Connector Stiffener Thickness" />
  <O N="Cross Frame Member Data" T="Group">
    <P N="TopChord" V="L5X5X1over2" T="Section" />
    <P N="BotChord" V="L5X5X1over2" T="Section" />
    <P N="Diagonal" V="L5X5X1over2" T="Section" />
  </O>
  <O N="Gusset Plate Data" T="Group">
    <P N="TopGusset_H" V="14" />
    <P N="TopGusset_V" V="9.5" />
    <P N="TopBoltGroupCols" V="2" D="number of cols" />
    <P N="TopBoltGroupRows" V="3" D="number of rows" />
    <P N="TopBoltGroupSpY" V="3" D="Horiz spacing between columns" />
    <P N="TopBoltGroupSpZ" V="3" D="Vert spacing between rows" />
    <P N="BottomGusset_H" V="14" />
    <P N="BottomGusset_V" V="15.5" />
    <P N="BottomBoltGroupCols" V="2" D="number of cols" />
    <P N="BottomBoltGroupRows" V="5" D="number of rows" />
    <P N="BottomBoltGroupSpY" V="3" D="Horiz spacing between columns" />
    <P N="BottomBoltGroupSpZ" V="3" D="Vert spacing between rows" />
    <P N="CenterGusset_H" V="20" />
    <P N="CenterGusset_V" V="12" />
    <P N="thickness" V="0.5" D="thickness of the plate" />
  </O>
</O>
<O N="Bay2" T="CrossFrameLayout" X="Abut1Sta-(ConnStiffT+thickness)/2">
  <P N="CrossFrameType" V="CrossFrameTypeKTop" T="Text" />
  <P N="CrossFrameLocations"
V="[240,480,720,960,1200,1380,1740,1920,2160,2400,2640,2880,3120,3360,3540,3900,4080,4380,4680,4980]" />
  <P N="StartStation" V="Bay1.X" />
  <P N="GirderA_Horiz_Offset" V="GirderOffset[2]" D="Girder A (Left) CL Offset from HCL" />
  <P N="GirderB_Horiz_Offset" V="GirderOffset[1]" D="Girder B (Right) CL Offset from HCL" />
  <P N="WebDepth" V="66" />
  <P N="TopWP_Vert_Offset" V="10" D="Top Work Point offset from top of Girder web" />
  <P N="TopWP_Horiz_Offset" V="0" D="Top Work Point offset from CL of Girder web" />
  <P N="BotWP_Vert_Offset" V="7.5" D="Bottom Work Point offset from bottom of Girder web" />
  <P N="BotWP_Horiz_Offset" V="0" D="Bottom Work Point offset from CL of Girder web" />
  <P N="BoltDia" V="0.75" D="Diameter of bolt" />
  <P N="EdgeDist" V="1.75" D="Distance from edge of Plate to CL of Bolt Hole" />
  <P N="ConnStiffT" V="0.75" D="Connector Stiffener Thickness" />
  <O N="Cross Frame Member Data" T="Group">
    <P N="TopChord" V="L5X5X1over2" T="Section" />
    <P N="BotChord" V="L5X5X1over2" T="Section" />
    <P N="Diagonal" V="L5X5X1over2" T="Section" />
  </O>

```

```

</O>
<O N="Gusset Plate Data" T="Group">
  <P N="TopGusset_H" V="14" />
  <P N="TopGusset_V" V="9.5" />
  <P N="TopBoltGroupCols" V="2" D="number of cols" />
  <P N="TopBoltGroupRows" V="3" D="number of rows" />
  <P N="TopBoltGroupSpY" V="3" D="Horiz spacing between columns" />
  <P N="TopBoltGroupSpZ" V="3" D="Vert spacing between rows" />
  <P N="BottomGusset_H" V="14" />
  <P N="BottomGusset_V" V="15.5" />
  <P N="BottomBoltGroupCols" V="2" D="number of cols" />
  <P N="BottomBoltGroupRows" V="5" D="number of rows" />
  <P N="BottomBoltGroupSpY" V="3" D="Horiz spacing between columns" />
  <P N="BottomBoltGroupSpZ" V="3" D="Vert spacing between rows" />
  <P N="CenterGusset_H" V="20" />
  <P N="CenterGusset_V" V="12" />
  <P N="thickness" V="0.5" D="thickness of the plate" />
</O>
</O>
<O N="Bay3" T="CrossFrameLayout" X="Abut1Sta-(ConnStiffT+thickness)/2">
  <P N="CrossFrameType" V="CrossFrameTypeKTop" T="Text" />
  <P N="CrossFrameLocations"
V="[240,480,720,960,1200,1380,1740,1920,2160,2400,2640,2880,3120,3360,3540,3900,4080,4380,4680,4980]" />
  <P N="StartStation" V="Bay1.X" />
  <P N="GirderA_Horiz_Offset" V="GirderOffset[3]" D="Girder A (Left) CL Offset from HCL" />
  <P N="GirderB_Horiz_Offset" V="GirderOffset[2]" D="Girder B (Right) CL Offset from HCL" />
  <P N="WebDepth" V="66" />
  <P N="TopWP_Vert_Offset" V="10" D="Top Work Point offset from top of Girder web" />
  <P N="TopWP_Horiz_Offset" V="0" D="Top Work Point offset from CL of Girder web" />
  <P N="BotWP_Vert_Offset" V="7.5" D="Bottom Work Point offset from bottom of Girder web" />
  <P N="BotWP_Horiz_Offset" V="0" D="Bottom Work Point offset from CL of Girder web" />
  <P N="BoltDia" V="0.75" D="Diameter of bolt" />
  <P N="EdgeDist" V="1.75" D="Distance from edge of Plate to CL of Bolt Hole" />
  <P N="ConnStiffT" V="0.75" D="Connector Stiffener Thickness" />
  <O N="Cross Frame Member Data" T="Group">
    <P N="TopChord" V="L5X5X1over2" T="Section" />
    <P N="BotChord" V="L5X5X1over2" T="Section" />
    <P N="Diagonal" V="L5X5X1over2" T="Section" />
  </O>
  <O N="Gusset Plate Data" T="Group">
    <P N="TopGusset_H" V="14" />
    <P N="TopGusset_V" V="9.5" />
    <P N="TopBoltGroupCols" V="2" D="number of cols" />
    <P N="TopBoltGroupRows" V="3" D="number of rows" />
    <P N="TopBoltGroupSpY" V="3" D="Horiz spacing between columns" />
    <P N="TopBoltGroupSpZ" V="3" D="Vert spacing between rows" />
    <P N="BottomGusset_H" V="14" />
    <P N="BottomGusset_V" V="15.5" />
    <P N="BottomBoltGroupCols" V="2" D="number of cols" />
    <P N="BottomBoltGroupRows" V="5" D="number of rows" />
    <P N="BottomBoltGroupSpY" V="3" D="Horiz spacing between columns" />
    <P N="BottomBoltGroupSpZ" V="3" D="Vert spacing between rows" />
    <P N="CenterGusset_H" V="20" />
    <P N="CenterGusset_V" V="12" />
    <P N="thickness" V="0.5" D="thickness of the plate" />
  </O>
</O>

```

```

</O>
<O N="CF2" T="Group">
  <O N="Bay1" T="CrossFrameLayout" X="Abut1Sta-(BearingStiffT+thickness)/2">
    <P N="CrossFrameType" V="CrossFrameTypeKTop" T="Text" />
    <P N="CrossFrameLocations" V="[1560,3720]" />
    <P N="StartStation" V="Bay1.X" />
    <P N="GirderA_Horiz_Offset" V="GirderOffset[1]" D="Girder A (Left) CL Offset from HCL" />
    <P N="GirderB_Horiz_Offset" V="GirderOffset[0]" D="Girder B (Right) CL Offset from HCL" />
    <P N="WebDepth" V="66" />
    <P N="TopWP_Vert_Offset" V="10" D="Top Work Point offset from top of Girder web" />
    <P N="TopWP_Horiz_Offset" V="0" D="Top Work Point offset from CL of Girder web" />
    <P N="BotWP_Vert_Offset" V="7.5" D="Bottom Work Point offset from bottom of Girder web" />
    <P N="BotWP_Horiz_Offset" V="0" D="Bottom Work Point offset from CL of Girder web" />
    <P N="BoltDia" V="0.75" D="Diameter of bolt" />
    <P N="EdgeDist" V="1.75" D="Distance from edge of Plate to CL of Bolt Hole" />
    <P N="BearingStiffT" V="1" D="Connector Stiffener Thickness" />
    <O N="Cross Frame Member Data" T="Group">
      <P N="TopChord" V="L5X5X1over2" T="Section" />
      <P N="BotChord" V="L5X5X1over2" T="Section" />
      <P N="Diagonal" V="L5X5X1over2" T="Section" />
    </O>
  </O>
  <O N="Gusset Plate Data" T="Group">
    <P N="TopGusset_H" V="14" />
    <P N="TopGusset_V" V="9.5" />
    <P N="TopBoltGroupCols" V="2" D="number of cols" />
    <P N="TopBoltGroupRows" V="3" D="number of rows" />
    <P N="TopBoltGroupSpY" V="3" D="Horiz spacing between columns" />
    <P N="TopBoltGroupSpZ" V="3" D="Vert spacing between rows" />
    <P N="BottomGusset_H" V="14" />
    <P N="BottomGusset_V" V="15.5" />
    <P N="BottomBoltGroupCols" V="2" D="number of cols" />
    <P N="BottomBoltGroupRows" V="5" D="number of rows" />
    <P N="BottomBoltGroupSpY" V="3" D="Horiz spacing between columns" />
    <P N="BottomBoltGroupSpZ" V="3" D="Vert spacing between rows" />
    <P N="CenterGusset_H" V="20" />
    <P N="CenterGusset_V" V="12" />
    <P N="thickness" V="0.5" D="thickness of the plate" />
  </O>
</O>
<O N="Bay2" T="CrossFrameLayout" X="Abut1Sta-(BearingStiffT+thickness)/2">
  <P N="CrossFrameType" V="CrossFrameTypeKTop" T="Text" />
  <P N="CrossFrameLocations" V="[1560,3720]" />
  <P N="StartStation" V="Bay1.X" />
  <P N="GirderA_Horiz_Offset" V="GirderOffset[2]" D="Girder A (Left) CL Offset from HCL" />
  <P N="GirderB_Horiz_Offset" V="GirderOffset[1]" D="Girder B (Right) CL Offset from HCL" />
  <P N="WebDepth" V="66" />
  <P N="TopWP_Vert_Offset" V="10" D="Top Work Point offset from top of Girder web" />
  <P N="TopWP_Horiz_Offset" V="0" D="Top Work Point offset from CL of Girder web" />
  <P N="BotWP_Vert_Offset" V="7.5" D="Bottom Work Point offset from bottom of Girder web" />
  <P N="BotWP_Horiz_Offset" V="0" D="Bottom Work Point offset from CL of Girder web" />
  <P N="BoltDia" V="0.75" D="Diameter of bolt" />
  <P N="EdgeDist" V="1.75" D="Distance from edge of Plate to CL of Bolt Hole" />
  <P N="BearingStiffT" V="1" D="Connector Stiffener Thickness" />
  <O N="Cross Frame Member Data" T="Group">
    <P N="TopChord" V="L5X5X1over2" T="Section" />
    <P N="BotChord" V="L5X5X1over2" T="Section" />
    <P N="Diagonal" V="L5X5X1over2" T="Section" />
  </O>

```

```

</O>
<O N="Gusset Plate Data" T="Group">
  <P N="TopGusset_H" V="14" />
  <P N="TopGusset_V" V="9.5" />
  <P N="TopBoltGroupCols" V="2" D="number of cols" />
  <P N="TopBoltGroupRows" V="3" D="number of rows" />
  <P N="TopBoltGroupSpY" V="3" D="Horiz spacing between columns" />
  <P N="TopBoltGroupSpZ" V="3" D="Vert spacing between rows" />
  <P N="BottomGusset_H" V="14" />
  <P N="BottomGusset_V" V="15.5" />
  <P N="BottomBoltGroupCols" V="2" D="number of cols" />
  <P N="BottomBoltGroupRows" V="5" D="number of rows" />
  <P N="BottomBoltGroupSpY" V="3" D="Horiz spacing between columns" />
  <P N="BottomBoltGroupSpZ" V="3" D="Vert spacing between rows" />
  <P N="CenterGusset_H" V="20" />
  <P N="CenterGusset_V" V="12" />
  <P N="thickness" V="0.5" D="thickness of the plate" />
</O>
</O>
<O N="Bay3" T="CrossFrameLayout" X="Abut1Sta-(BearingStiffT+thickness)/2">
  <P N="CrossFrameType" V="CrossFrameTypeKTop" T="Text" />
  <P N="CrossFrameLocations" V="[1560,3720]" />
  <P N="StartStation" V="Bay1.X" />
  <P N="GirderA_Horiz_Offset" V="GirderOffset[3]" D="Girder A (Left) CL Offset from HCL" />
  <P N="GirderB_Horiz_Offset" V="GirderOffset[2]" D="Girder B (Right) CL Offset from HCL" />
  <P N="WebDepth" V="66" />
  <P N="TopWP_Vert_Offset" V="10" D="Top Work Point offset from top of Girder web" />
  <P N="TopWP_Horiz_Offset" V="0" D="Top Work Point offset from CL of Girder web" />
  <P N="BotWP_Vert_Offset" V="7.5" D="Bottom Work Point offset from bottom of Girder web" />
  <P N="BotWP_Horiz_Offset" V="0" D="Bottom Work Point offset from CL of Girder web" />
  <P N="BoltDia" V="0.75" D="Diameter of bolt" />
  <P N="EdgeDist" V="1.75" D="Distance from edge of Plate to CL of Bolt Hole" />
  <P N="BearingStiffT" V="1" D="Connector Stiffener Thickness" />
  <O N="Cross Frame Member Data" T="Group">
    <P N="TopChord" V="L5X5X1over2" T="Section" />
    <P N="BotChord" V="L5X5X1over2" T="Section" />
    <P N="Diagonal" V="L5X5X1over2" T="Section" />
  </O>
  <O N="Gusset Plate Data" T="Group">
    <P N="TopGusset_H" V="14" />
    <P N="TopGusset_V" V="9.5" />
    <P N="TopBoltGroupCols" V="2" D="number of cols" />
    <P N="TopBoltGroupRows" V="3" D="number of rows" />
    <P N="TopBoltGroupSpY" V="3" D="Horiz spacing between columns" />
    <P N="TopBoltGroupSpZ" V="3" D="Vert spacing between rows" />
    <P N="BottomGusset_H" V="14" />
    <P N="BottomGusset_V" V="15.5" />
    <P N="BottomBoltGroupCols" V="2" D="number of cols" />
    <P N="BottomBoltGroupRows" V="5" D="number of rows" />
    <P N="BottomBoltGroupSpY" V="3" D="Horiz spacing between columns" />
    <P N="BottomBoltGroupSpZ" V="3" D="Vert spacing between rows" />
    <P N="CenterGusset_H" V="20" />
    <P N="CenterGusset_V" V="12" />
    <P N="thickness" V="0.5" D="thickness of the plate" />
  </O>
</O>
</O>

```

```

</O>
<O N="Diaphragm 1" T="Group" AlignH="Orient" AlignV="None" AlignT="None" X="Abut1Sta" Z="-12.5">
  <O N="G1G2" T="Diaphragm" Y="117">
    <P N="Length" V="9*12+6" D="Length between CL of girders." />
    <P N="bc" V="7" D="Bottom Flange minimum clearance. " Role="Input" Category="Diaphragm Section Data" />
    <P N="tc" V="-1" D="Top Flange clearance. " Role="Input" Category="Diaphragm Section Data" />
    <P N="tw" V="5/8" D="Web thickness " Role="Input" Category="Diaphragm Section Data" />
    <P N="tfb" V="10" D="Width of the top flange " Role="Input" Category="Diaphragm Section Data" />
    <P N="tft" V="3/4" D="Thickness of the top flange of the I girder" Role="Input" Category="Diaphragm Section Data" />
  />
  <P N="bfb" V="10" D="Width of the bottom flange of the I girder" Role="Input" Category="Diaphragm Section Data" />
  />
  <P N="bft" V="3/4" D="Thickness of the bottom flange of the I girder" Role="Input" Category="Diaphragm Section Data" />
  />
  <P N="gwpL" V="5.58" D="Girder Work Point Elevation, Left Side" Role="Input" Category="Diaphragm Section Data" />
  />
  <P N="gwpR" V="0" D="Girder Work Point Elevation, Right Side" Role="Input" Category="Diaphragm Section Data" />
  <P N="gd" V="66" D="Girder Depth" Role="Input" Category="Diaphragm Section Data" />
  <P N="bsw" V="7.5" D="Bearing Stiffener Width" Role="Input" Category="Diaphragm Section Data" />
  <P N="gap" V="0.5" D="Gap between bearing stiffener and diaphragm." Role="Input" Category="Diaphragm Section Data" />
  />
  <P N="fpt" V="1/16" D="Fill Plate Thickness" Role="Input" Category="Plate" />
  <P N="fpb" V="6.5" D="Fill Plate Width" Role="Input" Category="Plate" />
  <P N="spt" V="3/8" D="Splice Plate Thickness" Role="Input" Category="Plate" />
  <P N="spb" V="13.5" D="Splice Plate Width" Role="Input" Category="Plate" />
  <P N="nR" V="11" D="Number of Bolt Hole Rows " Role="Input" Category="Plate" />
  <P N="nC" V="4" D="Number of Bolt Hole Columns " Role="Input" Category="Plate" />
  <P N="spc" V="2" D="Splice Plate Clearance" Role="Input" Category="Plate" />
  <P N="spH" V="3" D="Horiz spacing between columns" />
  <P N="spW" V="3" D="Center column space" />
  <P N="dia" V="7/8" D="Bolt Diameter" />
  <P N="edge" V="1.75" D="Distance from edge of Plate to CL of Bolt Hole" />
  <P N="JackingStiffOrient" V="B" T="Text" D="Side of Web stiffened, L = Left, R = Right, B = Both N = None" />
  <P N="JackingStiffT" V="1.75" D="Jacking Stiffener Thickness" />
  <P N="JackingStiffW" V="4" D="Jacking Stiffener Width" />
  <P N="JackingStiffHeight" V="gd-bc-tc-tft-bft" D="Jacking Stiffener Height" />
  <P N="JackingStiffClipH" V="1.5" D="Jacking Stiffener Horizontal Clip" />
  <P N="JackingStiffClipV" V="2.5" D="Jacking Stiffener Vertical Clip" />
  <P N="JackingStiffLoc" V="[Length/2]" D="Jacking Stiffener Locations" />
  />
  <O N="G2G3" T="Diaphragm" Extends="G1G2" Y="3">
    <P N="bc" V="-1" D="Bottom Flange minimum clearance. " Role="Input" Category="Diaphragm Section Data" />
    <P N="tc" V="8" D="Top Flange clearance. " Role="Input" Category="Diaphragm Section Data" />
    <P N="gwpL" V="9.12" D="Girder Work Point Elevation, Left Side" Role="Input" Category="Diaphragm Section Data" />
  />
  />
  <O N="G3G4" T="Diaphragm" Extends="G2G3" Y="-111">
    <P N="gwpL" V="0" D="Girder Work Point Elevation, Left Side" Role="Input" Category="Diaphragm Section Data" />
    <P N="gwpR" V="-9.12" D="Girder Work Point Elevation, Right Side" Role="Input" Category="Diaphragm Section Data" />
  />
  />
  <O N="Diaphragm 2" T="Group" AlignH="Orient" AlignV="None" AlignT="None" X="Abut1Sta+5280" Z="-12.5">
    <O N="G1G2" T="Diaphragm" Y="117">
      <P N="Length" V="9*12+6" D="Length between CL of girders." />
      <P N="bc" V="3" D="Bottom Flange minimum clearance. " Role="Input" Category="Diaphragm Section Data" />
      <P N="tc" V="4" D="Top Flange clearance. " Role="Input" Category="Diaphragm Section Data" />
    />
  />

```

```

    <P N="tw" V="5/8" D="Web thickness " Role="Input" Category="Diaphragm Section Data" />
    <P N="tfb" V="10" D="Width of the top flange " Role="Input" Category="Diaphragm Section Data" />
    <P N="tft" V="3/4" D="Thickness of the top flange of the I girder" Role="Input" Category="Diaphragm Section Data" />
  />
    <P N="bfb" V="10" D="Width of the bottom flange of the I girder" Role="Input" Category="Diaphragm Section Data" />
  />
    <P N="bft" V="3/4" D="Thickness of the bottom flange of the I girder" Role="Input" Category="Diaphragm Section Data" />
    <P N="gwpL" V="1.48+0.26" D="Girder Work Point Elevation, Left Side" Role="Input" Category="Diaphragm Section Data" />
    <P N="gwpR" V="1.48" D="Girder Work Point Elevation, Right Side" Role="Input" Category="Diaphragm Section Data" />
    <P N="gd" V="66" D="Girder Depth" Role="Input" Category="Diaphragm Section Data" />
    <P N="bsw" V="7.5" D="Bearing Stiffener Width" Role="Input" Category="Diaphragm Section Data" />
    <P N="gap" V="0.5" D="Gap between bearing stiffener and diaphragm." Role="Input" Category="Diaphragm Section Data" />
    <P N="fpt" V="1/16" D="Fill Plate Thickness" Role="Input" Category="Plate" />
    <P N="fpb" V="6.5" D="Fill Plate Width" Role="Input" Category="Plate" />
    <P N="spt" V="3/8" D="Splice Plate Thickness" Role="Input" Category="Plate" />
    <P N="spb" V="13.5" D="Splice Plate Width" Role="Input" Category="Plate" />
    <P N="nR" V="11" D="Number of Bolt Hole Rows " Role="Input" Category="Plate" />
    <P N="nC" V="4" D="Number of Bolt Hole Columns " Role="Input" Category="Plate" />
    <P N="spc" V="2" D="Splice Plate Clearance" Role="Input" Category="Plate" />
    <P N="spH" V="3" D="Horiz spacing between columns" />
    <P N="spW" V="3" D="Center column space" />
    <P N="dia" V="7/8" D="Bolt Diameter" />
    <P N="edge" V="1.75" D="Distance from edge of Plate to CL of Bolt Hole" />
    <P N="JackingStiffOrient" V="B" T="Text" D="Side of Web stiffened, L= Left, R= Right, B= Both N= None" />
    <P N="JackingStiffT" V="1.75" D="Jacking Stiffener Thickness" />
    <P N="JackingStiffW" V="4" D="Jacking Stiffener Width" />
    <P N="JackingStiffHeight" V="gd-bc-tc-tft-bft" D="Jacking Stiffener Height" />
    <P N="JackingStiffClipH" V="1.5" D="Jacking Stiffener Horizontal Clip" />
    <P N="JackingStiffClipV" V="2.5" D="Jacking Stiffener Vertical Clip" />
    <P N="JackingStiffLoc" V="[Length/2]" D="Jacking Stiffener Locations" />
  </O>
  <O N="G2G3" T="Diaphragm" Extends="G1G2" Y="3">
    <P N="bc" V="3" D="Bottom Flange minimum clearance. " Role="Input" Category="Diaphragm Section Data" />
    <P N="tc" V="4" D="Top Flange clearance. " Role="Input" Category="Diaphragm Section Data" />
    <P N="gwpL" V="1.48" D="Girder Work Point Elevation, Left Side" Role="Input" Category="Diaphragm Section Data" />
  />
    <P N="gwpR" V="-1.48" D="Girder Work Point Elevation, Right Side" Role="Input" Category="Diaphragm Section Data" />
  </O>
  <O N="G3G4" T="Diaphragm" Extends="G2G3" Y="-111">
    <P N="bc" V="3" D="Bottom Flange minimum clearance. " Role="Input" Category="Diaphragm Section Data" />
    <P N="tc" V="4" D="Top Flange clearance. " Role="Input" Category="Diaphragm Section Data" />
    <P N="gwpL" V="-1.48" D="Girder Work Point Elevation, Left Side" Role="Input" Category="Diaphragm Section Data" />
  />
    <P N="gwpR" V="-4.44" D="Girder Work Point Elevation, Right Side" Role="Input" Category="Diaphragm Section Data" />
  </O>
</O>
<O N="Deck" T="Group" AlignT="Warp" AlignH="Warp" AlignV="Warp">
  <P N="DeckWidth" V="436.5" />
  <P N="MinDeck_t" V="8.5" />
  <P N="TopDeckToTopGirderWeb" V="12.5" />

```

```

<P N="LeftDeck_t" V="10" />
<P N="RightDeck_t" V="10" />
<P N="LeftOverhangType" V="1" />
<P N="RightOverhangType" V="1" />
<P N="LeftEdge" V="272.25" />
<P N="GirderOffset" V="[117, 3, -111, -225]" />
<P N="HaunchWidth" V="[18, 16, 16, 22]" />
<O N="DeckPour1" T="Deck">
  <P N="StartStation" V="73525.75" />
  <P N="EndStation" V="74520" />
</O>
<O N="DeckPour4" T="Deck">
  <P N="StartStation" V="74520" />
  <P N="EndStation" V="75585" />
</O>
<O N="DeckPour3" T="Deck">
  <P N="StartStation" V="75585" />
  <P N="EndStation" V="76695" />
</O>
<O N="DeckPour5" T="Deck">
  <P N="StartStation" V="76695" />
  <P N="EndStation" V="77760" />
</O>
<O N="DeckPour2" T="Deck">
  <P N="StartStation" V="77760" />
  <P N="EndStation" V="78754.25" />
</O>
<O N="DeckPour6a" T="DeckEndBeam">
  <P N="EndBeamCLStation" V="Abut1Sta" />
  <P N="EndBeamPosition" V="0" T="Text" D="End Beam Position (0=Back Station, 1=Ahead Station)" />
  <P N="EndBeamDepth" V="17.25" />
  <P N="EndBeamDepthLeft" V="15.25" />
  <P N="EndBeamDepthRight" V="15.25" />
  <P N="EndBeamWidth" V="27.75" />
  <P N="EndBeamOverhang" V="16.75" />
  <P N="TransitionLength" V="8.75" />
  <P N="TypDeckLength" V="6" />
</O>
<O N="DeckPour6b" T="DeckEndBeam">
  <P N="EndBeamCLStation" V="Abut2Sta" />
  <P N="EndBeamPosition" V="1" T="Text" D="End Beam Position (0=Back Station, 1=Ahead Station)" />
  <P N="EndBeamDepth" V="17.25" />
  <P N="EndBeamDepthLeft" V="15.25" />
  <P N="EndBeamDepthRight" V="15.25" />
  <P N="EndBeamWidth" V="27.75" />
  <P N="EndBeamOverhang" V="15.75" />
  <P N="TransitionLength" V="8.75" />
  <P N="TypDeckLength" V="6" />
</O>
</O>
<O N="Bridge Rail" T="Group" AlignH="Warp" AlignV="Warp" Z="-0.75">
  <O T="PA Turnpike Barrier New">
    <P N="Station" V="Abut1Sta-16.75" />
    <P N="Length" V="5313" />
    <P N="Offset" V="144" />
    <P N="type" V="RIGHT" />
  </O>
</O>

```

APPENDIX B – EXAMPLE BRIDGE MODEL

```
<O T="PA Turnpike Barrier New">  
  <P N="Station" V="Abut1Sta-16.75" />  
  <P N="Length" V="5313" />  
  <P N="Offset" V="-252" />  
  <P N="type" V="LEFT" />  
</O>  
</O>  
</O>  
</O>
```