

Florida Demonstration Project: Precast Concrete Pavement System on US 92

**Final Report
April 2014**

HIGHWAYS FOR LIFE

Accelerating Innovation for the American Driving Experience.



U.S. Department of Transportation
Federal Highway Administration

FOREWORD

The purpose of the Highways for LIFE (HfL) pilot program is to accelerate the use of innovations that improve highway safety and quality while reducing congestion caused by construction. **LIFE** is an acronym for **L**onger-lasting highway infrastructure using **I**nnovations to accomplish the **F**ast construction of **E**fficient and safe highways and bridges.

Specifically, HfL focuses on speeding up the widespread adoption of proven innovations in the highway community. Such “innovations” encompass technologies, materials, tools, equipment, procedures, specifications, methodologies, processes, and practices used to finance, design, or construct highways. HfL is based on the recognition that innovations are available that, if widely and rapidly implemented, would result in significant benefits to road users and highway agencies.

Although innovations themselves are important, HfL is as much about changing the highway community’s culture from one that considers innovation something that only adds to the workload, delays projects, raises costs, or increases risk to one that sees it as an opportunity to provide better highway transportation service. HfL is also an effort to change the way highway community decision makers and participants perceive their jobs and the service they provide.

The HfL pilot program, described in Safe, Accountable, Flexible, Efficient Transportation Equity Act: A Legacy for Users (SAFETEA-LU) Section 1502, includes funding for demonstration construction projects. By providing incentives for projects, HfL promotes improvements in safety, construction-related congestion, and quality that can be achieved through the use of performance goals and innovations. This report documents one such HfL demonstration project.

Additional information on the HfL program is at www.fhwa.dot.gov/hfl.

NOTICE

This document is disseminated under the sponsorship of the U.S. Department of Transportation in the interest of information exchange. The U.S. Government assumes no liability for its contents or use thereof. This report does not constitute a standard, specification, or regulation.

The U.S. Government does not endorse products or manufacturers. Trade and manufacturers’ names appear in this report only because they are considered essential to the object of the document.

1. Report No.	2. Government Accession No	3. Recipient's Catalog No	
3. Title and Subtitle Florida Demonstration Project: Precast Concrete Pavement System on US 92		5. Report Date April 2014	6. Performing Organization Code
7. Authors Paul Littleton and Jagannath Mallela		8. Performing Organization Report No.	
9. Performing Organization Name and Address Applied Research Associates, Inc. 100 Trade Centre Drive, Suite 200 Champaign, IL 61820		10. Work Unit No. (TRAIS) C6B	11. Contract or Grant No.
12. Sponsoring Agency Name and Address Office of Infrastructure Federal Highway Administration 1200 New Jersey Avenue, SE Washington, DC 20590		13. Type of Report and Period Covered Final Report July 2011–August 2012	14. Sponsoring Agency Code
15. Supplementary Notes Contracting Officer's Representative: Julie Zirlin Contracting Officer's Task Manager: Ewa Flom			
16. Abstract As part of a national initiative sponsored by the Federal Highway Administration under the Highways for LIFE program, the Florida Department of Transportation (FDOT) was awarded a \$1 million grant to demonstrate the use of a proven, innovative precast concrete pavement system in conjunction with traditional pavement restoration and concrete overlay on an important multilane highway. The project represents FDOT's effort to introduce to the central Florida highway industry the precast concrete pavement systems, a construction option that is easy to build, easy to install, easy to maintain, and will have a long service life. This report details the installation of precast concrete panels to rehabilitate existing problem areas and to raise the profile of the roadway to reduce the occurrence of flooding. This report also contains other items relevant to HfL projects, including a description of HfL goals, other technology transfer activities on the project, and an analysis of data to evaluate if the HfL goals were satisfied. This demonstration project gave FDOT the opportunity to experience PCPS and to compare this innovative paving method with traditional concrete paving. The innovative method proved to be a positive experience in achieving the HfL performance goals of increasing safety, reducing congestion, and increasing quality. The experience gained on this successful project will help FDOT implement these innovations on future projects.			
17. Key Words Highways for LIFE, precast concrete pavement system		18. Distribution Statement No restriction. This document is available to the public through the Highways for LIFE website: http://www.fhwa.dot.gov/hfl/	
Security Classif.(of this report) Unclassified	19. Security Classif. (of this page) Unclassified	20. No. of Pages 37	21. Price

SI* (MODERN METRIC) CONVERSION FACTORS

APPROXIMATE CONVERSIONS TO SI UNITS

Symbol	When You Know	Multiply By	To Find	Symbol
LENGTH				
(none)	mil	25.4	micrometers	µm
in	inches	25.4	millimeters	mm
ft	feet	0.305	meters	m
yd	yards	0.914	meters	m
mi	miles	1.61	kilometers	km
AREA				
in ²	square inches	645.2	square millimeters	mm ²
ft ²	square feet	0.093	square meters	m ²
yd ²	square yards	0.836	square meters	m ²
ac	acres	0.405	hectares	ha
mi ²	square miles	2.59	square kilometers	km ²
VOLUME				
fl oz	fluid ounces	29.57	milliliters	mL
gal	gallons	3.785	liters	L
ft ³	cubic feet	0.028	cubic meters	m ³
yd ³	cubic yards	0.765	cubic meters	m ³
NOTE: volumes greater than 1000 L shall be shown in m ³				
MASS				
oz	ounces	28.35	grams	g
lb	pounds	0.454	kilograms	kg
T	short tons (2000 lb)	0.907	megagrams (or "metric ton")	Mg (or "t")
TEMPERATURE (exact degrees)				
°F	Fahrenheit	5 (F-32)/9 or (F-32)/1.8	Celsius	°C
ILLUMINATION				
fc	foot-candles	10.76	lux	lx
fl	foot-Lamberts	3.426	candela per square meter	cd/m ²
FORCE and PRESSURE or STRESS				
lbf	poundforce	4.45	Newtons	N
lbf/in ² (psi)	poundforce per square inch	6.89	kiloPascals	kPa
k/in ² (ksi)	kips per square inch	6.89	megaPascals	MPa
DENSITY				
lb/ft ³ (pcf)	pounds per cubic foot	16.02	kilograms per cubic meter	kg/m ³

APPROXIMATE CONVERSIONS FROM SI UNITS

Symbol	When You Know	Multiply By	To Find	Symbol
LENGTH				
µm	micrometers	0.039	mil	(none)
mm	millimeters	0.039	inches	in
m	meters	3.28	feet	ft
m	meters	1.09	yards	yd
km	kilometers	0.621	miles	mi
AREA				
mm ²	square millimeters	0.0016	square inches	in ²
m ²	square meters	10.764	square feet	ft ²
m ²	square meters	1.195	square yards	yd ²
ha	hectares	2.47	acres	ac
km ²	square kilometers	0.386	square miles	mi ²
VOLUME				
mL	milliliters	0.034	fluid ounces	fl oz
L	liters	0.264	gallons	gal
m ³	cubic meters	35.314	cubic feet	ft ³
m ³	cubic meters	1.307	cubic yards	yd ³
MASS				
g	grams	0.035	ounces	oz
kg	kilograms	2.202	pounds	lb
Mg (or "t")	megagrams (or "metric ton")	1.103	short tons (2000 lb)	T
TEMPERATURE				
°C	Celsius	1.8C+32	Fahrenheit	°F
ILLUMINATION				
lx	lux	0.0929	foot-candles	fc
cd/m ²	candela per square meter	0.2919	foot-Lamberts	fl
FORCE and PRESSURE or STRESS				
N	Newtons	0.225	poundforce	lbf
kPa	kiloPascals	0.145	poundforce per square inch	lbf/in ² (psi)
MPa	megaPascals	0.145	kips per square inch	k/in ² (ksi)

*SI is the symbol for the International System of Units. Appropriate rounding should be made to comply with Section 4 of ASTM E380. (Revised March 2003)

TABLE OF CONTENTS

INTRODUCTION	1
HIGHWAYS FOR LIFE DEMONSTRATION PROJECTS	1
REPORT SCOPE AND ORGANIZATION	3
PROJECT OVERVIEW AND LESSONS LEARNED	5
PROJECT OVERVIEW	5
HfL PERFORMANCE GOALS	6
ECONOMIC ANALYSIS	7
LESSONS LEARNED	7
CONCLUSIONS	7
PROJECT DETAILS	9
BACKGROUND	9
PROJECT DESCRIPTION	10
DATA ACQUISITION AND ANALYSIS	19
SAFETY	19
CONSTRUCTION CONGESTION	20
QUALITY	21
TECHNOLOGY TRANSFER	25
ECONOMIC ANALYSIS	27
CONSTRUCTION TIME	27
CONSTRUCTION COSTS	27
COST ANALYSIS	28
APPENDIX	29
ACKNOWLEDGMENTS	31

LIST OF FIGURES

Figure 1. Map. Project location (source: MapQuest).....	5
Figure 2. Map. Project limits (source: MapQuest).	10
Figure 3. Diagram. Precast concrete pavement cross section.....	11
Figure 4. Photo. Panel placement.	12
Figure 5. Diagram. Panel prestressing layout.	13
Figure 6. Diagram. Anchorage block-out detail.	13
Figure 7. Diagram. Interior panel plan view.....	14
Figure 8. Diagram. Transverse joint keyway detail.....	14
Figure 9. Photos. Transverse joint keyway and exposed post-tension duct.....	15
Figure 10. Diagram. End panel section view.....	15
Figure 11. Photo. End panel with exposed dowel bars.	16
Figure 12. Photo. Dowel pocket.	16
Figure 13. Diagram. Bolster plan and details.	17
Figure 14. Photos. OBSI dual probe system and the SRTT.....	21
Figure 15. Chart. Mean A-weighted SI frequency spectra before and after construction.	22
Figure 16. Photo. High-speed inertial profiler mounted behind the test vehicle.	23
Figure 17. Graph. Mean IRI values computed at 20-ft intervals before and after construction. ...	23
Figure 18. Photo. Showcase participants listen to presentations.	25
Figure 19. Photo. Panel placement during the showcase.....	25
Figure 20. FDOT showcase agenda.	29

LIST OF TABLES

Table 1. Historic crash rates.....	19
Table 2. Travel time data during construction.	20
Table 3. Capital cost calculation table.	27
Table 4. PCPS installation costs.	28

ABBREVIATIONS AND SYMBOLS

AADT	annual average daily traffic
ADT	average daily traffic
AASHTO	American Association of State Highway and Transportation Officials
dB(A)	A-weighted decibel
DOT	department of transportation
FDOT	Florida Department of Transportation
FHWA	Federal Highway Administration
GFRP	glass fiber reinforced polymer
HfL	Highways for LIFE
IRI	International Roughness Index
MOT	maintenance of traffic
OBSI	onboard sound intensity
OSHA	Occupational Safety and Health Administration
PCC	portland cement concrete
PCPS	Precast Concrete Pavement System
SAFETEA-LU	Safe, Accountable, Flexible, Efficient Transportation Equity Act: A Legacy for Users
SI	sound intensity
SP	Superpave
SRTT	standard reference test tire
VOC	vehicle operating cost

INTRODUCTION

HIGHWAYS FOR LIFE DEMONSTRATION PROJECTS

The Highways for LIFE (HfL) pilot program, the Federal Highway Administration (FHWA) initiative to accelerate innovation in the highway community, provides incentive funding for demonstration construction projects. Through these projects, the HfL program promotes and documents improvements in safety, construction-related congestion, and quality that can be achieved by setting performance goals and adopting innovations.

The HfL program—described in the Safe, Accountable, Flexible, Efficient Transportation Equity Act: A Legacy for Users (SAFETEA-LU)—may provide incentives to a maximum of 15 demonstration projects a year. The funding amount may total up to 20 percent of the project cost, but not more than \$5 million. Also, the Federal share for an HfL project may be up to 100 percent, thus waiving the typical State-match portion. At the State's request, a combination of funding and waived match may be applied to a project.

To be considered for HfL funding, a project must involve constructing, reconstructing, or rehabilitating a route or connection on an eligible Federal-aid highway. It must use innovative technologies, manufacturing processes, financing, or contracting methods that improve safety, reduce construction congestion, and enhance quality and user satisfaction. To provide a target for each of these areas, HfL has established demonstration project performance goals.

The performance goals emphasize the needs of highway users and reinforce the importance of addressing safety, congestion, user satisfaction, and quality in every project. The goals define the desired result while encouraging innovative solutions, raising the bar in highway transportation service and safety. User-based performance goals also serve as a new business model for how highway agencies can manage the project delivery process.

HfL project promotion involves showing the highway community and the public how demonstration projects are designed and built and how they perform. Broadly promoting successes encourages more widespread application of performance goals and innovations in the future.

Project Solicitation, Evaluation, and Selection

FHWA issued open solicitations for HfL project applications in fiscal years 2006 through 2013. State highway agencies submitted applications through FHWA Divisions. The HfL team reviewed each application for completeness and clarity, then contacted applicants to discuss technical issues and obtain commitments on project issues. Documentation of these questions and comments was sent to applicants, who responded in writing.

The project selection panel consisted of representatives of the FHWA offices of Infrastructure, Safety, and Operations; the Resource Center Construction and Project Management team; the Division offices; and the HfL team. After evaluating and rating the applications and

supplemental information, panel members convened to reach a consensus on the projects to recommend for approval. The panel gave priority to projects that accomplish the following:

- Address the HfL performance goals for safety, construction congestion, quality, and user satisfaction.
- Use innovative technologies, manufacturing processes, financing, contracting practices, and performance measures that demonstrate substantial improvements in safety, congestion, quality, and cost-effectiveness. An innovation must be one the applicant State has never or rarely used, even if it is standard practice in other States.
- Include innovations that will change administration of the State's highway program to more quickly build long-lasting, high-quality, cost-effective projects that improve safety and reduce congestion.
- Will be ready for construction within 1 year of approval of the project application. For the HfL program, FHWA considers a project ready for construction when the FHWA Division authorizes it.
- Demonstrate the willingness of the applicant department of transportation (DOT) to participate in technology transfer and information dissemination activities associated with the project.

HfL Project Performance Goals

The HfL performance goals focus on the expressed needs and wants of highway users. They are set at a level that represents the best of what the highway community can do, not just the average of what has been done. States are encouraged to use all applicable goals on a project:

- **Safety**
 - Work zone safety during construction—Work zone crash rate equal to or less than the preconstruction rate at the project location.
 - Worker safety during construction—Incident rate for worker injuries of less than 4.0, based on incidents reported on Occupational Safety and Health Administration (OSHA) Form 300.
 - Facility safety after construction—Twenty percent reduction in fatalities and injuries in 3-year average crash rates, using preconstruction rates as the baseline.
- **Construction Congestion**
 - Faster construction—Fifty percent reduction in the time highway users are impacted, compared to traditional methods.
 - Trip time during construction—Less than 10 percent increase in trip time compared to the average preconstruction speed, using 100 percent sampling.
 - Queue length during construction—A moving queue length of less than 0.5 miles in a rural area or less than 1.5 miles in an urban area (in both cases at a travel speed 20 percent less than the posted speed).
- **Quality**
 - Smoothness—International Roughness Index (IRI) measurement of less than 48 in/mi.

- Noise—Tire-pavement noise measurement of less than 96.0 A-weighted decibels (dB(A)), using the onboard sound intensity (OBSI) test method.
- **User Satisfaction**—An assessment of how satisfied users are with the new facility compared to its previous condition and with the approach used to minimize disruption during construction. The goal is a measurement of 4 or more on a 7-point Likert scale.

REPORT SCOPE AND ORGANIZATION

This report documents the Florida Department of Transportation (FDOT) HfL demonstration project featuring a precast concrete pavement system on US 92 west of Daytona Beach. The report presents project details relevant to the HfL program, including construction highlights, HfL performance metrics measurement, and economic analysis. Technology transfer activities that took place during the project and lessons learned are also discussed.

PROJECT OVERVIEW AND LESSONS LEARNED

PROJECT OVERVIEW

The project was located on US 92 (State Road 600), a four-lane divided highway, between DeLand and Daytona Beach, Florida. The scope of the project was to rehabilitate the existing concrete pavement in the westbound lanes (built in the 1940s) and to use a precast concrete pavement system (PCPS) as an unbonded overlay at an area known to have soft organic soil and a high degree of pavement distress. The eastbound lanes were built in the 1970s and are at higher elevation. While PCPS is not new to many States, this project is the first of its kind in central Florida. The project location is shown in figure 1.

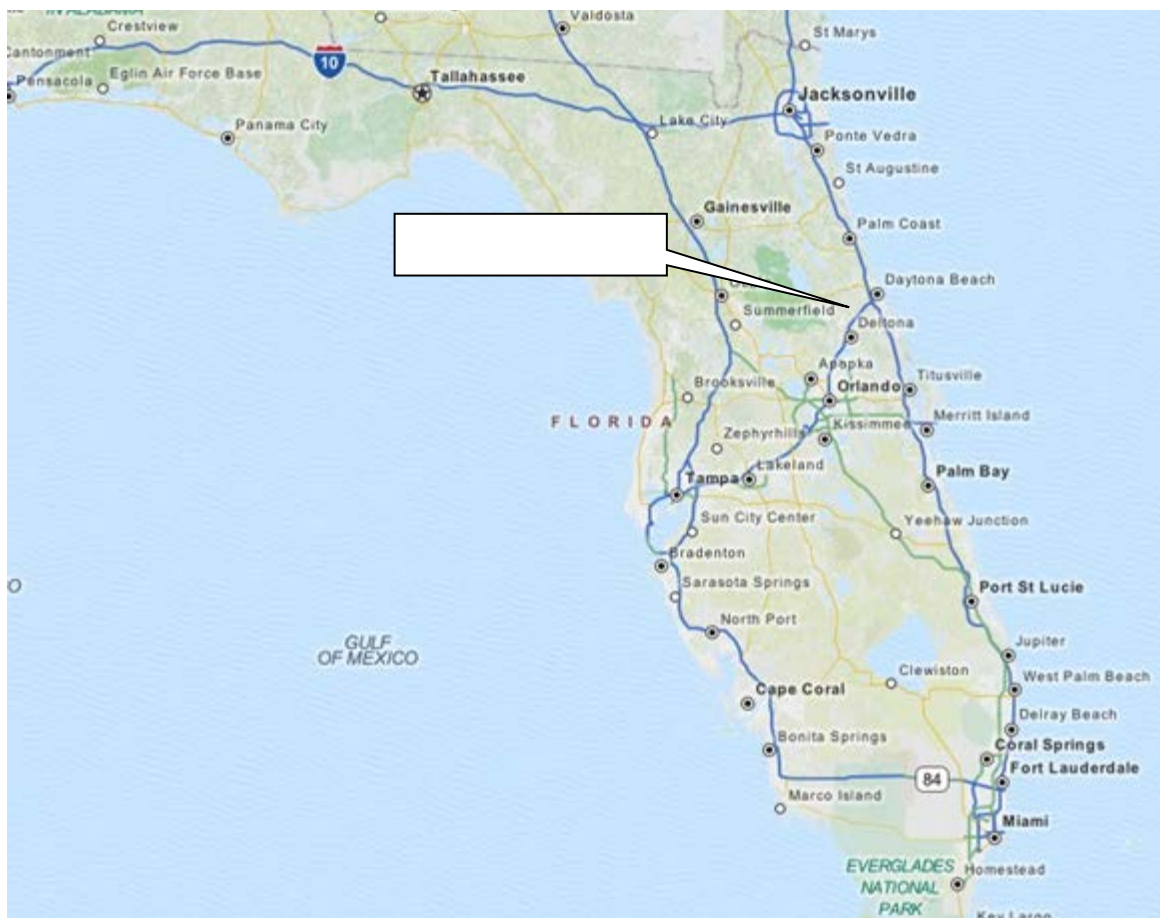

Figure 1. Map. Project location (source: MapQuest).

The construction contract included concrete pavement rehabilitation consisting of crack/joint sealing, partial and full-depth patching, unbonded concrete overlay with a 793-ft PCPS test section, and 9,152 ft of traditional concrete overlay paving plus intersection modifications at a major crossroad. The focus of this report is the PCPS test section.

The highway had not had a major rehabilitation, only localized repairs. Moreover, the westbound lanes had experienced overtopping in the past from heavy rains. The concrete overlay portion raised the grade of the westbound lanes, which will help to prevent flooding in the future.

HfL PERFORMANCE GOALS

Safety, construction congestion, quality, and user satisfaction data were collected before, during, and after construction to demonstrate that innovations can be an integral part of a project while simultaneously meeting the HfL performance goals in these areas.

- **Safety**
 - Work zone safety during construction— No motorist incidents occurred during the construction period, meeting the HfL goal of achieving a work zone crash rate equal to or less than the preconstruction rate.
 - Worker safety during construction—No workers were injured on the project, so the contractor achieved a score of 0.0 on the OSHA Form 300, meeting the HfL goal of less than 4.0.
 - Facility safety after construction—The HfL goal of 20 percent reduction in fatalities and injuries in 3-year crash rates compared to preconstruction rates is yet to be determined.

- **Construction Congestion**
 - Faster construction—The PCPS section was constructed in 14 days. The PCPS portion of the roadway section was relatively short (793 feet of PCPS installation in comparison with 8.2 miles of concrete pavement rehabilitation), so this goal was not evaluated. However, on a larger scale, the use of PCPS technology has the potential to reduce the traffic impact time by 50 percent when compared with traditional construction methods.
 - Trip time—Travel time measurements collected during construction indicated a 12 percent increase in trip time compared to the average preconstruction conditions, thus slightly exceeding the HfL goal of no more than 10 percent.
 - Queue length during construction—The project met the HfL goal of less than a 0.5-mile queue length in a rural area, as there were no traffic backups along the detour route.

- **Quality**
 - Smoothness — The IRI value of the existing deteriorated concrete pavement was 145 in/mi. The IRI value of the PCPS test section was 55 in/mi representing a significant improvement in ride quality compared to the preconstruction scenario; however, the project did not meet the HfL goal of smoothness less than 48 in/mi.
 - Noise—The sound intensity data showed a noticeable 5.9 dB(A) decrease in noise. The sound intensity of the existing pavement was 105 dB(A), and the new pavement was 99.1 dB(A), which exceeded the HfL requirement of 96.0 dB(A) or less.

ECONOMIC ANALYSIS

A cost analysis was not conducted for this project because the cost of the PCPS portion was only 2.7 percent of the total construction costs for the project. Furthermore, the as-built PCPS section was an experimental section and was relatively short (0.15 miles) compared to typical paving projects. For these reasons, the results of a cost analysis might not reflect the magnitude of PCPS benefits (i.e. life cycle cost savings and productivity gains) observed in typical paving projects. However, the unit price of PCPS on this project was lower than those on other HfL PCPS projects.

LESSONS LEARNED

Following were the lessons learnt on this demonstration project:

- The experience gained on this successful project will help FDOT implement these innovations more routinely on future projects.
- Under-slab grouting may not be necessary.

CONCLUSIONS

This demonstration project gave FDOT the opportunity to experience PCPS and to compare this innovative paving method with traditional concrete paving. The innovative method proved to be a positive experience in achieving the HfL performance goals of increasing safety, reducing congestion, and increasing quality.

PROJECT DETAILS

BACKGROUND

One reason State departments of transportation (DOTs) may select asphalt pavements over concrete pavements is the ability to open an area for traffic in hours after placement. Concrete pavement can take up to 6 to 8 hours even if accelerated mixes are used. Precast concrete pavement has the promise of reducing this time.

Precast concrete pavement had not been utilized in central Florida prior to this demonstration project. Other States are familiar with PCPS, and this demonstration project introduced precast concrete pavement methods of construction to the central Florida market. This project provided FDOT with the opportunity to gain firsthand knowledge in the construction techniques, as well as to develop plans, specifications, and guidelines for precast concrete pavement construction. Major areas of development include precast panel design, manufacturing, assembling criteria, post placement grouting, post-tensioning systems, and post-construction pavement grinding for smoothness.

The entire length of the rehabilitation project was 8.2 miles from milepost 7.2 to milepost 15.4.

The project was awarded to Superior Construction Company of Indiana LLC for \$13.6 million including the PCPS test section. Precasting was carried out at the Dura-Stress, Inc. facility in Leesburg, Florida, approximately 40 miles from the site. Construction of the PCPS section began on January 2, 2012, and was completed on January 13, 2012, for a total of 14 working days.

In 2009 the highway had an average daily traffic (ADT) of 13,000 vehicles per day with 5.49 percent trucks. The traffic level is expected to increase to 21,200 vehicles per day in 2031.



Figure 2. Map. Project limits (source: MapQuest).

PROJECT DESCRIPTION

The existing concrete pavement was built with a trapezoidal cross-section having a 9-inch thickened edge tapering to a 7-inch center. The compressive strength of the concrete was tested at $8,500 \text{ lb/in}^2$ and had 1.5-inch nominal maximum aggregate size. Typical slabs in each lane were 20 ft long by 11 ft wide for a total pavement width of 22 ft, with an asphalt shoulder next to the outer lane. Joints were non-skewed and doweled. Excavations revealed a layer of stabilized subgrade under the existing pavement.

A key design consideration for FDOT was to leave the existing pavement in place. This would avoid disturbing the subgrade, provide a stable working platform, simplify construction, and leave the finished grade of the new pavement higher than the existing pavement to lessen the possibility of overtopping from heavy rains, as has been experienced in the past.

Traffic control was set up with the rehabilitation work in three stages. The first setup was on the west portion of the project to allow work to be done on the patching and crack sealing. Then traffic control was in effect for the middle portion of the highway that included the PCC overlay and PCPS test area. Finally, traffic control was moved to the east portion of the highway to complete the PCC overlay. The maintenance of traffic (MOT) plan for each stage had both westbound lanes of traffic merge into one lane and maneuver through existing median crossovers to the inside eastbound lane as the eastbound lanes were configured for head-to-head traffic with one lane in each direction. Access to cross roads was maintained throughout the project.

To begin the PCPS paving process, an asphalt interlayer was placed over the original pavement to change the slope of the existing pavement from a crown to a continuous 2 percent cross slope that drains both lanes to the outside shoulder and to provide a smooth base for the precast panels. Under-slab grout was not used to bed the precast panels, making it important to achieve a flat asphalt layer to fully support the panels as much as possible. The asphalt was an FDOT standard Superpave (SP) 9.5-mm mix placed at a minimum of 2 inches thick, transitioning to 6 inches or more on the outer edge of the inside lane. The asphalt interlayer layer is represented in figure 3 as double cross-hatching under the pavement panels (post-tensioned concrete slabs).

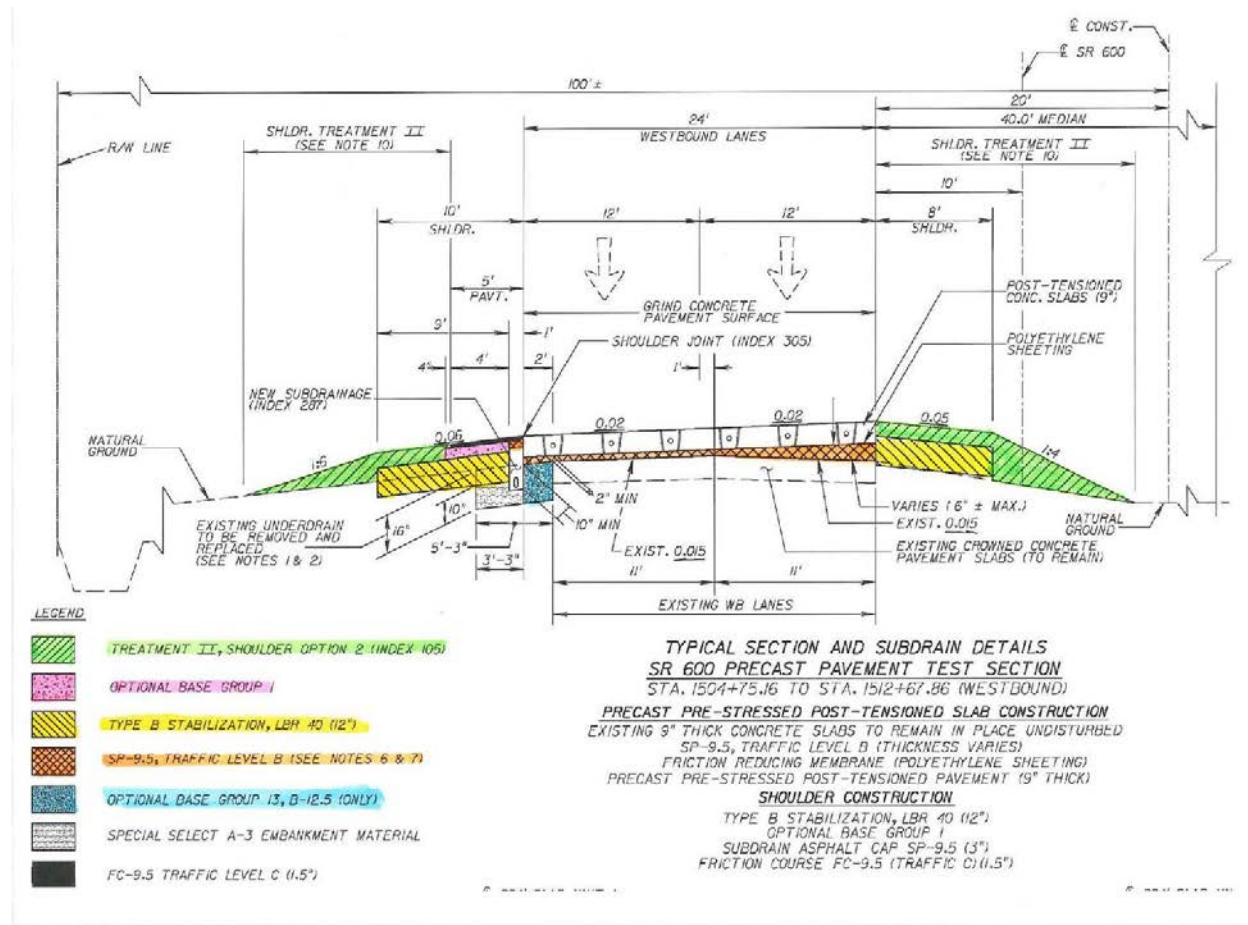

Figure 3. Diagram. Precast concrete pavement cross section.

The project plans called for the asphalt interlayer to meet or exceed all surface finish requirements of a “final type SP structural layer” as required by FDOT’s Standard Specifications for Road and Bridge Construction. Under this specification, immediate corrections are triggered if the traveling lane’s actual cross slope deviates ± 0.2 percent from design and if surface deficiencies develop in excess of 3/16 inch.

The 793-ft-long PCPS test section consisted of three units. Each unit was 264 ft long with 22 panels per unit post-tensioned together. Panels were 9 inches thick, 12 ft long, and 24 ft wide and weighed about 16 tons each. A 2-ft-wide extension of the base along the outside edge was made to accommodate the width of the new pavement since the existing pavement was only 22 ft wide.

Base drainage was planned through a new subdrain system located along the outside edge of the base.

Before the panels were set in place, a single layer of polyethylene sheeting was spread over the asphalt to reduce friction and allow the panels to contract during post-tensioning. The polyethylene sheeting is visible in figure 4 extending out in front of a panel as workers prepare to place another panel. This figure shows the asphalt base and sheeting under the panel. A rubber-tire crane used to lift the panels from a flatbed tractor trailer and place the panels is shown in the background.



Figure 4. Photo. Panel placement.

Design traffic loading for the precast pavement was 2.8 million 20-kip equivalent single axle loads over a 30-year design life. The concrete material properties used for design were 700 lb/in² tensile strength, 3,800 k/in² modulus of elasticity, and 5.5 k/in² minimum 28-day compressive strength.

The panels were prestressed in the transverse direction during fabrication and after placement, post-tensioned as a 22-panel unit in the longitudinal direction. Anchorage block-outs for the longitudinal post-tension tendons were cast into the end panels of each unit as shown in figure 5. Figure 6 details the block-out. For design, the net prestress force was 31,000 lbf and the net longitudinal post-tensioning jacking force was 43,400 lbf. There were four 0.5-inch-diameter prestress strands per panel and six 0.6-inch-diameter post-tensioning strands per panel unit. After post-tensioning the ducts were filled with 8.0 k/in² compressive strength grout according to standard FDOT specifications.

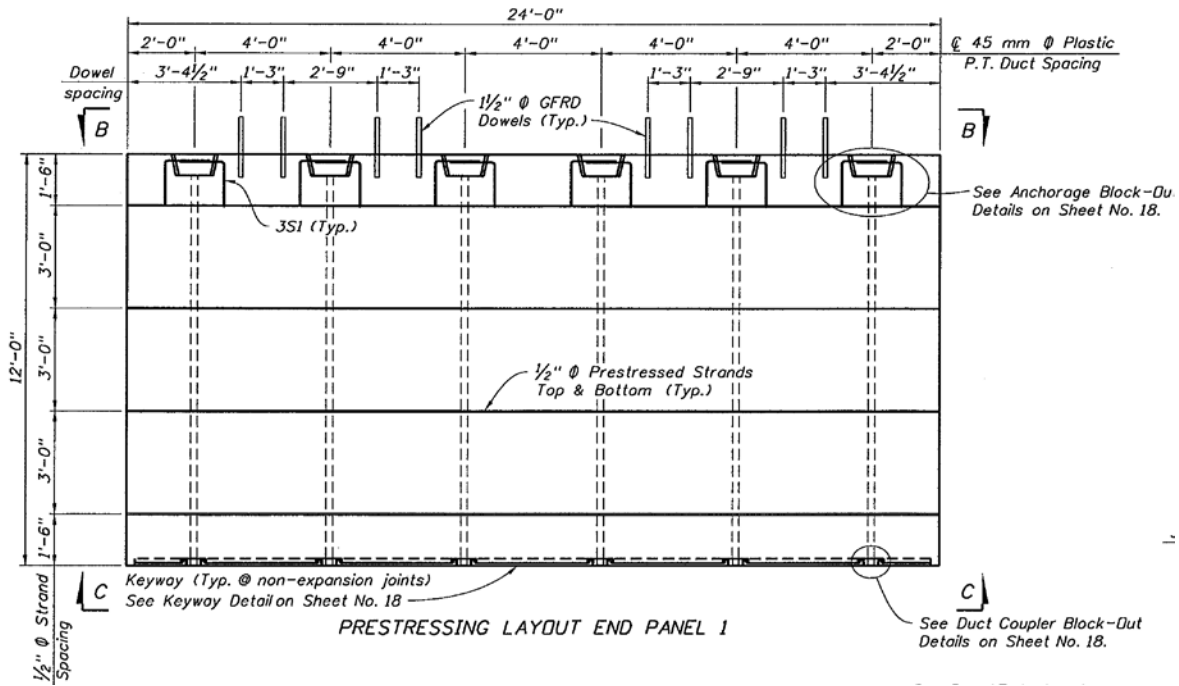

Figure 5. Diagram. Panel prestressing layout.

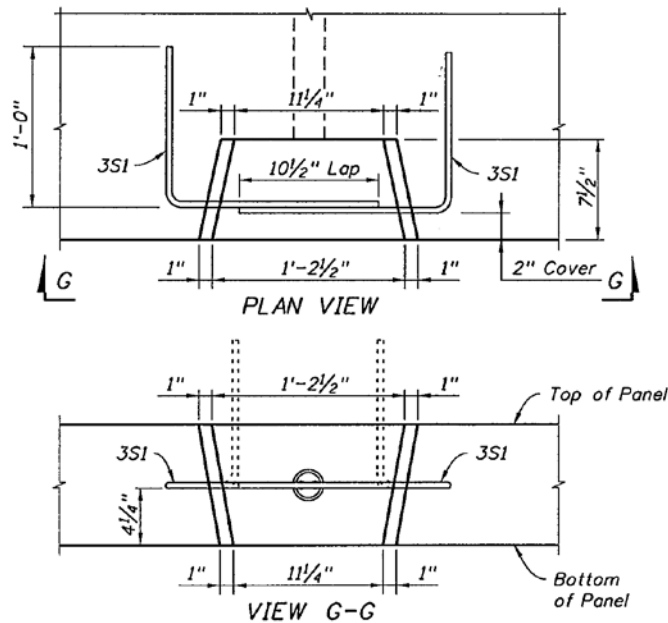

Figure 6. Diagram. Anchorage block-out detail.

The transverse edges between the interior panels of each unit were cast to form keyways when fitted together, allowing workers just enough space to splice the post-tensioning ducts with heat shrink wrap. To ensure the plastic ducts were kept straight and aligned properly, wood supports were inserted in the ducts during casting. This allowed the strands to be pulled through the ducts with minimal effort.

Afterwards, the keyways were filled with non-shrink grout flush with the pavement surface. Figure 7 shows the plan view of an interior, and figure 8 shows the details of the transverse joint keyway. Figure 9 shows a key with post-tension duct joined with yellow colored shrink wrap.

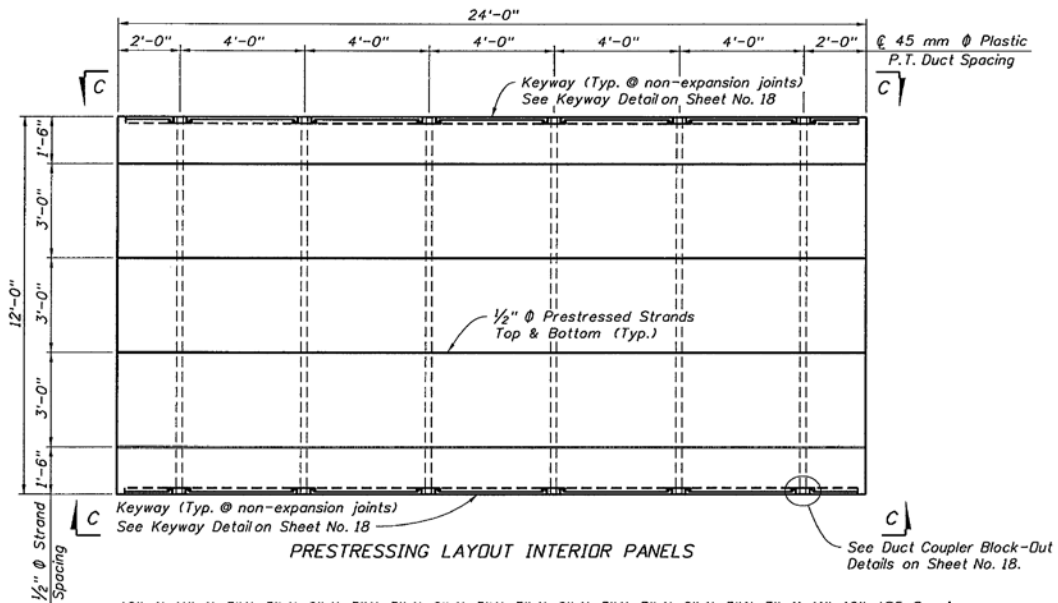

Figure 7. Diagram. Interior panel plan view.

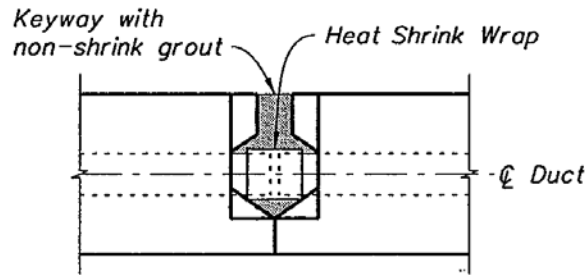
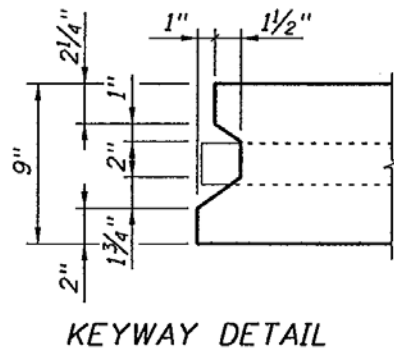

Figure 8. Diagram. Transverse joint keyway detail.

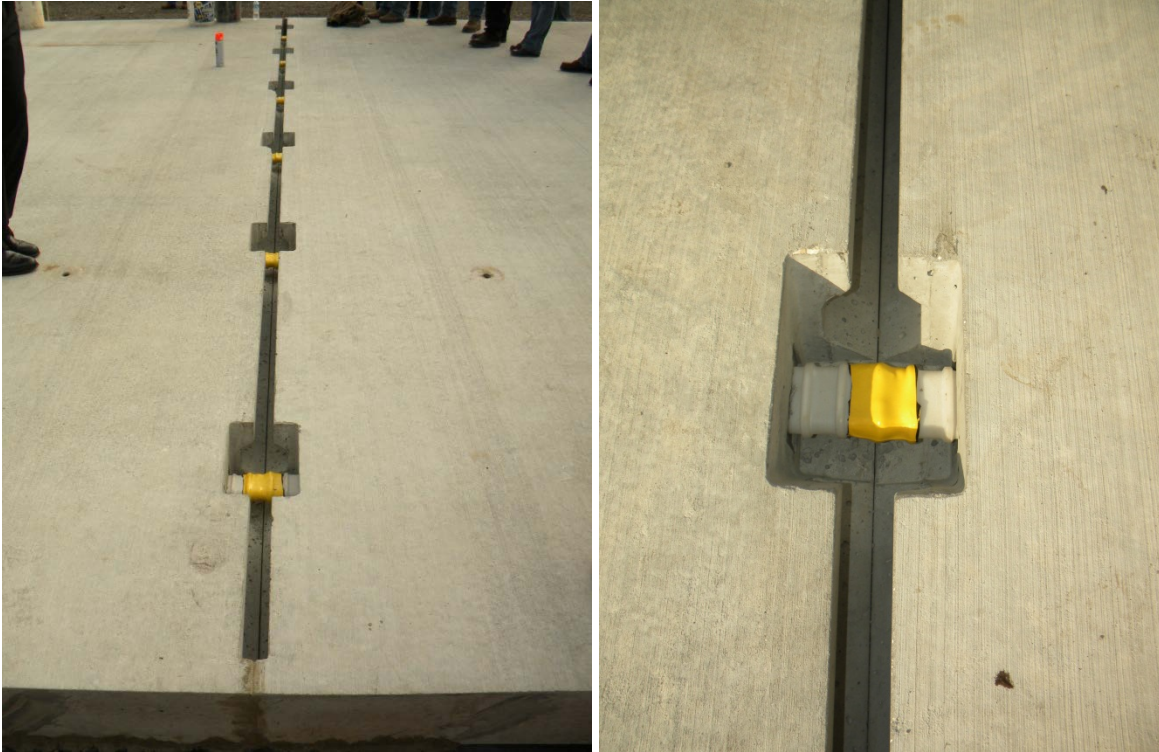

Figure 9. Photos. Transverse joint keyway and exposed post-tension duct.

Expansion joints were included between the three PCPS units and where the test section joins the cast-in-place concrete pavement on each end of the test section. Here, 1.5-inch-diameter, 20-inch-long glass fiber reinforced polymer (GFRP) dowel rods were grouted into dowel pockets cast in the end panels. This detail promotes traffic load transfer from one PCPS unit to another or from the PCPS end unit to the cast-in-place panel. The expansion joint openings were designed to account for temperature, creep, and shrinkage movement. The finished expansion joints in the PCPS test section were filled with silicone sealant on top of foam backer rod to keep the joints free of debris. Figure 10 shows the section view of an end panel from the plan drawings. Figure 11 shows an actual end panel with dowels—note the post-tension anchorage block-outs between the sets of dowels have been filled in with grout. The dowels between precast units were accommodated by precast pockets as shown in figure 12.

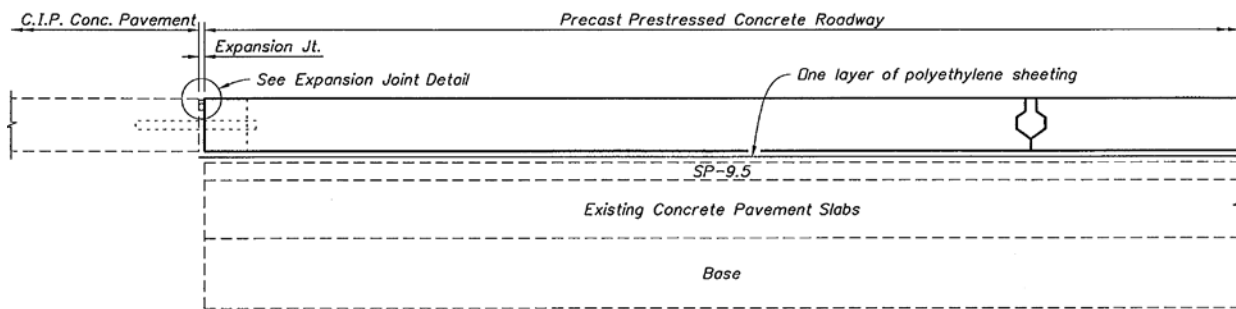

Figure 10. Diagram. End panel section view.



Figure 11. Photo. End panel with exposed dowel bars.



Figure 12. Photo. Dowel pocket.

The new pavement was diamond ground to produce a smooth surface profile. After grinding, the joints were filled with silicon sealant.

Bolsters were installed in the outside shoulder of the PCPS section (downslope side) for lateral support. Each PCPS unit has two reinforced concrete bolsters measuring 3 yd³, each installed at 20 ft to each side of the middle of each unit on the outside (downslope side) of the precast pavement for lateral support. The bolster plan and details are shown in figure 13.

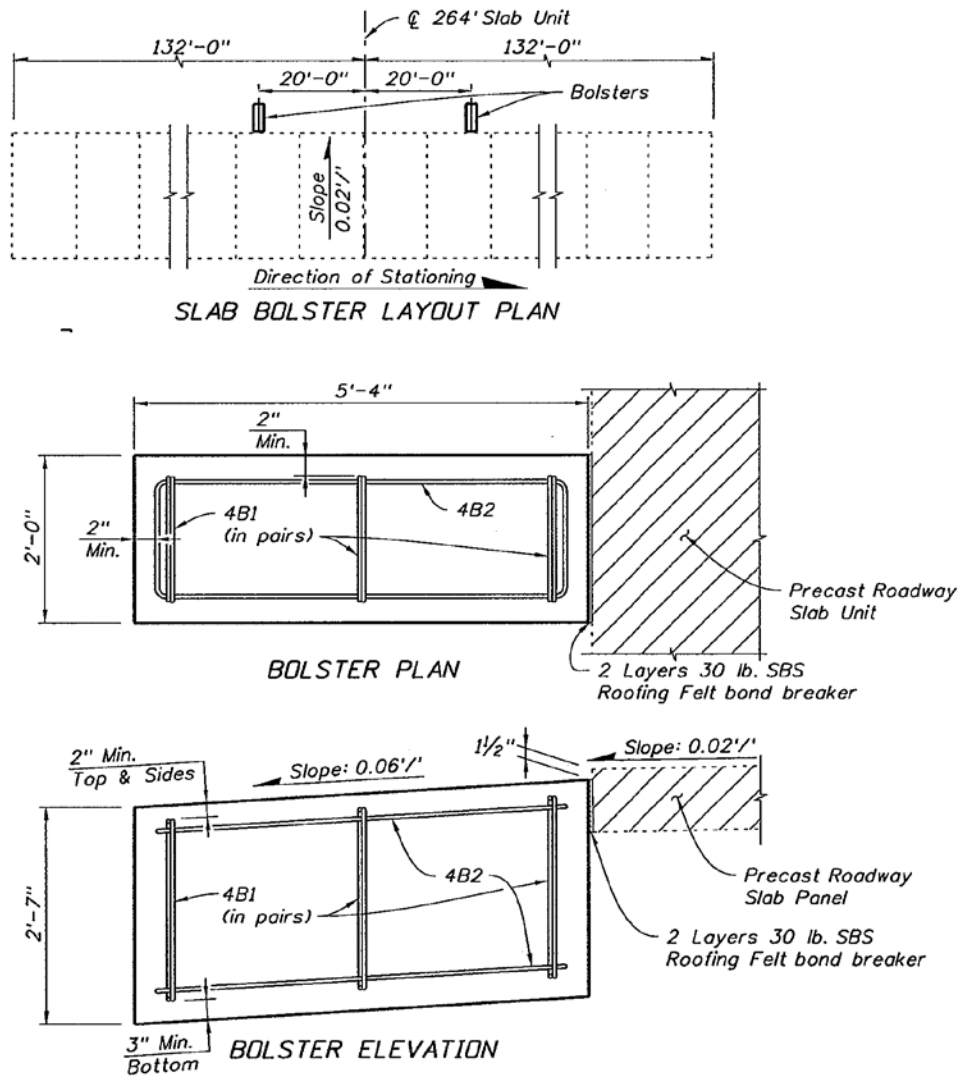

Figure 13. Diagram. Bolster plan and details.

The precast concrete pavement construction sequence is summarized as follows:

- Widen the existing pavement by 2 ft.
- Place asphalt interlayer and cover with polyethylene sheeting.
- Place panels units beginning at one end, followed by interior panels, and then the other end panel.
- Splice post-tensioning ducts with heat shrink wrap.
- Grout keyways with non-shrink grout.
- Thread longitudinal post-tensioning tendons, stress tendons, and grout ducts.
- Place GFRP dowel rods.
- Grout dowel pockets and post-tensioning anchorages.
- Grind the pavement surface and place silicone sealant in the expansion joints.
- Cast support bolsters on the low side of each precast unit.

DATA ACQUISITION AND ANALYSIS

Data on safety, traffic flow, quality, and user satisfaction before, during, and after construction were collected to determine if this project met the HfL performance goals. The primary objective of acquiring these types of data was to quantify project performance and provide an objective basis from which to determine the feasibility of the project innovations and to demonstrate that the innovations can be used to do the following:

- Achieve a safer work environment for the traveling public and workers.
- Reduce construction time and minimize traffic interruptions.
- Produce a high-quality project and gain user satisfaction.

This section discusses how well the FDOT project met the HfL performance goals related to these areas.

SAFETY

The project included the HfL performance goal of achieving a work zone crash rate equal to or less than the existing conditions. Table 1 illustrates the crash rates per million vehicle miles traveled for this section of US 92 between 2003 and 2005 along with the average statewide crash rate for similar types of highways (four- to five-lane, two-way roadways divided with a raised median). The average crash rate is below the State average. During this project, no crashes occurred, satisfying the HfL goal. This can be attributed to the FDOT work zone standards, as no special traffic control was necessary for this project.

Table 1. Historic crash rates.

	2003	2004	2005	Average
Project Crash Rate	0.593	0.848	0.460	0.634
Statewide Ave	0.703	0.665	0.591	0.653

The project included the performance goal of achieving an incident rate for worker injuries less than 4.0 based on the OSHA 300 rate. No workers were injured on the project, so the contractor achieved a score of 0.0 on the OSHA Form 300, meeting the HfL goal of less than 4.0.

No motorist incidents occurred during the construction period, meeting the HfL goal of achieving a work zone crash rate equal to or less than the preconstruction rate.

The 3-year average preconstruction crash rate for combined fatalities and injuries was zero crashes per hundred million vehicle miles traveled. Due to the low crash rate at the site, the goal of a 20 percent reduction was not directly applicable. Moreover, the project did not increase the crash rate.

CONSTRUCTION CONGESTION

Faster construction

The PCPS section was constructed in 14 days. The PCPS portion of the roadway section was relatively short (793 feet of PCPS installation in comparison with 8.2 miles of concrete pavement rehabilitation), so this goal was not evaluated. However, on a larger scale, the use of PCPS technology has the potential to reduce the traffic impact time by 50 percent when compared with traditional construction methods.

Travel Time

Data were collected utilizing the floating vehicle methodology in an effort to match the driving speeds of other vehicles along US 92 between Kepler Drive on the west limit of construction to LGPA Boulevard on the east limit of construction. This 11.57-mile section of highway was evaluated for this travel time study.

Researchers collected data during construction when eastbound traffic was switched to one westbound lane for about the east third of the highway section. On these visits, researchers collected data on weekdays during daylight hours (7:00 am to 6:00 pm) when traffic demand was relatively high and the work zone traffic crossover would have the greatest impact on travel time. In general, the traffic flow was light and flowed freely without backups or congestion at or above the posted speed limit.

Table 2 presents the average travel time data collected between Kepler Drive and LGPA Boulevard on September 1, 2011. The average travel time was 720 seconds during construction with an average travel speed of 58 miles per hour (mph). The posted speed limits were 55 and 65 mph in work zone and non-work zone areas, respectively.

Table 2. Travel time data during construction.

Cross Road	Cumulative Distance (mi)	Average Cumulative Travel Time (seconds)
Eastbound		
Kepler Dr.	0.00	0
Work Zone Limit	4.80	313
Indian Rd.	9.17	589
LGPA Blvd	11.57	721
Westbound		
LGPA Blvd.	0.00	0
Indian Rd.	2.40	127
Work Zone Limit	6.77	372
Kepler Dr.	11.57	719
Combined Average Cumulative Travel Time		720

The preconstruction trip time was estimated based on the posted speed limit of 65 mph. In comparison with estimated trip time prior to construction, the presence of work zone resulted only a 78-second (or 12 percent) increase in trip time, and thus, slightly exceeding the HfL goal of less than 10 percent increase in trip time compared to average preconstruction speed.

Queue length during construction

As there were no traffic backups along the detour route, the project met the HfL goal of less than a 0.5-mile queue length in a rural area.

QUALITY

Pavement Test Site

Sound intensity and smoothness test data were collected from both eastbound and westbound directions of US 6 across the bridge before construction. Comparing these data to the test results after construction provides a measure of the quality of the finished bridge.

Sound Intensity Testing

Presently, FDOT does not use the onboard sound intensity (OBSI) test method on any projects. However, this method was used to collect tire-pavement sound intensity (SI) measurements from the existing and newly constructed bridges for comparison.

SI measurements were made using the current accepted OBSI technique described in American Association of State Highway and Transportation Officials (AASHTO) TP 76-10, which includes dual vertical sound intensity probes and an ASTM-recommended standard reference test tire (SRTT). SI data collection was done prior to construction and on the new bridge surfaces shortly after opening to traffic. The SI measurements were recorded and analyzed using an onboard computer and data collection system. A minimum of three runs were made in the right wheelpath of the project. The two microphone probes simultaneously captured noise data from the leading and trailing tire/pavement contact areas. Figure 14 shows the dual probe instrumentation and the tread pattern of the SRTT.



Figure 14. Photos. OBSI dual probe system and the SRTT.

The average of the front and rear OBSI values from both lane directions was computed to produce the global SI level. Raw noise data were normalized for the ambient air temperature and barometric pressure at the time of testing. The resulting mean SI level was A-weighted to produce the SI frequency spectra in one-third octave bands, as shown in figure 15.

SI levels were calculated using logarithmic addition of the one-third octave band frequencies across the spectra. The SI level before reconstruction was 105.0 dB(A). The SI level after reconstruction was 99.1 dB(A). While not meeting the HfL goal of less than 96.0 dB(A), the new pavement is an improvement.

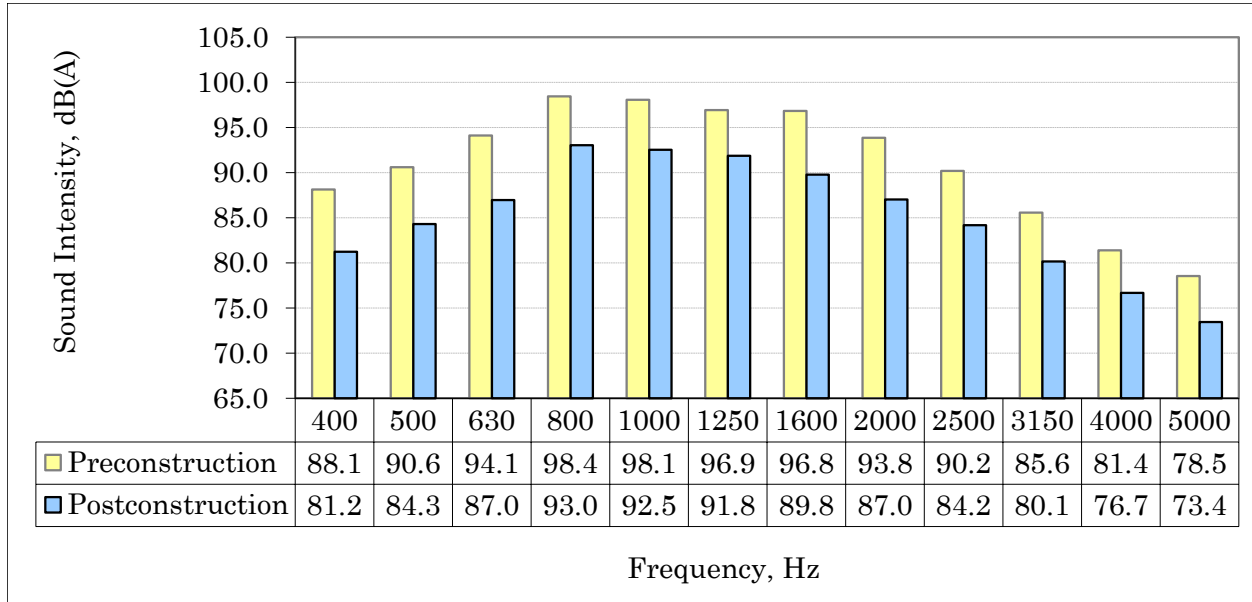

Figure 15. Chart. Mean A-weighted SI frequency spectra before and after construction.

Smoothness Measurement

Smoothness data collection was done in conjunction with the SI runs utilizing a high-speed inertial profiler integrated into the noise test vehicle. The profile data collected with this equipment provide IRI values, with lower values indicating a higher quality ride. Figure 16 is an image of the test vehicle showing the profiler positioned in-line with the right rear wheel. Figure 17 graphically presents the IRI values at 20-ft intervals for the existing bridge surfaces.

The IRI value of the existing deteriorated concrete pavement was 145 in/mi. The IRI value of the PCPS test section was 55 in/mi representing a significant improvement in ride quality compared to the preconstruction scenario; however, the project did not meet the HfL goal of smoothness less than 48 in/mi.



Figure 16. Photo. High-speed inertial profiler mounted behind the test vehicle.

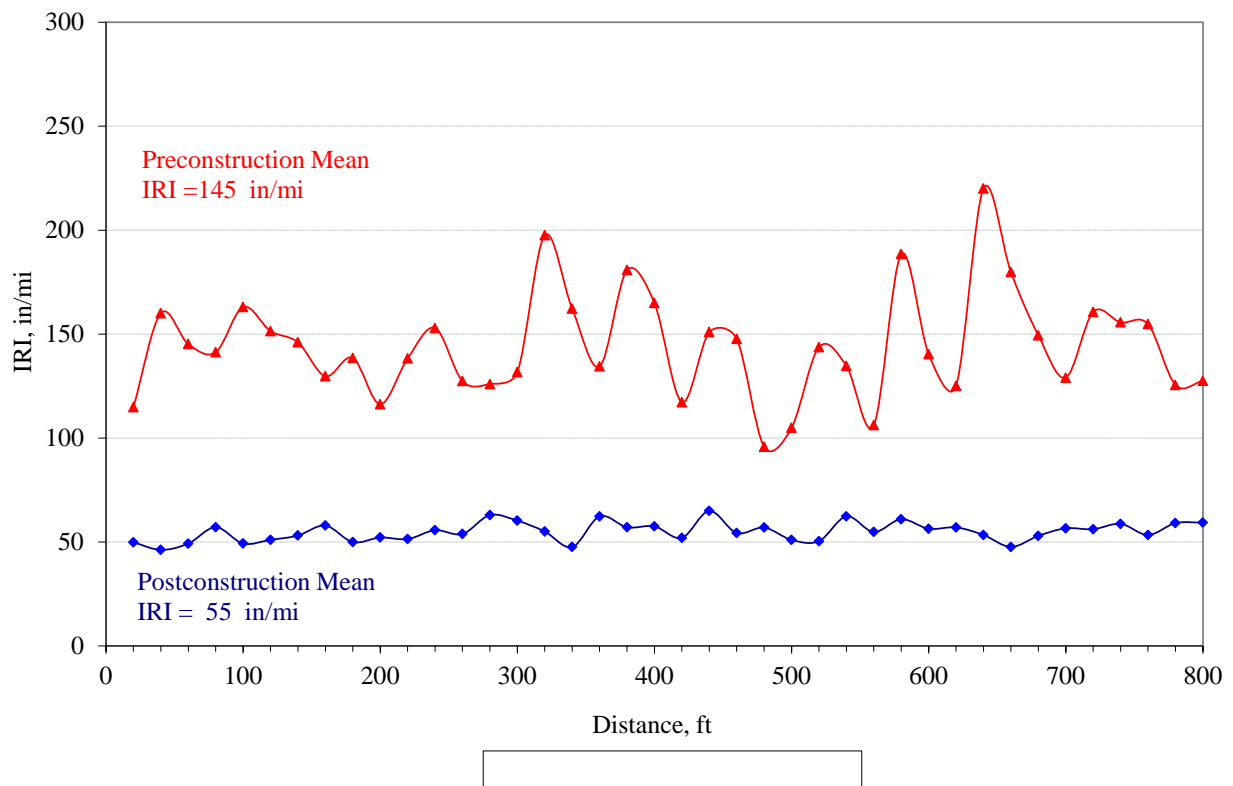

Figure 17. Graph. Mean IRI values computed at 20-ft intervals before and after construction.

TECHNOLOGY TRANSFER

To promote the PCPS technology, FDOT and FHWA sponsored a 1-day showcase. The showcase took place on January 10, 2012, at the DeLand FDOT Kepler Road Complex. The showcase was organized into a half day of technical sessions on the technologies and the project, followed by a visit to the active construction site. Figure 18 shows participants listening to a technical presentation. Figure 19 was taken during the field trip in which attendees watched crews place precast panels.



Figure 18. Photo. Showcase participants listen to presentations.



Figure 19. Photo. Panel placement during the showcase.

The showcase attracted local DOT personnel and contractors, as well as engineers from out of State. The appendix contains the workshop agenda. Alan E. Hyman, P.E., Director of Transportation Operations – FDOT District 5, provided the showcase introduction and opening remarks. David Hawk, P.E., Chief Operating Officer – FHWA Florida Division, gave an overview of the HfL program. The FHWA’s concrete pavement engineers Suneel Vanikar, P.E., and Sam Tyson, P.E., discussed the national perspective on PCPS.

Presentation of the project began with an overview from Mario Bizzio, P.E., Technical Support & In-House Design Engineer – FDOT District 5, and Sam Fallaha, P.E., Assistant State Structures Design Engineer – FDOT. Mr Bizzio presented the site conditions and design concepts, and Mr. Fallaha presented key design considerations of the precast panels.

Jeremy Wolcott, P.E., Materials Operations Engineer – FDOT District 5, presented detailed information on the panel fabrication process including pre-tensioning procedures. Jeremy Andrews, P.E., Project Manager – Superior Construction Company, gave the contractor’s perspective of the project. Mr. Andrews explained the panel installation, including the post-tensioning process in which workers use standard hydraulic rams to tension the cables and pumps to fill the post-tension ducts with grout. The final presentation was made by Chetana Rao, Ph.D., Principal Research Engineer of Applied Research Associates, Inc. Dr. Rao reviewed similar HfL PCPS projects and shared some of the lessons learned from those projects.

After a lunch break the attendees visited the job site to watch the contractor place panels for the second PCPS unit. The first PCPS unit, already in place, gave the attendees a chance to examine the pavement in a nearly finished state.

ECONOMIC ANALYSIS

A key aspect of HfL demonstration projects is quantifying, as much as possible, the value of the innovations deployed. This involves comparing the benefits and costs associated with the innovative construction approach adopted on an HfL project with those from a more traditional construction approach on a project of similar size and scope. The latter type of project is referred to as a baseline case and is an important component of the economic analysis.

For this economic analysis, FDOT supplied the cost figures for the as-built project. Traditional PCC overlay construction was part of this project and serves as the baseline. Both the PCPS and conventional PCC slip form overlay paving costs were derived from the as-built cost figures.

CONSTRUCTION TIME

The PCPS section was constructed in 14 days. The original contract time of this project was 680 days. Because the PCPS portion of the roadway section was relatively short (793 feet of PCPS installation in comparison with 8.2 miles of concrete pavement rehabilitation), this goal was not evaluated. However, on a larger scale, the use of PCPS technology has the potential to reduce the traffic impact time by 50 percent when compared with traditional construction methods.

CONSTRUCTION COSTS

The total cost of the project was \$13,651,579. In addition to the 793 ft of PCPS installation in the westbound lanes, there were other improvements under this contract that included placement of 9,152 feet of PCC overlay in the westbound lanes, concrete pavement rehabilitation and paved shoulder milling and resurfacing, pavement shoulders for PCPS and PCC overlay sections, and intersection modifications at West Parkway. Table 3 presents a breakdown of various cost categories.

Table 3. Capital cost calculation table.

Cost Category	Cost
PCPS, including edge drain	\$530,580
Plain concrete pavement overlay (9.5-in.) (FDOT Bid Item 350)	\$958,485
Maintenance of traffic	\$2,346,728
Patching & joint rehabilitation	\$2,588,414
Grinding	\$653,522
Other items	\$6,573,850
Total cost	\$13,651,579

Table 4 presents a breakdown of project costs associated with PCPS installation. These costs include the installation of 2,114 yd² of PCPS slabs (at \$175/yd²), as well as edge drain, draincrete, and outlet pipe for \$369,950, \$149,190 and \$11,440, respectively. The PCC overlay costs were \$958,485 for 24,420 yd² at a unit price of \$39.25/yd².

Table 4. PCPS installation costs.

Bid Item	Cost
Prestressed pavement at \$175/yd ²	\$369,950
Edge drain standard draincrete at \$15/yd ²	\$149,190
Edge drain 4-in.outlet pipe	\$11,440
Total PCPS related installation costs	\$530,580

The PCPS unit price on this project was \$175/yd², which is considered lower than the unit price on other HfL PCPS projects. The proprietary Super Slab® product was priced at \$418/m² (or \$338.58/yd²) on the California I-15 Devore HfL project¹ and \$350/yd² on the Virginia I-66 HfL project.²

The standard 9-inch PCC was priced at \$39.20/yd², which was comparable with the 2011 statewide average price of \$40.20/yd².³

COST ANALYSIS

Detailed analyses to evaluate the cost-effectiveness of using PCPS—including cost-benefit and/or life cycle cost analyses—are not recommended for this project. The constructed PCPS test section was relatively short (0.15 miles) in comparison with typical paving projects, and the cost of the PCPS portion was only 2.7 percent of the total construction costs for the project. The use of PCPS on shorter roadway sections, such as one on this project, is more likely to have a relatively higher mobilization costs and may not reflect typical production rates. Hence, the cost analyses are expected to provide results that skew toward higher costs and lower productivity that are not representative of typical paving projects.

Furthermore, the purpose of constructing the experimental section of this project is to technically demonstrate the feasibility of PCPS technology in Florida. Using this project, FDOT intended to develop innovations, plans, specifications, and guidelines for PCPS-related areas including precast panel design, manufacturing, assembling criteria, post-placement grouting, post-tensioning systems, and post-construction pavement grinding for smoothness. From this perspective, FDOT has successfully demonstrated the construction of PCPS technology. The experience gained on this successful project will help FDOT implement these innovations more routinely on future projects.

¹ Rao, C., P. Littleton, S. Sadasivam, and G. Ullman, California Demonstration Project: Pavement Replacement Using a Precast Pavement System on I-15 in Ontario, Draft Report, Federal Highway Administration, Washington, DC., 2012. http://www.fhwa.dot.gov/hfl/summary/pdfs/ca_102012.pdf

² Rao, C., S. Sadasivam, P. Littleton, and J. Mallela, Virginia I-66 Concrete Pavement Replacement Using Precast Concrete Pavement Systems, Draft Report, Federal Highway Administration, Washington, DC., 2012. http://www.fhwa.dot.gov/hfl/summary/va_i66.pdf

³ FDOT Annual Statewide Averages (January 2011 - December 31, 2011), Historical Cost and Other Information, Florida Department of Transportation website. <http://www.dot.state.fl.us/specificationsoffice/estimates/historicalcostinformation/AnnualSWAve/AnnualStatewideAverage11.pdf>

APPENDIX

Florida DOT US-92 Showcase

Precast Concrete Pavement Systems

January 10, 2012

AGENDA

Moderator: Roger Schmitt, P.E., Materials and Research Engineer – FDOT District 5

7:30am	Registration/Check-in
8:00am - 8:15am	Introduction and Opening Remarks Alan E. Hyman, P.E., Director of Transportation Operations – FDOT District 5
8:15am - 8:30am	Highways for LIFE Overview David Hawk, P.E., Chief Operating Officer – FHWA - Florida Division
8:30am - 8:50am	National Perspective on Precast Concrete Pavement Systems Suneel Vanikar, P.E., Concrete Pavement Team Leader – Federal Highway Administration Sam Tyson, P.E., Concrete Pavement Engineer – Federal Highway Administration
8:50am - 9:45am	Project Design Overview Mario Bizzio, P.E., Technical Support & In-House Design Engineer – FDOT District 5 Sam Fallaha, P.E., Assistant State Structures Design Engineer – FDOT
9:45am - 10:00am	Break
10:00am - 11:00am	Project Construction Overview Jeremy Wolcott, P.E., Materials Operations Engineer – FDOT District 5 Jeremy Andrews, P.E., Project Manager – Superior Construction Company
11:00am - 11:30am	PCPS Lessons Learned from HfL Demonstration Projects Chetana Rao, Ph.D., Principal Research Engineer – Applied Research Associates, Inc.
11:30am - 12:30pm	Lunch
12:30pm	Load Vans
12:45pm	Vans Depart for Site Visit
1:00pm - 3:00pm	Site Visit
3:00pm	Vans Return to Kepler Road Complex
3:30pm - 4:00pm	Wrap-up Session (Open Panel Q&A)



Figure 20. FDOT showcase agenda.

ACKNOWLEDGMENTS

The project team would like to acknowledge the invaluable insights and guidance of FHWA Highways for LIFE Team Leader Byron Lord and Program Coordinators Mary Huie and Kathleen Bergeron, who served as the technical panel on this demonstration project. Their vast knowledge and experience with the various aspects of construction, technology deployment, and technology transfer helped immensely in developing both the approach and the technical matter for this document. The team is also indebted to FDOT Engineer Roger Schmitt, FDOT Structural Design Engineer Sam Fallaha, FDOT Pavement Design Engineer Mario Bizzio, AVCON, Inc. Engineer Brian Flynn, FDOT Project Manager Dennisse Zornan, and FHWA Florida Division Engineer Rafiq Darji for providing technical assistance during this project. Thanks to Terry Philips of Daytona Construction for providing contract documents and construction progress updates.